

(19) World Intellectual Property Organization
International Bureau



(43) International Publication Date
15 January 2009 (15.01.2009)

PCT

(10) International Publication Number
WO 2009/007778 A1

(51) International Patent Classification:
H04B 7/00 (2006.01)

(74) Agent: BRUNACCI, Marco; APTA SRL, Via Giardini,
625, I-41100 Modena (IT).

(21) International Application Number:
PCT/IB2007/003420

(81) Designated States (unless otherwise indicated, for every
kind of national protection available): AE, AG, AL, AM,
AT, AU, AZ, BA, BB, BG, BH, BR, BW, BY, BZ, CA, CH,
CN, CO, CR, CU, CZ, DE, DK, DM, DO, DZ, EC, EE, EG,
ES, FI, GB, GD, GE, GH, GM, GT, HN, HR, HU, ID, IL,
IN, IS, JP, KE, KG, KM, KN, KP, KR, KZ, LA, LC, LK,
LR, LS, LT, LU, LY, MA, MD, ME, MG, MK, MN, MW,
MX, MY, MZ, NA, NG, NI, NO, NZ, OM, PG, PH, PL,
PT, RO, RS, RU, SC, SD, SE, SG, SK, SL, SM, SV, SY,
TJ, TM, TN, TR, TT, TZ, UA, UG, US, UZ, VC, VN, ZA,
ZM, ZW.

(22) International Filing Date:
9 November 2007 (09.11.2007)

(25) Filing Language: Italian

(26) Publication Language: English

(30) Priority Data:
MO2007A000227 6 July 2007 (06.07.2007) IT

(84) Designated States (unless otherwise indicated, for every
kind of regional protection available): ARIPO (BW, GH,
GM, KE, LS, MW, MZ, NA, SD, SL, SZ, TZ, UG, ZM,
ZW), Eurasian (AM, AZ, BY, KG, KZ, MD, RU, TJ, TM),
European (AT, BE, BG, CH, CY, CZ, DE, DK, EE, ES, FI,
FR, GB, GR, HU, IE, IS, IT, LT, LU, LV, MC, MT, NL, PL,
PT, RO, SE, SI, SK, TR), OAPI (BF, BJ, CF, CG, CI, CM,
GA, GN, GQ, GW, ML, MR, NE, SN, TD, TG).

(71) Applicant (for all designated States except US): **TEKO
TELECOM S.P.A.** [IT/IT]; Via dell'Industria, 5, I-40068
San Lazzaro di Savena (IT).

(72) Inventor; and

(75) Inventor/Applicant (for US only): **NOTARGIACOMO,
Massimo** [IT/IT]; Via Berlinguer, 3/b/8, I-48020 S. Agata
Sul Santerno (RA) (IT).

Published:
— with international search report

(54) Title: APPARATUS AND METHOD FOR THE RADIO COVERAGE OF A VEHICLE, USABLE IN PARTICULAR IN
THE FIELD OF RAILWAY TRANSPORT OR THE LIKE

Fig. 1

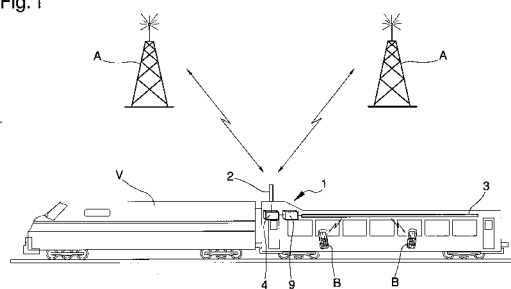

(57) Abstract: The apparatus for the radio coverage of a vehicle, usable in particular in the field of railway transport or the like, comprising first means of communication installable on a vehicle and suitable for the radio reception/transmission of a first signal at input and of a first signal at output from/to at least one remote base radio station, second means of communication installable on the vehicle and suitable for the radio reception/transmission of a second signal at input and of a second signal at output from/to an appliance positioned inside the vehicle, and a repeater device positioned in between the first and second means of communication and having an amplification unit in reception suitable for receiving the first signal at input and for generating the second signal at output and an amplification unit in transmission suitable for receiving the second signal at input and generating the first signal at output, and adjustment means for adjusting the power of the first signal at output from the first means of communication starting with the power measurement of the first signal at input.



WO 2009/007778 A1

APPARATUS AND METHOD FOR THE RADIO COVERAGE OF A VEHICLE, USABLE IN PARTICULAR IN THE FIELD OF RAILWAY TRANSPORT OR THE LIKE

Technical Field

5 The present invention relates to an apparatus and to a relative method for the radio coverage of a vehicle, both usable in particular in the field of railway transport or, in any case, in all those solutions in which the use of means of mass public transport is to be considered such as, for example, motor coaches, aeroplanes or boats/ships.

10 Background art

With particular reference to the railway transport sector, the need is known to overcome the limited radio connection between external base radio stations positioned along the area, so-called BTS (Base Transceiver Station), and appliances positioned inside coaches such as, for example, the cellular phones
15 of the passengers.

More specifically, the electrical conduction materials normally used to make the structure and the roofs of the coaches make it difficult or, in the worst cases, impossible, to establish a connection between the base radio stations and the appliances inside the coach.

20 To overcome this drawback, the use is currently known of appliances that can be installed on board the train and suitable for allowing the connection between the inside and the outside of the coach.

Such apparatus generally comprise one or more repeater devices with respective antennas that can be installed outside the coach and suitable for allowing a two-
25 directional radio communication with the base radio stations.

Each of these repeater devices is associated with transmission and receiver means positioned inside the vehicle and suitable for allowing a two-directional radio communication with appliances such as cellular phones or the like.

The transmission and receiver means can be made up, for example, of a fissured
30 cable installed along the coach or, alternatively, of one or more generally wide-band antennas.

The apparatus can also be equipped with a two-directional amplifier connected

in cascade to the repeater device, especially in the case of the use of the fissured cable or, also in the case of having to recover the losses introduced by the passive distribution system.

Though permitting the overcoming of problems deriving from the shielding effect and, in general, from the attenuation caused by the vehicle itself, the above-described known apparatus does however have a number of drawbacks.

The problems mainly relate to the interaction of the apparatus with the existing mobile-radio network and, in particular, the possible de-sensitization of the base radio station whenever the train transits "too close".

10 In fact, in the case of the transmission of a radio signal from the antenna installed on the train to a nearby base radio station, the latter receives both the noise irradiated by the repeater device and the spurious emissions produced by the inter-modulation.

Consequently, if the distance between the antenna and the base radio station is below a certain minimum, the transmitted noise and the spurious emissions produced by the inter-modulation are of such intensity as to result in the de-sensitization of the base radio station.

The known apparatus is also subject to the so-called "near-far problem", which can occur during train movement if the antenna connected to the repeater device interacts with at least two distinct base radio stations that transmit and receive information at the same time.

In particular, in the event of the antenna being positioned near a first base radio station and far from a second base radio station, the signal received from the first station could disturb the signal received from the second station to the extent of making this not understandable.

Object of the Invention

The main aim of the present invention is to provide an apparatus and a relative method for the radio coverage of a vehicle, usable in particular in the field of railway transport or the like, which allows to solve the above mentioned problems of interaction with the base radio stations.

Another object of the present invention is to provide an apparatus and a method for the radio coverage of a vehicle usable for radio communication through

different service providers and by means of different communication standards. Another object of the present invention is to provide an apparatus and a method for the radio coverage of a vehicle that allow to overcome the mentioned drawbacks of the prior art within the ambit of a simple and rational solution which is easy and effective to use as well as having a fairly low cost.

5 The above objects are all achieved by this apparatus for the radio coverage of a vehicle, usable in particular in the field of railway transport or the like, comprising first means of communication installable on a vehicle and suitable for the radio reception/transmission of a first signal at input and of a first signal at output from/to at least one remote base radio station, second means of communication installable on said vehicle and suitable for the radio reception/transmission of a second signal at input and of a second signal at output from/to at least one appliance positioned inside said vehicle, and at least one repeater device positioned in between said first and said second means of communication and having at least one amplification unit in reception suitable for receiving said first signal at input and for generating said second signal at output and at least one amplification unit in transmission suitable for receiving said second signal at input and generating said first signal at output, characterized in that said repeater device comprises adjustment means for adjusting the power of the first signal at output from said first means of communication starting with the power measurement of said first signal at input.

The above objects are further achieved by a method for the radio coverage of a vehicle, usable in particular in the field of railway transport or the like, comprising: a first reception phase of a first signal at input from at least a first remote base radio station by means of first means of communication installed on a vehicle; a first amplification phase of said first signal at input to obtain a second signal at output; a first transmission phase of said second signal at output to at least an apparatus located inside said vehicle by means of second means of communication; a second reception phase of a second signal at input coming from said apparatus by means of said second means of communication; a second amplification phase of said second signal at input to obtain a first signal

at output; a second transmission phase of said first signal at output to said remote base radio station by means of said first means of communication, characterized in that it comprises at least one adjustment phase of the power of the first signal at output from said first means of communication starting with
5 the power measurement of said first signal at input.

Brief Description of the Drawings

Further characteristics and advantages will appear more evident from the description of a preferred but not exclusive embodiment of an apparatus and a method for the radio coverage of a vehicle, usable in particular in the field of
10 railway transport and illustrated indicatively by way of non limiting example, in the attached drawings wherein:

figure 1 is a diagram that shows in a general way the application of the apparatus according to the invention in the field of railway transport;

figure 2 is a general functional diagram of the apparatus according to the
15 invention.

Embodiments of the Invention

With special reference to such figures, by 1 is globally indicated an apparatus for the radio coverage of a vehicle V.

A particular, but not exclusive solution, illustrated in figure 1, considers the use
20 of the apparatus 1 in the field of railway transport, for the purpose of ensuring the radio coverage inside the coaches of a train. The use of the apparatus 1 for different types of means of mass public transport cannot however be ruled out such as, for example, motor coaches, aeroplanes or boats/ships.

The apparatus 1 comprises first means of communication 2, made up of an
25 antenna installable on the vehicle V and suitable for the radio reception/transmission of a first signal at input S_{11} and of a first signal at output S_{O1} from/to one or more remote base radio stations, indicated in figure 1 by the reference A.

The apparatus 1 also comprises second means of communication 3, made up of
30 a fissured cable installable inside the vehicle V and suitable for the radio reception/transmission of a second signal at input S_{12} and of a second signal at output S_{O2} from/to at least one appliance B located inside the vehicle itself.

Usefully, the fissured cable 3 installed inside the vehicle V is optimised according to its length and to the band in which it operates and permits obtaining a uniform coverage along the entire train coach.

Alternatively, the second means of transmission 3 can be realised by means of a
5 wide-band antenna installed inside the vehicle V.

The appliances B inside the vehicle V can be of different type and use and can be composed, for example, of cellular phones, palm top computers or the like used by the vehicle users and operating according to different technical systems and/or with different providers.

10 Usefully, the appliances B can be made up of communication devices suitable for permitting specific radio links with the police or emergency services or, again, of automatic driving and safety control devices of the vehicle V operating according to dedicated communication standards (such as the GSMR standard in the railway field).

15 A repeater device 4 of the apparatus 1 is placed in between the antenna 2 and the fissured cable 3 and has a first amplification line 5 of the first signal at input S_{I1} from the antenna 2 and a second amplification line 6 of the second signal at input S_{I2} from the fissured cable 3.

In particular, the first amplification line 5 has an amplification unit in reception,
20 generically indicated in figure 2 by the reference 7, suitable for receiving the above first signal at input S_{I1} from the antenna 2 and for generating the second signal at output S_{O2} , subsequently transmitted by the fissured cable 3 inside the vehicle V.

Similarly, the second amplification line 6 has an amplification unit in
25 transmission, generically indicated in figure 2 by the reference 8, suitable for receiving the above second signal at input S_{I2} from the fissured cable 3 and for generating the first signal at output S_{O1} , subsequently transmitted by the antenna 2 to the base radio station A.

Advantageously, the apparatus 1 is configured in such a way to allow the
30 correct transmission and reception of the signals even in the case of communication between the antenna 2 and more than one base radio station A, so as to minimise the effects of the so-called "near-far problem".

In particular, the amplification units in reception and in transmission 7 and 8 can be made in different ways, depending on the services, the providers, the bands used and the specific technical characteristics required.

Usefully, the amplification unit in transmission 8 is sized so as to maintain the
5 spurious emissions produced by inter-modulation and subsequently transmitted by the antenna 2 below a predetermined threshold (for example -56dBm). This permits limiting the possibilities of desensitization of a base radio station A located near the antenna 2.

In particular, the max power deliverable by the amplification unit in
10 transmission 8 is oversized with respect to the rated operating power so as to ensure the linearity of the amplification on the entire transmission band.

The low gain also permits maintaining off-band amplification within regulatory limits and avoiding disturbances to communication in adjoining bands or of other services or providers.

15 With particular reference to the realisation of the second means of communication 3 by means of a fissured cable, the apparatus 1 can comprise a supplementary amplifier device 9 linked in cascade to the repeater device 4.

The repeater device 4 comprises a first connection port 10 associated with the antenna 2 and connected to the input of the amplification unit in reception 7 and
20 to the output of the amplification unit in transmission 8.

The first connection port 10 has a duplexer or the like suitable for allowing the transmission of the first signal at output S_{O1} and the reception of the first signal at input S_{I1} by means of the antenna 2 only. Different solutions cannot however be ruled out.

25 Similarly, the repeater device 4 comprises a second connection port 11 associated with the fissured cable 3 by interposition of the supplementary amplifier device 9 and connected to the output of the amplification unit in reception 7 and to the input of the amplification unit in transmission 8.

The second connection port 11 also has a duplexer or the like suitable for
30 allowing the transmission of the second signal at output S_{O1} and the reception of the second signal at input S_{I1} by means of just one fissured cable 3. Different solutions cannot however be ruled out.

Advantageously, the repeater device 4 comprises adjustment means, indicated generically in figure 2 by the reference 12, suitable for adjusting the power of the first signal at output S_{O1} from the antenna 2 starting with the power value of the first signal at input S_{I1} coming from the base radio station A.

5 This allows the adjustment of the power of the first signal at output S_{O1} depending on the relative distance between the antenna 2 and the base radio station A.

In particular, the adjustment means 12 comprise a detection unit 13 for detecting the power measurement of the first signal at input S_{I1} , of the type of an RMS
10 detector or the like, associated with the first amplification line 5.

The adjustment means 12 also comprise a calculation unit 14, of the type of a microprocessor or the like, which is suitable for processing the detected power measurement and which is operatively associated with the detection unit 13 and with the amplification unit in transmission 8.

15 In particular, the calculation unit 14 comprises means of determination 15 of the section attenuation value between the antenna 2 and the base radio station A, determined starting with the power measurement of the first signal at input S_{I1} read by the detection unit 13.

The calculation unit 14 also has first means of definition 16 of the optimal
20 power gain of the amplification unit in transmission 8, defined starting with the above determined section attenuation value.

In particular, by "optimal power gain" is meant that gain value of the amplification unit in transmission 8 which, compared with the determined section attenuation, allows minimising the noise irradiated by the repeater
25 device 4 and received by the base radio station A with the first signal at output S_{O1} .

More specifically, starting with a predetermined reference value of the section attenuation, for example 70dB, the gain of the amplification unit in transmission 8 can be reduced by 1dB for every 1dB drop, below the 70dB in the section
30 attenuation value determined by the calculation unit 14.

This permits dynamically changing the gain of the first signal at output S_{O1} when the relative distance changes between the antenna 2 and the base radio

station A and, in particular, permits automatically reducing the gain of the first signal at output S_{O1} when the relative distance is reduced between the antenna 2 and the base radio station A, so as to minimise the noise irradiated by the repeater device 4.

5 Advantageously, the calculation unit 14 has second means of definition 17 of a maximum power threshold value of the first signal at output S_{O1} starting with the determined section attenuation.

In particular, by "maximum threshold value" is meant that power value of the first signal at output S_{O1} which, if not exceeded, permits minimising the
10 spurious emissions produced by the inter-modulation of the repeater device 4 and transmitted to the base radio station A.

More specifically, starting with a predetermined reference value of the section attenuation, for example 70dB, such maximum threshold value can be reduced by 1dB for every 1dB drop below the 70dB in the section attenuation value
15 determined by the calculation unit 14.

This way, the inter-modulation spurious emissions are reduced from 1dB to 5dB depending on the type of amplifier used and in relation to the order of the inter-modulation spurious emissions.

The power of the first signal at output S_{O1} can be detected and maintained below
20 the above maximum threshold value by means of an ALC (Automatic Level Control) unit of the commonly used type, shown in figure 2 by the reference 18 and operatively associated with the amplification unit in transmission 8.

The method according to the invention considers the reception by means of the antenna 2 of the first signal at input S_{I1} from at least one remote base radio
25 station A, the subsequent amplification by means of the amplification unit in reception 7 of the first signal at input S_{I1} to obtain the second signal at output S_{O2} and, finally, the transmission of the second signal at output S_{O2} by means of the fissured cable 3 installed inside the vehicle V.

At the same time, the method considers the reception by means of the fissured
30 cable 3 of the second signal at input S_{I2} coming from at least one appliance B located inside the vehicle V, the subsequent amplification by means of the amplification unit in transmission 8 of the second signal at input S_{I2} to obtain

the first signal at output S_{O1} and, finally, the transmission of the first signal at output S_{O1} by means of the antenna 2 to at least one remote base radio station A. Advantageously, the method comprises the dynamic and automatic adjustment of the power of the first signal at output S_{O1} , by means of the adjustment means 5 12 and starting with the power measurement of the first signal at input S_{I1} .

In particular, the above adjustment phase comprises reading the power measurement of the first signal at input S_{I1} by means of the detection means 13 and the determination of the section attenuation value between the antenna 2 and the base radio station A, by means of the means of determination 15 of the 10 calculation unit 12, and starting with the determined power measurement.

The adjustment phase also comprises a first definition phase of the optimal power gain of the amplification unit in transmission 8, performed by means of the first definition means 16 of the calculation unit 12, and starting with the determined section attenuation value.

15 Usefully, the adjustment phase comprises a further second definition phase of the maximum power threshold value of the first signal at output S_{O1} , by means of the second means of definition 17 of the calculation unit 12, and starting with the determined section attenuation value.

Advantageously, the supplementary amplifier device 9 performs a first 20 supplementary amplification phase of the second signal at output S_{O2} before the transmission inside the vehicle V by means of the fissured cable 3.

Similarly, the supplementary amplifier device 9 performs a second supplementary amplification phase of the second signal at input S_{I2} following the reception by means of the fissured cable 3.

25 It has in point of fact been found how the described invention achieves the proposed objects, and in particular the fact is underlined that the dynamic adjustment of the gain and the power of the first signal at output from the antenna on the basis of the power of the first signal at input permits overcoming the known problems of interaction with a base radio station located near the 30 antenna.

The suitable sizing of the described apparatus also permits operating correctly in the case of communications with two or more base radio stations, minimising

the effects of the so-called “near-far problem”.

The apparatus and the method described above further allow implementing radio communications through different service providers and using different communication standards, thus permitting the use of the major standards used
5 by the telephone operators such as, for example, GSM, R-GSM, DCS, UMTS, AMPS, PCS, DVB-H and others.

The invention thus conceived is susceptible to numerous modifications and variations, all of which falling within the scope of the inventive concept.

Furthermore all the details can be replaced with others that are technically
10 equivalent.

In practice, the materials used, as well as the contingent shapes and dimensions, may be any according to requirements without because of this moving outside the protection scope of the following claims.

CLAIMS

- 1) Apparatus for the radio coverage of a vehicle, usable in particular in the field of railway transport or the like, comprising first means of communication installable on a vehicle and suitable for the radio reception/transmission of a first signal at input and of a first signal at output from/to at least one remote
5 base radio station, second means of communication installable on said vehicle and suitable for the radio reception/transmission of a second signal at input and of a second signal at output from/to at least one appliance positioned inside said vehicle, and at least one repeater device positioned in between said first and said
10 second means of communication and having at least one amplification unit in reception suitable for receiving said first signal at input and for generating said second signal at output and at least one amplification unit in transmission suitable for receiving said second signal at input and generating said first signal at output, characterized in that said repeater device comprises adjustment means
15 for adjusting the power of the first signal at output from said first means of communication starting with the power measurement of said first signal at input.
- 2) Apparatus according to claim 1, characterized in that said adjustment means comprise at least one detection unit for detecting said power measurement of the
20 first signal at input.
- 3) Apparatus according to one or more of the preceding claims, characterized in that said adjustment means comprise means of determination of the section attenuation value between said first means of communication and said base radio station starting with said power measurement of the first signal at input.
- 25 4) Apparatus according to one or more of the preceding claims, characterized in that said adjustment means comprise first means of definition of the optimal power gain of said amplification unit in transmission, defined starting with said determined section attenuation value.
- 5) Apparatus according to one or more of the preceding claims, characterized
30 in that said adjustment means comprise second means of definition of a maximum power threshold value of said signal at output starting with the determined section attenuation.

- 6) Apparatus according to one or more of the preceding claims, characterized in that said adjustment means comprise a calculation unit having at least one selected from said means of determination, said first means of definition and said second means of definition.
- 5 7) Apparatus according to one or more of the preceding claims, characterized in that said calculation unit is operatively associated with said amplification unit in transmission.
- 8) Apparatus according to one or more of the preceding claims, characterized in that said calculation unit comprises at least one microprocessor or the like.
- 10 9) Apparatus according to one or more of the preceding claims, characterized in that said detection unit is operatively associated with said calculation unit.
- 10) Apparatus according to one or more of the preceding claims, characterized in that said detection unit comprises at least a RMS detector or the like.
- 11) Apparatus according to one or more of the preceding claims, characterized
15 in that the gain, power and linearity of said amplification unit in transmission are sized so as to maintain the spurious emissions produced by inter-modulation below a predetermined threshold.
- 12) Apparatus according to one or more of the preceding claims, characterized in that said repeater device comprises at least one first connection port
20 associable with said first means of communication and connected to said amplification units in reception and in transmission.
- 13) Apparatus according to one or more of the preceding claims, characterized in that said repeater device comprises at least a second connection port associable with said second means of communication and connected to said
25 amplification units in reception and in transmission.
- 14) Apparatus according to one or more of the preceding claims, characterized in that at least one between said first and second connection port comprises a duplexer or the like.
- 15) Apparatus according to one or more of the preceding claims, characterized
30 in that it comprises at least one supplementary amplifier device placed in between said repeater device and said second means of communication.
- 16) Apparatus according to one or more of the preceding claims, characterized

in that said first means of communication comprise at least one antenna or the like.

17) Apparatus according to one or more of the preceding claims, characterized in that said second means of communication comprise at least one between an
5 antenna, a fissured cable or the like.

18) Method for the radio coverage of a vehicle, usable in particular in the field of railway transport or the like, comprising:

- 10 - a first reception phase of a first signal at input from at least a first remote base radio station by means of first means of communication installed on a vehicle;
 - a first amplification phase of said first signal at input to obtain a second signal at output;
 - a first transmission phase of said second signal at output to at least an apparatus located inside said vehicle by means of second means of
15 communication;
 - a second reception phase of a second signal at input coming from said apparatus by means of said second means of communication;
 - a second amplification phase of said second signal at input to obtain a first signal at output;
 - 20 - a second transmission phase of said first signal at output to said remote base radio station by means of said first means of communication;
- characterized in that it comprises at least one adjustment phase of the power of the first signal at output from said first means of communication starting with the power measurement of said first signal at input.

25 19) Method according to claim 18, characterized in that said adjustment phase comprises reading said power measurement of the first signal at input.

20) Method according to one or more of the claims 18 and 19, characterized in that said adjustment phase comprises the determination of the section attenuation value between said first means of communication and said base
30 radio station, starting with the power measurement of said first signal at input.

21) Method according to one or more of the claims 18 to 20, characterized in that said adjustment phase comprises a first definition phase of the optimal

power gain during said second amplification phase starting with said determined section attenuation value.

22) Method according to one or more of the claims 18 to 21, characterized in that said adjustment phase comprises a second definition phase of a maximum
5 power threshold value of said first signal at output starting with said determined section attenuation value.

23) Method according to one or more of the claims 18 to 22, characterized in that it comprises a first supplementary amplification phase before said first transmission phase.

10 24) Method according to one or more of the claims 18 to 23, characterized in that it comprises a second supplementary amplification phase following said second reception phase.

Fig. 1

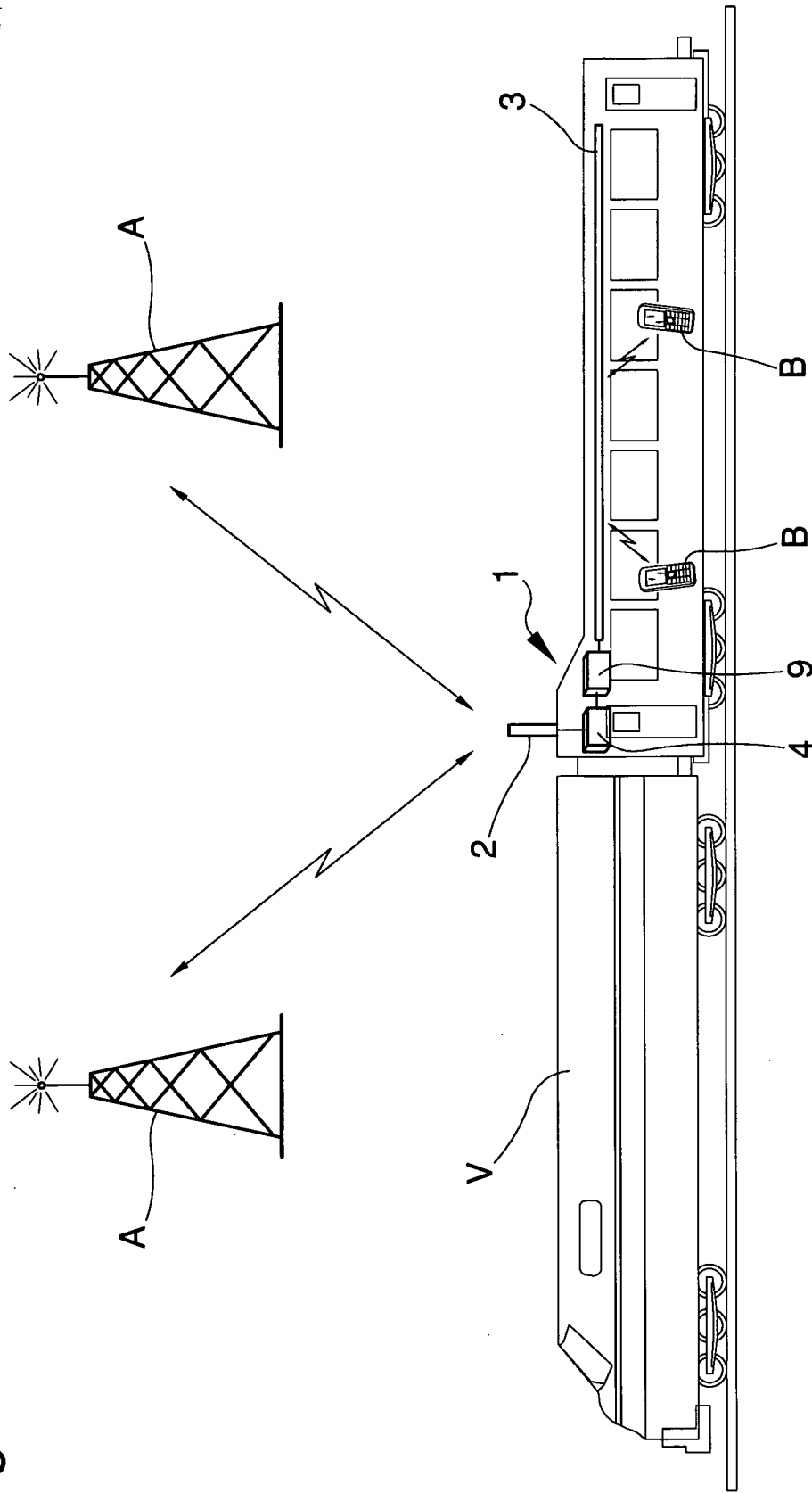

2 / 2

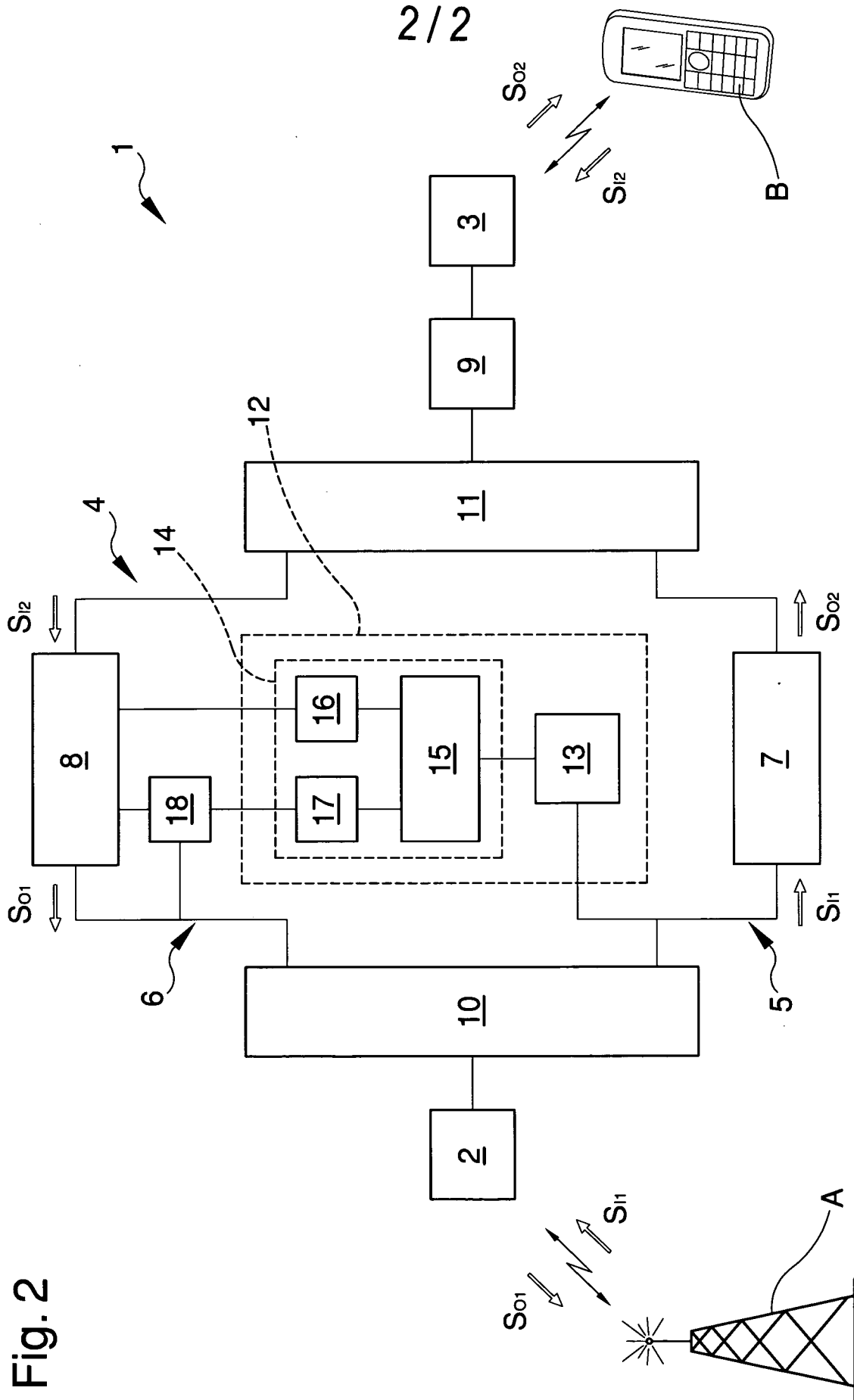

Fig. 2

INTERNATIONAL SEARCH REPORT

International application No
PCT/IB2007/003420

A. CLASSIFICATION OF SUBJECT MATTER INV. H04B7/00				
According to International Patent Classification (IPC) or to both national classification and IPC				
B. FIELDS SEARCHED				
Minimum documentation searched (classification system followed by classification symbols) H04Q H04B				
Documentation searched other than minimum documentation to the extent that such documents are included in the fields searched				
Electronic data base consulted during the international search (name of data base and, where practical, search terms used) EPO-Internal, WPI Data				
C. DOCUMENTS CONSIDERED TO BE RELEVANT				
Category*	Citation of document, with indication, where appropriate, of the relevant passages	Relevant to claim No.		
X	WO 2005/048487 A (GS TELETECH CO LTD [KR]; LEE GI YOUNG [KR]; KWOUN CHUL [KR]) 26 May 2005 (2005-05-26) abstract page 1, line 20 - page 2, line 8 page 3, line 15 - page 4, line 14 page 13, lines 10-15 page 16, lines 6-11	1-22		
A	GB 2 426 665 A (SAMSUNG ELECTRONICS CO LTD [GB]) 29 November 2006 (2006-11-29) abstract page 6, line 11 - page 9, line 17 page 16, lines 15-19 ----- -/--	1-24		
<input checked="" type="checkbox"/> Further documents are listed in the continuation of Box C.				
<input checked="" type="checkbox"/> See patent family annex.				
* Special categories of cited documents :				
<table style="width: 100%; border: none;"> <tr> <td style="width: 50%; border: none; vertical-align: top;"> *A* document defining the general state of the art which is not considered to be of particular relevance *E* earlier document but published on or after the international filing date *L* document which may throw doubts on priority claim(s) or which is cited to establish the publication date of another citation or other special reason (as specified) *O* document referring to an oral disclosure, use, exhibition or other means *P* document published prior to the international filing date but later than the priority date claimed </td> <td style="width: 50%; border: none; vertical-align: top;"> *T* later document published after the international filing date or priority date and not in conflict with the application but cited to understand the principle or theory underlying the invention *X* document of particular relevance; the claimed invention cannot be considered novel or cannot be considered to involve an inventive step when the document is taken alone *Y* document of particular relevance; the claimed invention cannot be considered to involve an inventive step when the document is combined with one or more other such documents, such combination being obvious to a person skilled in the art. *&* document member of the same patent family </td> </tr> </table>			*A* document defining the general state of the art which is not considered to be of particular relevance *E* earlier document but published on or after the international filing date *L* document which may throw doubts on priority claim(s) or which is cited to establish the publication date of another citation or other special reason (as specified) *O* document referring to an oral disclosure, use, exhibition or other means *P* document published prior to the international filing date but later than the priority date claimed	*T* later document published after the international filing date or priority date and not in conflict with the application but cited to understand the principle or theory underlying the invention *X* document of particular relevance; the claimed invention cannot be considered novel or cannot be considered to involve an inventive step when the document is taken alone *Y* document of particular relevance; the claimed invention cannot be considered to involve an inventive step when the document is combined with one or more other such documents, such combination being obvious to a person skilled in the art. *&* document member of the same patent family
A document defining the general state of the art which is not considered to be of particular relevance *E* earlier document but published on or after the international filing date *L* document which may throw doubts on priority claim(s) or which is cited to establish the publication date of another citation or other special reason (as specified) *O* document referring to an oral disclosure, use, exhibition or other means *P* document published prior to the international filing date but later than the priority date claimed	*T* later document published after the international filing date or priority date and not in conflict with the application but cited to understand the principle or theory underlying the invention *X* document of particular relevance; the claimed invention cannot be considered novel or cannot be considered to involve an inventive step when the document is taken alone *Y* document of particular relevance; the claimed invention cannot be considered to involve an inventive step when the document is combined with one or more other such documents, such combination being obvious to a person skilled in the art. *&* document member of the same patent family			
Date of the actual completion of the international search <div style="text-align: center; font-weight: bold;">24 June 2008</div>		Date of mailing of the international search report <div style="text-align: center; font-weight: bold;">03/07/2008</div>		
Name and mailing address of the ISA/ European Patent Office, P.B. 5818 Patentlaan 2 NL - 2280 HV Rijswijk Tel. (+31-70) 340-2040, Tx. 31 651 epo nl, Fax: (+31-70) 340-3016		Authorized officer <div style="text-align: center; font-weight: bold;">Falò, Luca</div>		

INTERNATIONAL SEARCH REPORT

International application No
PCT/IB2007/003420

C(Continuation). DOCUMENTS CONSIDERED TO BE RELEVANT		
Category*	Citation of document, with indication, where appropriate, of the relevant passages	Relevant to claim No.
A	EP 1 282 327 A (HUTCHISON WHAMPOA ENTPR LTD [VG]) 5 February 2003 (2003-02-05) abstract paragraphs [0004] - [0015], [0023], [0024]; claim 1 -----	1-24
A	EP 1 482 751 A (KYOCERA CORP [JP]) 1 December 2004 (2004-12-01) abstract paragraphs [0034], [0035], [0073], [0074] - paragraphs [0251] - [0255]; figure 31 -----	1-24

INTERNATIONAL SEARCH REPORT

Information on patent family members

International application No

PCT/IB2007/003420

Patent document cited in search report	Publication date	Patent family member(s)	Publication date
WO 2005048487	A	26-05-2005	EP 1690347 A1 16-08-2006
			US 2005107034 A1 19-05-2005
GB 2426665	A	29-11-2006	NONE
EP 1282327	A	05-02-2003	AT 367723 T 15-08-2007
			DE 60221200 T2 10-04-2008
			GB 2380355 A 02-04-2003
			HK 1051094 A1 12-12-2003
			JP 2003115791 A 18-04-2003
			KR 20030011630 A 11-02-2003
			NZ 520527 A 27-02-2004
			TW 522674 B 01-03-2003
EP 1482751	A	01-12-2004	CN 1574700 A 02-02-2005
			KR 20040103321 A 08-12-2004
			KR 20060096188 A 08-09-2006
			KR 20060093311 A 24-08-2006
			US 2004259545 A1 23-12-2004
			US 2008043692 A1 21-02-2008