

(19) World Intellectual Property Organization  
International Bureau



(43) International Publication Date  
13 November 2008 (13.11.2008)

PCT

(10) International Publication Number  
**WO 2008/137637 A2**

(51) International Patent Classification:  
*G01J 3/26* (2006.01) *G01N 21/63* (2006.01)  
*G01J 3/44* (2006.01)

(74) Agents: ABELEV, Gary et al.; Dorsey & Whitney Llp,  
250 Park Avenue, New York, NY 10177 (US).

(21) International Application Number:  
PCT/US2008/062354

(81) Designated States (*unless otherwise indicated, for every kind of national protection available*): AE, AG, AL, AM, AO, AT, AU, AZ, BA, BB, BG, BH, BR, BW, BY, BZ, CA, CH, CN, CO, CR, CU, CZ, DE, DK, DM, DO, DZ, EC, EE, EG, ES, FI, GB, GD, GE, GH, GM, GT, HN, HR, HU, ID, IL, IN, IS, JP, KE, KG, KM, KN, KP, KR, KZ, LA, LC, LK, LR, LS, LT, LU, LY, MA, MD, ME, MG, MK, MN, MW, MX, MY, MZ, NA, NG, NI, NO, NZ, OM, PG, PH, PL, PT, RO, RS, RU, SC, SD, SE, SG, SK, SL, SM, SV, SY, TJ, TM, TN, TR, TT, TZ, UA, UG, US, UZ, VC, VN, ZA, ZM, ZW.

(22) International Filing Date: 2 May 2008 (02.05.2008)

(25) Filing Language: English

(26) Publication Language: English

(30) Priority Data:  
60/915,990 4 May 2007 (04.05.2007) US

(84) Designated States (*unless otherwise indicated, for every kind of regional protection available*): ARIPO (BW, GH, GM, KE, LS, MW, MZ, NA, SD, SL, SZ, TZ, UG, ZM, ZW), Eurasian (AM, AZ, BY, KG, KZ, MD, RU, TJ, TM), European (AT, BE, BG, CH, CY, CZ, DE, DK, EE, ES, FI, FR, GB, GR, HR, HU, IE, IS, IT, LT, LU, LV, MC, MT, NL, NO, PL, PT, RO, SE, SI, SK, TR), OAPI (BF, BJ, CF, CG, CI, CM, GA, GN, GQ, GW, ML, MR, NE, SN, TD, TG).

(71) Applicant (*for all designated States except US*): THE GENERAL HOSPITAL CORPORATION [US/US]; 55 Fruit Street, Boston, MA 02114 (US).

(72) Inventors; and

(75) Inventors/Applicants (*for US only*): YUN, Seok-Hyun [KR/US]; 30 Cambridge Park Drive, Apt 4128, Cambridge, MA 02140 (US). SCARCELLI, Giuliano [IT/US]; 31 Sheafe Street, Apt. 2, Boston, MA 02113 (US).

Published:  
— *without international search report and to be republished upon receipt of that report*



WO 2008/137637 A2

(54) Title: METHODS, ARRANGEMENTS AND SYSTEMS FOR OBTAINING INFORMATION ASSOCIATED WITH A SAMPLE USING OPTICAL MICROSCOPY

(57) Abstract: Exemplary embodiments of methods, arrangements and systems for obtaining information about a sample can be provided. For example, in one exemplary embodiment, it is possible to receive a first electro-magnetic radiation from a sample which is based on a second electro-magnetic radiation forwarded to the sample. The first electro-magnetic radiation may have a first frequency and the second electro-magnetic radiation may have a second frequency which is different from the first frequency. The difference between the first and second frequencies can be based on an acoustic wave inside the sample related to at least one characteristic of the sample. Further, it is possible to receive at least a portion of the first electromagnetic radiation and separate it into a particular finite number (N) of frequency component radiations. In addition, it is possible to receive a particular energy of more than 1/N of energy of the third electro-magnetic radiation, and generate information associated with the sample. Certain exemplary embodiments of the present invention are capable of obtaining information associated with a sample, particularly its mechanical properties, non-contact using electromagnetic radiation.

**METHODS, ARRANGEMENTS AND SYSTEMS FOR OBTAINING INFORMATION  
ASSOCIATED WITH A SAMPLE USING OPTICAL MICROSCOPY**

CROSS-REFERENCE TO RELATED APPLICATION(S)

5 [0001] This application is based upon and claims the benefit of priority from U.S. Patent Application Serial No. 60/915,990, filed May 4, 2007, the entire disclosure of which is incorporated herein by reference.

FIELD OF THE INVENTION

10 [0002] The present invention relates to methods, arrangements and systems which can obtain acoustic information associated with a sample using electromagnetic radiation, and more particularly to such methods, systems and arrangements that can obtain viscoelastic properties of the sample by performing highly efficient Brillouin optical spectroscopy and imaging. This invention further relates to methods, arrangements and systems that combine Brillouin spectroscopy or imaging with reflectance, fluorescence, or Raman spectroscopy or imaging  
15 for simultaneous multimodal characterization of a sample.

BACKGROUND INFORMATION

[0003] When an electromagnetic radiation or an optical wave is propagated in a medium, it can be scattered inelastically by acoustic phonons inside the material. This process is known as Brillouin scattering. Brillouin scattering involves acoustic phonons, which may be  
20 different from Raman scattering that involves vibrational or rotational phonons.

[0004] Spontaneous Brillouin scattering involves acoustic phonons that may be present in a material by thermally-induced density fluctuations. Brillouin scattering can be further enhanced, stimulated, or forced by one or multiple optical pump waves with strong intensity. The magnitude and frequency of Brillouin-scattered light, or its optical spectrum, can be

determined by characteristics of the acoustic phonons inside the material. The latter may be closely related to mechanical properties of the medium, such as modulus and hypersonic damping coefficient. Such viscoelastic properties therefore may be measurable by examining the Brillouin scattered light. This technique is referred to as Brillouin spectroscopy. Various techniques to detect the Brillouin signal have been widely applied in physics, material science, and mechanical engineering.

[0005] Prior Brillouin scattering studies have been also performed on biological samples, such as collagen fibers, cornea, and crystalline lens, *ex vivo*, as described in J. M. Vaughan and J. T. Randall, "Brillouin-Scattering, Density and Elastic Properties of the Lens and Cornea of the Eye," *Nature*, vol. 284, pp. 489-491, 1980, R. Harley, D. James, A. Miller, and J. W. White, "Phonons and Elastic-Moduli of Collagen and Muscle," *Nature*, vol. 267, pp. 285-287, 1977, and J. Randall and J. M. Vaughan, "Brillouin-Scattering in Systems of Biological Significance," *Philosophical Transactions of the Royal Society of London Series A-Mathematical Physical and Engineering Sciences*, vol. 293, pp. 341-348, 1979. However, the potential of using Brillouin scattering for tissue biomechanics and tissue engineering has not been significantly explored, possibly because of long acquisition times required by the spectral analysis.

[0006] Accordingly, there is a need to overcome the deficiencies described herein above, and to provide improved apparatus, systems and processes for analyzing tissue biomechanics using Brillouin techniques.

#### **OBJECTS AND SUMMARY OF EXEMPLARY EMBODIMENTS**

[0007] To address and/or overcome the above-described problems and/or deficiencies, exemplary embodiments of imaging systems, arrangements and processes can be provided that are capable of combining a rapid spectroscopic analysis of Brillouin scattering with high

spatial-resolution microscopy to probe a sample such as human tissue or artificially engineered tissue or other natural and synthetic biomaterial and retrieve their biomechanical properties such as complex modulus at the tissue.

[0008] In one exemplary apparatus, a novel rapid yet high-resolution spectroscopic analysis  
5 can enable the image formation. A pump beam can be scanned over a sample through an objective lens, and Brillouin-shifted optical waves are detected to characterize their Brillouin spectra. The measured spectral features of the Brillouin signal can be used as contrast for imaging; an image can be obtained by use of a proper lookup table or an appropriate processing computational routine. Thin cross-sectional images of a biological sample can be  
10 obtained by using a high numerical-aperture objective lens and confocal detection.

[0009] In another exemplary apparatus in accordance with the present invention, the rapid spectral analysis can be multiplexed for different regimes. This can include empowering an optical microscope with different spectral modalities. Elastic scattering, Raman scattering, and/or fluorescence as well as Brillouin scattering from a sample can be simultaneously  
15 measured and three-dimensionally mapped to obtain a structural, chemical, functional as well as mechanical information of the sample.

[0010] Exemplary embodiments of the present invention provide apparatus and methods which can allow information about biomechanical properties of a material, particularly a biomaterial, to be obtained non-invasively. Such exemplary embodiments can find a wide  
20 range of applications in biology and medicine as well as tissue engineering. Potential applications of Brillouin microscopy include *in situ*, or *in vivo*, real-time characterization of collagen cross-linking, intraoperative characterizations of tissues based on biomechanical properties, *in vivo* disease diagnosis, intraoperative tumor margin determination, wound healing monitoring and/or tissue ablation monitoring.

[0011] For example, using the exemplary embodiments of the present invention, it is possible to obtain the viscoelastic properties of a sample such as biomaterial, by performing highly efficient Brillouin optical spectroscopy or imaging. Further exemplary embodiments of the present invention can further relate to methods, arrangements and systems that combine  
5 Brillouin spectroscopy and imaging with reflectance, fluorescence, or Raman spectroscopy and imaging for simultaneous multimodal characterization of a sample.

[0012] Thus, in accordance with certain exemplary embodiments of the present invention, arrangements and methods are provided for obtaining information about a sample. For example, in one exemplary embodiment, it is possible (e.g., using a first arrangement) to  
10 receive a first electro-magnetic radiation from a sample which is based on a second electro-magnetic radiation forwarded to the sample. The first electro-magnetic radiation can have a first frequency and the second electro-magnetic radiation has a second frequency which is different from the first frequency. The difference between the first and second frequencies can be based on an acoustic wave inside the sample related to at least one characteristic of the  
15 sample. For example, such difference can be is between about -100 GHz and +100 GHz and may be based on an acoustic wave inside the sample related to at least one characteristic of the sample. The first arrangement may employ a confocal pinhole or single-mode optical fiber.

[0013] Further exemplary embodiments of the present invention can facilitate (e.g., using a  
20 second arrangement) a receipt of at least a portion of the first electromagnetic radiation and separate such second electromagnetic radiation into a particular finite number (N) of frequency component radiations. For example, N can correspond to the number of spectrally resolvable elements and, typically, can range from about 10 to 100 for a Fabry-Perot interferometer or a diffractive grating. A plurality of such frequency component radiations can  
25 be simultaneously measured by an array of detectors, where the total combined energy of the

frequency component radiations may be greater than  $1/N$  times the energy of the received portion of the first electromagnetic radiation.

[0014] . In addition, according to the exemplary embodiment of the present invention, it is possible (e.g., using a third arrangement) to receive a particular energy of more than  $1/N$  of  
5 energy of the third electro-magnetic radiation, and generate information associated with the sample.

[0015] According to another exemplary embodiment of the present invention, it is possible (e.g., using a fourth arrangement) to generate information associated with the sample and to create images of the sample based on the information. In addition, it is possible (e.g., using a  
10 fifth arrangement) to scan the second electromagnetic radiation or to move the sample to probe different locations in the sample.

[0016] According to another exemplary embodiment of the present invention, the information may be related to a difference between the first and second frequencies, an optical energy associated with a particular finite group of frequency component radiations, and/or a  
15 linewidth of a plurality of the frequency component radiations, each of which may be associated with a particular frequency. This linewidth can be equivalent to a linewidth of Brillouin scattering, which may be related to an acoustic damping coefficient of the sample. In contrast, a linewidth of each frequency component radiation can be equivalent to an intrinsic spectral resolution of the second arrangement such as, e.g., a spectrometer. The  
20 retrieved information can relate to bio-mechanical properties of the sample that include but are not limited to a complex modulus of the sample, a cross linking of collagen or another anatomical structure.

[0017] In a still further exemplary embodiment of the present invention, the first arrangement can include a narrow-band spectral filter arrangement which can receive the first electro-

magnetic radiation and attenuate at least a portion thereof which has a frequency which is approximately the same as the second frequency.

[0018] Still further exemplary embodiments of the present invention can provide (e.g., using another first arrangement) for a receipt of a first electro-magnetic radiation and a second electro-magnetic radiation provided from a sample, where the first and second electro-magnetic radiations may be based on a third electro-magnetic radiation forwarded to the sample. The first electro-magnetic radiation can have a first frequency, and the second electro-magnetic radiation can have a second frequency and the third electro-magnetic radiation can have a third frequency which may be different from the first frequency. A difference between the first and third frequencies can be based on an acoustic wave inside the sample which may be related to at least one characteristic of the sample. The second electromagnetic radiation can be based on at least one of an elastic scattering, a Raman scattering or a fluorescence within the sample.

[0019] In another exemplary embodiment of the present invention, it is possible (e.g., using such other first arrangement) to separate the first and second electro-magnetic radiations into first and second frequency component radiations, respectively. A narrow band spectral separating arrangement can be provided to separate the first electro-magnetic radiation, and a broadband spectral separating arrangement configured to separate the second electro-magnetic radiation. For example, it is possible (e.g., using another second arrangement) to simultaneously detect the first and second frequency component radiations, and to generate information associated with the sample based on the first and second frequency component radiations.

[0020] In another exemplary embodiment of the present invention, it is possible (e.g., using another third arrangement) to image the portion of the sample based on the information.

[0021] These and other objects, features and advantages of the present invention will become apparent upon reading the following detailed description of embodiments of the invention, when taken in conjunction with the appended claims.

#### **BRIEF DESCRIPTION OF THE DRAWINGS**

5 [0022] Further objects, features and advantages of the present invention will become apparent from the following detailed description taken in conjunction with the accompanying figures showing illustrative embodiments of the present invention, in which:

[0023] Fig. 1 is a schematic illustration of an exemplary Brillouin effect;

[0024] Fig. 2 is a block diagram of an exemplary apparatus which includes a scanning-beam  
10 Brillouin spectroscopy arrangement in accordance with certain exemplary embodiments of the present invention;

[0025] Fig. 3A is a first schematic illustration of an exemplary embodiment of a exemplary beam focusing procedure;

[0026] Fig. 3B is a second schematic illustration of an exemplary embodiment of a beam  
15 focusing procedure;

[0027] Fig. 3C is a third schematic illustration of an exemplary embodiment of a beam focusing procedure;

[0028] Fig. 4 is a schematic illustration of a parallel detection spectrometer arrangement in accordance with exemplary embodiments of the present invention;

20 [0029] Fig. 5 is a schematic illustration of a tandem parallel detection spectrometer arrangement in accordance with exemplary embodiments of the present invention;



[0030] Fig. 6 is a schematic illustration of a narrowband spectral filter arrangement in accordance with exemplary embodiments of the present invention;

[0031] Fig. 7 is an exemplary graph of intensities of collected light in accordance with exemplary embodiments of the present invention;

5 [0032] Fig. 8 is a schematic illustration of an exemplary scanning-beam multi-modal spectroscopy – microscopy apparatus in accordance with exemplary embodiments of the present invention;

[0033] Fig. 9 is a schematic illustration of a prototype system in accordance with exemplary embodiments of the present invention;

10 [0034] Fig. 10A is an illustration of an exemplary CCD pixel index in accordance with exemplary embodiments of the present invention;

[0035] Fig. 10B is an exemplary analysis of spectral measurement of the index shown in Fig. 10A;

15 [0036] Fig. 10C is an illustration of an expanded view of a portion of the exemplary analysis of spectral measurement shown in Fig. 10B;

[0037] Fig. 11 is a further exemplary analysis of a spectral measurement in accordance with exemplary embodiments of the present invention;

[0038] Fig. 12 is an exemplary graph showing stability of a spectral analysis;

20 [0039] Fig. 13 is an exemplary graph showing a dynamic monitoring of a Brillouin shift in accordance with exemplary embodiments of the present invention;

[0040] Fig. 14A is an illustration of a biomaterial sample which was imaged in accordance with exemplary embodiments of the present invention;

[0041] Fig 14B is a first image obtained from the biomaterial sample shown in Fig. 14A in accordance with exemplary embodiments of the present invention;

5 [0042] Fig 14C is a second image obtained from the biomaterial sample shown in Fig. 14A in accordance with exemplary embodiments of the present invention;

[0043] Fig. 15A is an illustration of an exemplary Brillouin spectrum collected with a single-VIPA spectrometer in accordance with exemplary embodiments of the present invention;

[0044] Fig. 15B is an illustration of an exemplary Brillouin spectrum collected with a tandem  
10 VIPA spectrometer in accordance with exemplary embodiments of the present invention;

[0045] Fig. 16A is an illustration of the anatomy of a murine eyeball which was imaged in accordance with exemplary embodiments of the present invention;

[0046] Fig. 16B is a first exemplary measurement showing the depth profile of elasticity of a mouse eyeball measured *in vivo* in accordance with exemplary embodiments of the present  
15 invention;

[0047] Fig. 16C is a second exemplary measurement showing the depth profile of elasticity of a mouse eyeball measured *in vivo* in accordance with exemplary embodiments of the present invention;

[0048] Fig. 17 is an illustration of exemplary collagen samples and their corresponding  
20 Brillouin signatures determined in accordance with exemplary embodiments of the present invention; and

[0049] Fig. 18 is an exemplary measurement of different Brillouin signatures for different concentration of collagen samples and different degrees of collagen cross-linking determined in accordance with exemplary embodiments of the present invention.

[0050] Throughout the figures, the same reference numerals and characters, unless otherwise stated, are used to denote like features, elements, components or portions of the illustrated  
5 embodiments. Moreover, while the subject invention will now be described in detail with reference to the figures, it is done so in connection with the illustrative embodiments. It is intended that changes and modifications can be made to the described embodiments without departing from the true scope and spirit of the subject invention as defined by the appended  
10 claims.

#### **DETAILED DESCRIPTION OF EXEMPLARY EMBODIMENTS**

[0051] Fig. 1 illustrates the principle of Brillouin scattering which may be used in exemplary  
embodiments of the present invention. For example, monochromatic pump light 11 with a  
frequency  $\nu_p = \omega_p / 2\pi$  or wavelength  $\lambda_p = c / \nu_p$  can be provided incident on a medium 13  
15 to be tested. In a spontaneous version of the process, the acoustic waves, due to thermally-  
induced density fluctuations inside the medium, can generate a periodic refractive index  
variation 15. Thus, the analyzed sample can be considered as being optically equivalent to a  
grating which is traveling at the velocity of sound. The scattered light 17 has a different  
direction because of Bragg-diffraction, and may be Doppler-shifted in frequency by an  
20 acoustic wavelength. It can have a spectral linewidth which may be determined by the inverse  
of the lifetime of the measured acoustic phonon. Both Stokes and anti-Stokes components, of  
lower and higher frequencies respectively, can be equally generated in the spontaneous  
process.

[0052] The phase matching conditions between the pump and scattering light and the acoustic wave can be expressed as:

$$\omega_A = \omega_p - \omega_s ; \quad (1)$$

$$\vec{k}_A = \vec{k}_p - \vec{k}_s , \quad (2)$$

5 where  $\omega$  and  $k$  are angular frequency and wave number, respectively, and the subscript A, p, and s represent the acoustic phonons, pump and scattering (or signal) photons, respectively.

[0053] The frequency of the phase matched phonons, e.g., a difference between the pump and scattering photons, can be expressed as:

$$\nu_A = \pm \frac{2nV}{\lambda_p} \sin\left(\frac{\theta}{2}\right), \quad (3)$$

10 where  $n$  is a refractive index of the sampled material,  $V$  is a sound velocity inside the medium, and  $\theta$  is an angle between incident and scattered optical radiation. When the two waves propagate at the opposite direction, e.g.,  $\theta = 180$  deg, the magnitude of Brillouin shift can attain a maximum value.

[0054] The linewidth of Brillouin radiation can be expressed as:

$$15 \quad \Delta\nu_A = \frac{\alpha V}{\pi}, \quad (4)$$

where  $\alpha$  represents an attenuation coefficient of the sound wave inside the sample.

[0055] The magnitude of the scattered radiation can provide additional information related to the coupling of acoustic and optical energy inside the sample and can be determined by the scattering cross section  $R_B$ , as described in H. Z. Cummins and R. W. Gammon, "Rayleigh

and Brillouin Scattering in Liquids - Landau-Placzek Ratio," *Journal of Chemical Physics*, vol. 44, pp. 2785-8, 1966.:

$$R_B \equiv \frac{1}{V_{INT}} \frac{d\sigma}{d\Omega} \approx \frac{\pi^2 kT}{2\lambda_p^4} \frac{1}{\rho V^2} \left( \rho \frac{\partial \varepsilon}{\partial \rho} \right)^2, \quad (5)$$

where  $V_{INT}$  is the interaction volume inside the sample,  $k$  is the Boltzmann constant,  $T$  is the temperature,  $\rho$  is the density of the material, and  $\left( \rho \frac{\partial \varepsilon}{\partial \rho} \right)^2$  can represent an electrostriction coefficient of the material.

[0056] Once the acoustic wave is initially developed, the Brillouin phenomenon may be accelerated because of the presence of the scattered light. The scattered light, coherent with the pump light, can amplify the resonant acoustic wave which in turn enhances the Brillouin scattering. This positive feedback can result in strong Brillouin shifted scattered light, a process which may be referred to as stimulated Brillouin scattering. Typically, a Stokes Brillouin component (e.g., having a frequency down shifted) may be predominantly generated in the stimulated scattering process. The process can also be enhanced or forced when two monochromatic pump waves with frequencies separated by  $\nu_A$  are incident on a sample, as described in T. Sonehara and H. Tanaka, "Forced Brillouin Spectroscopy Using Frequency-Tunable Continuous-Wave Lasers," *Physical Review Letters*, vol. 75, pp. 4234-4237, 1995.. When the frequency difference is matched to one of the acoustic phonon frequencies in the sample, multiple Brillouin lines can be generated.

[0057] Brillouin interaction is typically a bulk phenomenon measuring bulk acoustic modes. However, as the sizes of the analyzed samples shrink or the opacity of materials increases, boundary effects can become significant in Brillouin scattering. Confined acoustic modes can be preferentially enhanced depending on the geometrical properties of analyzed environments

such as size and shape of boundaries or of their individual constituents. An example of this effect is Brillouin scattering from thin films where optical radiation can be dominantly scattered by a surface acoustic wave that determines a dynamical deformation of the sample border known as surface-ripple, as described in R. Loudon, "Theory of Surface-Ripple  
 5 Brillouin-Scattering by Solids," *Physical Review Letters*, vol. 40, pp. 581-583, 1978.. Recently, confined acoustic modes have also been observed in nanoparticles, as described in H. S. Lim, M. H. Kuok, S. C. Ng, and Z. K. Wang, "Brillouin observation of bulk and confined acoustic waves in silica microspheres," *Applied Physics Letters*, vol. 84, pp. 4182-4184, 2004.. For example, empirically, the limit on the dimensions at which bulk Brillouin  
 10 interactions may be observable has been evinced to be a few acoustic wavelengths, e.g.,  $\approx \lambda_p / 2n$ .

[0058] Brillouin spectroscopy is a technique that can measure a spectrum of Brillouin scattered light with respect to the pump waves, thereby probing the characteristics of acoustic phonons in a medium. Under certain conditions, it can serve as a mechanical fingerprint of  
 15 the medium. For example, mechanically, Brillouin scattering can monitor the stress response of a sample to a one-dimensional sinusoidal strain of high frequency (GHz). For viscoelastic materials, the stress of the sample can be determined by a complex longitudinal modulus ( $M = M' + iM''$ ) whose real part expresses the elastic response and whose imaginary part expresses the viscous response, e.g., the loss of acoustic energy in the sample. The acoustic  
 20 parameters directly measured ( $V$  and  $\alpha$ ) can be related to the longitudinal modulus through the density  $\rho$  of the material [3], e.g. :

$$M' = \rho V^2 \quad ; \quad M'' = 2\rho V^3 \alpha / v_B . \quad (6)$$

[0059] In exemplary embodiments of the present invention, a two-dimensional or three-dimensional microscopic mapping of the mechanical properties of a material, in particular a

biological sample, can be constructed by using rapidly acquired Brillouin spectroscopic signatures as contrast. In an exemplary embodiment of the present invention, a pump or probe beam may be scanned laterally across the sample and spectral patterns from each region are recorded to create an image. Light can be scanned with various conventional scanners including, e.g., galvanometer-mounted mirrors, polygonal mirror scanners and/or MEMS mirrors. Another exemplary embodiment of the present invention can use a scanning mechanism located on a fiber-optic catheter or endoscope for an application to, for example, luminal organ imaging.

[0060] In principle, three independent parameters can be extracted by each collected spectrum and can serve as contrast mechanisms for imaging: Brillouin frequency shift (Eq. 3), Brillouin linewidth (Eq. 4), and Brillouin intensity (Eq. 5). All of these three properties can have peculiar signatures (e.g., elasticity, viscosity and electrostriction, respectively) of the sampled material. Thus, three separate images can be obtained, for example, using a false color lookup table, featuring such properties. Alternatively, the three pieces of information can be used simultaneously for higher accuracy, especially at the interfaces between two different materials. For example, at the borders of the objects, a non-trivial imaging processing procedure can be applied rather than a simple false-color lookup table. At the interfaces, Brillouin lines of both materials can be measured, proportionally to the amount of incident light that excites each particular material. Therefore, rather than relying on only one of the spectral signatures, the various Brillouin lines can be discriminated, and their total strength can be accurately quantified and compared to the strength that would be observed away from an interface.

[0061] Fig. 2 depicts a block diagram of an exemplary apparatus in accordance with exemplary embodiments of the present invention. The exemplary arrangement in Fig. 2 includes a light source 21 which can act as pump beam 23 and may be delivered to the sample

25 through a beam splitter 27, a beam scanner 29, and an objective lens 31. The scattered light  
33 can be collected by the objective lens 31, which may be a first element of a microscope  
arrangement 35, to obtain spatially resolved information. Light can then be sent to a  
spectrometer 37 for spectral analysis and to a detector 39 to convert the optical information in  
5 electrical signals.

[0062] Possible light sources which may be used include, e.g., monochromatic lasers emitting  
a wavelength in the range of visible to infrared. The light source can employ an optical  
arrangement to deliver more than one frequency line. The linewidth of the laser may be  
typically less than about 1 MHz, which can provide temporal coherence longer than the  
10 lifetime of acoustic phonons. The scattered light 33 from a sample may include multiple  
frequency components originated from simple elastic scattering, as well as Brillouin  
scattering.

[0063] Exemplary applications for microscope implementation include, e.g., wide-field or  
confocal microscopy, dual-axis confocal microscopy (see T. D. Wang, M. J. Mandella, C. H.  
15 Contag, and G. S. Kino, "Dual-axis confocal microscope for high-resolution in vivo imaging,"  
*Optics Letters*, vol. 28, pp. 414-416, 2003) and/or fiber confocal microscopy. In an  
exemplary embodiment of the present invention, an epi-detection configuration may be used  
in which a backward-propagating Brillouin light 33 is collected by the same lens 31 used for  
illumination. Epi-detection can take advantage of an intrinsic property of Brillouin scattering,  
20 e.g., the scattered signal wave can be a phase conjugate to the pump wave. This property may  
enhance the collection efficiency of the Brillouin wave through a turbid medium such as  
tissue.

[0064] Exemplary focusing mechanisms are shown in Fig. 3. For coarse resolutions, a  
collimated pump beam with a relatively small beam diameter may be used. However, for



three dimensional resolutions, the pump/probe beams can be focused to a sample by the use of objective lenses. In the exemplary configuration of Fig. 3A, objective lenses with low numerical aperture (NA) 51 can result in a low transverse resolution, but the longitudinal interaction length may be long and well-defined. In Fig. 3B, objective lenses 53 having a high NA may provide better transverse and axial resolution. Since the Brillouin interaction length can be short and the interaction can be made over a large solid angle, the phase matching condition may become less stringent. This condition can broaden the linewidth of the scattered light, thereby affecting the strength of Brillouin signal and the accuracy of the spectral analysis, as described in Danielme.Hg, "Aperture Corrections for Sound-Absorption Measurements with Light Scattering," *Journal of the Acoustical Society of America*, vol. 47, pp. 151-&, 1970.

[0065] More than one pump beam may be provided using multiple objective lenses. Fig. 4C depicts an exemplary embodiment of the present invention using two objective lenses 55, 57. This scheme, however, may not be suitable for *in vivo* biomedical applications. Confocal techniques can be used to enhance depth sectioning. For example, a dual-axis confocal configuration can maximize axial resolution for a given NA and at the same time allows areduction of back-reflections and elastic scattering components. A fiber arrangement can also be used, for example, by having a single-mode fiber as confocal pinhole. Acting as tight spatial mode filter, the fiber can provide strict confocal imaging which may reduce the amount of stray or spurious unwanted radiation.

[0066] The requirements on spectral analysis for Brillouin spectroscopy can be stringent because 0.1 GHz to 50 GHz features may be resolved. High spectral resolution and rapid analysis can be essential to facilitate imaging capabilities as well as dynamic studies.

[0067] High resolution and simultaneously high sensitivity in the spectral analysis can be important. Fabry-Perot interferometry can be used for the spectral analysis of Brillouin signal in both scanning (see J. R. Sandercock, "Some Recent Developments in Brillouin-Scattering," *Rca Review*, vol. 36, pp. 89-107, 1975) and non-scanning configurations (as described in K. J. Koski, J. Muller, H. D. Hochheimer, and J. L. Yarger, "High pressure angle-dispersive Brillouin spectroscopy: A technique for determining acoustic velocities and attenuations in liquids and solids," *Review of Scientific Instruments*, vol. 73, pp. 1235-1241, 2002). Fabry-Perot scanning interferometers can have very high resolution. However, they can be intrinsically slow because they perform the spectral analysis in a sequential manner by measuring the energy of the various frequency components one at a time. Non-scanning (or angle-dispersive) Fabry-Perot interferometry may be faster because it can measure all frequency components at once in a parallel fashion using an array of detectors. However, angle-dispersive Fabry-Perot interferometry may also have intrinsic limitations in sensitivity as described below.

[0068] In angle-dispersive Fabry-Perot spectroscopy, the spectral separation can be determined by the interference of multiple reflections at two optical mirrors. Two interference patterns can be formed, one in transmission and one in reflection, but only the transmission pattern may be measured by the detecting device. All energy of the reflected interference pattern can be lost, thereby hindering the sensitivity of the spectrometer.

[0069] The maximum amount of light that may be forwarded to the detector in this configuration can be easily quantified. The resolution performance of spectrally dispersive elements can be characterized by a parameter known as finesse ( $f$ ), which may be defined as a ratio of the separation between different orders of diffraction to the linewidth of an individual resolved line. The finesse  $f$  can be similar to the number of spectral components can be

resolved; e.g.,  $f = N$ . A higher finesse can correspond to a higher resolution of the spectral dispersive element.

[0070] However, in angle dispersive Fabry-Perot interferometry, for each frequency component that is discriminated in the transmitted pattern, a certain, proportional, amount of light may be lost in the reflected pattern. Thus, a higher finesse can correspond to a lower total light throughput. If  $f$  is the finesse of the angle-dispersive Fabry-Perot interferometer, then a maximum of  $1/f$  of the input light can be sent to the detecting device. This is a limit which does not include other practical loss mechanisms. The  $1/f$  throughput limit can be overcome by various other spectral dispersive elements such as, e.g., diffraction gratings or prisms, but such devices cannot provide the high resolution needed for Brillouin spectroscopy.

[0071] The simultaneous requirements of resolution and light throughput can be met by a fully parallel-detection spectroscopic technique. A preferred solution for such spectroscopy is shown in Fig. 4, which includes a diffractive tilted etalon 71, e.g., a virtually-imaged phased array (VIPA) (see M. Shirasaki, "Large angular dispersion by a virtually imaged phased array and its application to a wavelength demultiplexer," *Optics Letters*, vol. 21, pp. 366-368, 1996), in combination with an array-type detector such as a CCD camera. Light can be focused on the VIPA element 71 by a cylindrical lens 75 while light is collected from the VIPA 71 onto the CCD by another lens 77. The VIPA spectrometer can achieve high spectral resolution with high temporal resolution. As in angle-dispersive Fabry-Perot spectroscopy, the spectral selection can be provided by the interference of multiple reflections at two optical flats, yielding equivalent performances in terms of resolution. Unlike Fabry-Perot etalons, however, the first surface can be totally reflective but may be cut (or coated) to allow all the light to enter the interferometer. Besides minimizing losses, this design can avoid useful light being wasted in a reflected interference pattern. As a consequence, with respect to an

equivalent Fabry-Perot spectrometer, the signal strength can be improved by a factor  $f$  equal to the finesse of the interferometer. Such improvement in light throughput of the spectrometer can allow real time monitoring of dynamical processes such as collagen cross-linking.

[0072] the exemplary VIPA spectrometer generally may have a limited resolution of about 1  
5 GHz and a limited extinction efficiency of about 30 dB (1 over a thousand) and, as a result, may be effective only for optically transparent samples. In a turbid sample such as a biological tissue, elastic (Rayleigh) scattering can be several orders of magnitude stronger than Brillouin scattering and is separated by only a few GHz from Brillouin signal. For this reason, additional spectral selection may be preferable. Possible solutions include diffraction  
10 gratings, fiber Bragg gratings, or notch filters based on narrow absorption line of gas cells. Two further procedures may be used, e.g., a multiple VIPA spectrometer and a spatial-to-spectral VIPA notch filter.

[0073] Fig. 5 shows a schematic illustration of an exemplary embodiment of a tandem-VIPA spectrometer. The exemplary role of the first-stage VIPA 91 in this figure can be to provide  
15 spectral dispersion along a vertical axis. A lens 93 can transfer this vertically dispersed beam to the second stage VIPA 95. The second-stage VIPA can further disperse the beam, but along the horizontal direction. After the second stage, the tail of the Rayleigh spectrum, which had been overlapped with Brillouin peaks, may be separated from the Brillouin signals. The resulting spectrum can be imaged by a lens 97 onto a 2D CCD array 99 or a 1D array oriented  
20 at 45 degrees. A spatial mask may be placed to reject Rayleigh light and to prevent it from entering the second VIPA. The addition of the second VIPA may likely lead to an about 20-25 dB improvement of contrast suppression.

[0074] This approach can be extended further to three or more VIPA stages to improve contrast, but additional stages may increase optical loss. Besides the intrinsic losses of a

VIPA, a single VIPA stage can produce multiple diffraction orders, but only one or a few of them may be transferable to another VIPA at the next stage. Even with optimal optical design, a total loss of 6 to 10 dB may result. These additional losses can be compensated by increasing CCD integration time or by spectrum averaging. Moreover, improving the  
5 extinction of the spectrometer greatly reduces the problem arising from the backscattered light, thereby allowing for more efficient collection procedures.

[0075] Fig. 6 shows an exemplary spatial-to-spectral VIPA notch filter that can be used to selectively attenuate Rayleigh light with respect to Brillouin light. For example, the output of the collection optical system 111 can enter a VIPA 113 and become spectrally separated. A  
10 spatial mask 115 can be placed at the back focal plane of an imaging lens 117 and may block the Rayleigh light. The rest of the spectrum can be reflected by a mirror 119 and combined by the same VIPA 113 to exit the device 121 unchanged, apart from being spectrally filtered. Combining a polarization beam splitter 123 and a quarter wave plate 125 can eliminate beam-splitting loss. An additional extinction efficiency of ~20 dB can be expected by such spectral  
15 notch filter.

[0076] For specific situations in which high spectral resolution and contrast are needed a scanning filter such as a Fabry-Perot interferometer can be used. The Fabry-Perot scanning interferometer may have a free spectral range of 50 GHz, and finesse of 1000; it can operate in single-pass configuration or in multipass, fixed or tandem, to enhance contrast.  
20 Alternatively, a fixed filter with a bandpass, notch, or edge type may be used, instead of a scanning filter, to measure the magnitude of certain frequency components. However, an optical frequency of the pump wave should be stabilized or locked with respect to the fixed filter.

[0077] Further exemplary embodiments of the present invention can be provided which combine exemplary embodiments described herein above with different spectral modalities. For example, once light is delivered to a material, the light collected from the sample can include various components arising from different phenomena which may carry independent  
5 information about the sample under study.

[0078] Fig. 7 shows an example of various components of such collected light separated by their frequency shift with respect to the incoming light. For example, reflected light 131, unshifted in frequency, can provide information about the structure of the sample as a standard reflectance confocal microscope might do. A Brillouin component 133 can provide  
10 mechanical information about the sample. Raman components 135 can arise from vibrational phonons of the analyzed material, and thus yield chemical information about its constituents. Fluorescence 137, either endogenous or induced by the introduction of fluorophores, can help identify particular elements in the material and can provide functional information about the sample under scrutiny. In addition, in Brillouin spectral region, Raman scattering arising  
15 from rotational degrees of freedom of the sample can be analyzed as well as Rayleigh-Wing scattering, a process related to the optical anisotropy of the material, e.g., the fluctuations in the orientation of its molecules. Reflectance, Raman and fluorescence spectroscopy can be used individually for imaging purposes, and a combination of two or more of such modalities may also be used.

[0079] In exemplary embodiments of the present invention, a combination of Brillouin microscopy with other modalities can be provided. An exemplary block diagram of such multi-modal microscopy via the simultaneous implementation of Brillouin as well as Raman and fluorescence spectroscopy is shown in Fig. 8. For example, fluorescence, Raman and Brillouin spectra can be in different regions of the electromagnetic spectrum after passing  
25 through the collection optics 151. Scattered and fluorescent light 153 can undergo a coarse

spectral dispersion 155 to separate the Brillouin, reflectance and rotational Raman components 157 from the fluorescence and vibrational Raman beam components 159. Possible solutions for such coarse spectral dispersion can include, but are not limited to, gratings, dichroic mirrors and/or interferometric bandpass filters.

5 [0080] Beam 157, containing Brillouin reflectance and rotational Raman information, can be analyzed by a spectrometer 161 and a detector 162. Exemplary solutions for this analysis can include various spectrometers as described herein above. Beam 159, containing fluorescence and Raman scattering, can be further spectrally separated by a dispersive element 163, whose  
10 exemplary implementations are gratings, bandpass filters, prisms or other conventional spectral dividing methods. The fluorescence beam 165 is collected and measured by a detector 167; the vibrational Raman component 169 is collected and measured by a detector 171. Exemplary solutions for detectors 169, 171, 162 include, but are not limited to, photomultiplier tubes or photodiodes, or they can be combined in a single array detector such as, e.g., a CCD camera. Such detectors can allow delivery of Raman, Brillouin and  
15 fluorescent information simultaneously to the same computer 173.

[0081] This multi-modality technique and apparatus can be particularly advantageous because, as previously stated, the various processes can be used to sample independent and diverse characteristics of a given material, thus yielding mechanical as well as optical and/or chemical information about the analyzed sample.

20 [0082] Fig. 9 is a schematic diagram of a prototype instrument according to an exemplary embodiment of the present invention. Such instrument includes a light source, imaging optics, a spectrometer, and a computer. The light source is a frequency-doubled diode-pumped Nd-YAG laser emitting, e.g., a 532-nm wavelength with a linewidth of 1 MHz (Laser Quantum, Inc.) Light is focused on a sample through a 30 mm focal length lens. A dual-axis

confocal geometry with a free-space entrance angle of about 6 degrees was chosen to minimize back-reflections and achieve higher sectioning capabilities with low numerical apertures (0.03). Scattered light is collected through the same lens. A single mode fiber is then used as confocal pinhole. This allows for strict confocal imaging because the fiber is effectively a single-mode spatial filter, thus it minimizes stray light. The output of the fiber is spectrally filtered by a 3 nm bandpass filter, mainly to avoid fluorescence from the samples. Light is then coupled into the VIPA spectrometer for high spatial separation of the spectral components in the plane of an Electron-Multiplied CCD camera. The optical design of the spectrometer, with the combination of input cylindrical lens before the VIPA and spherical lens after the VIPA as well as CCD binning, can maximize the SNR of the setup by achieving one-dimensional spectral dispersion. According to one exemplary embodiment of the present invention, it is possible to utilize a number of types of VIPA, e.g., (a) a custom-built 3-mm solid etalon made of fused silica, as shown in Fig. 4, with coatings of about  $R_1=99.9\%$ ; about  $R_2=95\%$ , about  $FSR=33$  GHz and finesse between about 40 and 60; and (b) a home-built air-spaced VIPA which can include two mirrors (e.g.,  $R_1=99.9\%$ ;  $R_2=95\%$ ), variable FSR between about 1 and 40 GHz and finesse between about 10 and 20. The exemplary total light throughput of an exemplary VIPA spectrometer can be as high as 75% .

[0083] A typical spectrum recorded from water in 1 s under 10 mW of illumination power is shown in Figs. 10A-10C. Several diffraction orders are visible in the CCD retrieved image shown in Fig. 10A. Fig. 10B shows the central peak in each order, which can correspond to the elastic Rayleigh scattering, and the ancillary peaks on the right and on the left which can correspond to Stokes and anti-Stokes components of Brillouin scattering. The acquired spectrum can be mapped onto an actual frequency scale as shown, e.g., in Fig. 10C, to allow for the evaluation of Brillouin frequency shift and linewidth.



[0084] Several spectra acquired from different materials using this prototype instrument are shown in Fig. 11. Among the various samples examined, BaBb (2:1 solution of Benzene and Benzyl alcohol) may be particularly relevant for future biological studies because it is a clearing agent widely used to achieve optical transparency in numerous biological samples.

5 The experimental data (dots) are fitted to a triplet of Lorentzian functions (solid line) while a fit of the single Stokes Brillouin line is shown by the dashed lines. Plexiglas has a Brillouin shift very close to half the FSR of the spectrometer. Thus, Brillouin peaks from neighbor orders may also be visible. The graphs shown in Fig. 11 suggest that some materials, e.g., Toluene and BaBB, can exhibit a measurable background arising from Rayleigh-wing

10 scattering. The measured spectral width of Rayleigh-wing scattering in Toluene ( $8 \text{ cm}^{-1}$ ) is consistent with previously observed data, as described in K. J. Koski, J. Muller, H. D. Hochheimer, and J. L. Yarger, "High pressure angle-dispersive Brillouin spectroscopy: A technique for determining acoustic velocities and attenuations in liquids and solids," *Review of Scientific Instruments*, vol. 73, pp. 1235-1241, 2002. Acquiring several spectra from

15 different known materials can be used to calibrate spectral separations with respect to the actually observed spatial discrimination of different peaks, as described in the K. J. Koski reference. A linear relationship can be observed between measured pixel separation and literature data on Brillouin frequency shifts. Using the slope of such curves, the spectrometer can be calibrated. With such calibration, the Brillouin analysis on elasticity and viscosity

20 retrieval can exhibit agreement with reported values. as described in the H. Z. Cummins and R. W. Gammon reference, the K. J. Koski reference, and G. W. Faris, L. E. Jusinski, and A. P. Hickman, "High-Resolution Stimulated Brillouin Gain Spectroscopy in Glasses and Crystals," *Journal of the Optical Society of America B-Optical Physics*, vol. 10, pp. 587-599, 1993

[0085] Fig. 12 shows a histogram of the occurrence of retrieved shifts as recorded over time

25 from the same sample in the same experimental condition. This histogram thereby indicates

the stability of Brillouin spectral analysis. The material used for this measurement is cured, fully solid, epoxy resin. Based on the histogram, the sensitivity of the instrument in the frequency (and thus elasticity) evaluation can be estimated (in this case, e.g., the sensitivity is about  $20 \text{ MPa}/\sqrt{\text{Hz}}$ ).

5 [0086] Rapid data acquisition achievable by parallel detection can be critical for following dynamic processes that may change the elastic properties of materials in real time. Such a capability is shown in Fig. 13 with respect to a UV curable epoxy resin sample. A UV lamp was used for this measurement, characterized by an output of  $90 \text{ mW}/\text{cm}^2$  in the 300 nm-400 nm wavelength range, and placed 8 cm away from the sample. At time  $t = 0$ , a UV lamp was  
10 turned on to begin curing the resin. The measurement of Brillouin shifts over time reveals rapid changes under UV light as well as a slow curing process afterward. No curing effect was observed based on the incident green light, as suggested by the Brillouin signatures for  $t < 0$ . The elastic modulus changed from 4.5 GPa when uncured to 9 GPa after fully cured over 1 day.

15 [0087] No previous data was available for comparison to such observations. However, the experimental result corresponds to the expected time-dependent curing process, because UV curing can induce crosslinking in a polymer adhesive and thereby increase its modulus. This experiment demonstrates the capability of exemplary embodiments of the present invention to monitor mechanical changes associated with crosslinking of a polymer with a high sensitivity  
20 (e.g.,  $40 \text{ MPa}/\sqrt{\text{Hz}}$ ) and a high temporal resolution (e.g., about 1 sec).

[0088] Three-dimensional Brillouin microscopy can be achieved using exemplary embodiments of the present invention that include a confocal arrangement. For imaging, Brillouin spectra can be acquired continuously as the sample is translated with respect to the beam focus. The spatial resolution of an exemplary confocal apparatus was observed to be

about 6  $\mu\text{m}$  in a transverse direction and 60  $\mu\text{m}$  in an axial direction. Resolution measurements were obtained by recording Brillouin frequency shifts at the interface of two materials by over-sampling the acquisition data to a much smaller step than the actual resolution. At the interface of two materials, Brillouin signatures from both materials were  
5 observed, having different strengths depending on the amount of light that is shining onto a particular material. A meaningful parameter retrieved for such measurement can be a ratio between Brillouin signal amplitudes in the two frequency regimes that correspond to the two different materials.

[0089] To demonstrate cross-sectional imaging, an intraocular polymer lens, e.g., a popular  
10 biomedical implant used to replace a human crystalline lens, was used as a sample. The intraocular lens is made of acrylate-methacrylate copolymer with bonded UV absorber and blue-light filtering chromophore (transmission of about 90% at 532nm) to mimic the performance of human lenses. To minimize backscattering and back-reflections, the intraocular lens was placed in a bath of epoxy resin of similar refractive index, inside a plastic cuvette, and the  
15 sample was slightly tilted with respect to the optical axis as shown in Fig 14A. Such tilting can be seen by analyzing the processed image of the lens in Fig. 14B and 14C. To expedite the image acquisition and avoid unwanted curing effects in the resin, all the data of this experimental run were taken with 3.5 mW of illuminating power and 0.5 seconds of exposure time.

20 [0090] Figs. 14B and 14C depict exemplary processed cross sectional images of an x-z plane of the lens. In Fig. 14B, Brillouin frequency shifts are color mapped vs. spatial position inside the sample. In Fig. 14C, the normalized Brillouin signal amplitude at a given frequency shift is color mapped vs. spatial position. As suggested by Eq. (5), Brillouin amplitude, which can be related to a material coupling of acoustic and optical energy, may be peculiar to each

medium and can be used as additional signature for material discrimination. The biconvex shape of the lens can be distinguished in these images, as well as small dust particles on the lens surface and the plastic cuvette in the top left corner.

[0091] Certain previous exemplary data have been collected with a single VIPA spectrometer. Thus, such data may be limited to optical transparent samples. According to one exemplary embodiment of the present invention, by using an exemplary tandem VIPA spectrometer, the extinction can be improved significantly and therefore more scattering samples can be analyzed. Figs. 15A-15C show exemplary acquired Brillouin spectrum for Methanol using a single (see Fig. 15A) vs a tandem (see Fig. 15B) VIPA spectrometer featuring substantially two identical VIPAs with FSR= about 33 GHz and nominal coating reflectivities of about 99.9% and 95%. At half FSR, the extinction for a single VIPA spectrometer can be estimated to be about 34dB, with one for a tandem VIPA spectrometer possibly approaching about 59dB. The total throughput of a tandem VIPA spectrometer can typically be about 50%.

[0092] Using an exemplary tandem VIPA spectrometer, it may be possible to measure, e.g., the Brillouin signature from crystalline lens of a mouse eye *in vivo*. Fig. 16A depicts the exemplary geometry of the measurement and the exemplary anatomy of the murine eyeball. For example, a coverslip may be placed on the anterior surface of the cornea with methylcellulose to minimize the corneal refraction. The laser beam may enter the crystalline lens through the center of the pupil. It is possible to acquire Brillouin spectra along the optic axis of the eye, e.g., at a depth interval of about 100  $\mu\text{m}$ , with approximately 5-mW optical power and about 3-s integration time. Fig. 16B depicts the exemplary measured Brillouin frequency shift in an 18-month-old C57BL/6 mouse. For example, the Brillouin shifts of the aqueous and vitreous humors may be close to the one typical of distilled water. In the crystalline lens, the Brillouin shift can increase from the outer layers (cortices) toward the

center (nucleus). This exemplary result may be consistent with previous measurements of excised lenses *in vitro* (see Ref. [1]), obtained using a multipass F-P scanning interferometer with higher power levels of about 10-25 mW and a longer integration time of about 10 min per spectrum. Fig. 16C depicts a similar measurement as that performed shown in Fig. 16B  
5 except that it was performed on a 1-month-old C57BL/6 mouse. The basic features of the measurement remain mostly the same, other than the physiological enlargement of the physical size of the eye. However, the stiffness of the crystalline lens is likely remarkably higher in the older mouse. This measurement likely indicates the ability of our instrument to detect changes in the mechanical properties of crystalline lenses with age, and illustrates the  
10 likely use of the exemplary embodiments of the present invention, e.g., for ophthalmology studies related for example to presbyopia, cataracts, refractive surgery, etc.

[0093] Based on such exemplary data, Brillouin Microscopy can be used as a preferable non-invasive diagnostic tool in, e.g., ophthalmology for early diagnosis, treatment evaluation and scientific understanding of ocular diseases such as presbyopia and cataracts. The exemplary  
15 embodiments of the present invention can also be used for various other applications, including and not limited to, e.g., auxiliary instruments for surgical treatments of cataracts, to monitor the procedure and/or evaluate pre- and post- surgical biomechanical signatures.

[0094] Exemplary embodiments of the present invention can be used in a variety of fields other than ophthalmology, as indicated by the preliminary exemplary data obtained using the  
20 exemplary embodiment of the system described herein above. One such exemplary application may be, e.g., to follow real-time dynamical changes of mechanical properties of a material which can occur, e.g., in tissue engineering.

[0095] For instance, injury to articular cartilage is a common orthopedic problem, with more than one million surgical procedures being performed in the United States each year. Tissue

engineering offers new strategies for repairing cartilage, for example, by using chondrocytes and scaffolds to promote a formation of new cartilage matrix that closely resembles native tissue. Cartilage has an important biomechanical function. Consequently, the biomechanical properties of a scaffold and the micromechanical environment it provides for the implanted  
5 cells can play a significant role in cartilage repair. Although conventional mechanical testing techniques are widely used for such scaffolds, they can be invasive, time consuming, and difficult to use *in situ* and *in vivo*.

[0096] Exemplary embodiments of the present invention may facilitate more sophisticated studies and uses, such as characterizing the micromechanical environment of implanted  
10 chondrocytes and their effects on new cartilage formation *in vivo* and over time. In order to assess the feasibility of applying dynamic visco-elastic characterization for such cartilage formation, Brillouin spectra of a type-I collagen gel (0.8wt%) in 0.02N acetic acid solution and a photochemically cross-linked collagen-riboflavin mixture were measured. Fig. 17 shows exemplary measured Brillouin spectra. The large peaks centered at CCD pixel numbers  
15 409, 437, and 465 correspond to elastic Rayleigh scattering, whereas other peaks in between originated from inelastic Brillouin scattering. Rayleigh scattering in the collagen solution was substantially stronger than that in water, producing larger background under the Brillouin peaks. Nevertheless, well-defined Brillouin peaks are observed with Brillouin shifts nearly the same as that of water, consistent with the high water content (~99%) in the gel. Additional  
20 peaks at a shift of about 3.5 GHz are also observed, although it may not be clear what these peaks represent. Mixing collagen gel with riboflavin further increased the Rayleigh peak (data not shown).

[0097] Crosslinking of the gel was induced by illuminating with blue light for 40 sec. After crosslinking, strong Rayleigh scattering, appreciable even with the naked eye, was observed

to dominate nearly the entire spectral window, which may prohibit an accurate detection of Brillouin peaks.

[0098] A tandem VIPA spectrometer may have a certain amount of a extinction to measure collagen cross-linking. In order to demonstrate this ability, it is possible to prepare two acidic solutions with about 3% and 6% collagen, and measure their Brillouin signatures with and without crosslinking. In this exemplary case, it may be preferable to use, e.g., Rose Bengal as a photo sensitizer; and the curing may occur with, e.g., 532 nm laser light. Fig. 18 depicts the exemplary results of this measurement. For example, 50 measurements with 10 mW illumination power and 2 seconds exposure may be preformed for each sample. As shown in Fig. 18, the exemplary embodiment of the apparatus according to the present invention is able to discriminate between, e.g., the control (non-cross-linked sample) and the cross-linked ones. In addition, a distinction can be seen between the 3% and the 6% solution, e.g., showing enough sensitivity of the exemplary instrument to discriminate different tissue engineering compounds.

[0099] Based on this exemplary data, Brillouin microscopy may be useful, e.g., in reviewing and determining the mechanical properties and their effects on chondrocytes-encapsulated collagen scaffolds and neocartilage formation *in vitro* as well as *in vivo*. Exemplary embodiments of the present invention may further be used to characterize living cells and tissues. However, stronger Rayleigh scattering arises in cells and tissue. An additional Rayleigh rejection efficiency of about 20-25 dB can be sufficient for tissue studies. Exemplary data may indicate that triple-VIPA spectrometer can be sufficient to achieve such exemplary task. Thus, Brillouin microscopy may be applied to biological tissues successfully. Water has a bulk modulus,  $E$ , of about 2.2 GPa at room temperature and a density,  $\rho$ , of about 1 g/cm<sup>3</sup>. Thus, e.g., at  $\lambda=532$  nm,  $n=1.33$ , and  $\theta=0^\circ$ , and  $\Delta\nu = 7.5$  GHz. Since water is the most abundant molecule in biological tissue, studies show that biological

tissue can exhibit Brillouin shifts in a range of about 2–20 GHz at  $\lambda=532$  nm, as described in the J. M. Vaughan and J. T. Randall publication and the R. Harley, D. James, A. Miller, and J. W. White publication. Most biopolymers, such as PMMA or acrylate polymer, have Brillouin shifts also in the GHz range. Non-isotropic samples such as muscle or collagen fibers can produce multiple Brillouin shifts, which may depend on the scattering direction with respect to their symmetry axes, as described in N. Berovic, N. Thomas, R. A. Thornhill, and J. M. Vaughan, "Observation of Brillouin-Scattering from Single Muscle-Fibers," *European Biophysics Journal with Biophysics Letters*, vol. 17, pp. 69-74, 1989. .

[00100] The energy of an acoustic wave involved in spontaneous Brillouin scattering may be too weak to cause any significant biological perturbation. The Young's modulus and damping coefficient of a viscoelastic sample may be frequency dependent. Thus, such parameters measured by Brillouin spectroscopy in the GHz frequency range may be different from those measured by conventional strain-stress test or dynamic mechanical analysis, which may be typically performed from 0 Hz (e.g., using DC signals) to 100 Hz, as described in R. L. Y. Sah, Y. J. Kim, J. Y. H. Doong, A. J. Grodzinsky, A. H. K. Plaas, and J. D. Sandy, "Biosynthetic Response of Cartilage Explants to Dynamic Compression," *Journal of Orthopaedic Research*, vol. 7, pp. 619-636, 1989. . Most biological tissue and biopolymers can be viscoelastic and, consequently, the elasticity may vary considerably with strain rate and temperature. Therefore, it can be important to establish a correlation between Brillouin measurements and conventional mechanical measurements. In contrast, water has a very rapid relaxation time, shorter than about 10 ps, so its elastic modulus may not vary much from 0 Hz to 10 GHz.

[00101] Measuring viscoelastic properties of living tissues using Brillouin microscopy can provide a useful clinical non-invasive tool for the detection of early-stage cancers or intra-operative determination of tumor margins. Tumors may be generally stiffer than surrounding



healthy tissue, and a Brillouin spectrum of a tumor can thereby exhibit a stronger magnitude than normal tissues at high frequencies . Atherosclerosis is another medical area the Brillouin microscopy may be used for characterizing stress and tissue compliance, e.g., to help identify plaques which may be at risk for causing an acute coronary event.

5 [00102] [0055] The foregoing merely illustrates the principles of the invention. Various modifications and alterations to the described embodiments will be apparent to those skilled in the art in view of the teachings herein. Indeed, the arrangements, systems and methods according to the exemplary embodiments of the present invention can be used with any OCT system, OFDI system or other imaging systems, and for example with those  
10 described in U.S. Provisional Patent Appn. No. 60/514,769 filed October 27, 2003, and International Patent Application No. PCT/US03/02349 filed on January 24, 2003, the disclosures of which are incorporated by reference herein in their entireties. It will thus be appreciated that those skilled in the art will be able to devise numerous systems, arrangements and methods which, although not explicitly shown or described herein, embody the principles  
15 of the invention and are thus within the spirit and scope of the present invention. In addition, to the extent that the prior art knowledge has not been explicitly incorporated by reference herein above, it is explicitly being incorporated herein in its entirety. All publications referenced herein above are incorporated herein by reference in their entireties. Exemplary references cited herein are as follows:

20 [1] J. M. Vaughan and J. T. Randall, "Brillouin-Scattering, Density and Elastic Properties of the Lens and Cornea of the Eye," Nature, vol. 284, pp. 489-491, 1980.

[2] R. Harley, D. James, A. Miller, and J. W. White, "Phonons and Elastic-Moduli of Collagen and Muscle," Nature, vol. 267, pp. 285-287, 1977.

- [3] J. Randall and J. M. Vaughan, "Brillouin-Scattering in Systems of Biological Significance," *Philosophical Transactions of the Royal Society of London Series a-Mathematical Physical and Engineering Sciences*, vol. 293, pp. 341-348, 1979.
- [4] H. Z. Cummins and R. W. Gammon, "Rayleigh and Brillouin Scattering in Liquids - Landau-Placzek Ratio," *Journal of Chemical Physics*, vol. 44, pp. 2785-&, 1966.
- [5] T. Sonehara and H. Tanaka, "Forced Brillouin Spectroscopy Using Frequency-Tunable Continuous-Wave Lasers," *Physical Review Letters*, vol. 75, pp. 4234-4237, 1995.
- [6] R. Loudon, "Theory of Surface-Ripple Brillouin-Scattering by Solids," *Physical Review Letters*, vol. 40, pp. 581-583, 1978.
- 10 [7] H. S. Lim, M. H. Kuok, S. C. Ng, and Z. K. Wang, "Brillouin observation of bulk and confined acoustic waves in silica microspheres," *Applied Physics Letters*, vol. 84, pp. 4182-4184, 2004.
- [8] T. D. Wang, M. J. Mandella, C. H. Contag, and G. S. Kino, "Dual-axis confocal microscope for high-resolution in vivo imaging," *Optics Letters*, vol. 28, pp. 414-416, 2003.
- 15 [9] Danielme.Hg, "Aperture Corrections for Sound-Absorption Measurements with Light Scattering," *Journal of the Acoustical Society of America*, vol. 47, pp. 151-&, 1970.
- [10] J. R. Sandercock, "Some Recent Developments in Brillouin-Scattering," *Rca Review*, vol. 36, pp. 89-107, 1975.
- [11] K. J. Koski, J. Muller, H. D. Hochheimer, and J. L. Yarger, "High pressure angle-dispersive Brillouin spectroscopy: A technique for determining acoustic velocities and  
20 attenuations in liquids and solids," *Review of Scientific Instruments*, vol. 73, pp. 1235-1241, 2002.

- [12] M. Shirasaki, "Large angular dispersion by a virtually imaged phased array and its application to a wavelength demultiplexer," *Optics Letters*, vol. 21, pp. 366-368, 1996.
- [13] H. Tanaka and T. Sonchra, "New Method of Superheterodyne Light Beating Spectroscopy for Brillouin-Scattering Using Frequency-Tunable Lasers," *Physical Review Letters*, vol. 74, pp. 1609-1612, 1995.
- [14] G. W. Faris, L. E. Jusinski, and A. P. Hickman, "High-Resolution Stimulated Brillouin Gain Spectroscopy in Glasses and Crystals," *Journal of the Optical Society of America B-Optical Physics*, vol. 10, pp. 587-599, 1993.
- [15] N. Berovic, N. Thomas, R. A. Thornhill, and J. M. Vaughan, "Observation of Brillouin-Scattering from Single Muscle-Fibers," *European Biophysics Journal with Biophysics Letters*, vol. 17, pp. 69-74, 1989.
- [16] R. L. Y. Sah, Y. J. Kim, J. Y. H. Doong, A. J. Grodzinsky, A. H. K. Plaas, and J. D. Sandy, "Biosynthetic Response of Cartilage Explants to Dynamic Compression," *Journal of Orthopaedic Research*, vol. 7, pp. 619-636, 1989.

**WHAT IS CLAIMED IS:**

1. An apparatus comprising:

at least one first arrangement configured to receive at least one first electro-magnetic radiation provided from a sample which is based on at least one second electro-magnetic radiation forwarded to the sample, wherein the at least one first electro-magnetic radiation has a first frequency and the at least one second electro-magnetic radiation has a second frequency which is different from the first frequency, and wherein a difference between the first and second frequencies is based on an acoustic wave inside the sample related to at least one characteristic of the sample;

10 at least one second arrangement configured to receive at least one third electro-magnetic radiation from the at least one first arrangement which is based on the at least one first electro-magnetic radiation and separate the at least one third electro-magnetic radiation into a particular finite number (N) of frequency component radiations; and

15 at least one third arrangement configured to receive a particular energy of more than  $1/N$  of energy of the at least one third electro-magnetic radiation, and generate information associated with the sample.

2. The apparatus according to paragraph 1, wherein the at least one third arrangement is configured to receive the particular energy of at least one particular radiation of the frequency component radiations.

20 3. The apparatus according to paragraph 1, wherein the at least one third arrangement includes an array of detectors.

4. The apparatus according to paragraph 1, wherein the at least one second arrangement includes a virtually imaged phased array.

5. The apparatus according to paragraph 1, wherein the particular number is between about 10 and 100.
6. The apparatus according to paragraph 1, wherein the at least one third arrangement is configured to simultaneously receive a plurality of the frequency component radiations.
- 5 7. The apparatus according to paragraph 1, wherein the at least one first arrangement includes a narrow-band spectral filter arrangement which receives the at least one first electro-magnetic radiation and attenuates at least one portion thereof which has a frequency which is approximately the same as the second frequency.
8. The apparatus according to paragraph 1, wherein the at least one first arrangement  
10 includes a single-mode optical fiber arrangement.
9. The apparatus according to paragraph 1, wherein the at least one first arrangement includes a confocal arrangement.
10. The apparatus according to paragraph 1, wherein a resolvable linewidth of at least one frequency component radiation is less than 2 GHz.
- 15 11. The apparatus according to paragraph 1, further comprising at least one fourth arrangement configured to image the at least one portion of the sample based on the information.
12. The apparatus according to paragraph 11, wherein the information includes a difference between a frequency of at least one of the frequency component radiations and the  
20 second frequency.
13. The apparatus according to paragraph 12, wherein the difference is between approximately  $-100$  GHz and  $+100$  GHz.

14. The apparatus according to paragraph 11, wherein the information includes an energy of each of the frequency component radiations.
15. The apparatus according to paragraph 11, wherein the information includes a linewidth of a plurality of the frequency component radiations each of which being associated  
5 with a particular frequency.
16. The apparatus according to paragraph 11, wherein the information includes at least one characteristic of the sample.
17. The apparatus according to paragraph 16, wherein the at least one characteristic includes at least one bio-mechanical property of the sample.
- 10 18. The apparatus according to paragraph 17, wherein the at least one bio-mechanical property includes complex viscoelastic modulus.
19. The apparatus according to paragraph 16, wherein the at least one characteristic includes a crosslinking of collagen in the sample.
20. The apparatus according to paragraph 11, wherein the sample includes at least one of  
15 an anatomical structure or a biomaterial.
21. The apparatus according to paragraph 1, further comprising at least one fifth arrangement configured to deliver the at least one second electro-magnetic radiation to the sample.
22. The apparatus according to paragraph 21, wherein the at least one fifth arrangement  
20 scans the sample by moving the at least one second electro-magnetic radiation across the sample.

23. The apparatus according to paragraph 21, wherein the at least one fifth arrangement includes a fiber optic arrangement.

24. An apparatus comprising:

at least one first arrangement configured to receive at least one first electro-  
5 magnetic radiation and at least one second electro-magnetic radiation provided from a sample, wherein the first and second electro-magnetic radiations which are based on at least one third electro-magnetic radiation forwarded to the sample, wherein the at least one first electro-  
magnetic radiation has a first frequency, the at least one second electro-magnetic radiation has a second frequency and the at least one third electro-magnetic radiation has a third  
10 frequency which is different from the first frequency, wherein a difference between the first and third frequencies is based on an acoustic wave inside the sample related to at least one characteristic of the sample, wherein the at least one first arrangement is further configured to separate the first and second electro-magnetic radiations into first and second respective frequency component radiations; and

15 at least one second arrangement configured to simultaneously detect the first and second frequency component radiations, and generate information associated with the sample based on the first and second frequency component radiations.

25. The apparatus according to paragraph 24, wherein the at least one second electro-magnetic radiation is based on at least one of an elastic scattering, a vibrational Raman  
20 scattering or a fluorescence within the sample.

26. The apparatus according to paragraph 24, wherein the difference between the at least one first frequency and the at least one third frequency is greater than 10 THz.

27. The apparatus according to paragraph 24, further comprising at least one third arrangement configured to image the at least one portion of the sample based on the information.

28. The apparatus according to paragraph 24, wherein the at least one first arrangement  
5 includes a narrow band spectral separating arrangement for separating the at least one first electro-magnetic radiation, and a broadband spectral separating arrangement for separating the at least one second electro-magnetic radiation.

29. A method comprising:

receiving at least one first electro-magnetic radiation provided from a sample  
10 which is based on at least one second electro-magnetic radiation forwarded to the sample, wherein the at least one first electro-magnetic radiation has a first frequency and the at least one second electro-magnetic radiation has a second frequency which is different from the first frequency, and wherein a difference between the first and second frequencies is based on an acoustic wave inside the sample related to at least one characteristic of the sample;

15 receiving at least one third electro-magnetic radiation which is based on the at least one first electro-magnetic radiation and separate the at least one third electro-magnetic radiation into a particular finite number (N) of frequency component radiations;

receiving a particular energy of more than  $1/N$  of energy of the at least one third electro-magnetic radiation; and

20 generating information associated with the sample.

30. A method comprising:

receiving at least one first electro-magnetic radiation and at least one second electro-magnetic radiation provided from a sample, wherein the first and second electro-magnetic radiations which are based on at least one third electro-magnetic radiation



forwarded to the sample, wherein the at least one first electro-magnetic radiation has a first frequency, the at least one second electro-magnetic radiation has a second frequency and the at least one third electro-magnetic radiation has a third frequency which is different from the first frequency, and wherein a difference between the first and third frequencies is based on an

5 acoustic wave inside the sample related to at least one characteristic of the sample;

separating the first and second electro-magnetic radiations into first and second respective frequency component radiations; and

simultaneously detecting the first and second frequency component radiations, and generate information associated with the sample based on the first and second frequency

10 component radiations.

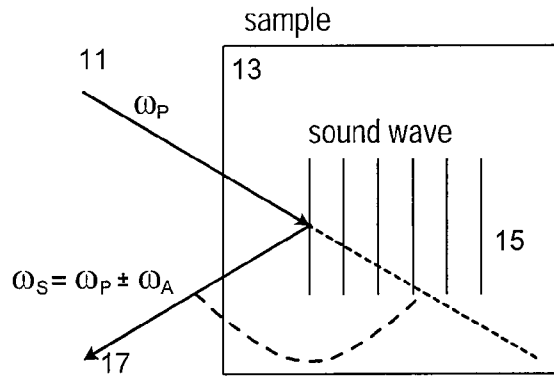

FIG. 1

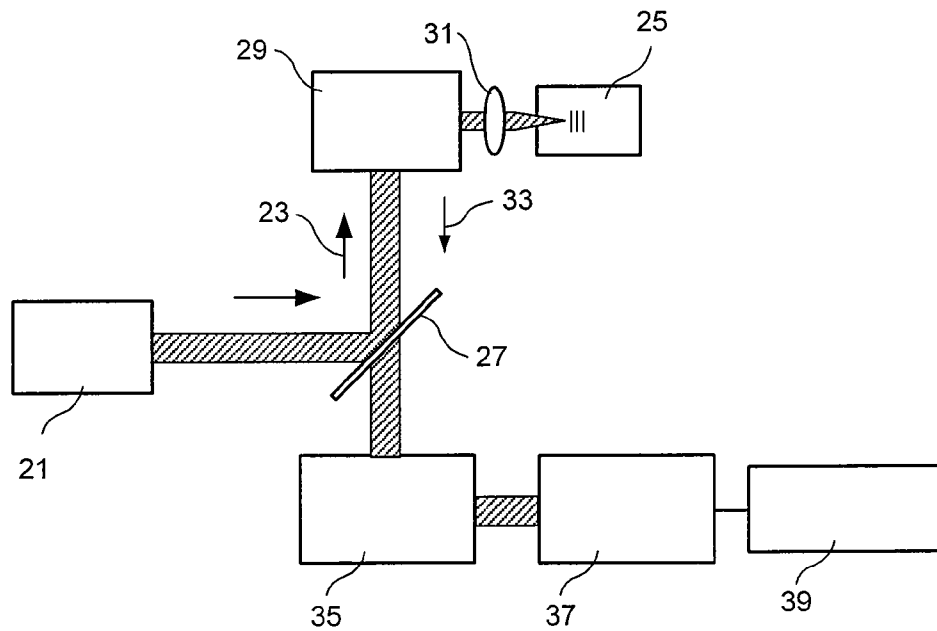

FIG. 2

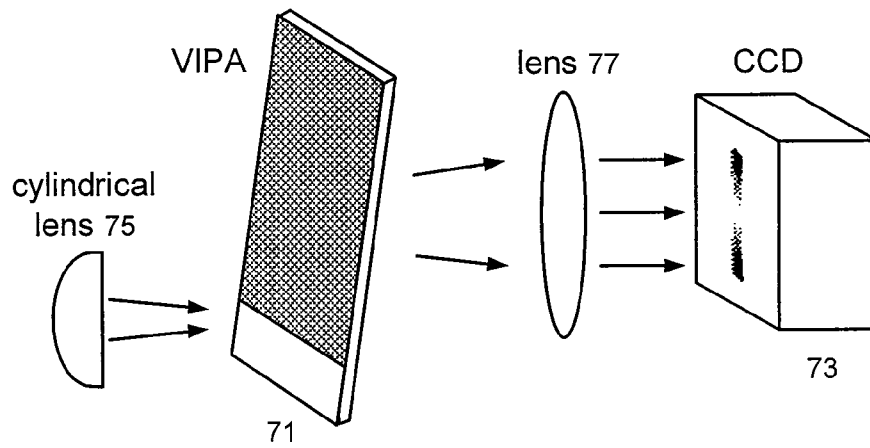
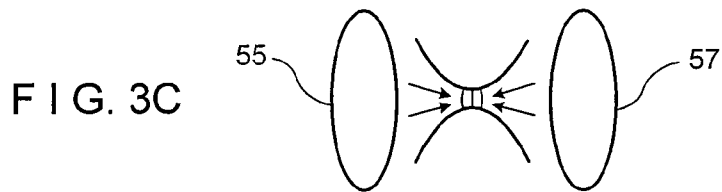
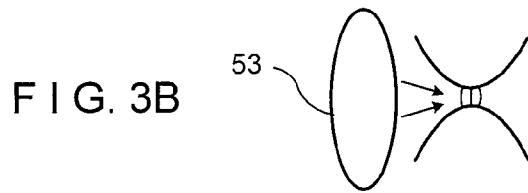
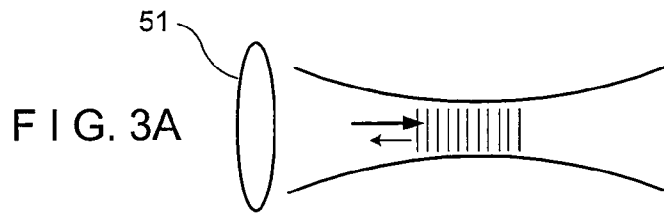

FIG. 4

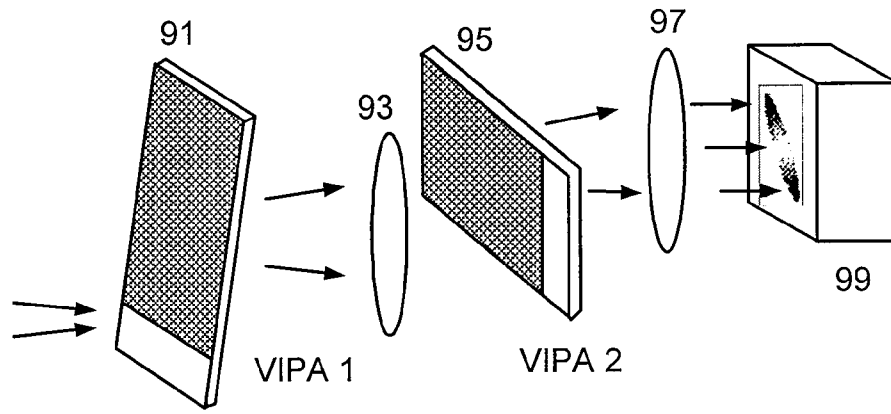

FIG. 5

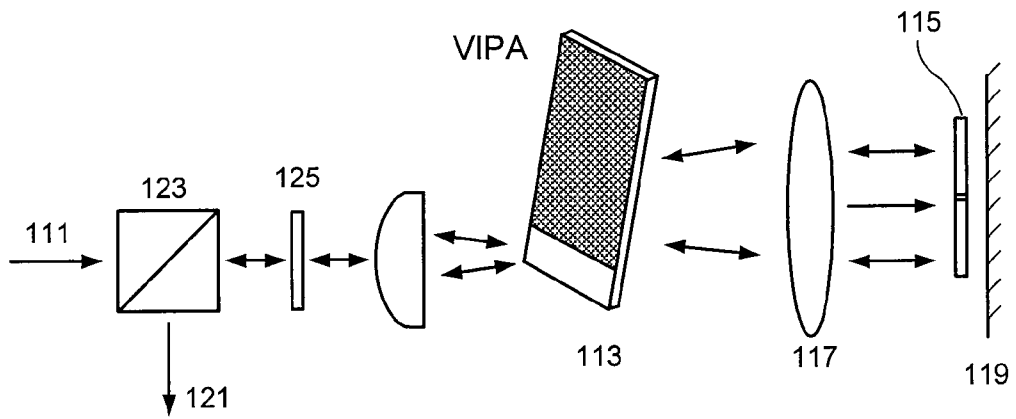

FIG. 6

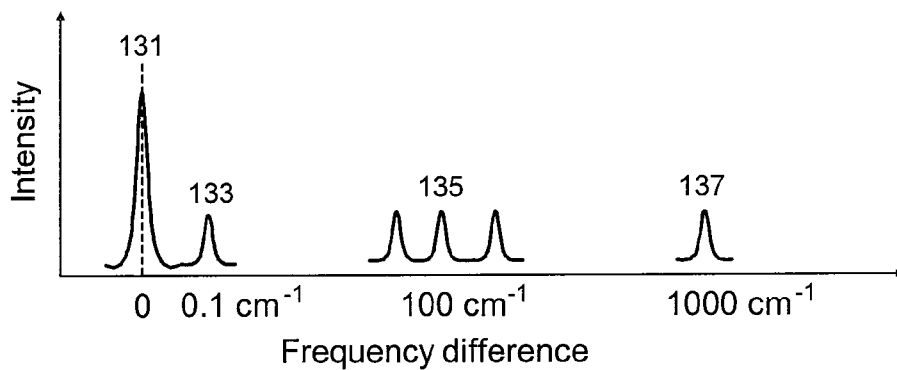

FIG. 7

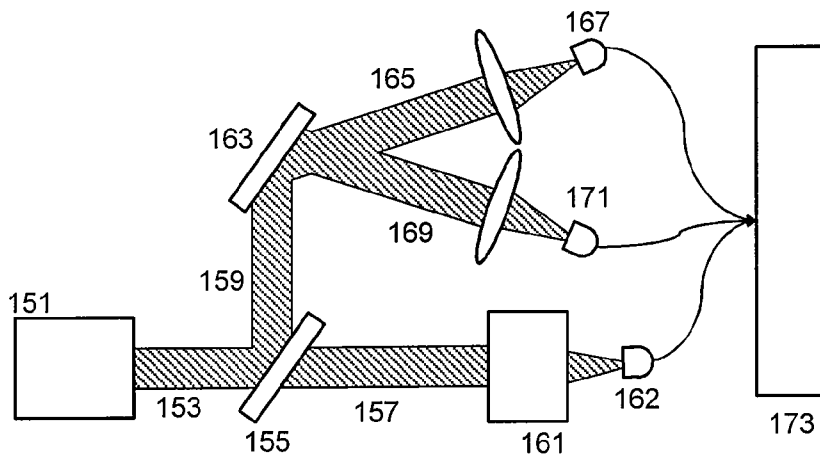
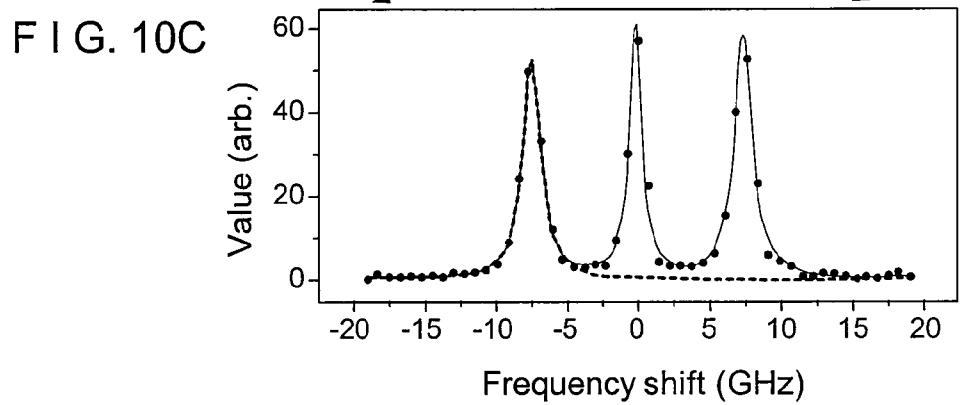
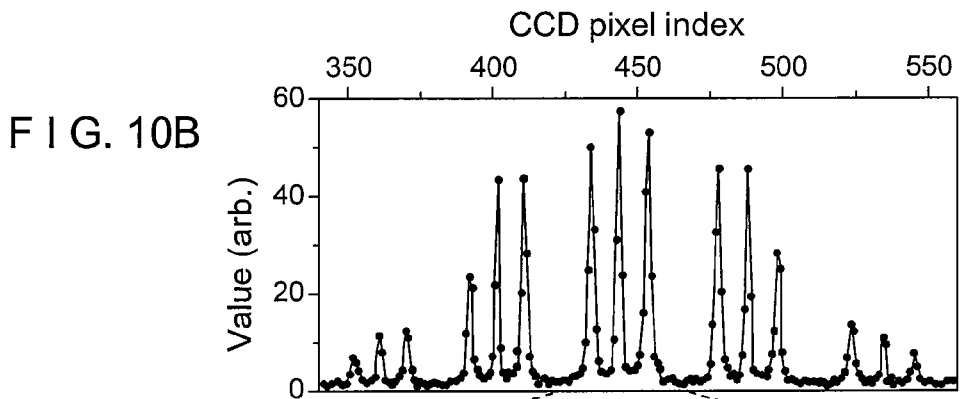
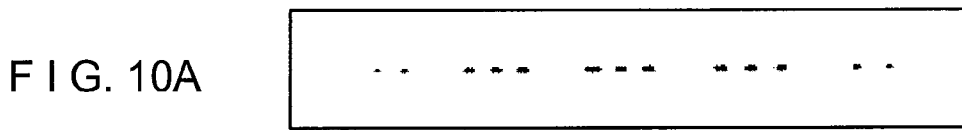
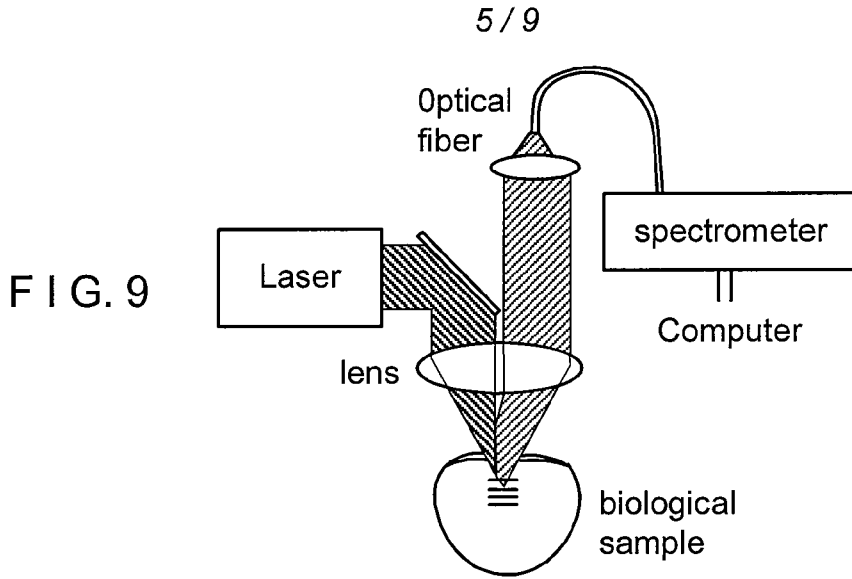

FIG. 8

5 / 9



6 / 9

FIG. 11

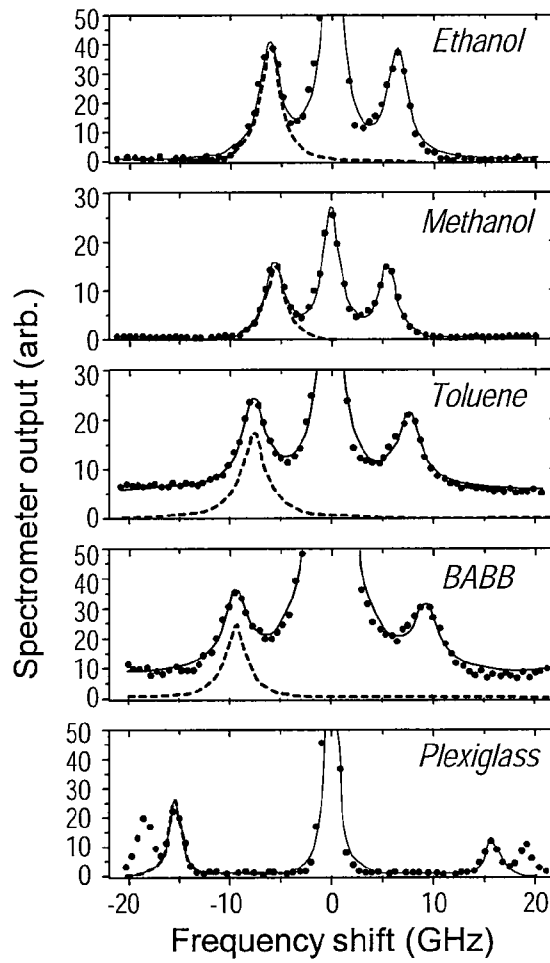
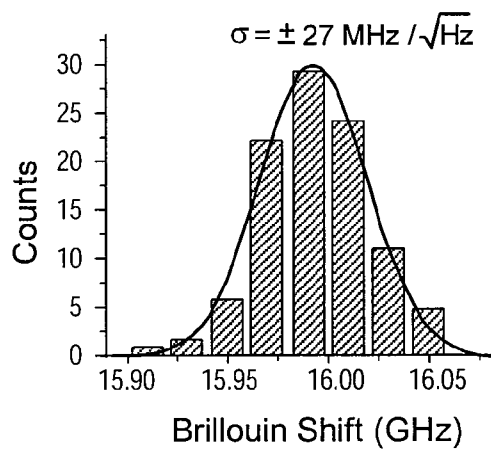

FIG. 12



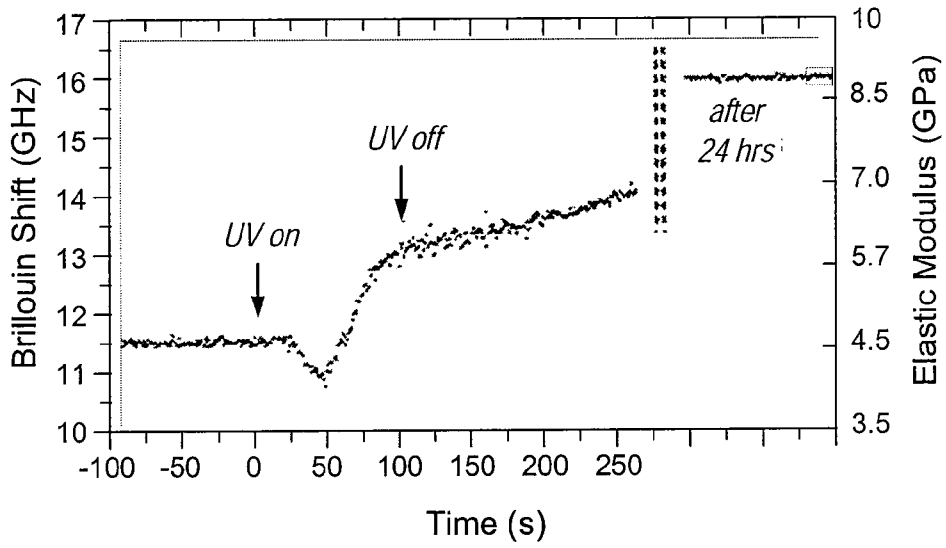

FIG. 13

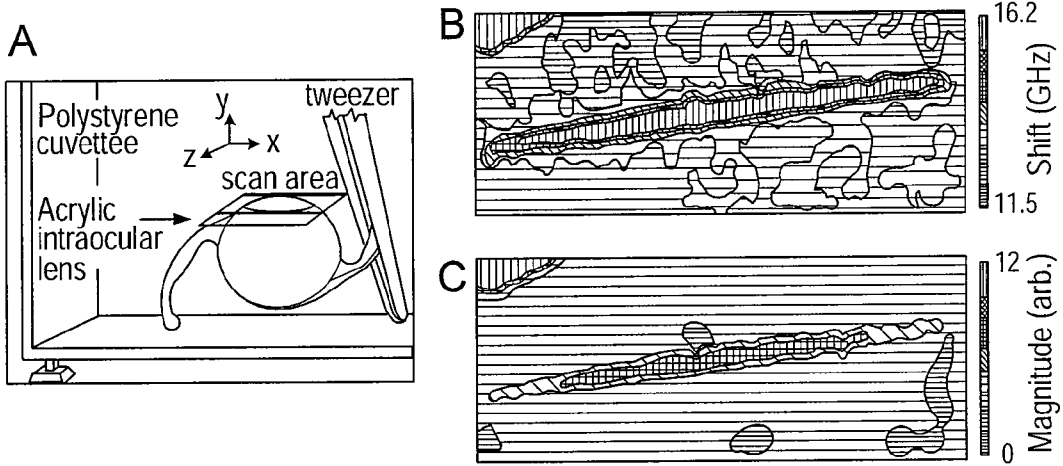

FIG. 14



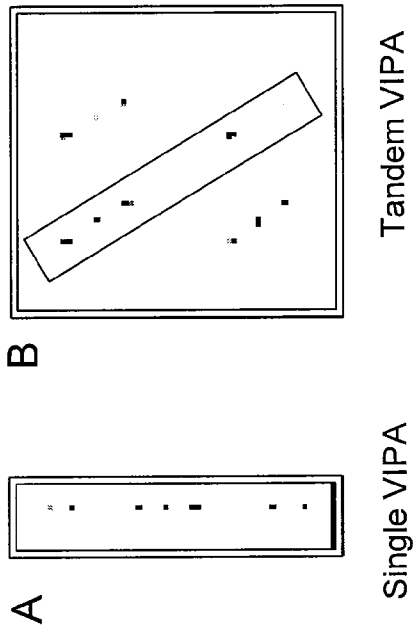

FIG. 15

8/9

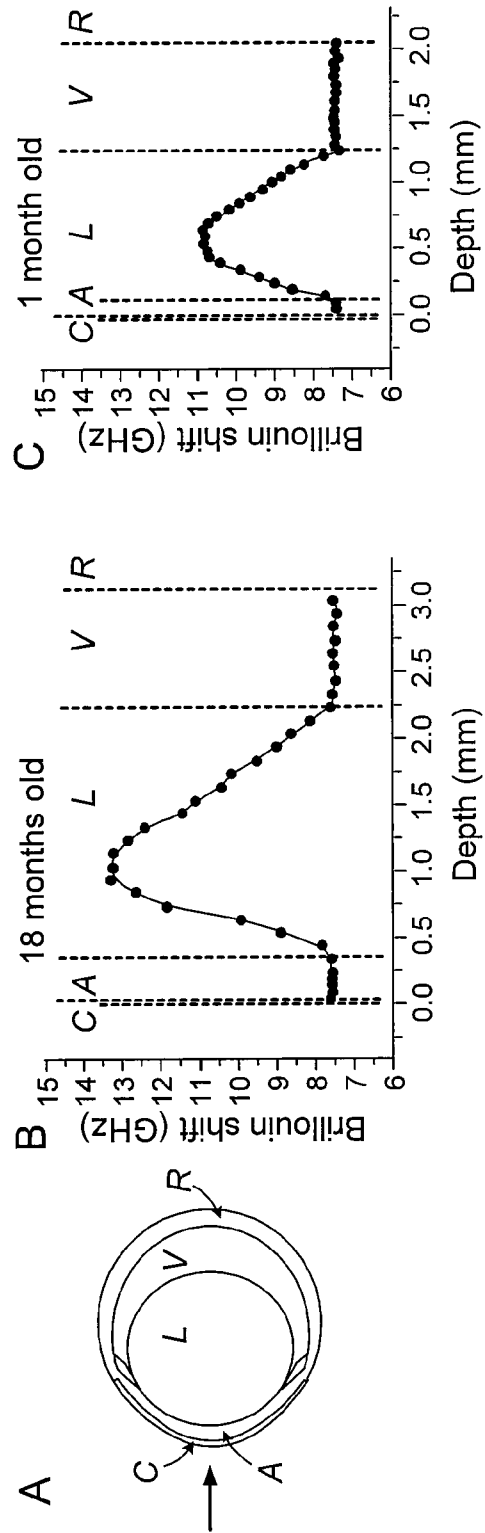

FIG. 16

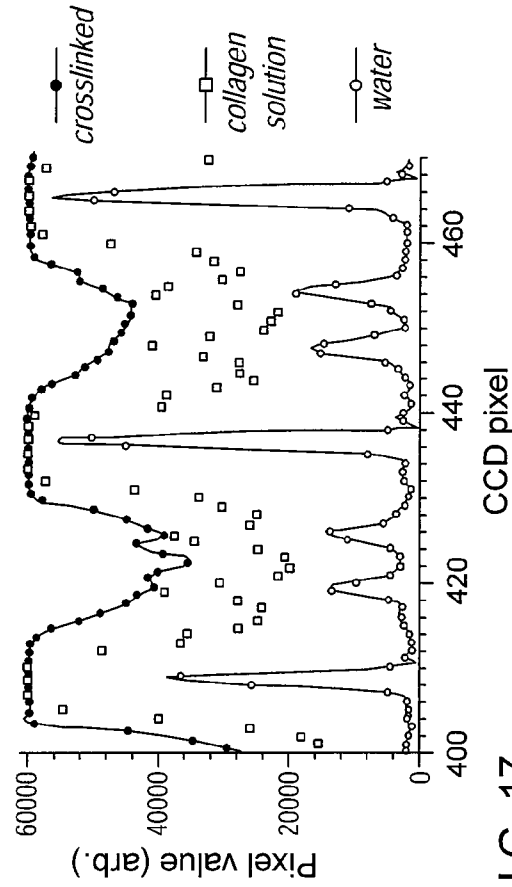

FIG. 17

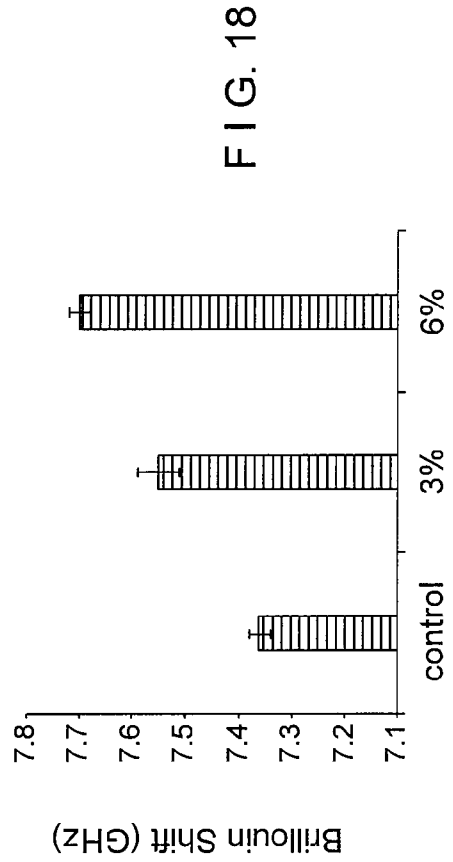
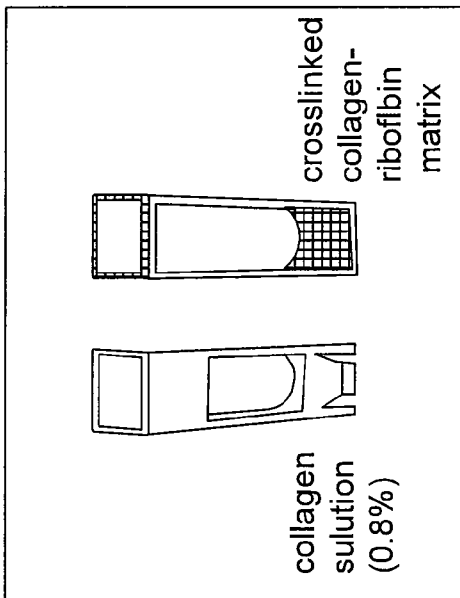

FIG. 18