

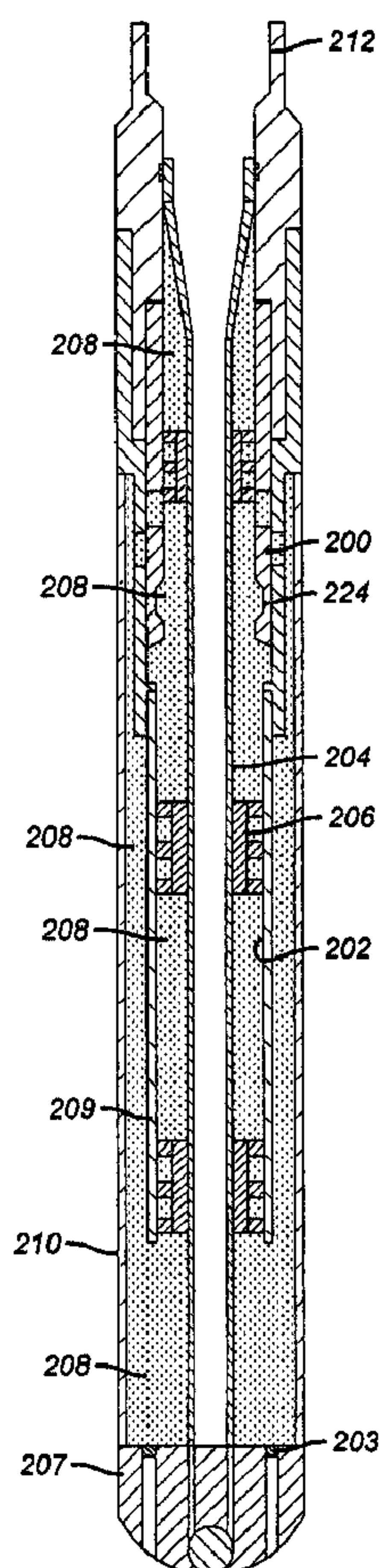

(86) Date de dépôt PCT/PCT Filing Date: 2006/02/09
 (87) Date publication PCT/PCT Publication Date: 2006/08/17
 (45) Date de délivrance/Issue Date: 2011/04/26
 (85) Entrée phase nationale/National Entry: 2007/08/13
 (86) N° demande PCT/PCT Application No.: US 2006/004648
 (87) N° publication PCT/PCT Publication No.: 2006/086591
 (30) Priorités/Priorities: 2005/02/11 (US60/652,374);
 2006/02/07 (US NONE); 2006/02/07 (US NONE);
 2006/02/07 (US NONE)

(51) Cl.Int./Int.Cl. *E21B 43/10* (2006.01),
E21B 33/14 (2006.01), *E21B 34/14* (2006.01)
 (72) Inventeurs/Inventors:
 ADAM, MARK K., US;
 CARMODY, MICHAEL A., US;
 JABS, MATTHEW JAY, US;
 O'BRIEN, ROBERT, US;
 JIRAL, DENNIS G., US;
 PAYNE, HAROLD E., US
 (73) Propriétaire/Owner:
 BAKER HUGHES INCORPORATED, US
 (74) Agent: SIM & MCBURNEY

(54) Titre : PROCEDE ET SYSTEME DE GARNITURE MONOTROU EXPANSIBLE COLLEE A COURSE SIMPLE
 (54) Title: ONE TRIP CEMENTED EXPANDABLE MONOBORE LINER SYSTEM AND METHOD



(57) Abrégé/Abstract:

An apparatus to protect the mounting area (202) of casing and a locating profile (209) and optionally a sliding sleeve valve (200) and a flow path from the outside of the valve to the annulus when subsequent attachment of an expanded liner (218) is intended

(57) **Abrégé(suite)/Abstract(continued):**

and the expanded liner is to be cemented in place. A barrier sleeve (204), nose (207), and outer sleeve (210) define a sealed cavity having a loose incompressible material (208) inside that covers the mounting location on the casing. A locating profile and an optional sliding sleeve valve and a flow path from the outside of the valve to the annulus can be provided. The cementing of the casing takes place through the barrier sleeve. After the cementing, the sleeve and nose are drilled out and the incompressible material is removed to the surface with the drill cuttings.

(12) INTERNATIONAL APPLICATION PUBLISHED UNDER THE PATENT COOPERATION TREATY (PCT)

(19) World Intellectual Property Organization
International Bureau(43) International Publication Date
17 August 2006 (17.08.2006)

PCT

(10) International Publication Number
WO 2006/086591 A1

(51) International Patent Classification:

E21B 43/10 (2006.01) *E21B 34/14* (2006.01)
E21B 33/14 (2006.01)

(21) International Application Number:

PCT/US2006/004648

(22) International Filing Date: 9 February 2006 (09.02.2006)

(25) Filing Language: English

(26) Publication Language: English

(30) Priority Data:

60/652,374	11 February 2005 (11.02.2005)	US
Not furnished	7 February 2006 (07.02.2006)	US
Not furnished	7 February 2006 (07.02.2006)	US
Not furnished	7 February 2006 (07.02.2006)	US

(71) Applicant (for all designated States except US): **BAKER HUGHES INCORPORATED** [US/US]; Suite 1200, 3900 Essex Lane, Houston, Texas 77027 (US).

(71) Applicants and

(72) Inventors: **ADAM, Mark, K.** [US/US]; 1036 Algregs, Houston, Texas 77009 (US). **CARMODY, Michael, A.** [US/US]; 1906 Wagon Gap Trail, Houston, Texas 77090 (US). **JABS, Matthew, Jay** [US/US]; 6969 Hollister #1617, Houston, Texas 77040 (US). **O'BRIEN, Robert** [US/US]; 23226 Hazel Field, Katy, Texas 77494 (US). **JIRAL, Dennis, G.** [US/US]; 2830 Manor Ridge Court, Katy, Texas 77494 (US). **PAYNE, Harold, E.** [US/US]; 705 Clayton, Tomball, Texas 77375 (US).

(74) Agents: **RIDDLE, J., Albert** et al.; Baker Hughes Incorporated, Suite 1200, 3900 Essex Lane, Houston, Texas 77027 (US).

(81) Designated States (unless otherwise indicated, for every kind of national protection available): AE, AG, AL, AM, AT, AU, AZ, BA, BB, BG, BR, BW, BY, BZ, CA, CH, CN, CO, CR, CU, CZ, DE, DK, DM, DZ, EC, EE, EG, ES, FI, GB, GD, GE, GH, GM, HR, HU, ID, IL, IN, IS, JP, KE, KG, KM, KN, KP, KR, KZ, LC, LK, LR, LS, LT, LU, LV, LY, MA, MD, MG, MK, MN, MW, MX, MZ, NA, NG, NI,

[Continued on next page]

(54) Title: ONE TRIP CEMENTED EXPANDABLE MONOBORE LINER SYSTEM AND METHOD

(57) Abstract: An apparatus to protect the mounting area (202) of casing and a locating profile (209) and optionally a sliding sleeve valve (200) and a flow path from the outside of the valve to the annulus when subsequent attachment of an expanded liner (218) is intended and the expanded liner is to be cemented in place. A barrier sleeve (204), nose (207), and outer sleeve (210) define a sealed cavity having a loose incompressible material (208) inside that covers the mounting location on the casing. A locating profile and an optional sliding sleeve valve and a flow path from the outside of the valve to the annulus can be provided. The cementing of the casing takes place through the barrier sleeve. After the cementing, the sleeve and nose are drilled out and the incompressible material is removed to the surface with the drill cuttings.

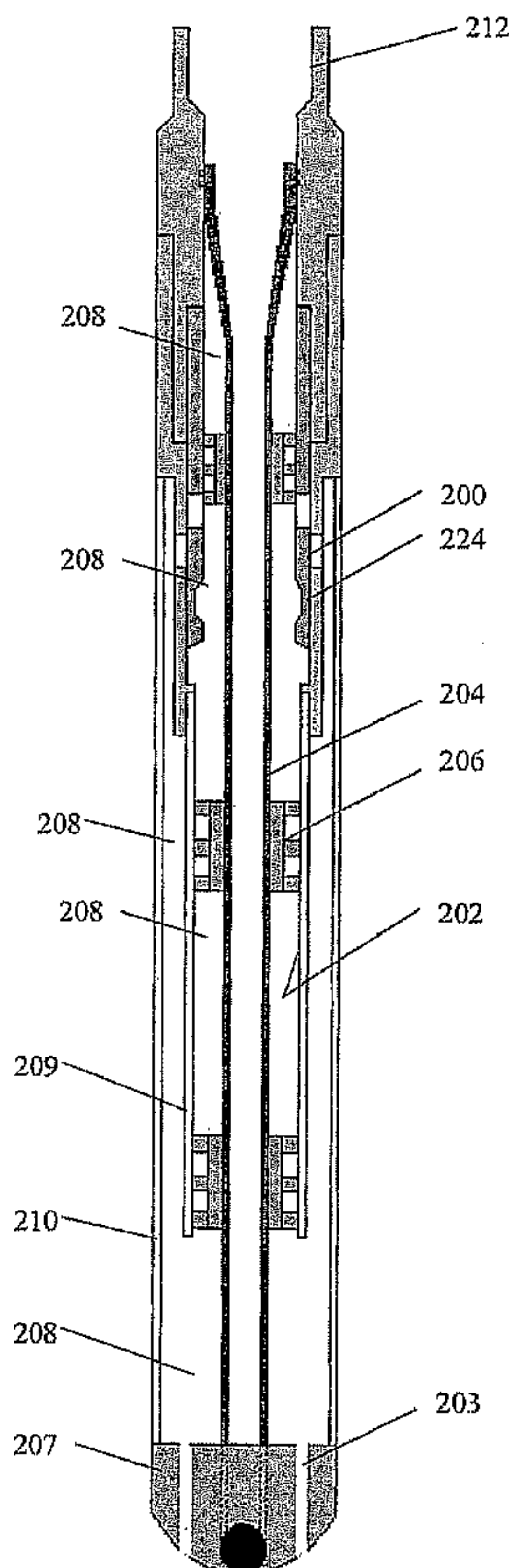

WO 2006/086591 A1

WO 2006/086591 A1

NO, NZ, OM, PG, PH, PL, PT, RO, RU, SC, SD, SE, SG, SK, SL, SM, SY, TJ, TM, TN, TR, TT, TZ, UA, UG, US, UZ, VC, VN, YU, ZA, ZM, ZW.

(84) Designated States (*unless otherwise indicated, for every kind of regional protection available*): ARIPO (BW, GH, GM, KE, LS, MW, MZ, NA, SD, SL, SZ, TZ, UG, ZM, ZW), Eurasian (AM, AZ, BY, KG, KZ, MD, RU, TJ, TM), European (AT, BE, BG, CH, CY, CZ, DE, DK, EE, ES, FI, FR, GB, GR, HU, IE, IS, IT, LT, LU, LV, MC, NL, PL, PT,

RO, SE, SI, SK, TR), OAPI (BF, BJ, CF, CG, CI, CM, GA, GN, GQ, GW, ML, MR, NE, SN, TD, TG).

Published:

- *with international search report*
- *before the expiration of the time limit for amending the claims and to be republished in the event of receipt of amendments*

For two-letter codes and other abbreviations, refer to the "Guidance Notes on Codes and Abbreviations" appearing at the beginning of each regular issue of the PCT Gazette.

**ONE TRIP CEMENTED EXPANDABLE MONOBORE LINER SYSTEM AND
METHOD**

FIELD OF THE INVENTION

[0002] The field of this invention is the method of running a tubular inside casing and securing it and more particularly to techniques for protecting the mounting location for the tubular on the casing as the casing is cemented and thereafter cementing the liner after it is expanded into the mounting location.

BACKGROUND OF THE INVENTION

[0003] Figure 1 is illustrative of the prior techniques of running in casing with a casing shoe 16 near its lower end. If later a tubular is run in and needs to be attached to the casing by expansion, the presence of cement debris in the support area on the casing where the tubular will be attached could prevent a sealed connection from being obtained. One way around that would be to deliver the cement into a shoe mounted below the point at which the liner will be attached later. Another method would be to run brushes and scrapers into the mounting location after cementing to be sure it was clean so that a good seal and support for the tubular subsequently installed can be obtained. However these techniques require significant amounts of time and create an associated cost.

[0004] The present invention protects the mounting location on the casing during cementing with a barrier sleeve that covers a recess. The barrier sleeve defines a sealed annular space that contains an incompressible material. This allows the barrier sleeve to be compliant to changes in hydrostatic pressure as the casing is lowered into place.

Cementing is done through the barrier sleeve. The barrier sleeve is subsequently drilled out exposing a recess and a locating profile and optionally a sliding sleeve valve. The tubular can then be positioned accurately using the locating profile and a collet mechanism on the expansion tool and expanded in to sealing contact with the casing. Due to the recess, the drift diameter of the tubular after expansion into the recess is at least as large as the casing drift diameter. The entire tubular can be expanded to its lower end and a run in shoe at the lower end of the tubular can be retrieved and removed from the well with the swaging assembly and the running string that delivered it. The sliding sleeve in the casing shoe can be selectively opened and closed with a shifting tool run on the expansion string above the expansion tools, running tool, and the liner to be expanded. Another option is for this sliding sleeve to be located in the liner to be expanded below the upper portion that mounts in the above casing. The port opened and closed by this sliding sleeve can be used to either pump cement into the annulus or to return the wellbore fluid displaced by cement from the annulus into the casing string. When the sliding sleeve is in the casing shoe, to allow for fluid flow between the outside of this port and the annulus below the shoe after the shoe has been cemented with the string to which it is attached an additional outer sleeve is run on the outside of the recess sleeve. This outer sleeve is connected at its lower end to the inner barrier sleeve via a guide nose. The flow path between the outside of the ports and the annulus is opened when the nose is drilled out and under reamed. A cement retainer device is to be located at the bottom of the string preventing cement pumped into the annulus from entering into the expanded liner due to density differences. This retainer device can be the location from which cement is pumped into the annulus or where the wellbore fluid displaced by the cement is returned from the annulus to the inside of the casing string. The cement retainer can be drilled out in a subsequent trip into the hole. These advantages and others of the present invention will be readily appreciated by those skilled in the art from a review of the description of the preferred embodiment and the claims that appear below.

SUMMARY OF THE INVENTION

[0005] An apparatus to protect the mounting area of casing and a locating profile and optionally a sliding sleeve valve and a flow path from the outside of the valve to the

annulus when subsequent attachment of an expanded liner is intended and the expanded liner is to be cemented in place. A barrier sleeve, nose, and outer sleeve define a sealed cavity having a loose incompressible material inside that covers the mounting location on the casing. A locating profile and an optional sliding sleeve valve and a flow path from the outside of the valve to the annulus can be provided. The cementing of the casing takes place through the barrier sleeve. After the cementing, the sleeve and nose are drilled out and the incompressible material is removed to the surface with the drill cuttings. A liner is inserted in the casing and is preferably expanded into sealing contact with the mounting location on the casing. After expansion a cement retainer positioned at the bottom of the expanded liner and the sliding sleeve located either above the mounting location of the liner in the casing shoe or in the liner below the mounted top section allow cement to be delivered outside the expanded liner and the displaced wellbore fluid to return into the casing through so that the liner can be cemented. The cement retainer can be delivered with either the liner or the expansion tools to allow expansion and cementing in a single trip. A shifting tool can be run on the expansion string to actuate the sliding sleeve and if necessary to allow for cement to be pumped from the drill string into the annulus through the sliding sleeve. The cement retainer can be milled out in a separate trip.

[0005a] According to one aspect of the present invention there is provided a completion method comprising:

- running in a tubular to be expanded into a wellbore with a run in shoe adjacent a lower end thereof for attachment to an existing tubular;
- expanding the tubular with a swage assembly;
- engaging the run in shoe with said swage assembly;
- finishing expansion to said lower end by advancing the now engaged run in shoe beyond said lower end;
- providing a valve in the wall of the tubular to be expanded;
- expanding said valve when the tubular is expanded;
- operating said valve after it is expanded; and
- removing the run in shoe through the now expanded tubular.

[0005b] According to yet another aspect of the present invention there is provided a completion method, comprising:

running in a tubular to be expanded into a wellbore with a run in shoe adjacent a lower end thereof for attachment to an existing tubular;
expanding the tubular with a swage assembly;
engaging the run in shoe with said swage assembly; and
removing the run in shoe through the now expanded tubular;
providing a valve in said existing tubular; and
operating said valve with said swage assembly.

DETAILED DESCRIPTION OF THE DRAWINGS

[0006] Figure 1 is a prior art production casing illustrating a standard casing shoe at the lower end;

[0007] Figure 2 shows a production string with the shoe track of the present invention;

[0008] Figure 3 shows the production casing with the shoe track of the present invention run into the wellbore;

[0009] Figure 4 is the view of Figure 3, after cementing;

[0010] Figure 5 is the view of Figure 4 showing the shoe track exposed after drillout and the wellbore extended below the production casing;

[0011] Figure 6 is the view of Figure 5 showing the reaming of the extension bore just drilled;

[0012] Figure 7 is a close up view of the now exposed shoe;

[0013] Figure 8 shows the liner run in on a running tool and in position to be expanded;

[0014] Figure 9 is the view of Figure 8 indicating the initial stroking of the swage, which results in release from the running tool;

[0015] Figure 10 is the view of Figure 9 showing the anchor released and weight being set down to reposition for the next stroke of the swage;

[0016] Figure 11 is the view of Figure 10 showing the next stroke of the swage;

[0017] Figure 12 is the view of Figure 11 showing the swage advancing toward the lower end of the liner;

[0018] Figure 13 is the view of Figure 12 with the swage now engaging the running shoe of the liner at its lower end;

[0019] Figure 14 is the view of Figure 13 with the liner fully expanded and the swage being removed with the running shoe by withdrawing the running tool from the fully expanded liner;

[0020] Figure 15 is a close up view of the sleeve protecting the recessed shoe during cementing;

[0021] Figures 16a-16b show the capture of the guide nose assembly;

[0022] Figures 17a-17b show the shearing out of the guide nose assembly from the tubular or liner;

[0023] Figures 18a-18b show the guide nose fully released and captured;

[0024] Figures 19a-19b show the emergency release feature;

[0025] Figure 20 shows a casing shoe in its run in configuration with locating profile, sliding sleeve valve closed over a port, recessed expanded liner mounting location, barrier sleeve, guide nose and outer sleeve;

[0026] Figure 21A is a view of the casing shoe in Figure 20 as it is being drilled and under reamed with the valve closed;

[0027] Figure 21B is a view of the casing shoe in Figure 20 after it has been drilled and under reamed with the valve closed;

[0028] Figure 22 shows a liner expanded in place;

[0029] Figure 23 shows expansion of a liner with a swage;

[0030] Figure 24 is the view of Figure 23 showing the removal of the swage and guide nose;

[0031] Figure 25 shows a separate run to insert the cement retainer for cementing;

[0032] Figure 26 is the view of Figure 25 showing the cement retainer set in place and disengaged by its running tool, while the shifting tool is opening the sliding sleeve valve;

[0033] Figure 27 shows cement being pumped into the annulus through the drill string and cement retainer and the displaced wellbore fluid being returned through the sliding sleeve valve into the casing;

[0034] Figure 28 shows the sliding sleeve valve being shut by the shifting tool as the drill string is pulled from the well;

[0035] Figure 29 shows a drill string milling away the cement retainer before it continues on to drill the next section;

[0036] Figure 30 shows a closable aperture for use in cementing located in the portion of the liner to be expanded;

[0037] Figure 31 shows a cementing shoe delivered with the liner before expansion and the swage initiates expansion;

[0038] Figure 32 shows the expansion of Figure 31 complete and the cementing shoe tagged into by the bottom hole assembly;

[0039] Figure 33 is the view of Figure 32 with cement delivered down the string and through the cementing shoe;

[0040] Figure 34 is the view of Figure 33 after cementing and removal of the bottom hole assembly leaving the cementing shoe in place;

[0041] Figure 35 is the view of Figure 34 showing the cementing shoe being milled out;

[0042] Figure 36 shows an alternative to Figure 31 delivering the cement retainer at the bottom of the swage assembly used for expanding;

[0043] Figure 37 is an alternative to Figure 36 where the shoe is delivered with the swage assembly;

[0044] Figure 38 shows cementing by delivering into the top of the annulus of the expanded liner and taking well fluid returns through the shoe;

[0045] Figure 39 shows removal of the swage assembly from the shoe after the cement is delivered to hold the cement in place;

[0046] Figure 40 shows the shoe being drilled or milled out after the cementing is concluded;

[0047] Figure 41 show an expandable tubular run in with a cementing isolation device near the lower end of the string and inside it;

[0048] Figure 42 is the view of Figure 41 with the cementing isolation device outside the tubular;

[0049] Figure 43 shows the expansion nearly complete;

[0050] Figure 44 shows the expansion system engaging the isolation device and moving down to conclude the expansion;

[0051] Figure 45 shows the cementing device repositioned in the tubular and ready for cementing;

[0052] Figure 46 shows cementing through the expansion assembly and the cementing device; and

[0053] Figure 47 shows the cementing device milled out after cementing.

DETAILED DESCRIPTION OF THE PREFERRED EMBODIMENT

[0054] Figure 1 illustrates a casing string **10** having a known landing collar **12** and a standard float collar **14** as well as a casing shoe **16** adjacent its lower end **18**. Typically, in the past, the cement is pumped through the casing shoe **16** and then a dart or wiper is used to displace cement from the casing **10** and out through the shoe **16** and into the surrounding annulus. When the well is to be drilled deeper, the shoe **16** is drilled out but residual cement could still be present. The presence of such cement or shoe debris after drilling can affect the seal that is subsequently needed when a liner is inserted and secured to the casing **10**. This is particularly a concern when the liner is to be expanded to secure it to a recessed mounting location at the bottom of the casing **10**.

[0055] The present invention addresses this concern with a barrier sleeve **20** shown in Figures 2 and 15. As shown in Figure 15, the casing string **22** has a lower section **24**. Inside section **24** is a barrier sleeve **20** mounted and defining an annular space **28** that contains an incompressible material **30**. Preferably the incompressible material **30** is loosely mounted sand but other materials can be used. The purpose of the material **30** is to control the burst of barrier sleeve **20** and the collapse of recessed mounting location **24** in response to increasing hydrostatic pressures as the depth of the casing **22** increases, when it is lowered into initial position. Sleeve **20** is preferably fiberglass sealed at ends **32** and **34**. Sleeve **20** initially covers locating profile **36** and recessed mounting location

38, which will later serve as the location for securing a tubular such as a liner by a variety of methods. The preferred method of expansion will be described in more detail below. Sleeve 20 is preferably a material that can be quickly drilled such as plastics or composites, to mention a few. During cementing of the casing 22, the sleeve 20 has an inner surface 40, which is contacted by the cement. Ultimately a dart or wiper plug 42 passes through casing 22 and lands on landing collar 12 (see Figures 3 & 4) to displace most of the cement out of the casing 22 and into the surrounding annulus. The sleeve 20 is subsequently drilled out allowing the incompressible material 30 to escape and exposing the clean locating profile 36 and recessed mounting location 38 for subsequent attachment of a tubular as will be described below. The drilling removes all of seal rings 42 and 46 without damaging the casing 22 or recess sleeve 24.

[0056] The method can be understood by beginning at Figure 3, where the casing 22 is mounted in the desired position for cementing in the wellbore 26. The assembly includes landing collar 12 and float collar 14. The assembly shown in Figure 15 is at the lower end of the assembly, but for clarity only the barrier sleeve 20 is referenced in the schematic illustration.

[0057] Figure 4 shows that cement 48 has been displaced by plug 42 landing on landing collar 12. As a result, cement 48 is pushed through sleeve 20, through run in shoe 50 and into annulus 52.

[0058] In Figure 5, a drill string 54 with a bit assembly 56 has been advanced through the casing 22 and has milled out the wiper 42 and the sleeve 20 to expose locating recess 36 and long recess 38. The incompressible material 30 is released and circulated to the surface with the drill cuttings from the action of bit assembly 56.

[0059] Figure 6 illustrates the enlarging of the new section of wellbore 58 to a new dimension 60 using an under-reamer or an RWD bit 62. Depending on the nature of the bit assembly 56, the wellbore 60 can be created in a single trip in the hole or in multiple trips. Figure 7 shows the drilling of wellbore 60 complete and the drill string 54 and bit assembly 56 removed from the wellbore 60 and stored at the surface.

[0060] Figure 8 shows a running string 64 that supports a liner or other tubular 66 at locking dogs 68. The assembly further comprises an anchor 70 with slips 72 that are preferably pressure sensitive to extend slips 72 and allow them to retract when pressure is removed. Also in the assembly is a piston and cylinder combination 74 that drives a swage 76, in response to pressure applied to the piston and cylinder combination 74. Initially, as illustrated in Figure 9, pressure is applied to extend the slips 72 and drive down the swage 76 as illustrated schematically by arrows 78. The upper end or expandable liner hanger 80 of the tubular 66 is expanded into recessed mounting location 38 for support from casing 22. The swage 76 is then stroked enough to suspend the tubular 66 to casing 22. As illustrated in Figure 10, when weight is set down at the surface, after internal pressure is removed, the slips 72 have been released and the piston and cylinder combination 74 is re-cocked for another stroke for swage 76. The dogs 68 become undermined and release their grip on tubular 66 as the piston and cylinder combination is re-cocked. Figure 11 shows the subsequent stroking, further expanding the tubular 66. Optionally, one or more open hole packers 82 can be used to ultimately make sealing contact in wellbore 60 after expansion.

[0061] Figure 12 illustrates the continuation of the movement of the swage in response to applied surface pressure to anchor 70 and piston and cylinder combination 72. Those skilled in the art will appreciate that force magnification can be incorporated into piston and cylinder combination 72 and it is possible for a greater force can be applied to swage 76 at the beginning of each stroke as compared to the balance of each stroke. These features are disclosed in U.S. Patent No. 7,222,669 to Sonnier issued on May 29, 2007. However, other techniques can be used for swaging or even to secure the tubular 66 to long recess 38 or another location initially covered by a sleeve such as 20 during cementing of the casing 22, without departing from the invention.

[0062] Eventually in Figure 13, the running string 64 expands the open hole packers 82 into sealing contact with the wellbore 60 as it approaches the run in shoe 84 mounted near the lower end 86 of tubular 66. A grasping mechanism 88 is shown

schematically at the lower end of the expansion string 64. Contact is made and the run in shoe 84 is released and grabbed by mechanism 88. Swage 76 expands lower end 86 of tubular 66 enough so that the run in shoe can be retrieved through it. When the string 64 is removed from the wellbore 60 and to the surface, it takes with it the anchor 70, the piston and cylinder combination 74 and the run in shoe 84, leaving a large opening 90 in the lower end of tubular 66, as shown in Figure 14. Those skilled in the art will appreciate that the run in shoe 84 facilitates insertion of the tubular 66 by presenting a guide nose as the tubular is initially advanced into position, as shown in Figure 8. Optionally, it has a valve in it to check upward flow and allow downward circulation to facilitate insertion of the tubular 66. Removal of the run in shoe 84 as described above presents a large opening in the lower end of the tubular 66 to facilitate subsequent drilling operations or other completion techniques.

[0063] Figures 16-19 show the grasping mechanism 88 in greater detail. It has a top sub 100 connected at thread 102 below dogs 68. Top sub 100 is connected to mandrel 104 at thread 106. The run in shoe 84 is attached to tubular 66 by virtue of ring 108 held against rotation by pin 110, which extends from shoe 84. Threads 112 on ring 108 engage threads 114 on tubular 66. Ring 116 holds ring 112 in position on shoe 84. Shoe 84 has a groove 118 and a stop surface 120. Top sub 100 has a surface 122 that lands on surface 120 as the grasping mechanism 88 advances with the swage 76. When surface 122 hits surface 120 the tubular 66 has not yet been expanded. Mandrel 104 has a series of gripping collets 124 that land in groove 118 when surfaces 120 and 122 contact. When this happens, as shown in Figure 16a the collets are aligned with recess 126 on mandrel 104 so that they can enter recess 118 in shoe 84. Mandrel 104 has a ring 128 held on by shear pins 130. When a downward force is applied to shoe 84 through the contact between surfaces 120 and 122, threads 112 and 114 shear out and the shoe 84 drops down and is captured on ring 128. At this point, shown in Figure 17a, surface 132 on mandrel 104 supports collets 124 in groove 118. The shoe 84 is now captured to the mandrel 104. As the mandrel 104 moves down in tandem with the swage 76, the tubular 66 is expanded to bottom. Thereafter, the swage 76 and the grasping mechanism 88 and the attached shoe 84 can all be removed to the surface, as shown in Figure 18a. If, for any reason the shoe 84 fails to release from the tubular 66 or gets stuck on the way out to the surface, a pull

on the string **64** shears out pins **130**, allowing the collets **124** to become unsupported as surface **134** is presented opposite recess **118** as shown in Figure 19a. Those skilled in the art will appreciate that other devices can be used to snare the shoe **84** as the swage **76** advances. The ability to remove shoe **84** is advantageous as it removes the need to mill it out and further reduces the risk of the shoe **84** simply turning in response to a milling effort, once it is no longer held against rotation by the now expanded tubular **66**.

[0064] Those skilled in the art will now appreciate the advantages of the above described aspects of the present invention. The sleeve **20** shields a subsequent mounting location for the tubular **66** on casing **22** from contamination with the cement **48** used in the installation of casing **22**. Thus regardless of the method of sealed attachment between the tubular **66** and the casing **22**, there is a greater assurance that the proper sealing support will be obtained without concern that cement may have fouled the mounting location. The assembly including the sleeve **20** is compliant to changes in hydrostatic pressure resulting from advancement of the casing **22** downhole. At the conclusion of expansion or other technique to secure tubular **66** to casing **22**, the lower end of the tubular **66** is left open as the run in shoe **84** is retrieved.

[0065] In certain jurisdictions or with certain operators, just trying to seal around the expanded liner **66** with external packers **82** is not adequate and there is a desire to meet local regulations and provide a monobore completion with the ability to cement the expanded liner. The preferred embodiment of this invention allows such cementing to occur and the expansion and cementing process for the liner to occur in either one or two trip. Comparing the casing shoe of Figure 15 with that of Figure 20 it can be seen that they are the same but the version of Figure 20 has an additional feature of a sliding sleeve valve **200** illustrated in the closed position in Figure 20. The recessed mounting location **202** is covered by a barrier sleeve **204** whose position is maintained with one or more centralizers **206**. An incompressible filler material or fluid **208** initially occupies the volume behind the barrier sleeve **204** and inside the recessed mounting location **202**, the volume between outer sleeve **210** and recess sleeve **209**, and the volume above guide nose **207** and between outer sleeve **210** and barrier sleeve **204**. This continuous volume containing filler material or fluid **208** will be run in without applied pressure. As the

shoe is run in the hole the hydrostatic pressure inside of the barrier sleeve **204**, below the guide nose **207**, and outside of the outer sleeve **210** will increase as collapse pressure on the items defining the volume. Burst disks **203** can be included in the guide nose **207** to allow communication between the volume containing the filler material or fluid **208** and the wellbore the shoe is being run in after a certain differential pressure is reached. This communication equalizes the pressure removing the collapse forces. During equalization wellbore fluid can enter the filler material or fluid volume and coexist with the filler material or volume **208**. For run in the sliding sleeve valve **200** is preferably closed rather than the open position shown in Figure 20 but either position can be used because the space occupied by filler material **208** is isolated so no flow can occur though while the casing attached at connection **212** is being cemented. The cement should not enter through the burst disks **203** as the volume is equalized in pressure and captured from flow. After the casing is cemented, a bit is inserted to drill out the protective assembly of the sleeve **204**, centralizers **206**, and parts of guide nose **207**, as depicted in Figure 21 A. The filler material or fluid **208** is removed to the surface with circulation. The nose and the wellbore below it are then under reamed and the condition depicted in Figure 21 B is achieved. The drilling and under reaming is continued to extend the wellbore to accept the next section of tubular **218**. In Figure 21 B sliding sleeve valve **200** is exposed as is recessed mounting location **202**. Port **214** is closed and arrow **216** indicates no flow through it is possible. Figure 22 shows the next section of tubular **218** in position and expanded into recessed mounting location **202** and beyond. As shown in Figure 23, the assembly to do this expansion can include a combination of an anchor and stoker shown schematically as **220** that is connected to a swage **222** that can be of any number of different designs. As shown in Figure 20, sliding sleeve valve **200** has a groove **224** that is preferably engaged at before expansion of the top of the expanded liner or expandable liner hanger by a collet assembly located on the stoker tool **220** that operates bidirectionally so that on the trip down with the liner **218**, the stoker **220** the collet can provide a confirmation indication of overpull or set down weight that the liner is in the proper location for expansion of its top inside of the recessed mounting location **202**. Tubular string **218** preferably has no external packers to seal the annulus **228** that extends around it. As shown in figure 24, it is possible for a guide nose **230** to be run on the

bottom of the expandable liner and retrieved after expansion by a retrieval tool 226 at the bottom of the expansion string.

[0066] Figures 25 - 29 illustrate a 2nd trip method of cementing the expanded liner. A cement retainer 234 is run in on a work string 236 below a shifting tool 232. First, the cement retainer 234 is to be set at the bottom of liner 218. At this point, any pressure tests can be performed to confirm that the cement retainer 234 is set properly as valve 200 is closed. Next as shown in figure 26, the running tool 235 for the cement retainer 234 is released and the work string 236 is tripped up hole. As the shifting tool 232 passes through the valve a similar collet assembly engages the groove 224. With this indication weight is set down and the drill string is turned to the right. Spring loaded dogs on the shifting tool 232 engage slots in the sliding sleeve valve 200 causing the sliding sleeve valve 200 to unscrew down opening it. Once the sliding sleeve valve 200 has been opened the work string 236 is tripped down hole reengaging the cement retainer running tool 235 into the cement retainer 234. As shown in figure 27, cement 237 is delivered through the work string 236, the shifting tool 232, the cement retainer running tool 235, and the cement retainer 234 and into the annulus 228 around the tubular string 218. Wellbore fluids 239 displaced by the pumped cement from annulus 228 go through sliding sleeve valve 200. In Figure 28, the shifting tool 232 is located in the sliding sleeve valve 200 and forces the sliding sleeve 200 shut on the way out trapping the cement 237 in the annulus 228. Figure 29 shows a separate trip in which the cement retainer 234 is milled out by a drill bit 244 before continuing on to drill the next hole section.

[0067] Yet another option is for the sliding sleeve valve 200 to be located in the top of the expanded liner string 218, just below the mounted section 231. This arrangement is shown in Figure 30. This sliding sleeve valve 200 would be expanded along with the liner string 218 which it is part of to allow for at least as large a drift as the parent casing above it. Once expanded it would be operated as mentioned above and all cementing methods discussed in this application could be applied.

[0068] A method of running the expandable liner string 218, mounting the upper section of the liner string 218 to the recessed mounting location 202 via expansion, continuing on to expand the entire liner string 218, setting a cement retainer 234 in the bottom of the expanded liner string 218, opening a sliding sleeve valve 200 for the return of displaced wellbore fluids 239 from the annulus 228, pumping cement 237 in to the annulus, and closing the sliding sleeve valve 200 in one trip is illustrated in Figures 31-35. The primary difference between this method and that detailed above and in Figures 25-29 is that the cement retainer 234 is run in on the same trip as the liner 218 and expansion tools 220. Figure 31 illustrates a liner 218 that has been delivered and mounted in the recessed mounting location 202 with the guide shoe 230 and the cement retainer 234 already in place as a combined device 246. As soon as the expandable liner 218 is mounted and adequate length has been expanded the sliding sleeve valve 200 can be opened as discussed above by shifting tool 232. The expansion tool 220 then returns to expanding the liner string 218. When the expansion tool 220 tags into the device 246, as shown in Figure 32, cement 237 can be pumped from the surface through the expansion string 236 that extends to the surface. As previously described, the displaced wellbore fluid 239 from cementing go through now open sliding sleeve 200 and to the surface through annulus 240. Figure 33 shows the cement 237 pumped into the annulus 228. Figure 34 shows the expansion string 236 removed which results in the closure of sliding sleeve valve 200. The device 246 has been left in the borehole for a subsequent trip with the mill or bit 244, as shown in Figure 35.

[0069] Figures 36 and 37 illustrate alternative ways to deliver a cementing shoe 268 to the lower end of a liner 270. In Figure 36, the shoe 268 is delivered with the liner 270 and sits on or near its bottom during the expansion with the swage 272. Eventually, a gripping device 274 engages the shoe 268 to allow it to pass well fluids in the case of cement being delivered into the annulus 276. After a pre-measured amount of cement is delivered the gripping device is raised to stop the cement in the annulus 276 from coming into the liner 270. This technique is illustrated in Figures 38-40. In Figure 38 arrows 278 indicate displaced well fluids from pumping cement represented by arrow 280 through ports 262. The cement is delivered down the string 282 and with the help of a diverter device known in the art allows the cement 280 to go down the annulus 270. After a pre-

measured quantity of cement has been delivered to the annulus **270** the swage **272** is picked up closing the passages in the shoe **268**, as shown in Figure 39. The shoe **268** is later drilled or milled as shown with a bit or mill **286**. The hole may then be drilled deeper and expanded in diameter with under-reamer **288**. While introducing cement at the top of the liner has been described those skilled in the art will appreciate that cement can be pumped down through the shoe **268** and well fluid displaced out openings such as **258** or **262**, as an alternative technique for cementing.

[0070] Figure 41 shows the expandable tubular or liner **300** delivering a cement isolation device **302** located near the lower end and inside the liner **300**. Figure 42 is the same except the cement isolation device is extending beyond the lower end of the liner **300**. In Figure 43 the liner **300** is expanded by the swage assembly **304** and the expansion has progressed to near the end of the liner. In Figure 44, the cement isolation device is captured as the swage assembly **304** finishes the expansion out through the end of the liner **300**. In Figure 45 the swage assembly **304** is raised up positioning the cement isolation device **302** in sealing contact with the liner **300**. In Figure 46 the cement **306** is pumped through the string **308** and the swage assembly **304** and into the annulus **310**. After cement delivery, the string and swage assembly **304** is removed and a mill **312** is run into the liner **300** to mill the cement isolation device **302** out. The cement isolation assembly can employ an actuable seal **314** that can be energized by pressure or mechanically or in other ways to seal against the inner wall of the liner **300** when brought back inside it. The ability to take the device **302** right through the liner **300** allows the swage assembly **304** to go clean through to the end of the liner **300** in expanding it. The actuable seal **314** then allows the device **302** to seal against the now enlarged liner **300**. The device **302** can be made of soft metals or non-metallic materials to shorten milling time shown in Figure 47. The advantage to delivering the device **302** below the liner **300** is that it can be larger so that after expansion of the liner **300** and the device **302** needs to be brought back into sealing contact in the liner, the gap to bridge is that much smaller. The device **302** can be configured to allow fluid to pass through in one or both directions during run in to facilitate insertion. While the tubular **300** is referred to as a liner other structures involving openings such as screens or slotted liners or casing can also be used

in the described method. Figures 41-47 illustrate a one trip deliver, expand and cement system.

[0071] The foregoing disclosure and description of the invention are illustrative and explanatory thereof, and various changes in the size, shape and materials, as well as in the details of the illustrated construction, may be made without departing from the spirit of the invention.

What is claimed is:

1. A completion method comprising:
running in a tubular to be expanded into a wellbore with a run in shoe adjacent a lower end thereof for attachment to an existing tubular;
expanding the tubular with a swage assembly;
engaging the run in shoe with said swage assembly;
finishing expansion to said lower end by advancing the now engaged run in shoe beyond said lower end;
providing a valve in the wall of the tubular to be expanded;
expanding said valve when the tubular is expanded;
operating said valve after it is expanded; and
removing the run in shoe through the now expanded tubular.
2. The method of claim 1, comprising operating said valve with said swage assembly.
3. The method of claim 1, comprising:
running in a cementing shoe on a string into the expanded tubular;
setting said cementing shoe in said expanded tubular;
operating said valve from said string; and
cementing through said string and cementing shoe.
4. The method of claim 3, comprising:
using said string to set said cementing shoe;
providing a shifting tool on said string;
releasing from said cementing shoe, when set, to shift said valve; and
tagging into said set shoe with said string after operating said valve.
5. A completion method, comprising:
running in a tubular to be expanded into a wellbore with a run in shoe adjacent a lower end thereof for attachment to an existing tubular;
expanding the tubular with a swage assembly;
engaging the run in shoe with said swage assembly;

removing the run in shoe through the now expanded tubular;
providing a valve in said existing tubular; and
operating said valve with said swage assembly.

6. The method of claim 5, comprising:
running in a cementing shoe on a string into the expanded tubular;
setting said cementing shoe in said expanded tubular;
operating said valve in said existing tubular from said string; and
cementing through said string and cementing shoe.
7. The method of claim 6, comprising:
using said string to set said cementing shoe;
providing a shifting tool on said string;
releasing from said cementing shoe, when set, to shift said valve in said
existing tubular; and
tagging into said set shoe with said string after operating said valve.

1/20

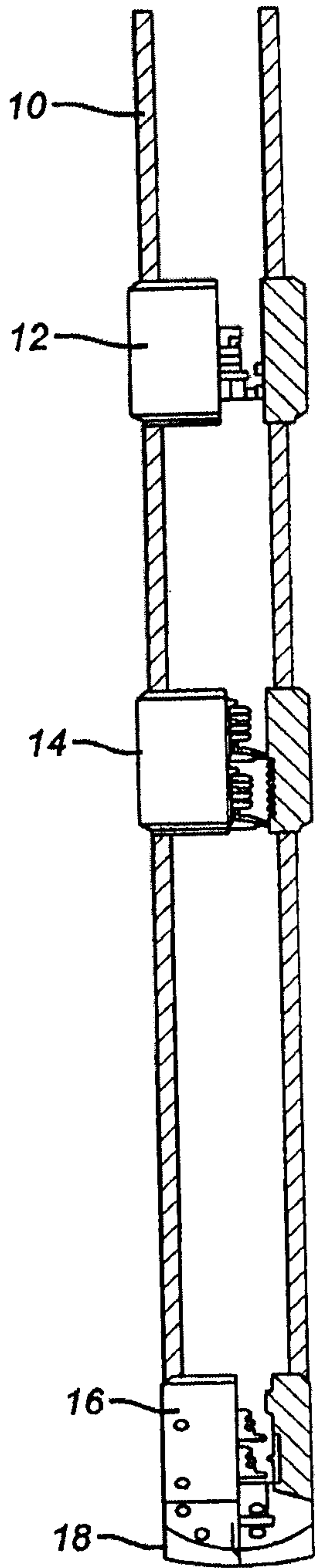

(PRIOR ART)
FIG. 1

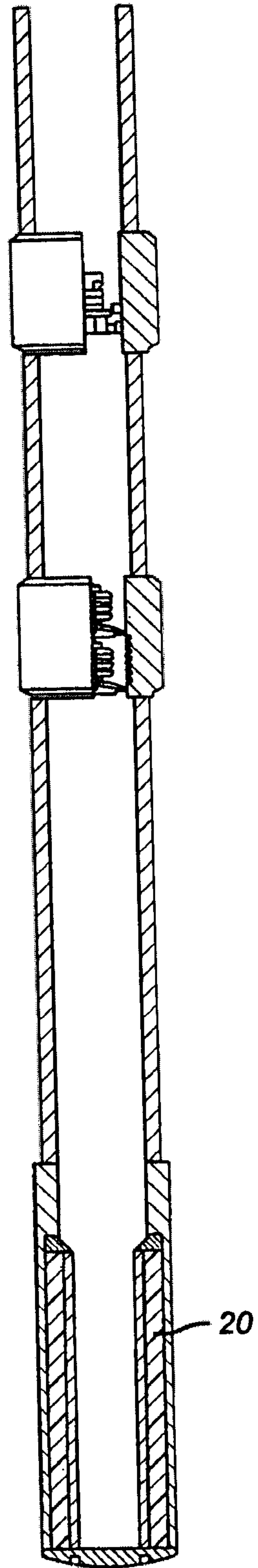

FIG. 2

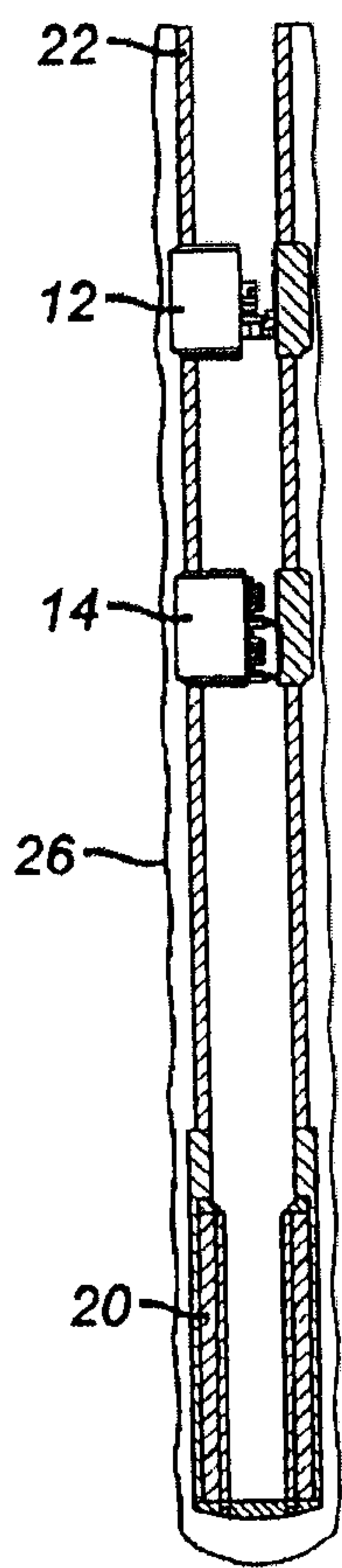

FIG. 3

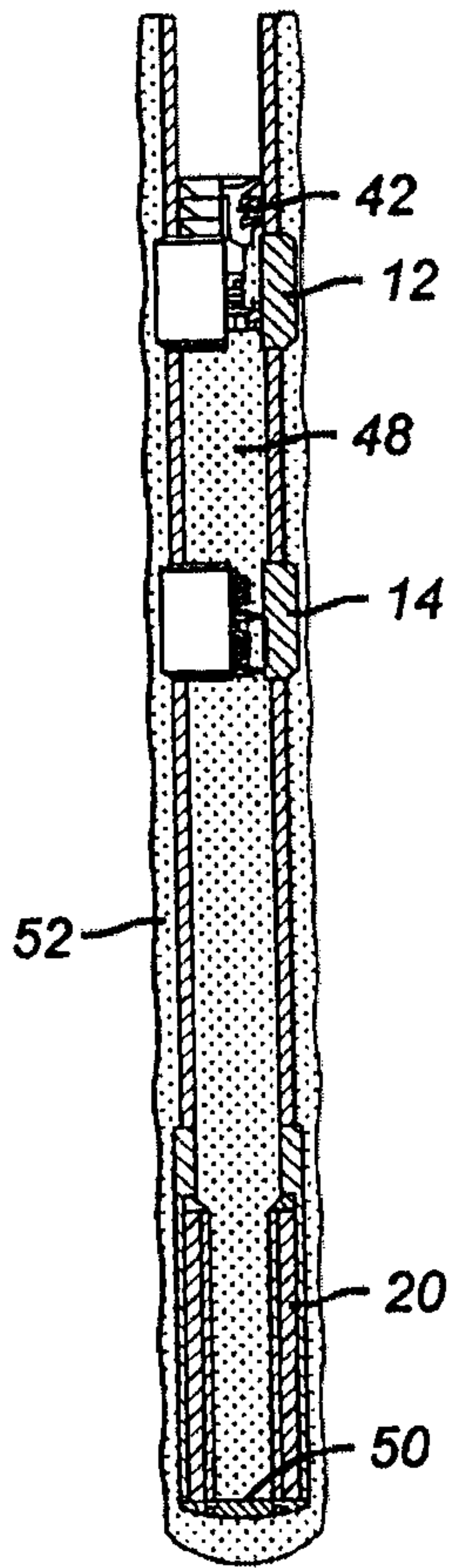

FIG. 4

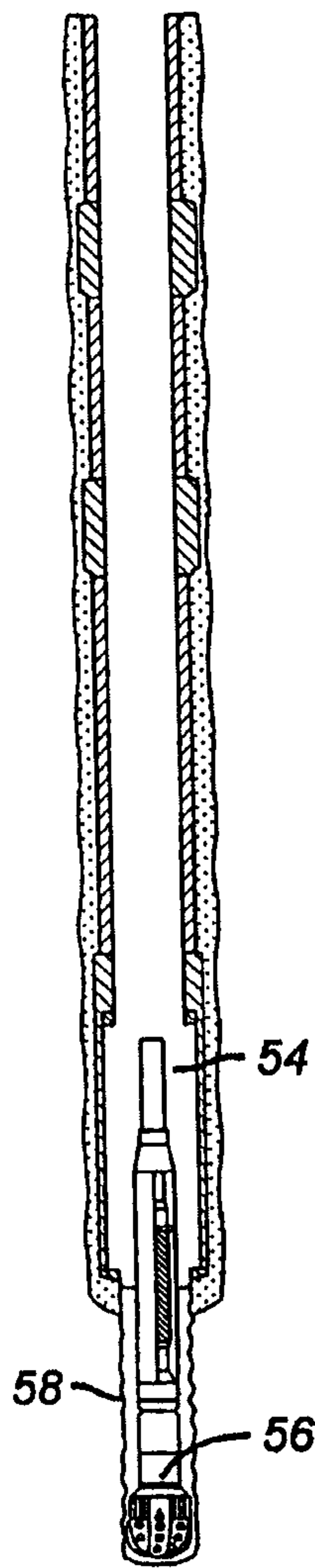

FIG. 5

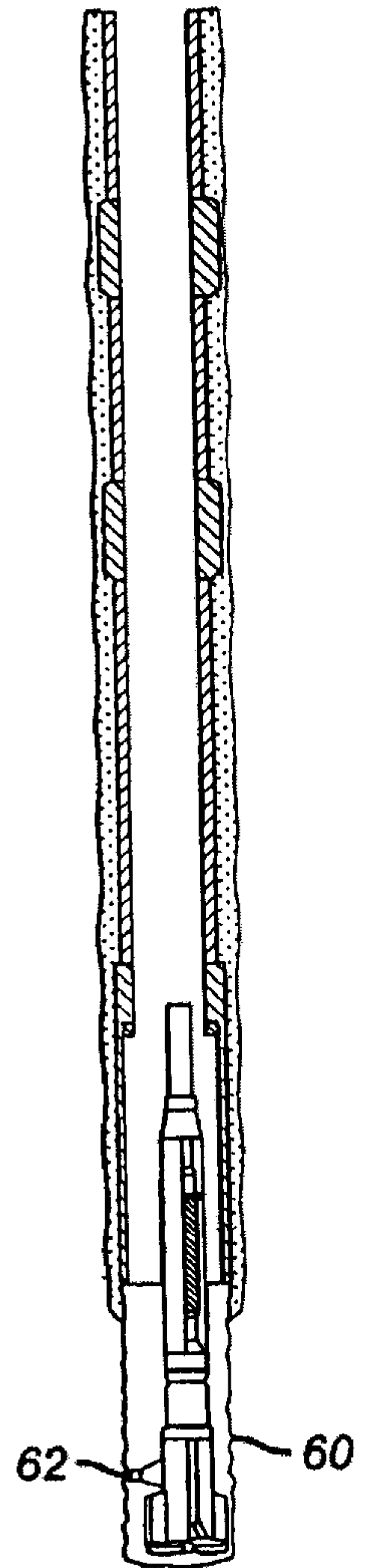

FIG. 6

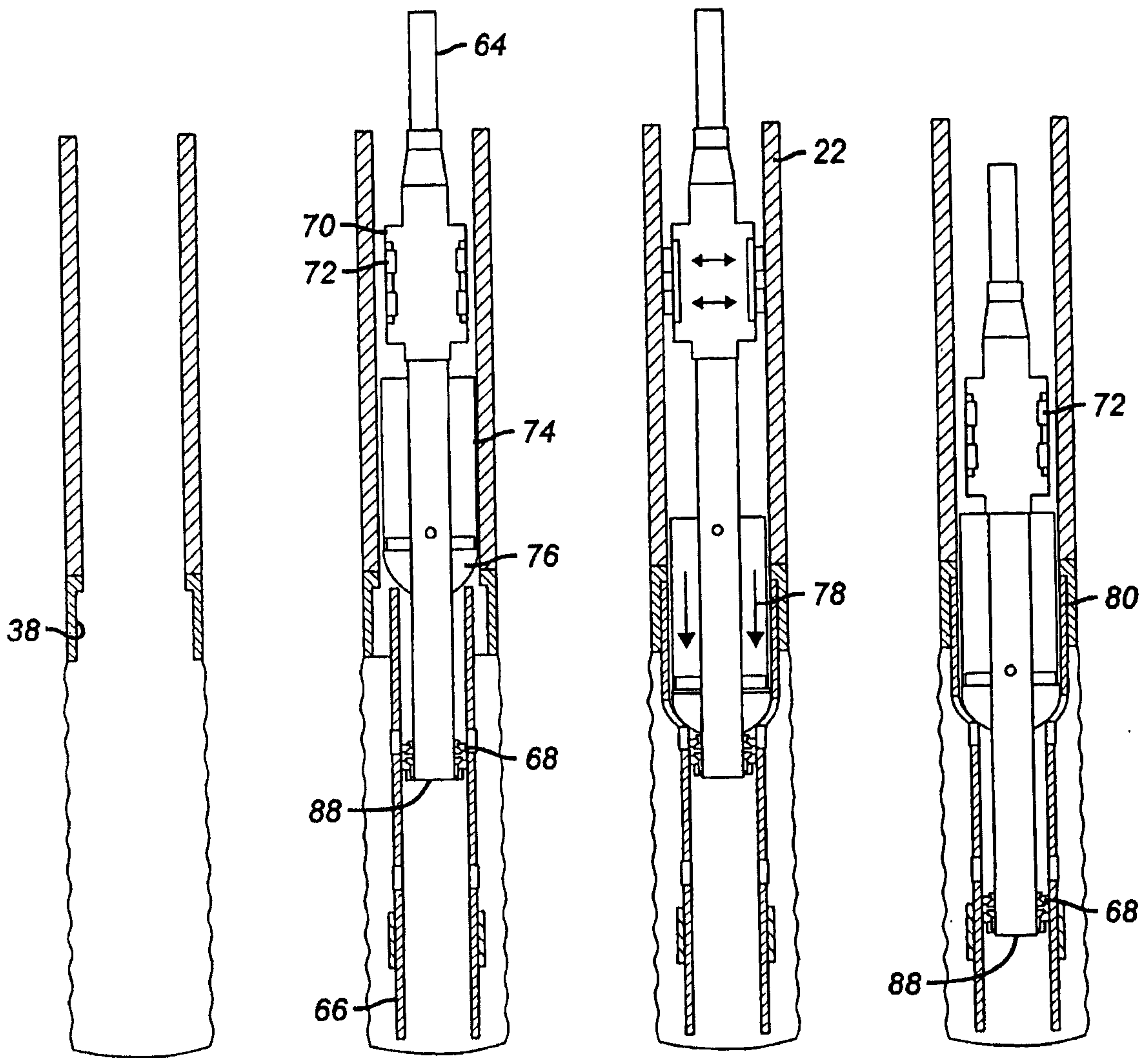

FIG. 7

FIG. 8

FIG. 9

FIG. 10

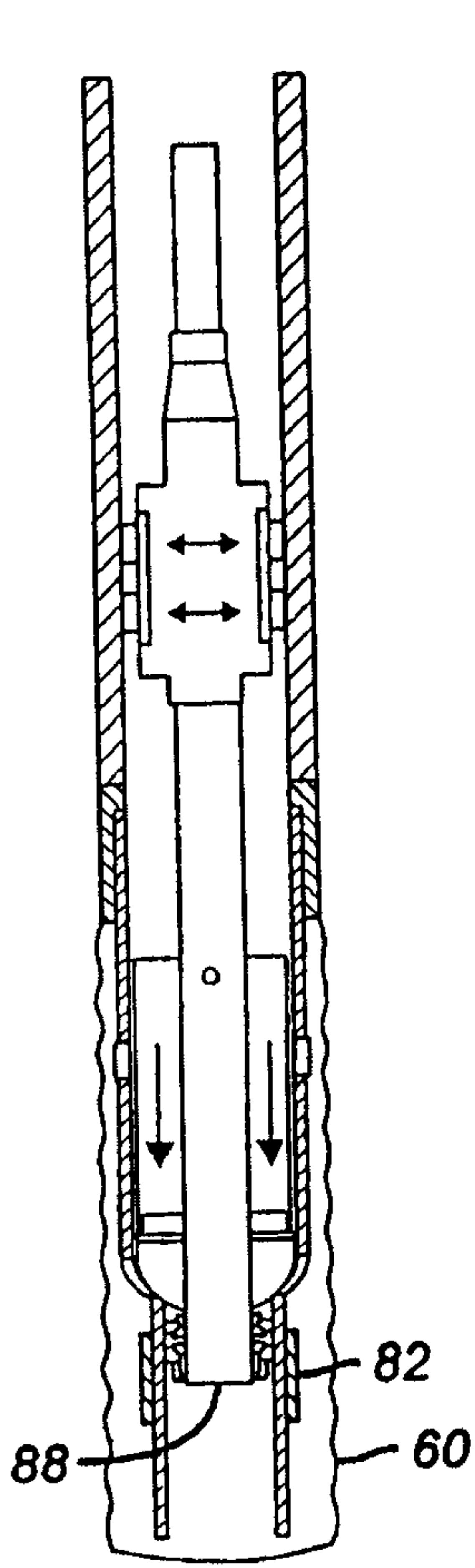

FIG. 11

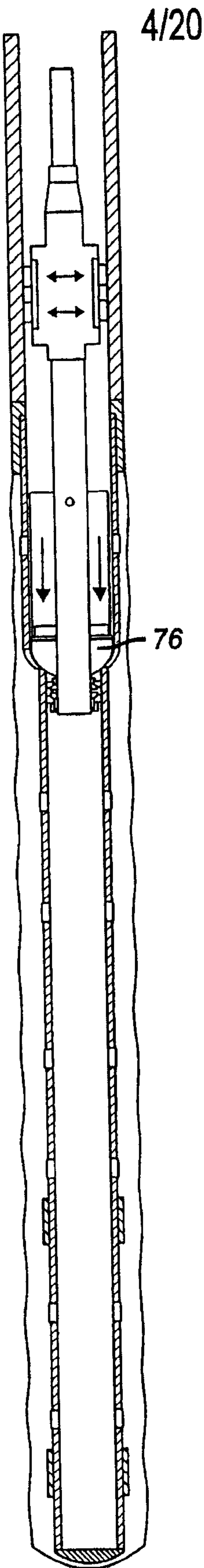

FIG. 12

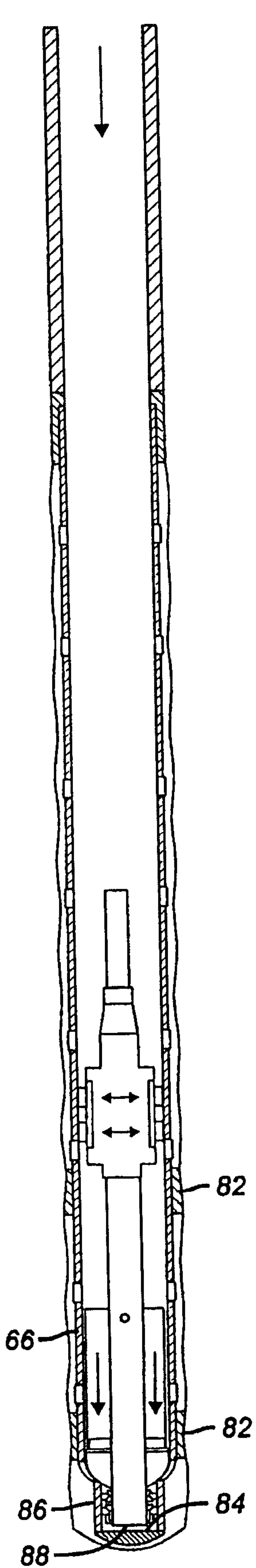

FIG. 13

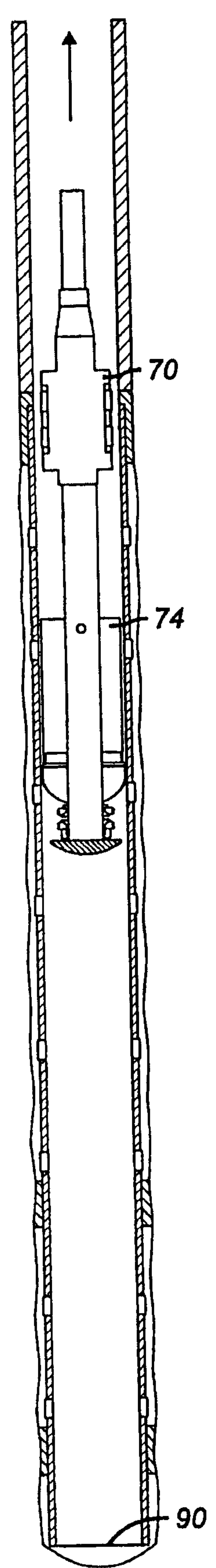

FIG. 14

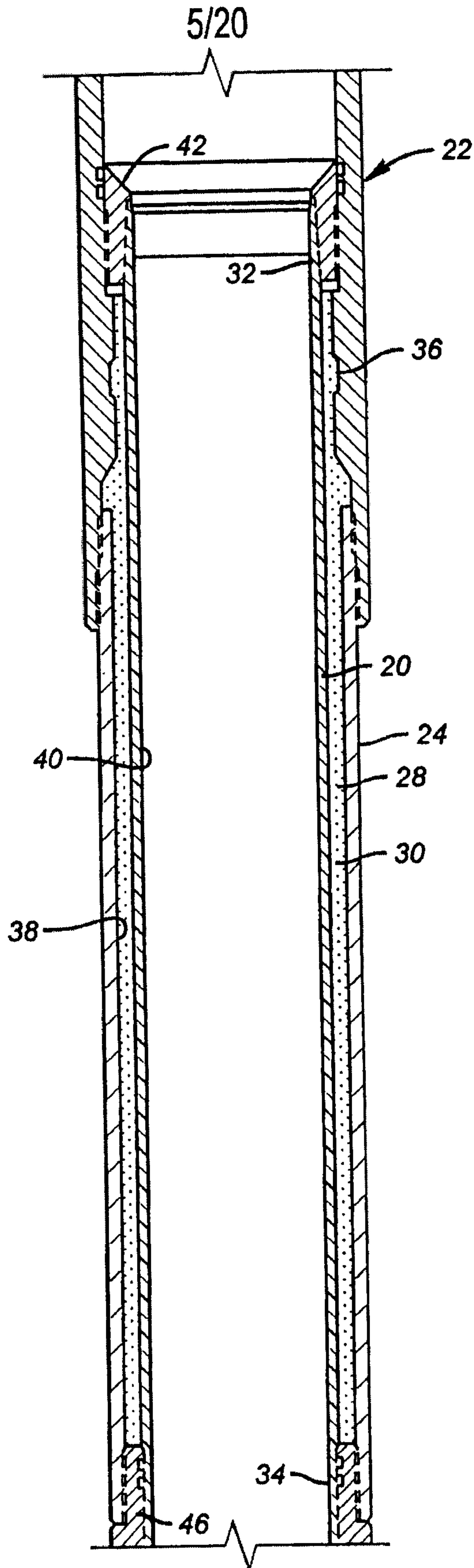

FIG. 15

6/20

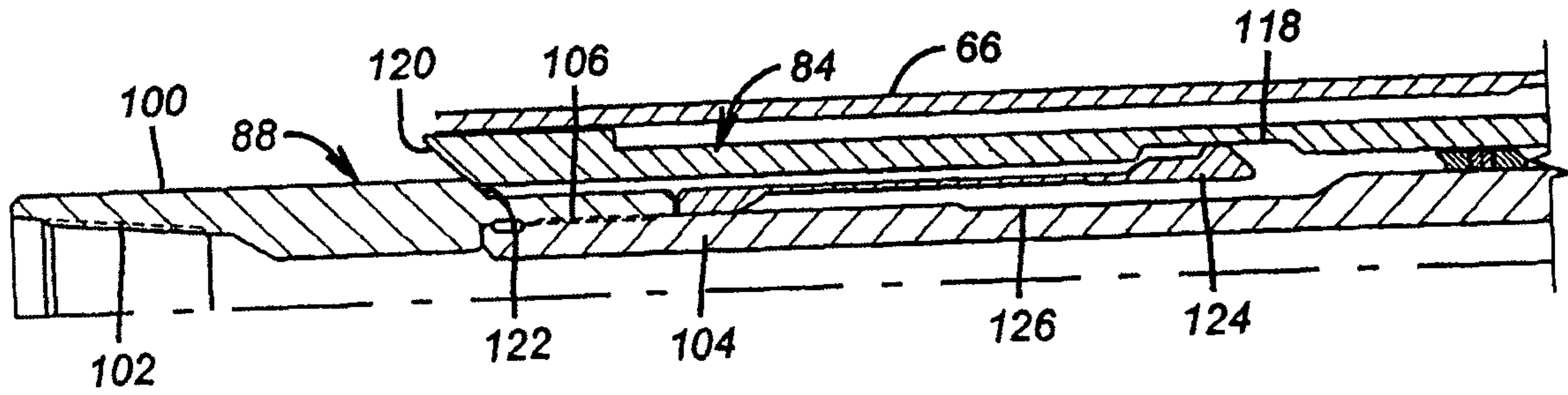

FIG. 16a

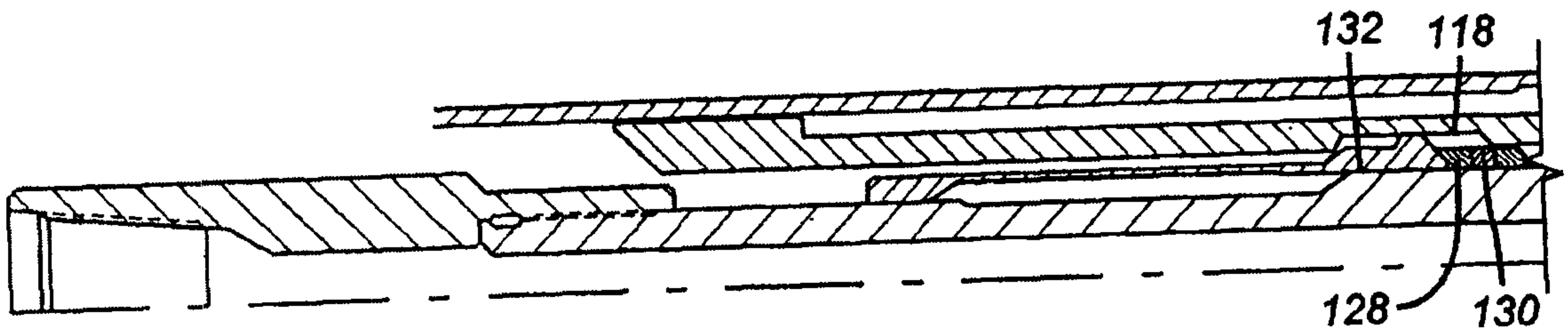

FIG. 17a

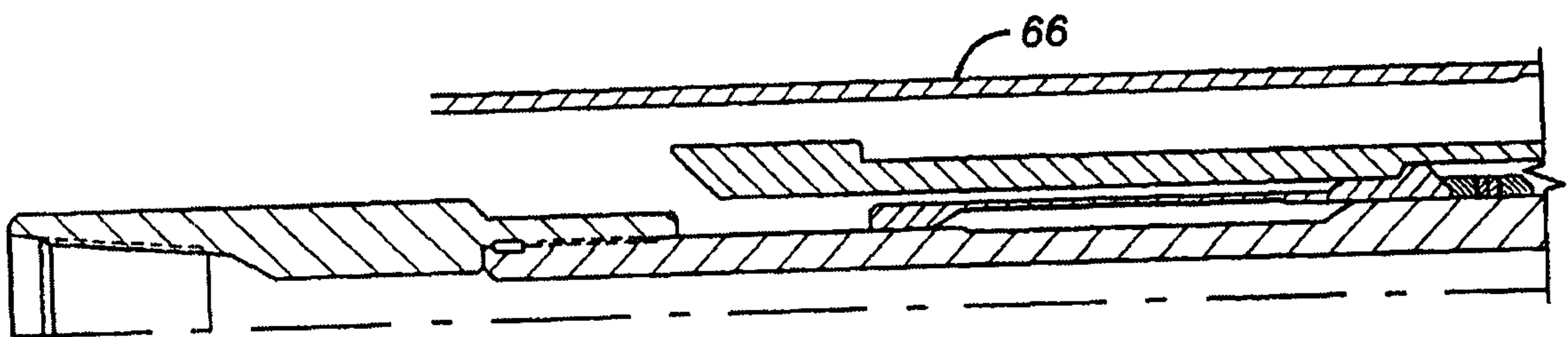

FIG. 18a

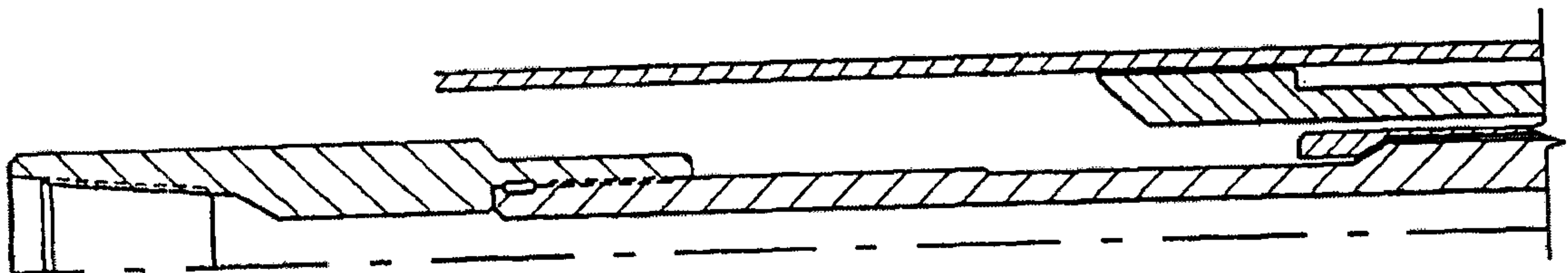

FIG. 19a

7/20

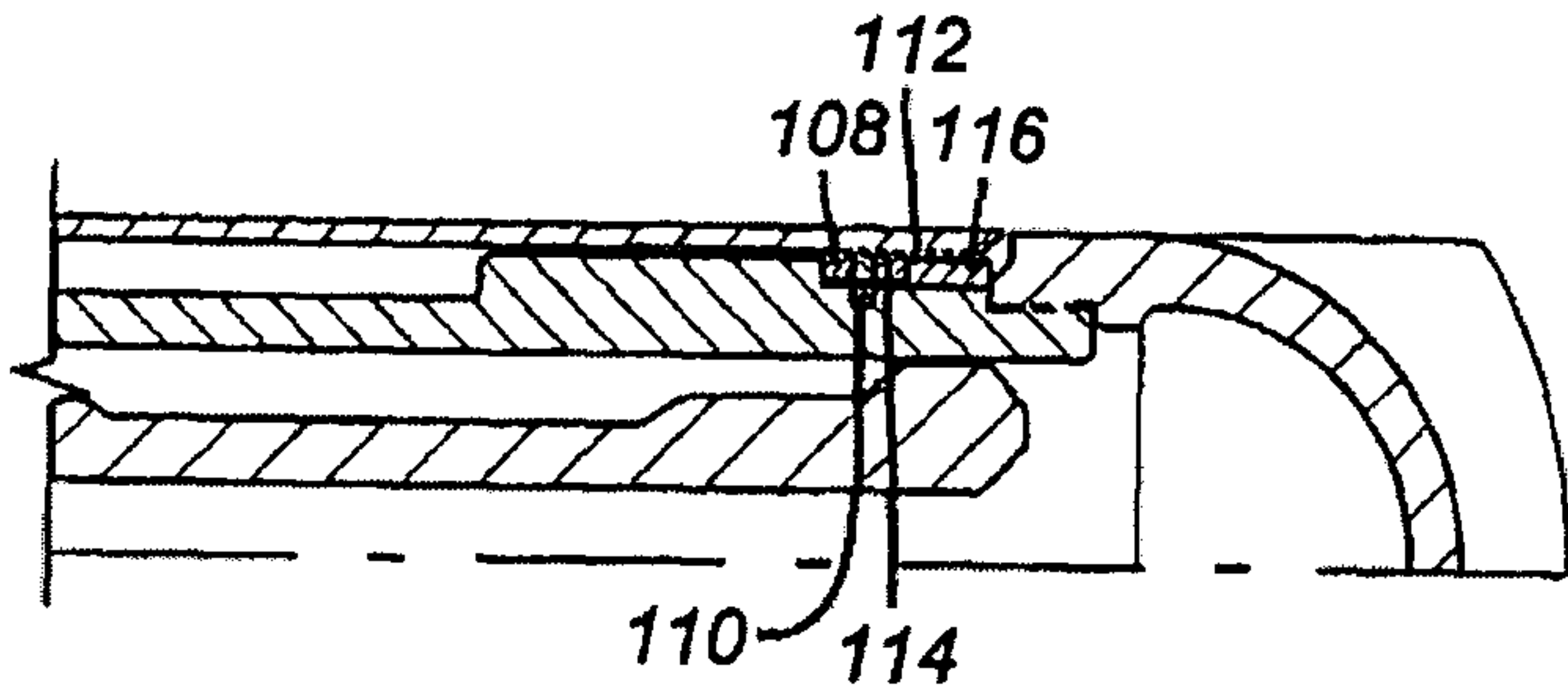

FIG. 16b

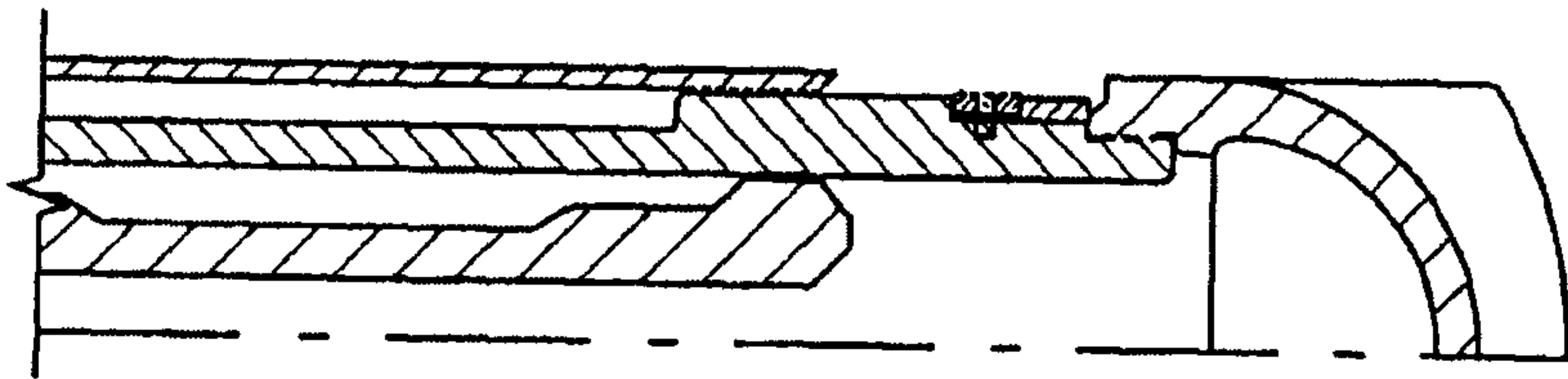

FIG. 17b

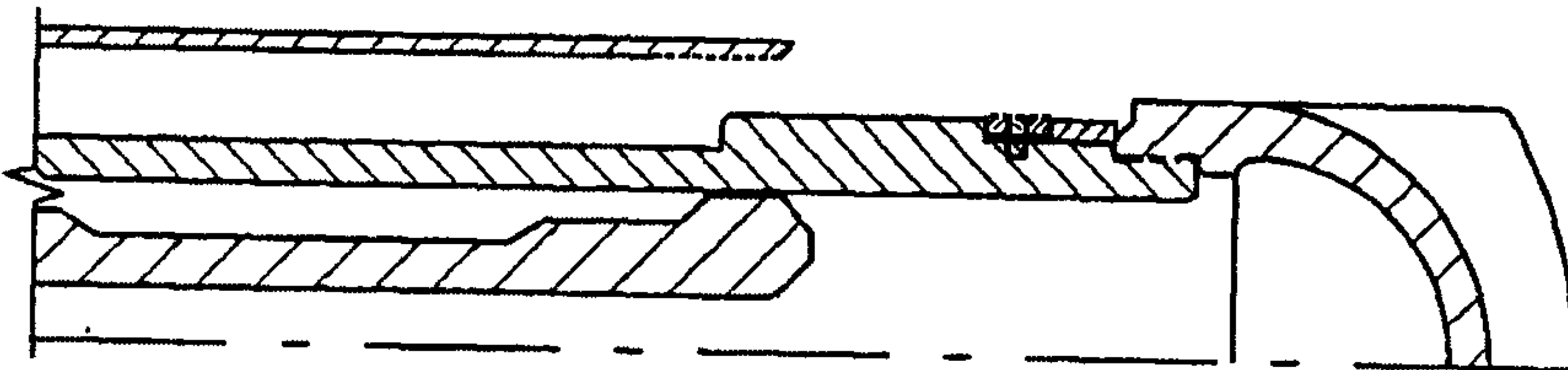

FIG. 18b

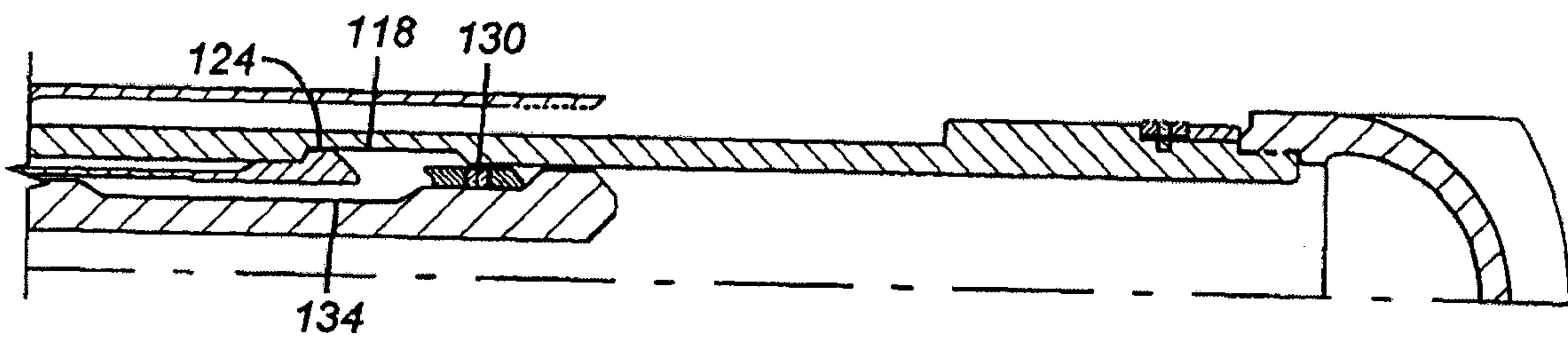

FIG. 19b

8/20

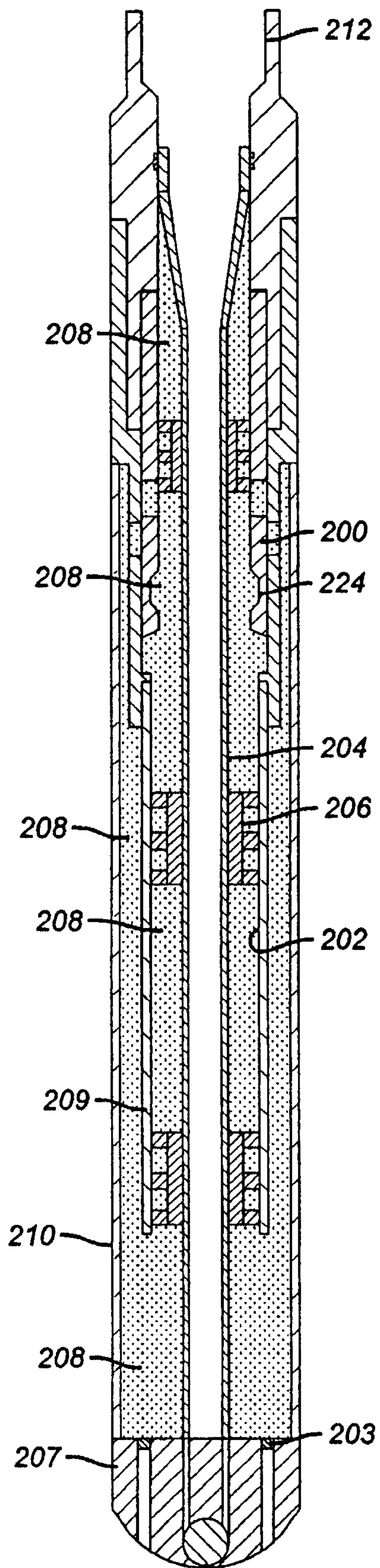

FIG. 20

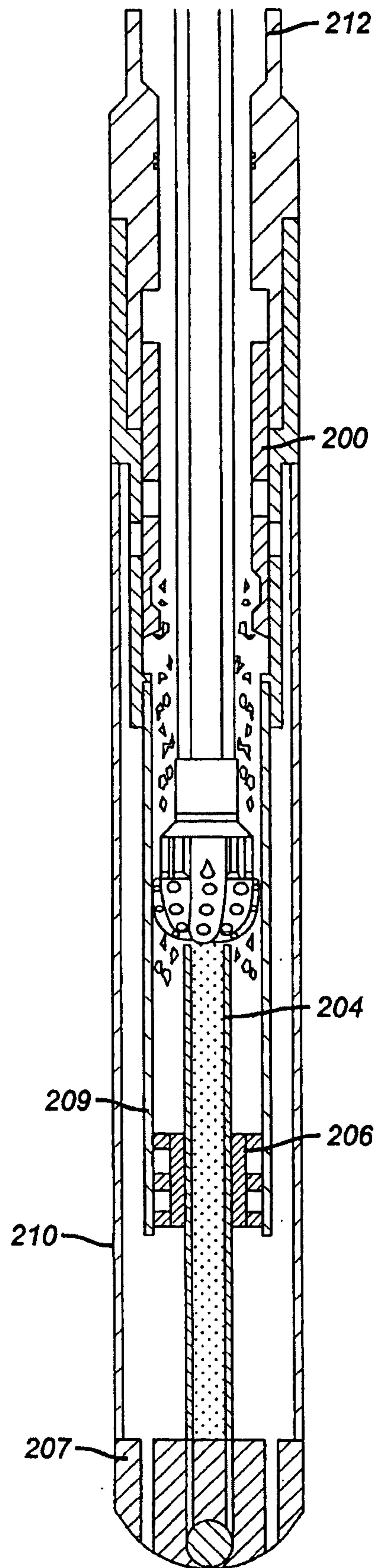

FIG. 21A

9/20

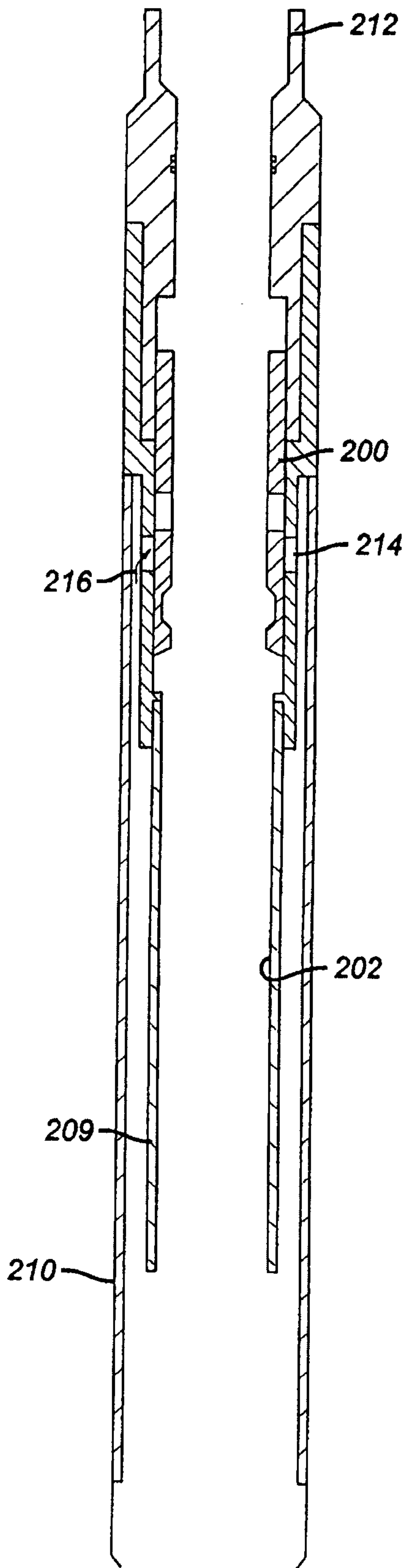

FIG. 21B

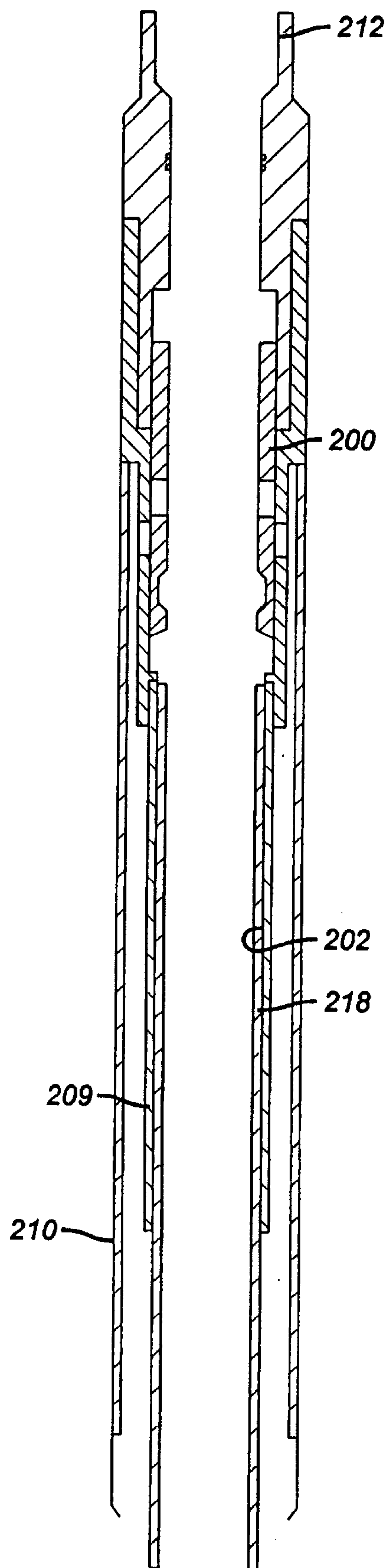

FIG. 22

10/20

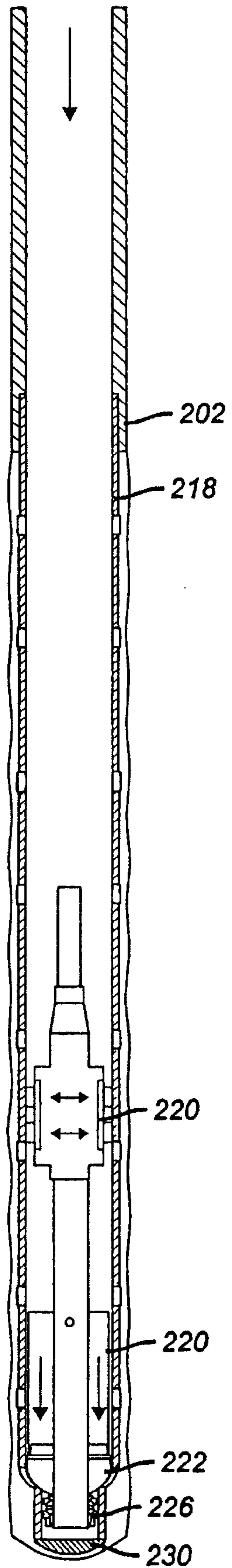

FIG. 23

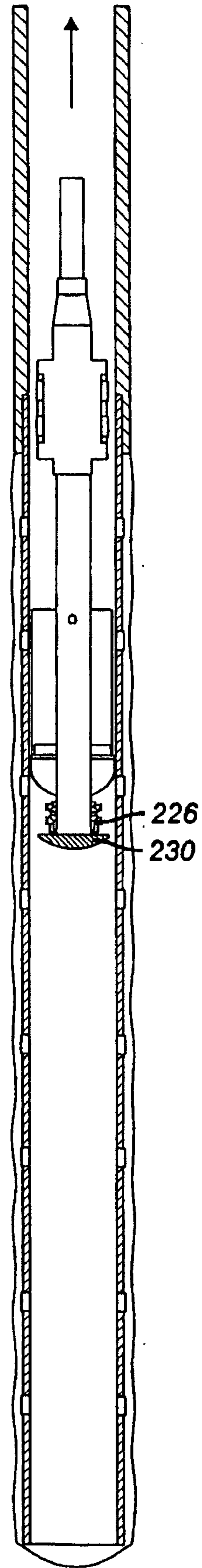

FIG. 24

11/20

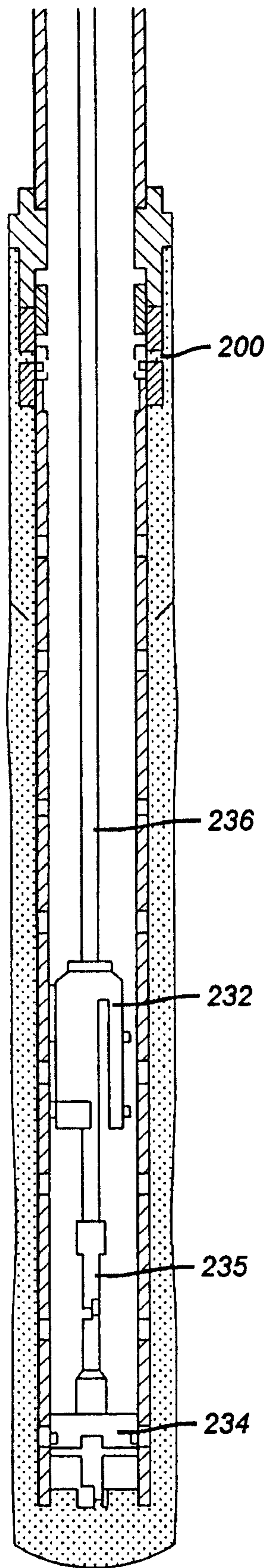

FIG. 25

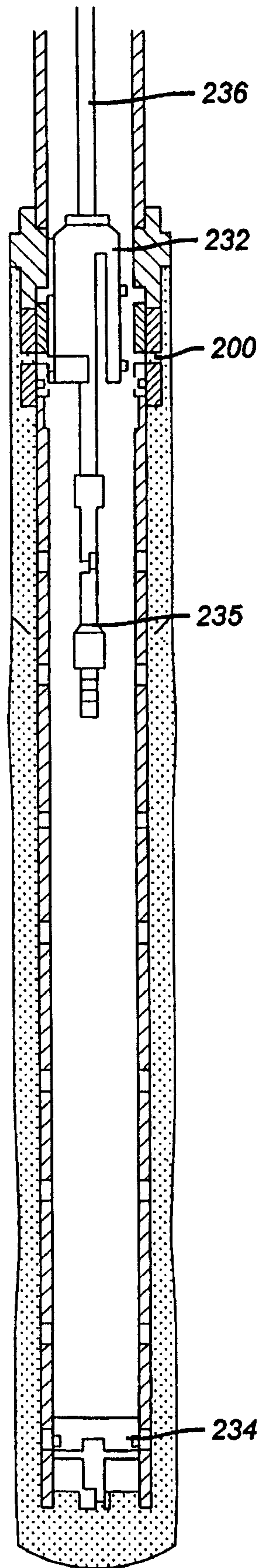

FIG. 26

12/20

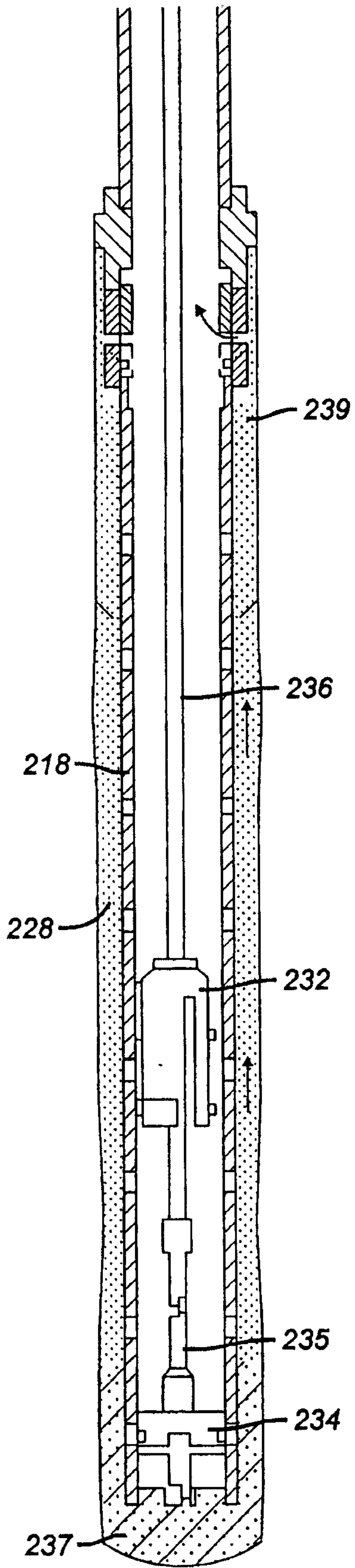

FIG. 27

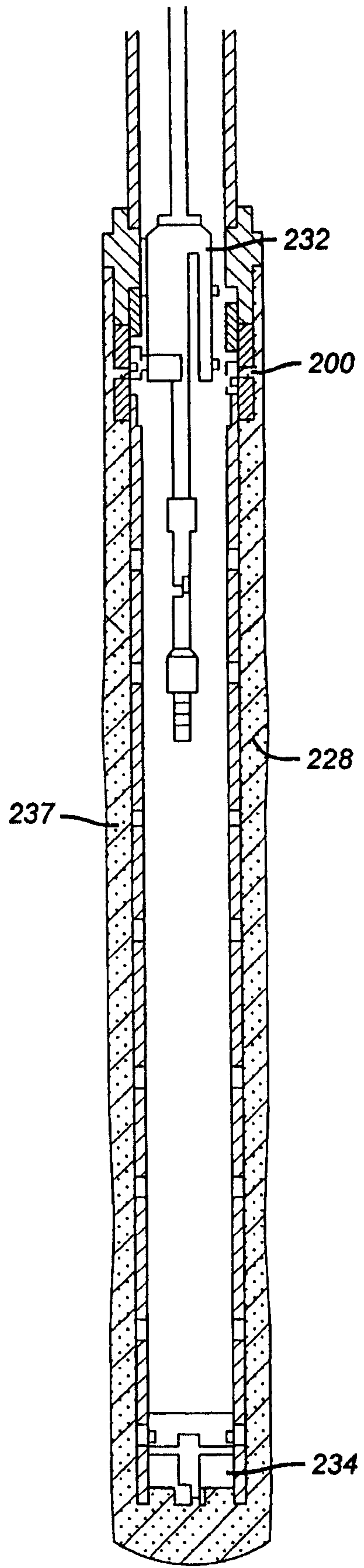

FIG. 28

13/20

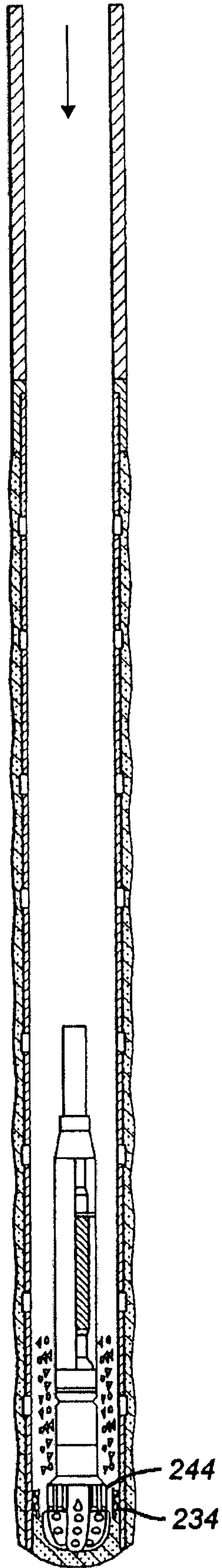

FIG. 29

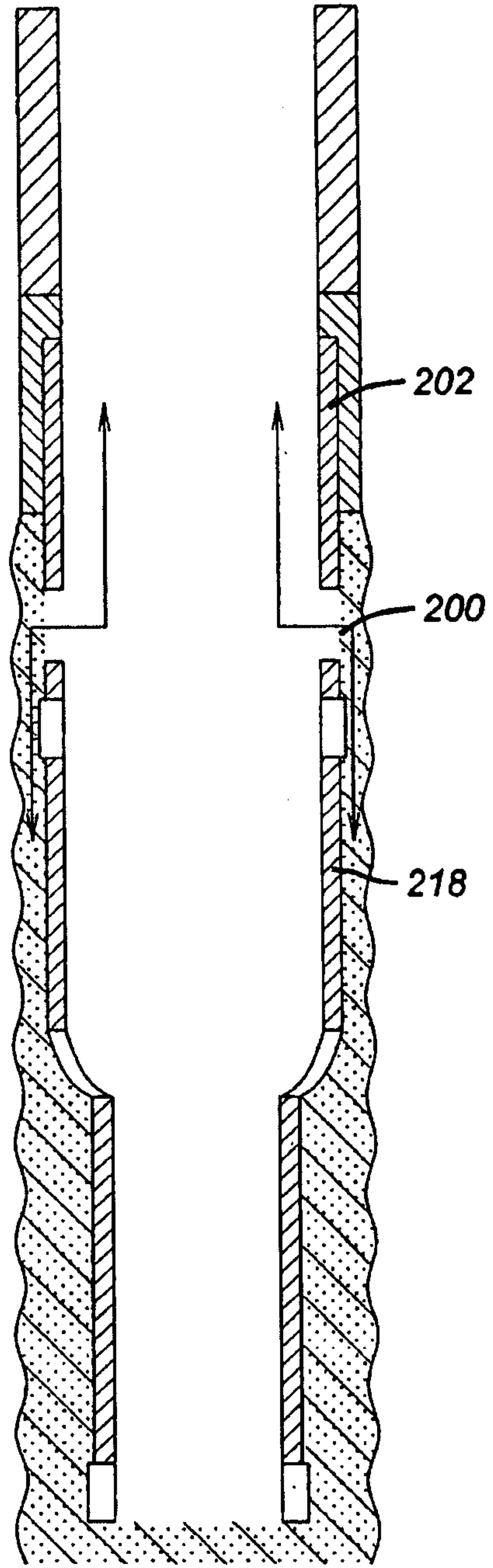

FIG. 30

14/20

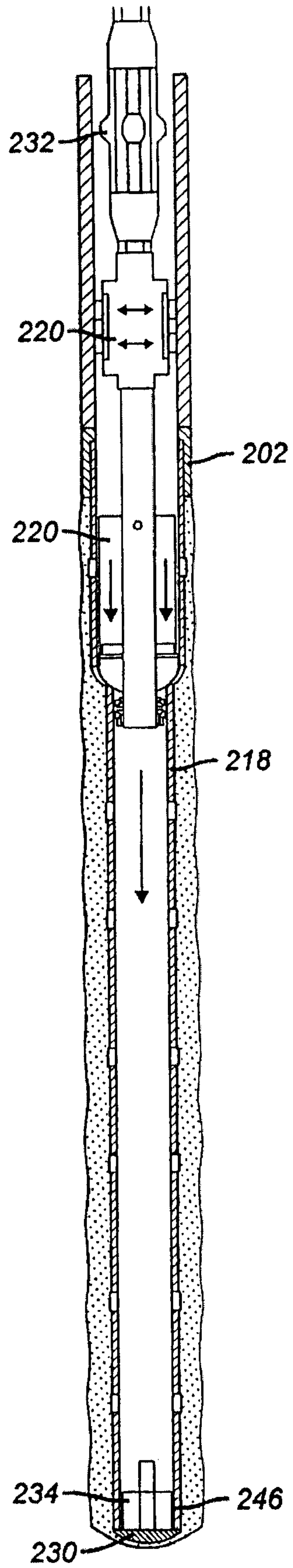

FIG. 31

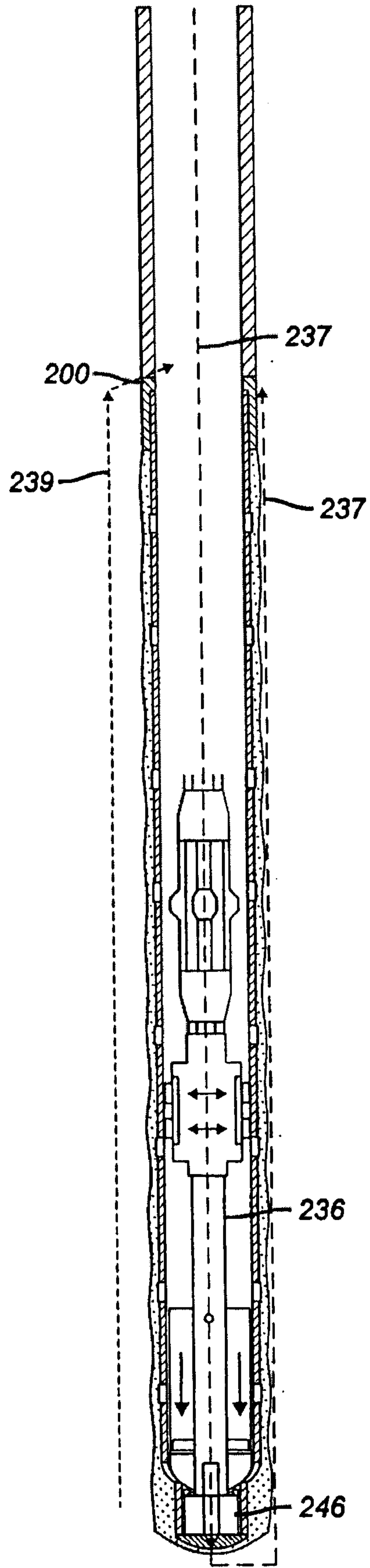

FIG. 32

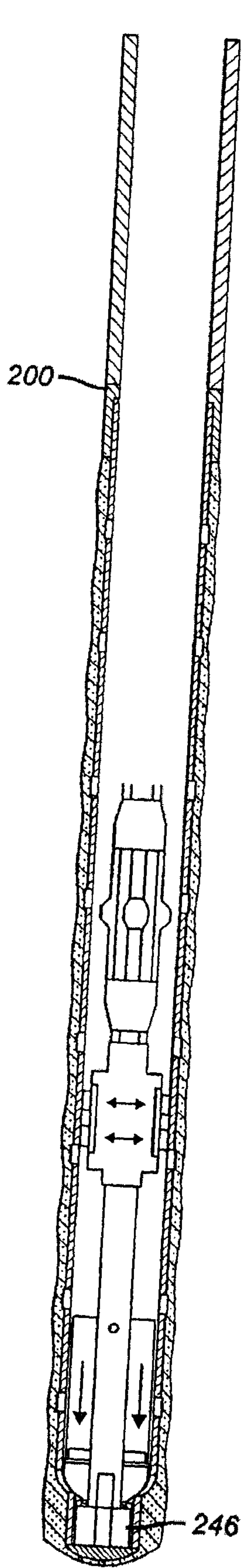

FIG. 33

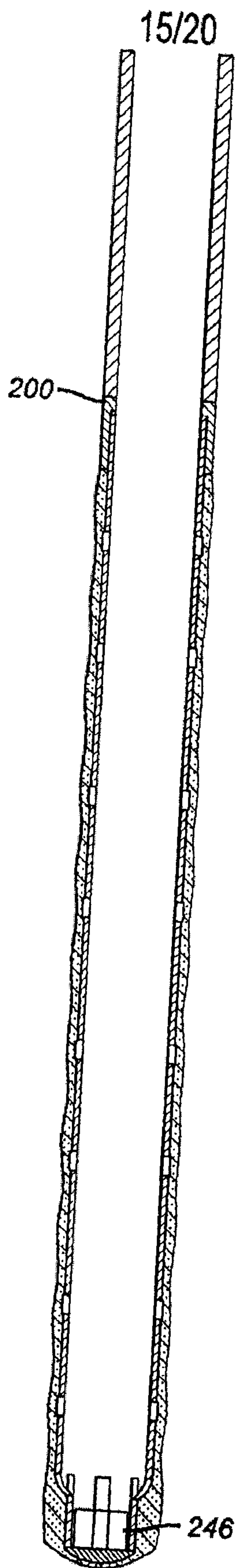

FIG. 34

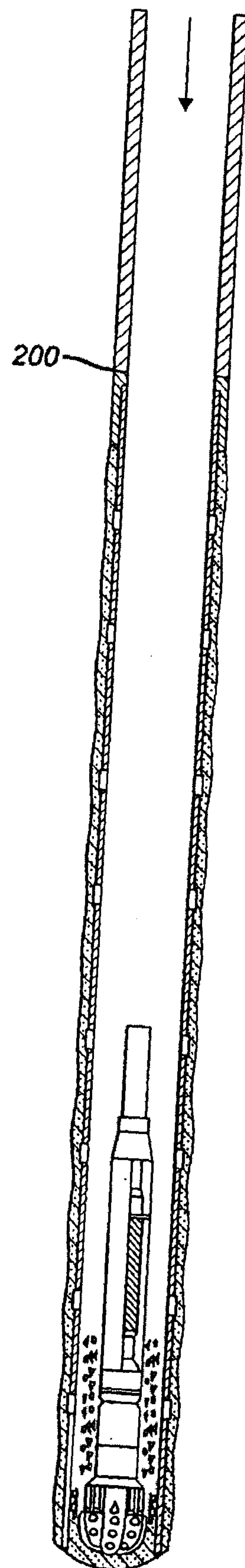

FIG. 35

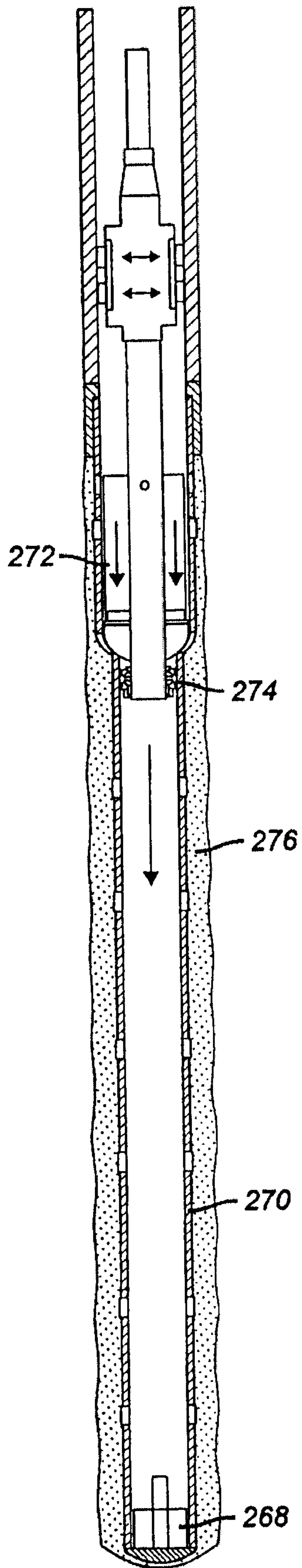

FIG. 36

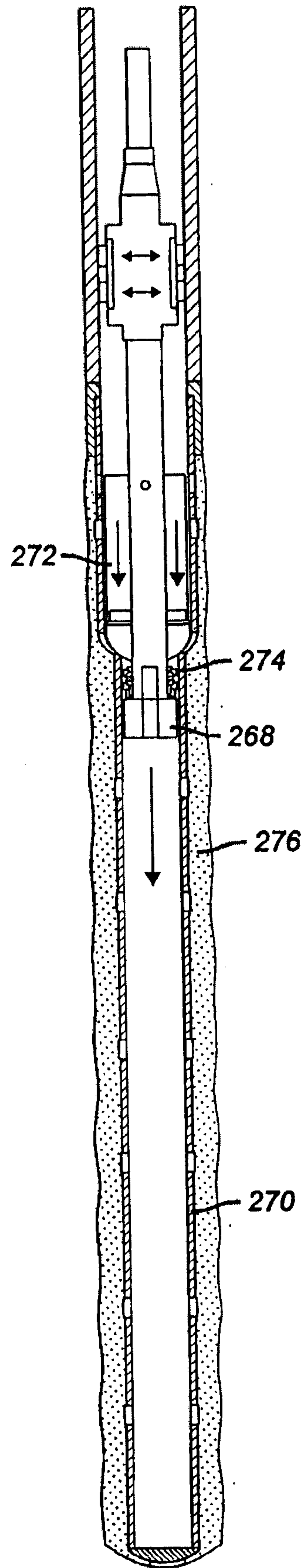

FIG. 37

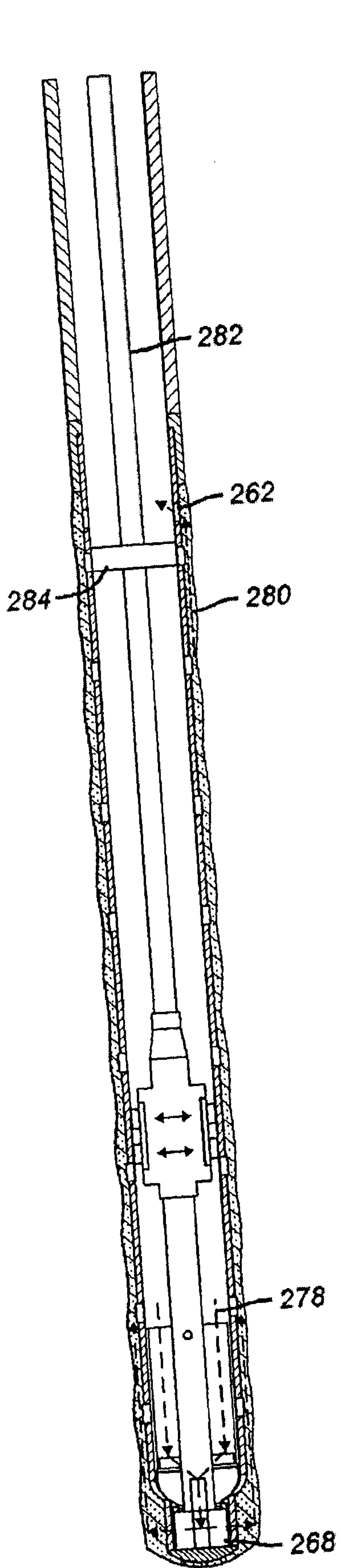

FIG. 38

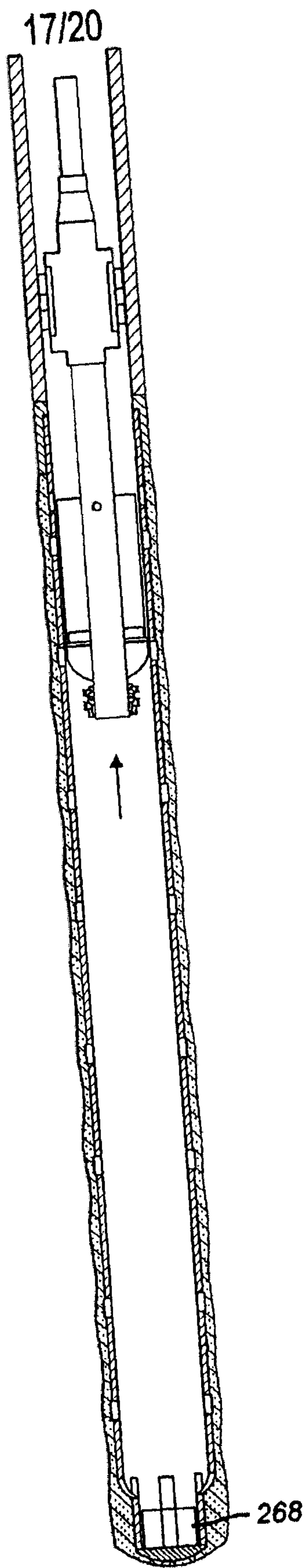

FIG. 39

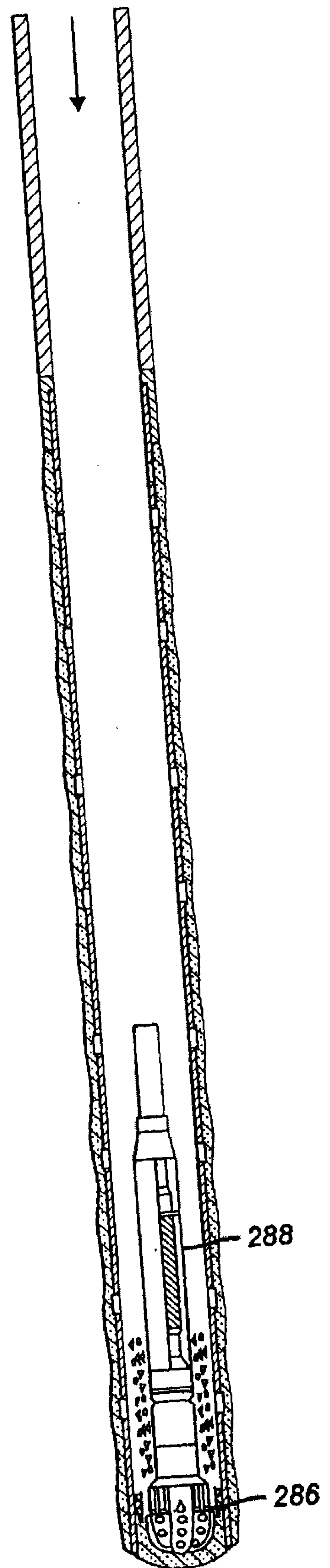

FIG. 40

18/20

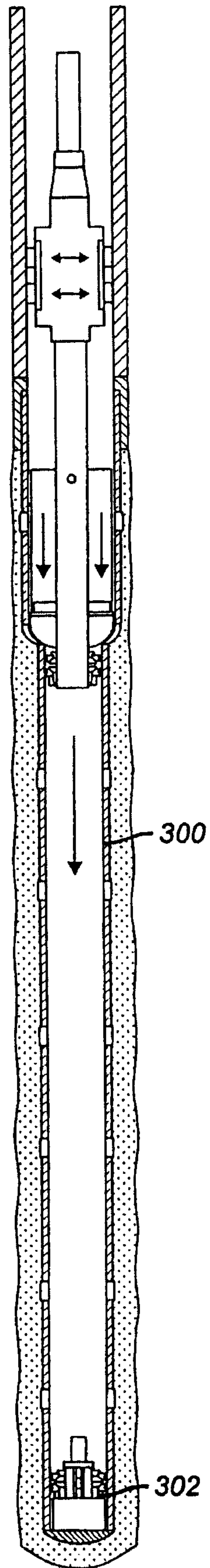

FIG. 41

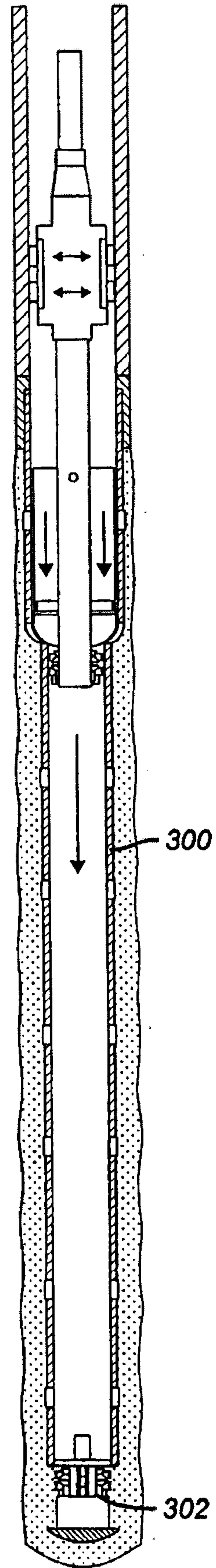

FIG. 42

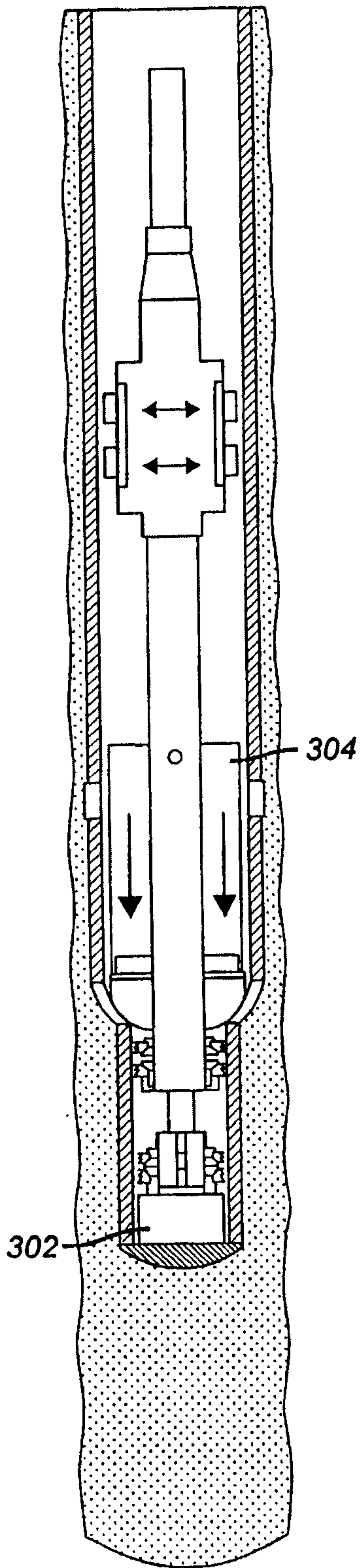

FIG. 43

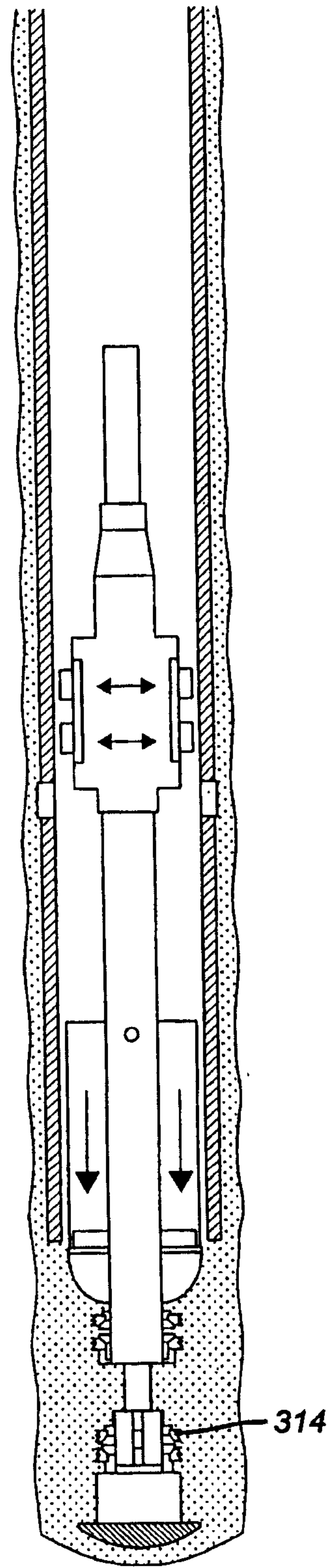

FIG. 44

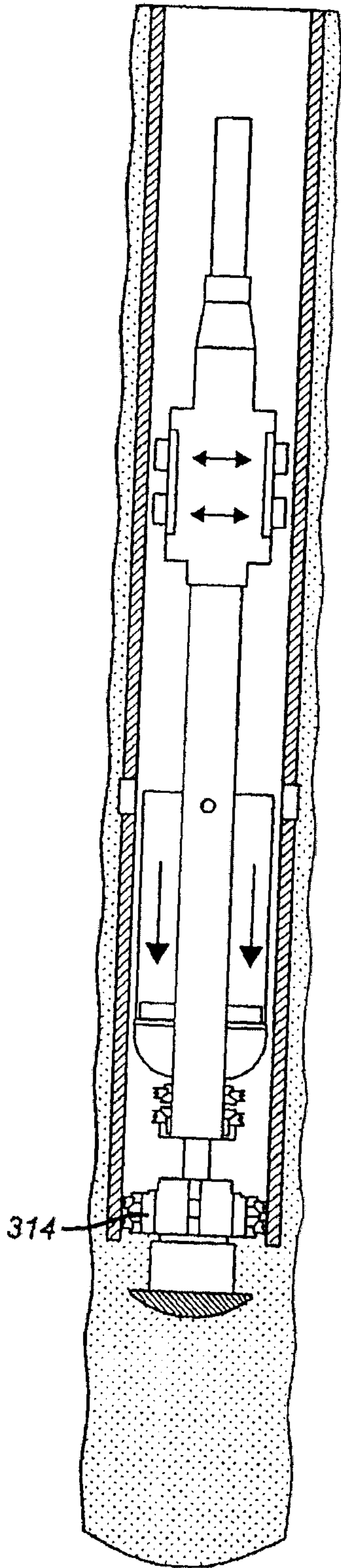

FIG. 45

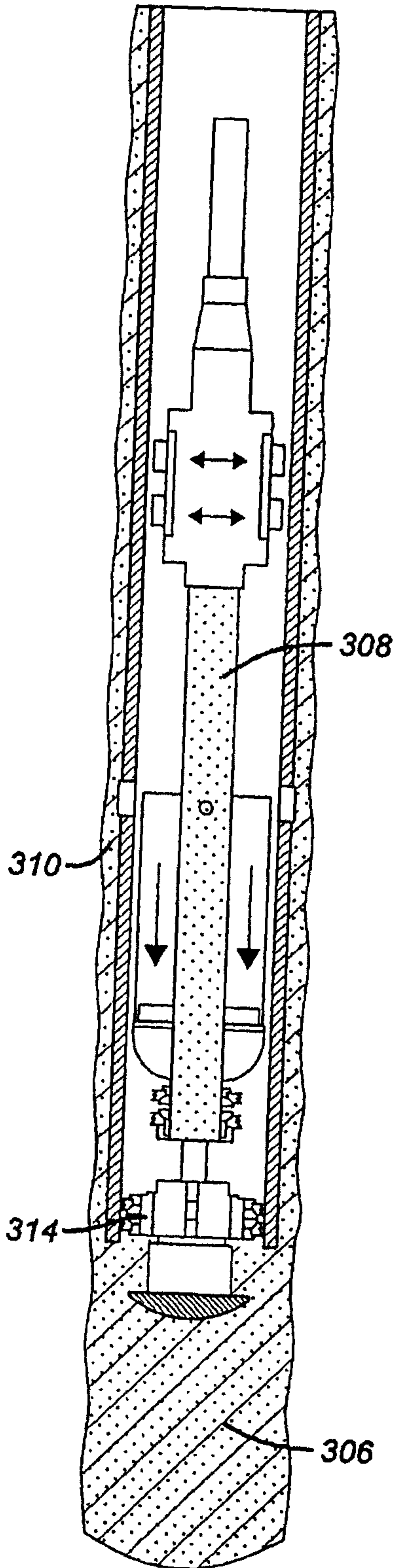

FIG. 46

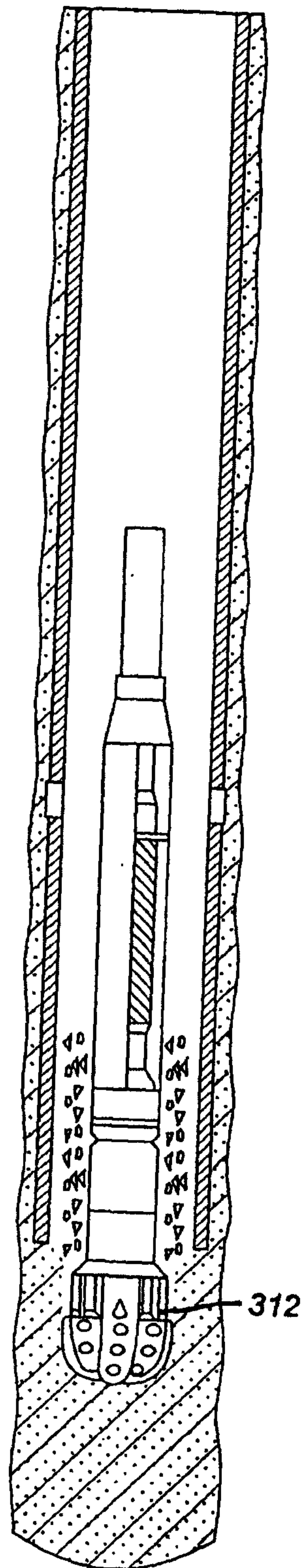

FIG. 47

