



(11) **EP 2 858 546 B1**

(12) **EUROPEAN PATENT SPECIFICATION**

(45) Date of publication and mention of the grant of the patent:  
**03.08.2016 Bulletin 2016/31**

(21) Application number: **13726230.9**

(22) Date of filing: **03.06.2013**

(51) Int Cl.:  
**A47L 15/50<sup>(2006.01)</sup>**

(86) International application number:  
**PCT/EP2013/061358**

(87) International publication number:  
**WO 2013/182512 (12.12.2013 Gazette 2013/50)**

(54) **A RACK SUITABLE FOR USING IN DISHWASHERS AND THE DISHWASHER WHEREIN THE RACK IS USED**

GESTELL ZUR VERWENDUNG IN GESCHIRRSPÜLMASCHINEN UND GESCHIRRSPÜLMASCHINE MIT DEM DARIN VERWENDETEN GESTELL

PANIER QUI CONVIENT POUR ÊTRE UTILISÉ DANS DES LAVE-VAISSELLE, ET LAVE-VAISSELLE DANS LEQUEL LE PANIER EST UTILISÉ

(84) Designated Contracting States:  
**AL AT BE BG CH CY CZ DE DK EE ES FI FR GB GR HR HU IE IS IT LI LT LU LV MC MK MT NL NO PL PT RO RS SE SI SK SM TR**

(30) Priority: **06.06.2012 TR 201206621**

(43) Date of publication of application:  
**15.04.2015 Bulletin 2015/16**

(73) Proprietor: **Arçelik Anonim Sirketi**  
**34950 Istanbul (TR)**

(72) Inventors:  
• **CETINKAYA, Ebru**  
**34950 Istanbul (TR)**  
• **EROZKAN, Gonca**  
**34950 Istanbul (TR)**  
• **GOKSU, Salih**  
**34950 Istanbul (TR)**  
• **HASKILIC, Hakan**  
**34950 Istanbul (TR)**

(56) References cited:  
**EP-A1- 1 275 336 EP-A1- 1 281 347**  
**EP-A2- 2 283 765 US-A- 3 779 258**

**EP 2 858 546 B1**

Note: Within nine months of the publication of the mention of the grant of the European patent in the European Patent Bulletin, any person may give notice to the European Patent Office of opposition to that patent, in accordance with the Implementing Regulations. Notice of opposition shall not be deemed to have been filed until the opposition fee has been paid. (Art. 99(1) European Patent Convention).

## Description

**[0001]** The present invention relates to a rack comprising an accessory whereon the objects to be washed are placed and the dishwasher wherein the rack is used.

**[0002]** In dishwashers, cutlery baskets are used that provide the small volume objects to be washed. When the cutlery basket cannot be entirely filled or is not used, the part of the cutlery basket that remains empty occupies unnecessary space inside the dishwasher and prevent loading of the other objects. When the cutlery basket volume is not sufficient, an additional washing unit is needed for washing the objects like forks and spoons.

**[0003]** In the state of the art International Patent Application No. WO2011154386, a cutlery basket is described which provides variable storage space by means of the storing units that move with respect to each other.

**[0004]** European Patent Application EP2283765 discloses a dishwasher rack comprising a shaft with a vertical axis and one carrier mounted on the shaft, whereon cutlery objects can be placed.

**[0005]** The aim of the present invention is the realization of a rack comprising an accessory which allows effective usage of the inner volume, and of a dishwasher wherein the rack is used.

**[0006]** The rack that is suitable for using in dishwashers, realized in order to attain the aim of the present invention and explicated in the claims, comprises an accessory having a shaft which extends in the vertical axis and more than one carrier which is mounted onto the shaft so as to rotate around the shaft and whereon the objects such as forks, spoons, etc. are placed.

**[0007]** By means of the carriers moving by rotating around the shaft in the vertical axis, the useable area of the accessory can be expanded and narrowed in the horizontal plane. As the carriers move closer to each other, the loading area narrows and as the carriers move away from each other, the loading area widens. Thus, the loading area is provided to be widened or narrowed according to the need when desired. When the horizontal and vertical axes of the carriers are aligned at the same level, the area of only one carrier can be used. When not in use, the accessory is kept inside the rack so as to allow the space of maximum one carrier to be used or is removed from the rack completely.

**[0008]** In an embodiment of the present invention, the carrier and the adjacent carrier are mounted onto the shaft one above the other so as to overlap with each other. The shaft provides the carriers to be held together in the same vertical direction and determines the rotational axis of the accessory.

**[0009]** In an embodiment of the present invention, the carrier has a first position wherein it is positioned almost one above the other with at least one other carrier and a second position wherein, by being rotated around the shaft, it is brought almost side by side with another carrier such that the objects can be placed on the carrier. While some of the carriers are in the first position, some of them

can be kept in the second position. Thus, a sufficient number of carriers are brought to the second position to provide a sufficient area whereon only the objects to be washed are placed and the unused carriers are prevented from occupying unnecessary space on the rack by being kept in the first position.

**[0010]** In an embodiment of the present invention, the shaft is disposed on the side wall of the rack. Thus, the accessory occupies less space inside the rack.

**[0011]** In an embodiment of the present invention, the shaft extends upwards from the base of the rack. The carriers are positioned on the shaft at a height that allows the objects to be placed in the space remaining below the carriers.

**[0012]** In an embodiment of the present invention, the carrier comprises at least one housing providing the carrier to be mounted onto the shaft. Thus, the carrier can be easily mounted onto the shaft. The housing is shaped so as to allow the carrier to rotate around the shaft.

**[0013]** In an embodiment of the present invention, at least one hole, wherein the objects like forks and spoons are placed, is located on the carrier. The holes may have different cross-sectional areas in order to facilitate the placement of the objects in different sizes.

**[0014]** In an embodiment of the present invention, at least two carriers overlap so that the objects can be placed in one hole on each carrier when the carriers are one above the other. Thus, the objects can be placed onto the carriers that almost completely overlap.

**[0015]** In an embodiment of the present invention, the carrier comprises at least one protrusion-shaped stopper. The protrusion-shaped stopper on the carrier provides the next carrier to stop by bearing against the edge thereof.

**[0016]** In an embodiment of the present invention, the rack comprises a support whereon the shaft is mounted. The support provides the carriers to be mounted to the rack in a more balanced manner.

**[0017]** In an embodiment of the present invention, at least one connection member providing the support to be mounted to the rack is disposed on the support. When the accessory is not in use, the support can be removed from the rack and can be mounted to the rack again when needed by means of the connection member.

**[0018]** In an embodiment of the present invention, the accessory is fan-shaped.

**[0019]** In an embodiment of the present invention, the carriers are shaped as triangles narrowing towards the housing.

**[0020]** By means of the present invention, the rack volume is provided to be used effectively by an accessory used for placing the objects like forks and spoons.

**[0021]** The model embodiments relating to the rack and the dishwasher, realized in order to attain the aim of the present invention, are illustrated in the attached figures, where:

Figure 1 - is the perspective view of a rack and an

accessory wherein the objects are placed in an embodiment of the present invention.

Figure 2 - is the perspective view of a rack and an accessory in an embodiment of the present invention.

Figure 3 - is the view of detail A in Figure 2.

Figure 4 - is the top perspective view of the carrier in an embodiment of the present invention.

**[0022]** The elements illustrated in the figures are numbered as follows:

1. Rack
2. Carrier
3. Shaft
4. Accessory
5. Housing
6. Hole
7. Stopper
8. Support
9. Connection member

**[0023]** The rack (1) of the present invention that is suitable for using in dishwashers comprises an accessory (4) having a shaft (3) which extends in the vertical axis and more than one carrier (2) which is mounted onto the shaft (3) so as to rotate around the shaft (3) and whereon the objects like forks and spoons are placed.

**[0024]** By means of the carriers (2) being rotated around the vertical axis formed by the shaft (3), the utilization space of the accessory (4) can be increased and decreased as needed. By opening only a sufficient number of carriers (2) to provide the area whereon the objects can be placed, the unused carriers (2) are prevented from occupying unnecessary space on the rack (1).

**[0025]** In an embodiment of the present invention, the carriers (2) are mounted onto the shaft (3) one above the other so as to at least partially overlap. By means of the shaft (3), the carriers (2) are held together in the same vertical direction. Furthermore, the carriers (2) can move over each other easily by being rotated around the shaft (3).

**[0026]** In an embodiment of the present invention, the carrier (2) has a first position wherein it is positioned almost one above the other with at least one other carrier (2) and a second position wherein it is brought almost side by side with the other carriers (2) by being rotated around the shaft (3) and the objects like forks and spoons are placed thereon. According to the need a desired number of carriers (2) are brought to the second position and the unused carriers (2) are kept in the first position in order to provide efficient utilization of the rack (1) volume.

**[0027]** In an embodiment of the present invention, the shaft (3) is disposed on the side wall of the rack (1). Thus, the carriers (2) mounted to the shaft (3) occupy less space on the rack (1) and the rack (1) volume is utilized

efficiently.

**[0028]** In an embodiment of the present invention, the shaft (3) extends upwards from the base of the rack (1). Thus, the objects to be washed can also be placed in the space remaining below the carriers (2) mounted to the shaft (3).

**[0029]** In an embodiment of the present invention, the carrier (2) comprises at least one housing (5) providing the carrier (2) to be mounted onto the shaft (3). The housing (5) bears the shaft (3).

**[0030]** In an embodiment of the present invention, the carrier (2) comprises at least one hole (6) wherein the objects like forks and spoons are placed. The holes (6) are shaped so as to allow the objects to be washed to be easily placed and removed.

**[0031]** In an embodiment of the present invention, at least two holes (6) overlap so as to allow the objects to be placed therein when at least two carriers (2) overlap. Thus, the objects can be placed onto the carriers (2) that almost completely overlap.

**[0032]** In an embodiment of the present invention, the carrier (2) comprises at least one protrusion-shaped stopper (7) that stops another carrier (2). The protrusion-shaped stopper (7) on the carrier (2) provides the next carrier (2) to stop by bearing against the edge of the carrier (2).

**[0033]** In an embodiment of the present invention, the rack (1) comprises a support (8) situated on the rack (1) and whereon the shaft (3) is mounted. The support (8) provides the shaft (3) and hence the carriers (2) carried by the shaft (3) to be mounted to the rack (1) in a more balanced manner.

**[0034]** In an embodiment of the present invention, the support (8) comprises at least one connection member (9) providing the support (8) to be mounted onto the rack (1). The connection member (9) provides the support (8) to be easily mounted to/dismounted from the rack (1).

**[0035]** In an embodiment of the present invention, the accessory (4) is fan-shaped.

**[0036]** In an embodiment of the present invention, the carrier (2) is triangle-shaped.

**[0037]** By means of the present invention, an accessory (4) is obtained that is used for placing the objects like forks and spoons into the dishwasher and that provides the user with loading spaces with variable sizes.

**[0038]** It is to be understood that the present invention is not limited to the embodiments disclosed above and a person skilled in the art can easily introduce different embodiments. These should be considered within the scope of the protection postulated by the claims of the present invention.

## Claims

1. A rack (1) that is suitable for using in dishwashers with an accessory (4) comprising a shaft (3) which extends in the vertical axis and **characterized by**

- more than one carrier (2) which is mounted onto the shaft (3) so as to rotate around the shaft (3) and whereon objects like forks and spoons can be placed.
2. A rack (1) as in Claim 1, **characterized by** the accessory (4), the utilization space of which can be increased and decreased by means of the carriers (2) being rotated around the vertical axis formed by the shaft (3).
  3. A rack (1) as in Claim 1 or 2, **characterized by** the carrier (2) having a first position wherein it is positioned almost one above the other with at least one other carrier (2) and a second position wherein it is brought almost side by side with the other carrier (2) by being rotated around the shaft (3) and the objects like forks and spoons are placed thereon.
  4. A rack (1) as in any one of the above claims, **characterized by** a shaft (3) whereon the carriers (2) are mounted one above the other so as to at least partially overlap.
  5. A rack (1) as in any one of the above claims, **characterized by** the shaft (3) which is disposed on the side wall of the rack (1).
  6. A rack (1) as in Claim 4, **characterized by** the shaft (3) that extends upwards from the base of the rack (1).
  7. A rack (1) as in any one of the above claims, **characterized by** the carrier (2) comprising at least one housing (5) that provides the carrier (2) to be mounted onto the shaft (3).
  8. A rack (1) as in any one of the above claims, **characterized by** the carrier (2) comprising at least one hole (6) wherein the objects like forks and spoons can be placed.
  9. A rack (1) as in Claim 8, **characterized by** the at least two holes (6) which overlap so as to allow the objects to be placed therein when at least two carriers (2) overlap.
  10. A rack (1) as in any one of the above claims, **characterized by** the carrier (2) comprising at least one protrusion-shaped stopper (7) that stops the other carriers (2).
  11. A rack (1) as in any one of the above claims, **characterized by** a support (8) whereon the shaft (3) is mounted.
  12. A rack (1) as in Claim 11, **characterized by** the support (8) comprising at least one connection member (9) that provides the support (8) to be mounted onto the rack (1).
  13. A rack (1) as in any one of the above claims, **characterized in that**, the accessory (4) is fan shaped.
  14. A rack (1) as in any one of the above claims, **characterized in that** the carrier (2) is triangle shaped.
  15. A dishwasher comprising a rack (1) as in any one of the above claims.

#### Patentansprüche

1. Gestell (1), das zur Verwendung in Geschirrspülern geeignet ist, umfassend ein Zubehörelement (4), das eine Welle (3) umfasst, die sich an der vertikalen Achse erstreckt, und **gekennzeichnet durch** mehrere Träger (2), die derart an der Welle (3) angebracht sind, dass sie sich um die Welle (3) drehen, und auf denen Gegenstände wie Gabeln und Löffel angeordnet werden können.
2. Gestell (1) nach Anspruch 1, **dadurch gekennzeichnet, dass** das der vom Zubehörelement (4) eingenommene Raum vergrößert oder verkleinert werden kann, indem die Träger (2) um die von der Welle (3) gebildete vertikale Achse gedreht werden.
3. Gestell (1) nach Anspruch 1 oder 2, **dadurch gekennzeichnet, dass** der Träger (2) eine erste Stellung, in der er mit wenigstens einem weiteren Träger (2) nahezu übereinander angeordnet ist, und eine zweite Stellung aufweist, in der er mit dem weiteren Träger (2) nahezu Seite an Seite gebracht ist, indem er um die Welle (3) gedreht wird und Gegenstände wie Gabeln und Löffel darauf angeordnet werden.
4. Gestell (1) nach einem der vorangehenden Ansprüche, **gekennzeichnet durch** eine Welle (3), an der Träger (2) übereinander angebracht sind, derart, dass sie sich wenigstens teilweise überlagern.
5. Gestell (1) nach einem der vorangehenden Ansprüche, **dadurch gekennzeichnet, dass** die Welle (3) an der Seitenwand des Gestells (1) angeordnet ist.
6. Gestell (1) nach Anspruch 4, **dadurch gekennzeichnet, dass** die Welle (3) sich von der Basis des Gestells (1) nach oben erstreckt.
7. Gestell (1) nach einem der vorangehenden Ansprüche, **dadurch gekennzeichnet, dass** der Träger (2) wenigstens ein Gehäuse (5) umfasst, dass ein Anbringen des Trägers (2) an der Welle (3) ermöglicht.
8. Gestell (1) nach einem der vorangehenden Ansprüche

- che, **dadurch gekennzeichnet, dass** der Träger (2) wenigstens ein Loch (6) umfasst, in dem die Gegenstände wie Gabeln und Löffel angeordnet werden können.
9. Gestell (1) nach Anspruch 8, **dadurch gekennzeichnet, dass** die wenigstens zwei Löcher (6) einander überlagern, damit Gegenstände darin angeordnet werden können, wenn sich zwei Träger (2) überlagern.
10. Gestell (1) nach einem der vorangehenden Ansprüche, **dadurch gekennzeichnet, dass** der Träger (2) wenigstens einen vorsprungförmigen Anschlag (7) umfasst, der die anderen Träger (2) anhält.
11. Gestell (1) nach einem der vorangehenden Ansprüche, **gekennzeichnet durch** einen Halter (8), an dem die Welle (3) angebracht ist.
12. Gestell (1) nach Anspruch 11, **dadurch gekennzeichnet, dass** der Halter (8) wenigstens ein Verbindungselement (9) umfasst, das ein Anbringen des Halters (8) am Gestell (1) ermöglicht.
13. Gestell (1) nach einem der vorangehenden Ansprüche, **dadurch gekennzeichnet, dass** der Träger (4) aus Kunststoff hergestellt ist.
14. Gestell (1) nach einem der vorangehenden Ansprüche, **dadurch gekennzeichnet, dass** der Träger (2) aus Kunststoff hergestellt ist.
15. Geschirrspüler, umfassend das Gestell (1) nach einem der vorangehenden Ansprüche.
- l'autre porteur (2) en étant tourné autour de l'arbre (3) et les objets comme des fourchettes, cuillères, etc. sont placés sur celui-ci.
- 5 4. Un panier (1) selon l'une quelconque des revendications précédentes, **caractérisé par** un arbre (3) sur lequel les porteurs (2) sont montés l'un au-dessus de l'autre de manière à se chevaucher au moins partiellement.
- 10 5. Un panier (1) selon l'une quelconque des revendications précédentes, **caractérisé par** l'arbre (3) qui est disposé sur la paroi latérale du panier (1).
- 15 6. Un panier (1) selon la Revendication 4, **caractérisé par** l'arbre (3) qui s'étend vers le haut à partir de la base du panier (1).
- 20 7. Un panier (1) selon l'une quelconque des revendications précédentes, **caractérisé par** le porteur (2) comprenant au moins un logement (5) qui permet au porteur (2) d'être monté sur l'arbre (3).
- 25 8. Un panier (1) selon l'une quelconque des revendications précédentes, **caractérisé par** le porteur (2) comprenant au moins un trou (6) dans lequel les objets comme des fourchettes, cuillères, etc. sont placés.
- 30 9. Un panier (1) selon la Revendication 8, **caractérisé par** l'au moins deux trous (6) qui se chevauchent de manière à permettre aux objets d'y être placés lorsqu'au moins deux porteurs (2) se chevauchent.
- 35 10. Un panier (1) selon l'une quelconque des revendications précédentes, **caractérisé par** le porteur (2) comprenant au moins une butée (7) en forme d'une protubérance qui arrête les autres porteurs (2).

## Revendications

1. Un panier (1) qui est adapté pour l'utilisation dans des lave-vaisselles, avec un accessoire (4) comprenant un arbre (3) qui s'étend dans l'axe vertical et **caractérisé par** plus d'un porteur (2) qui est monté sur l'arbre (3) de manière à tourner autour de l'arbre (3) et sur lequel des objets comme des fourchettes, cuillères, etc. peuvent être placés.
2. Un panier (1) selon la Revendication 1, **caractérisé par** l'accessoire (4) dont l'espace d'utilisation peut être augmenté et diminué au moyen des porteurs (2) étant tournés autour de l'axe vertical formé par l'arbre (3).
3. Un panier (1) selon la Revendication 1 ou 2, **caractérisé par** le porteur (2) qui présente une première position où il est positionné à peu près l'un sur l'autre avec au moins un autre porteur (2) et une deuxième position où il est apporté à peu près côte à côte avec
- 40 11. Un panier (1) selon l'une quelconque des revendications précédentes, **caractérisé par** un support (8) sur lequel l'arbre (3) est monté.
- 45 12. Un panier (1) selon la Revendication 11, **caractérisé par** le support (8) comprenant au moins un élément de raccordement (9) qui permet au support (8) d'être monté sur le panier (1).
- 50 13. Un panier (1) selon l'une quelconque des revendications précédentes, **caractérisé par** l'accessoire (4) est en forme de ventilateur.
- 55 14. Un panier (1) selon l'une quelconque des revendications précédentes, **caractérisé en ce que** le porteur (2) est triangulaire.
15. Un lave-vaisselle comprenant un panier (1) selon l'une quelconque des revendications précédentes.

Figure 1

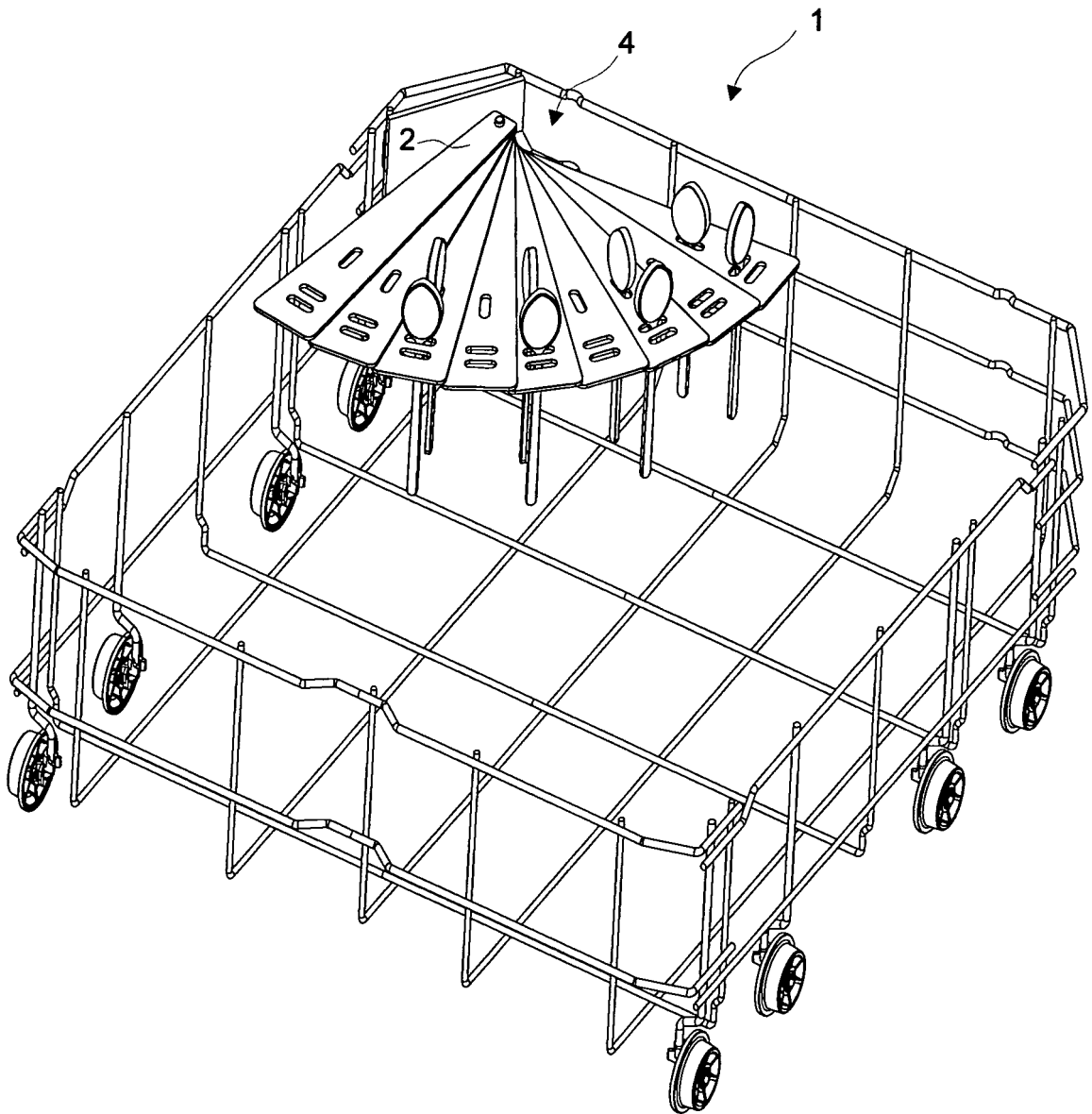

Figure 2

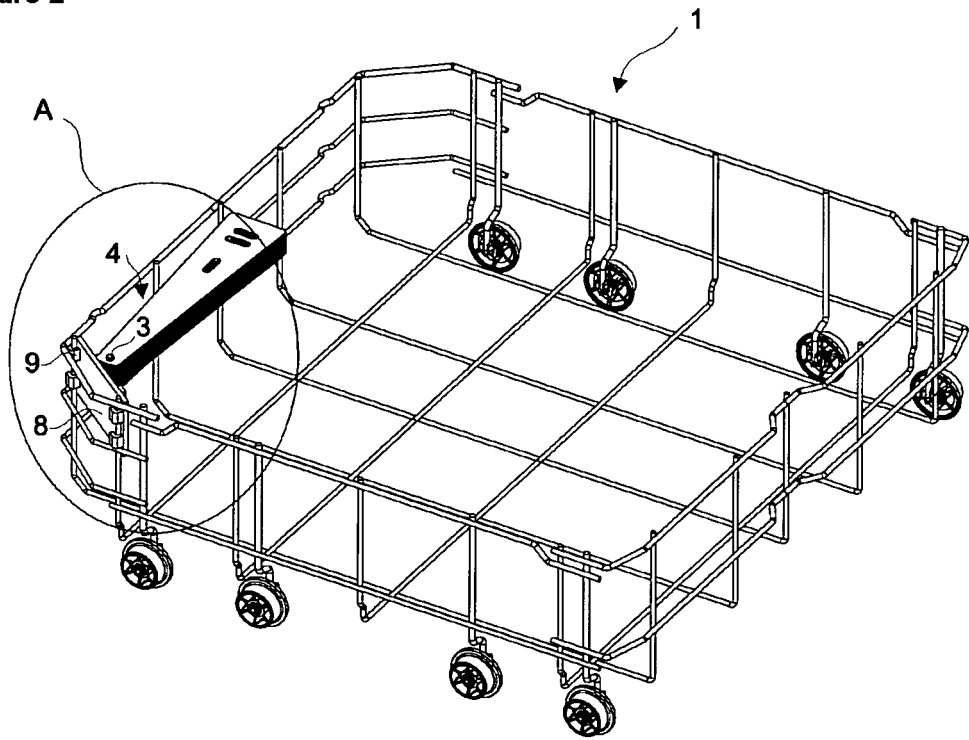

Figure 3

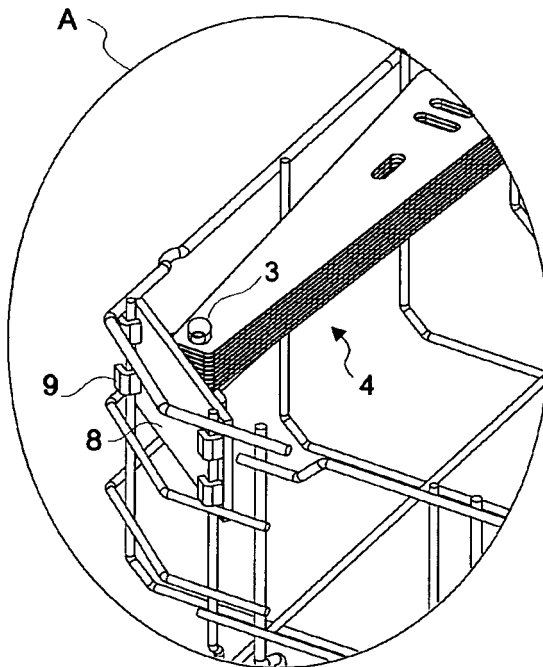
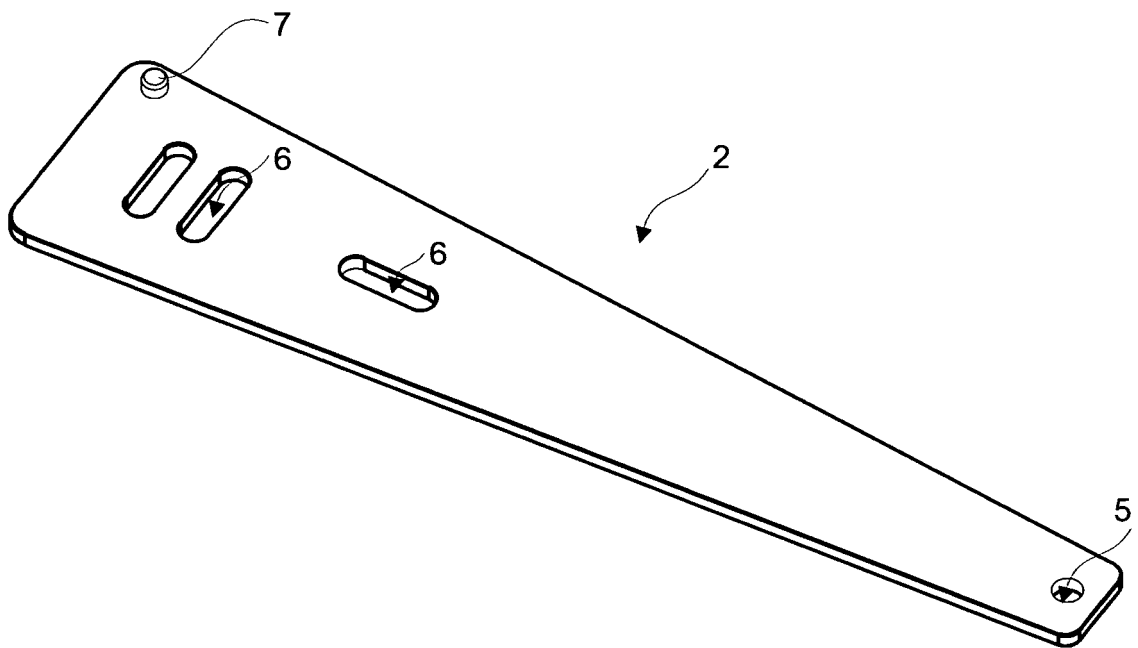

Figure 4



**REFERENCES CITED IN THE DESCRIPTION**

*This list of references cited by the applicant is for the reader's convenience only. It does not form part of the European patent document. Even though great care has been taken in compiling the references, errors or omissions cannot be excluded and the EPO disclaims all liability in this regard.*

**Patent documents cited in the description**

- WO 2011154386 A [0003]
- EP 2283765 A [0004]