



Europäisches Patentamt
European Patent Office
Office européen des brevets



(11) **EP 0 904 721 B1**

(12) **EUROPEAN PATENT SPECIFICATION**

(45) Date of publication and mention
of the grant of the patent:
10.03.2004 Bulletin 2004/11

(51) Int Cl.7: **A47K 3/28**, E05D 15/06

(21) Application number: **98203226.0**

(22) Date of filing: **23.09.1998**

(54) **Shower or sauna booth with sliding door**

Dusch- oder Saunakabine mit Schiebetür

Cabine de douche ou sauna comportant une porte coulissante

(84) Designated Contracting States:
AT DE ES FR GB IT NL

(72) Inventor: **Guzzini, Virgilio**
62019 Recanati (Macerata) (IT)

(30) Priority: **30.09.1997 IT MI970697 U**

(74) Representative: **Eccetto, Mauro**
Studio Torta S.r.l.,
Via Viotti, 9
10121 Torino (IT)

(43) Date of publication of application:
31.03.1999 Bulletin 1999/13

(73) Proprietor: **TEUCO GUZZINI S.p.A.**
62010 Montelupone (IT)

(56) References cited:
WO-A-96/33646 **DE-A- 2 809 404**
US-A- 4 228 560

EP 0 904 721 B1

Note: Within nine months from the publication of the mention of the grant of the European patent, any person may give notice to the European Patent Office of opposition to the European patent granted. Notice of opposition shall be filed in a written reasoned statement. It shall not be deemed to have been filed until the opposition fee has been paid. (Art. 99(1) European Patent Convention).

Description

[0001] The present invention relates to a shower or sauna booth.

[0002] Many booths of this type are usually equipped with a door sliding between an upper suspension track and a lower guide track. The lower guide track is generally made in the form of a metal section track with U cross section and parallel side walls with flat bottom so as to allow the lower edge of the door wing to penetrate into the channel more or less deeply while being guided laterally by the channel. This allows compensation for assembly tolerances and obviates any lack of parallelism between the upper and lower tracks.

[0003] The lower track is however a receptacle for dirt and difficult to clean and, because of the stagnating water therein, often leads to bacterial pollution which could become unacceptable.

[0004] US 4 228 560 describes a door for shower or sauna booth sliding between an upper door-suspension track and a lower door guide track. The lower track identifies a channel for guided sliding of the door and the door comprising, in turn, sliding members with support surfaces sliding on the side walls of the channel.

[0005] The general purpose of the present invention is to obviate the above mentioned drawbacks by making available a booth with sliding door which would have a lower guide preventing stagnation and uncleanable dirt deposits, would offer excellent side guide characteristics for the door and allow the necessary vertical movement of the door.

[0006] In view of said purpose it is sought to provide in accordance with the present invention a booth and in particular for shower or sauna and comprising a door sliding between an upper door suspension track and a lower door guide track with the lower track identifying a channel for guided sliding of the door and the door comprising in turn sliding members with lateral support surfaces sliding on side walls of the channel characterized in that the channel has a curved internal cross section and the lateral support surfaces are elastically movable transversely to the door sliding direction.

[0007] To clarify the explanation of the innovative principles of the present invention and its advantages compared with the prior art there is described below with the aid of the annexed drawings a possible embodiment thereof by way of non-limiting example applying said principles. In the drawings:

- fig.1 shows a diagrammatic front perspective view of a booth in accordance with the present invention,
- fig. 2 shows a partially cross sectioned front view of a sliding detail of the door of the booth of fig. 1,
- figs. 3 and 4 show cross section views along plane of cut III-III of fig. 2 of the sliding member of the door in two different vertical positions inside the guide channel, and
- fig. 5 shows a perspective view of a detail of fig. 2.

[0008] With reference to the figures, fig. 1 shows a booth indicated as a whole by reference number 10 made up of a base 11, a cap 12, side walls 13 and a sliding door 14 made for example of glass. The door slides between an upper suspension track 15 and a lower guide track 16 of the door. The upper track is virtually prior art. For example it could be made from a section of appropriate form on which slide rollers 17 constrained to the upper edge of the door. This track is readily imaginable to those skilled in the art and not further shown or described.

[0009] As may be seen clearly in figs. 2, 3 and 4 the lower track identifies a channel 18 for guided sliding of the door with the door comprising in turn guided sliding members 19 which have support surfaces 20 sliding on the side walls of the channel.

[0010] In accordance with the innovative principles of the present invention the channel 18 has a curved internal cross section e.g. with semicircular bottom so as not to display sharp internal edges. In addition the support surfaces 20 are elastically movable transversely in the door sliding direction.

[0011] In a preferred embodiment the channel 18 is made in a single part with a plate 31 making up the bottom of the booth. To secure high precision in making the channel it has been found advantageous to mold the channel and plate as a single injection-molded part. The guide channel and the sliding members can be masked toward the exterior of the booth by means of a raised edge 32.

[0012] Advantageously the sliding member 19 has a generically overturned U structure to define a pair of elastic arms 21 facing each other across the channel. Each arm ends with a support surface 20 sliding on the nearest side wall of the channel. If the elastic thrust of the arms is considered insufficient there can be provided between the two arms a flat spring 25 to thrust the arms apart. The spring could be restrained with its ends bent within seats 26 in the ends of the arms.

[0013] As may be seen in fig. 5, in a preferred embodiment the sliding member is formed with a first cylindrical part with vertical axis 22 with a coaxial discoid projection 23 near the lower base. The sliding member has a slit 24 in an axial plane of itself which is open on the lower base and closed on the upper base of the cylinder so as to define the pair of elastic arms 21 and the support surface 20 respectively as two facing parts of the cylinder and two facing parts of the discoid projection divided by the slit 24.

[0014] The sliding member 19 is received advantageously in a complementary seat 27 located below in a terminal member 28 of a side section 29 of the door.

[0015] The same seat 27 can constitute a passage for a screw 30 for fastening the terminal member 28 to the section 29. In this manner the sliding member 19 acts as a plug for the seat to preserve the screw from contact with water and moisture.

[0016] From a comparison of figs. 3 and 4 it is seen

that the door can vary the distance to which it penetrates the channel while still being perfectly guided laterally with the slide surfaces of the guide member 19 remaining in contact with the channel walls despite the curved form of the channel.

[0017] It was found that with the curved form of the channel accumulation of dirt difficult to clean and development of bacteria are avoided. Whereas in the prior art it is attempted to obviate the problem of water stagnation in the door-sliding channels by seeking to avoid entry of water therein, with a channel in accordance with the present invention a sliding channel can be used even as a water drainage channel. For this purpose, at one end the channel 18 terminates in a drain 33. Thus all water stagnation is avoided. The absence of sharp edges in the channel eliminates recesses accumulating bacteria and dirt and the channel bottom is easy to clean.

[0018] Naturally the above description of an embodiment applying the innovative principles of the present invention is given by way of non-limiting example of said principles within the scope of the exclusive right claimed here.

[0019] For example the form of the booth and its internal accessories could vary depending on necessity.

Claims

1. Booth and in particular for shower or sauna and comprising a door (14) sliding between an upper door-suspension track (15) and a lower door guide track (16) with the lower track (16) identifying a channel (18) for guided sliding of the door and the door comprising in turn sliding members (19) with lateral support surfaces (20) sliding on side walls of the channel (18) **characterized in that** the channel (18) has a curved internal cross section and the lateral support surfaces (20) are elastically movable transversely to the door sliding direction.
2. Booth in accordance with claim 1 **characterized in that** the sliding member (19) has a generically overturned U structure to define a pair of elastic arms (21) facing each other across the channel with each arm ending with a support surface (20) sliding on the nearest side wall of the channel.
3. Booth in accordance with claim 2 **characterized in that** the sliding member is formed with a first cylindrical part (22) with vertical axis and a coaxial discoid projection (23) near the lower base with the sliding member having a slit (24) in an axial plane of itself which slit is open on the lower base and closed on the upper base of the cylinder so as to define the pair of elastic arms (21) and the support surfaces (20) respectively as two facing parts of the cylinder and two facing parts of the discoid projec-

tion divided by the slit.

4. Booth in accordance with claim 2 **characterized in that** between the two arms (21) is located a flat spring (25) for thrusting the arms apart.
5. Booth in accordance with claim 1 **characterized in that** the sliding member is received in a complementary seat (27) of a terminal member (28) of a side section (29) of the door.
6. Booth in accordance with claim 5 **characterized in that** the seat (27) constitutes a passage for a screw (30) for fastening the terminal member (28) to the section (29).
7. Booth in accordance with claim 1 **characterized in that** the channel (18) is made in a single part with a plate (31) of the booth.
8. Booth in accordance with claim 7 **characterized in that** the plate and channel are a single injection-molded part.
9. Booth in accordance with claim 1 **characterized in that** the bottom of the channel has a circular cross section.
10. Booth in accordance with claim 1 **characterized in that** the channel (18) communicates with a drain (32) to constitute a water drain channel.

Patentansprüche

1. Kabine, insbesondere für Dusche oder Sauna, und umfassend eine Türe (14), die zwischen einer oberen Tür-Hängeschiene bzw. -bahn (15) und einer unteren Tür-Führungsschiene (16) gleitet, wobei die untere Schiene (16) einen Kanal (18) zum geführten Gleiten der Türe aufweist und die Türe wiederum gleitende bzw. Gleitglieder (19) mit seitlichen Abstütz- bzw. Supportoberflächen (20) umfaßt, die an Seitenwänden des Kanals (18) gleiten, **dadurch gekennzeichnet, daß** der Kanal (18) einen gekrümmten inneren Querschnitt aufweist und daß die seitlichen Supportoberflächen (20) elastisch quer zu der Türgleitrichtung bewegbar sind.
2. Kabine nach Anspruch 1, **dadurch gekennzeichnet, daß** das Gleitglied (19) generell eine umgekehrte U-Struktur aufweist, um ein Paar von elastischen Armen (21) zu definieren, die zueinander über den Kanal schauen, wobei jeder Arm mit einer Supportoberfläche (20) endet, die auf der nächsten Seitenwand des Kanals gleitet.
3. Kabine nach Anspruch 2, **dadurch gekennzeichnet,**

net, daß das Gleitglied mit einem ersten zylindrischen Teil (22) mit vertikaler Achse und einem koaxial scheibenförmigen Vorsprung (23) nahe der unteren Basis ausgebildet ist, wobei das Gleitglied einen Schlitz (24) in einer axialen Ebene von sich selbst aufweist, welcher Schlitz auf der unteren Basis offen ist und an der oberen Basis des Zylinders so geschlossen ist, um das Paar von elastischen Armen (21) und die Supportoberflächen (20) jeweils als zwei zueinanderschauende Teile des Zylinders und zwei zueinanderschauende Teile des scheibenförmigen Vorsprungs zu definieren, der durch den Schlitz unterteilt ist.

4. Kabine nach Anspruch 2, **dadurch gekennzeichnet, daß** zwischen den zwei Armen (21) eine flache bzw. Blattfeder (25) zum Drücken bzw. Beaufschlagen der Arme voneinander weg vorgesehen ist.
5. Kabine nach Anspruch 1, **dadurch gekennzeichnet, daß** das Gleitglied in einem komplementären Sitz (27) eines Abschluß- bzw. Endgliedes (28) eines Seitenabschnitts (29) der Türe aufgenommen ist.
6. Kabine nach Anspruch 5, **dadurch gekennzeichnet, daß** der Sitz (27) einen Durchgang für eine Schraube (30) ausbildet, um das Endglied (28) an dem Abschnitt (29) festzulegen.
7. Kabine nach Anspruch 1, **dadurch gekennzeichnet, daß** der Kanal (18) als ein einziger Teil mit einer Platte (31) der Kabine ausgebildet ist.
8. Kabine nach Anspruch 7, **dadurch gekennzeichnet, daß** die Platte und der Kanal ein einstückig spritzgegossenes Teil sind.
9. Kabine nach Anspruch 1, **dadurch gekennzeichnet, daß** der Boden des Kanals einen kreisförmigen Querschnitt aufweist.
10. Kabine nach Anspruch 1, **dadurch gekennzeichnet, daß** der Kanal (18) mit einem Abfluß bzw. Ablauf (32) kommuniziert bzw. in Verbindung steht, um einen Wasserabflußkanal auszubilden.

Revendications

1. Cabine, en particulier pour douche ou sauna, comprenant une porte (14) coulissant entre un rail de suspension de porte supérieur (15) et un rail de guidage de porte inférieur (16), le rail inférieur (16) définissant un canal (18) pour un coulissement guidé de la porte et la porte comprenant à son tour des éléments coulissants (19) comportant des surfaces de maintien latérales (20) coulissant sur les parois

latérales du canal (18), **caractérisée en ce que** le canal (18) a une section transversale interne courbe et les surfaces de maintien latérales (20) sont mobiles de manière élastique transversalement par rapport à la direction de coulissement de la porte.

2. Cabine selon la revendication 1, **caractérisée en ce que** l'élément coulissant (19) a une structure globalement en U inversé pour définir deux bras élastiques (21) se faisant face à travers le canal, chaque bras se terminant par une surface de maintien (20) coulissant sur la paroi latérale du canal la plus proche.
3. Cabine selon la revendication 2, **caractérisée en ce que** l'élément coulissant est constitué d'une première partie cylindrique (22) comportant un axe vertical et d'une saillie discoïde coaxiale (23) près de la base inférieure, l'élément coulissant ayant une fente (24) dans son propre plan axial, laquelle fente est ouverte sur la base inférieure et fermée sur la base supérieure du cylindre de façon à définir respectivement les deux bras élastiques (21) et les surfaces de maintien (20) comme deux parties se faisant face du cylindre et deux parties se faisant face de la saillie discoïde divisée par la fente.
4. Cabine selon la revendication 2, **caractérisée en ce qu'un** ressort plat (25) est situé entre les deux bras (21) pour écarter les bras.
5. Cabine selon la revendication 1, **caractérisée en ce que** l'élément coulissant est reçu dans un siège complémentaire (27) d'un élément terminal (28) d'une partie latérale (29) de la porte.
6. Cabine selon la revendication 5, **caractérisée en ce que** le siège (27) constitue un passage pour une vis (30) destinée à fixer l'élément terminal (28) à la partie (29).
7. Cabine selon la revendication 1, **caractérisée en ce que** le canal (18) est fait d'une pièce avec une plaque (31) de la cabine.
8. Cabine selon la revendication 7, **caractérisée en ce que** la plaque et le canal forment une seule pièce moulée par injection.
9. Cabine selon la revendication 1, **caractérisée en ce que** le fond du canal a une section transversale circulaire.
10. Cabine selon la revendication 1, **caractérisée en ce que** le canal (18) communique avec une évacuation (32) pour constituer un canal d'évacuation d'eau.

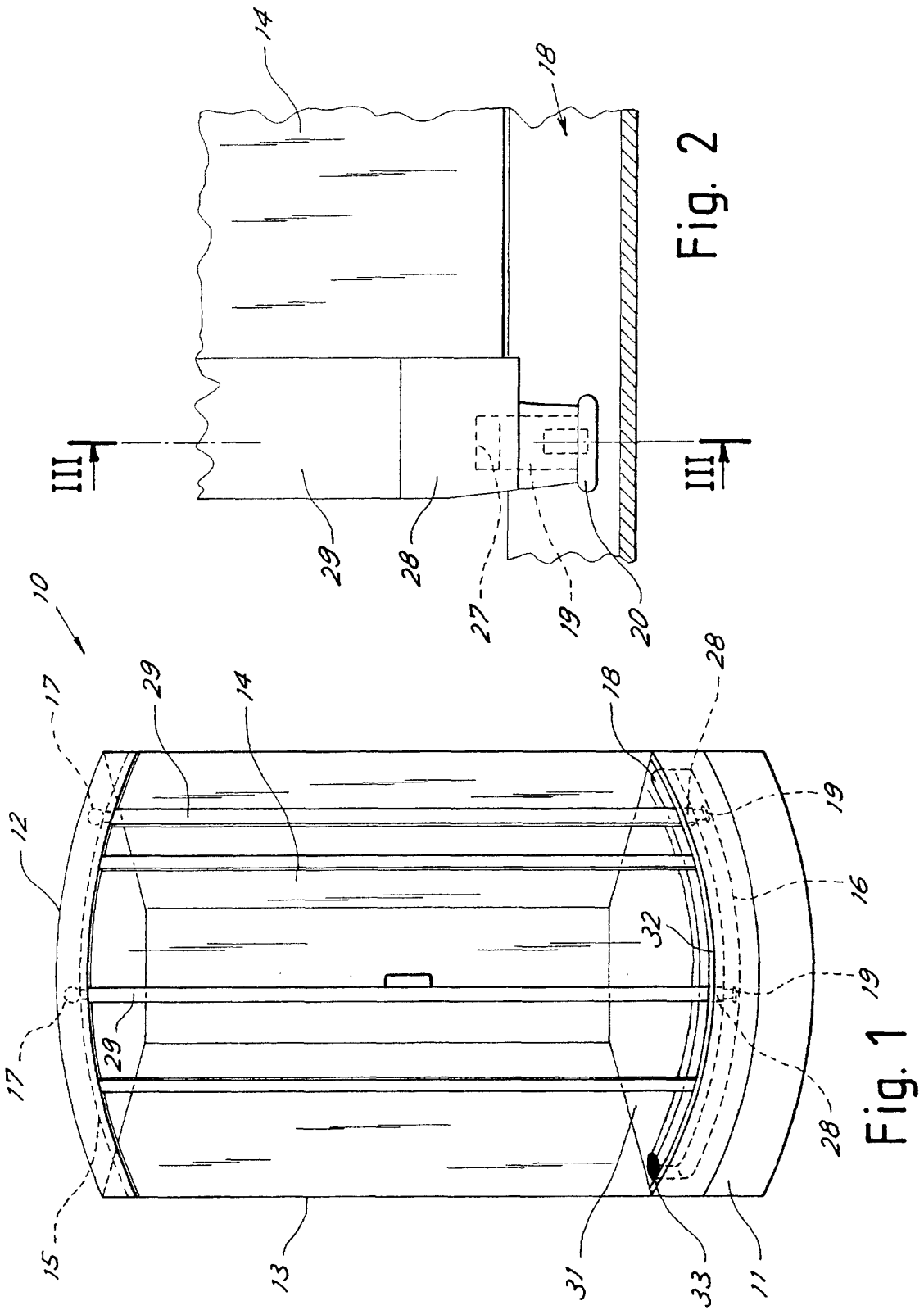

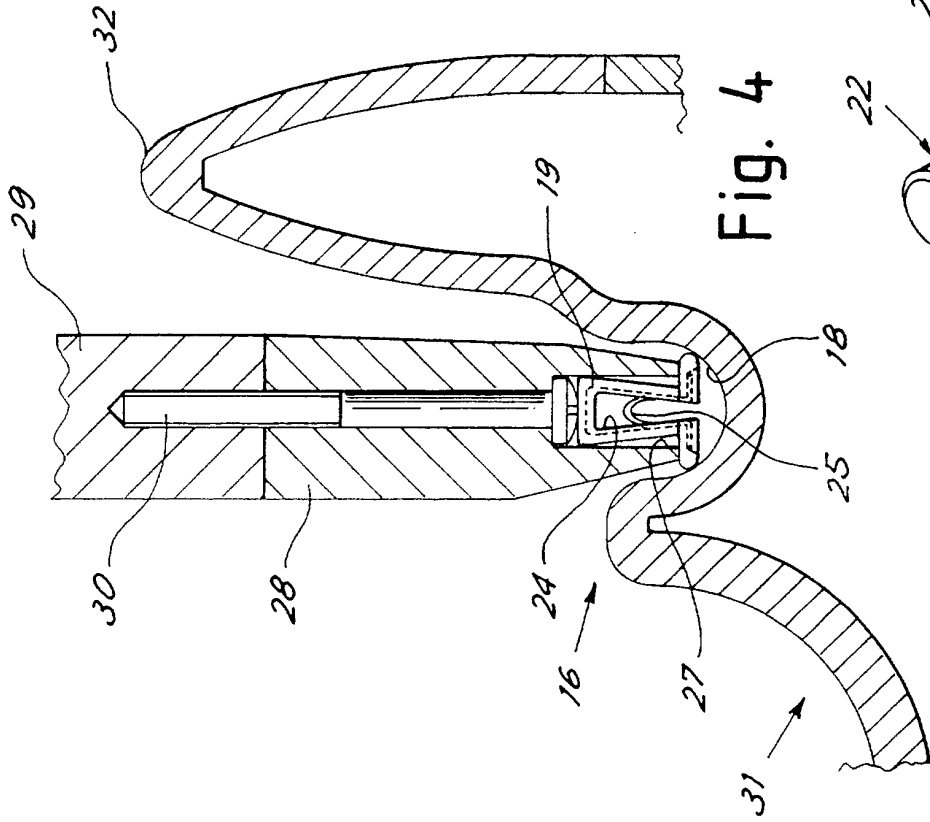

Fig. 4

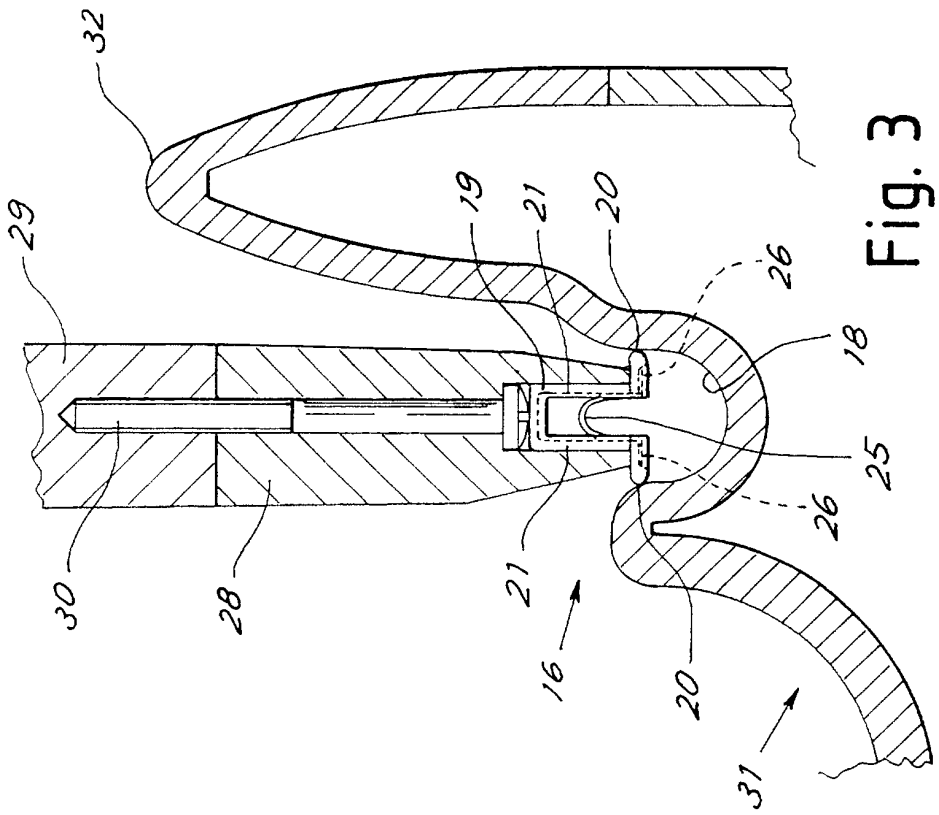

Fig. 3

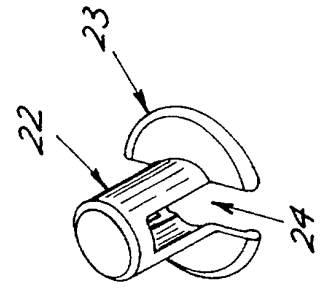

Fig. 5