

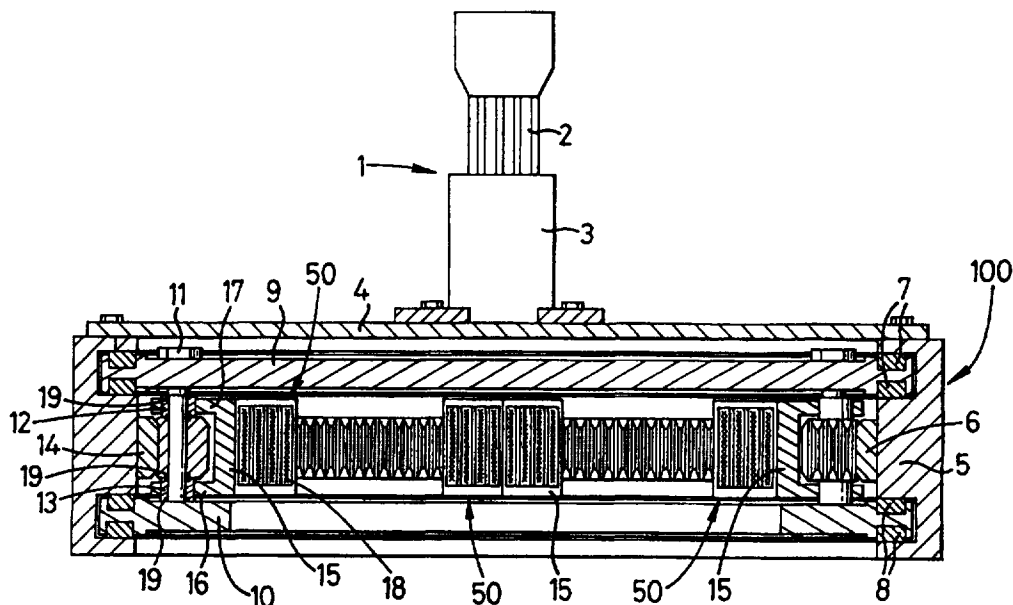

INTERNATIONAL APPLICATION PUBLISHED UNDER THE PATENT COOPERATION TREATY (PCT)

(51) International Patent Classification ⁶ : E21B 19/16	A1	(11) International Publication Number: WO 98/05844 (43) International Publication Date: 12 February 1998 (12.02.98)
<p>(21) International Application Number: PCT/EP97/03568</p> <p>(22) International Filing Date: 7 July 1997 (07.07.97)</p> <p>(30) Priority Data: 9616094.0 31 July 1996 (31.07.96) GB</p> <p>(71) Applicants (for all designated States except US): WEATHER-FORD/LAMB, INC. [US/US]; CSC - The United States Corporation Company, 1013 Centre Road, Wilmington, DE 19805 (US). LUCAS, Brian, Ronald [GB/GB]; Lucas & Co., 135 Westhall Road, Warlingham, Surrey CR6 9HJ (GB).</p> <p>(72) Inventor; and (75) Inventor/Applicant (for US only): STOKKA, Arnold [NO/NO]; Buhagen 8, N-4300 Sandnes (NO).</p> <p>(74) Agent: LUCAS, Brian, Ronald; Lucas & Co., 135 Westhall Road, Warlingham, Surrey CR6 9HJ (GB).</p>	<p>(81) Designated States: AU, CA, CN, JP, NO, US, European patent (AT, BE, CH, DE, DK, ES, FI, FR, GB, GR, IE, IT, LU, MC, NL, PT, SE).</p> <p>Published <i>With international search report.</i></p>	

(54) Title: MECHANISM FOR CONNECTING AND DISCONNECTING TUBULARS



(57) Abstract

A top drive is used to connect successive lengths of casing. The casing is gripped by a mechanism (100) which comprises a support (5) which is attached to the top drive by a drive plate (4). A circular plate (9) is rotatably mounted in the support (5) and is associated with four jaw assemblies (50). In use the mechanism (100) is lowered onto a length of casing until the circular plate (9) engages the top of the casing. When the top drive is rotated in one sense the support (5) rotates relative to the circular plate (9). This causes toothed cylinders (14) to rotate which, in turn, rotates eccentric members (12 and 13) which advance the jaws (15) into gripping engagement with the casing. Further rotation of the top drive rotates the casing and screws it into the casing below.

FOR THE PURPOSES OF INFORMATION ONLY

Codes used to identify States party to the PCT on the front pages of pamphlets publishing international applications under the PCT.

AL	Albania	ES	Spain	LS	Lesotho	SI	Slovenia
AM	Armenia	FI	Finland	LT	Lithuania	SK	Slovakia
AT	Austria	FR	France	LU	Luxembourg	SN	Senegal
AU	Australia	GA	Gabon	LV	Latvia	SZ	Swaziland
AZ	Azerbaijan	GB	United Kingdom	MC	Monaco	TD	Chad
BA	Bosnia and Herzegovina	GE	Georgia	MD	Republic of Moldova	TG	Togo
BB	Barbados	GH	Ghana	MG	Madagascar	TJ	Tajikistan
BE	Belgium	GN	Guinea	MK	The former Yugoslav Republic of Macedonia	TM	Turkmenistan
BF	Burkina Faso	GR	Greece	ML	Mali	TR	Turkey
BG	Bulgaria	HU	Hungary	MN	Mongolia	TT	Trinidad and Tobago
BJ	Benin	IE	Ireland	MR	Mauritania	UA	Ukraine
BR	Brazil	IL	Israel	MW	Malawi	UG	Uganda
BY	Belarus	IS	Iceland	MX	Mexico	US	United States of America
CA	Canada	IT	Italy	NE	Niger	UZ	Uzbekistan
CF	Central African Republic	JP	Japan	NL	Netherlands	VN	Viet Nam
CG	Congo	KE	Kenya	NO	Norway	YU	Yugoslavia
CH	Switzerland	KG	Kyrgyzstan	NZ	New Zealand	ZW	Zimbabwe
CI	Côte d'Ivoire	KP	Democratic People's Republic of Korea	PL	Poland		
CM	Cameroon	KR	Republic of Korea	PT	Portugal		
CN	China	KZ	Kazakstan	RO	Romania		
CU	Cuba	LC	Saint Lucia	RU	Russian Federation		
CZ	Czech Republic	LI	Liechtenstein	SD	Sudan		
DE	Germany	LK	Sri Lanka	SE	Sweden		
DK	Denmark	LR	Liberia	SG	Singapore		
EE	Estonia						

Mechanism for Connecting and Disconnecting Tubulars

This invention relates to a mechanism for connecting and disconnecting tubulars, to a top drive provided with such a mechanism, and to a method of running casing using said mechanism and/or top drive.

During the construction of oil and gas wells a hole is bored into the earth. Lengths of casing are then screwed together to form stands and lowered into the bore, inter alia to prevent the wall of the bore collapsing and to carry oil or gas to the surface.

After each stand of casing has been lowered into the bore slips are applied which support the casing whilst the next stand of casing is screwed into the casing in the slips. When the new stand of casing is connected to the casing in the slips the slips are released and the new stand lowered into the bore. This process is repeated until the desired length of casing has been lowered into the bore. In certain operations a stand of casing may comprise a single tubular.

It is important that the joints between the lengths of casing are tightened to the correct torque both to render the joint leakproof and to ensure that the casing will not part.

Historically, lengths of casing were originally connected using manually operated tongs. Later these were replaced by power operated tongs which were manoeuvred into position manually. More recently automatic tongs have been introduced which run on rails and can be advanced towards a joint or withdrawn therefrom by remote control.

Whilst power tongs have proved satisfactory for use with standard casing having a diameter up to 41cm (16 inches), it is now becoming more common to employ casing with a diameter of from 47cm (18 5/8") to 92cm (36").

Although automatic tongs have been built to

- 2 -

accommodate such casing they are extremely heavy and extremely expensive.

One apparatus for rotating a drill string during drilling is known as a top drive. Top drives are generally hydraulically or electrically operated.

PCT Publication WO 96/18799 in one aspect discloses a method for connecting tubulars, which method comprises the step of rotating one tubular relative to another with a top drive. Also disclosed is an apparatus which comprises a head for gripping a length of casing and a drive shaft which extends from said head and is rotatable by a top drive.

The present invention provides a mechanism which facilitates gripping the casing.

According to one aspect of the present invention there is provided a mechanism for gripping a tubular, which mechanism comprises at least one jaw movable into engagement with said tubular, characterised in that said mechanism further comprises a support connectable to a top drive and rotatable thereby, a plate rotatable relative to said support, and means responsive to relative rotation between said support and said plate to displace said at least one jaw, the arrangement being such that, in use, when said mechanism is lowered onto a tubular, said plate engages said tubular whereafter rotation of said support in one sense creates relative rotation between said support and said plate and causes said at least one jaw to move into gripping engagement with said tubular.

Preferably, said means comprises a cylinder which engages said support and is rotatably mounted on said plate, and an eccentric member fast with said cylinder.

Advantageously, said cylinder is toothed and said support comprises a toothed track which meshes therewith.

The present invention also provides a top drive having a mechanism in accordance with the present invention attached thereto.

The present invention also provides a method of
5 running casing, which method comprises the steps of joining said casing using a mechanism or a top drive in accordance with the present invention.

10

15

20

25

30

35

- 4 -

For a better understanding of the invention reference will now be made, by way of example, to the accompanying drawings in which:

Figure 1 is a side view, partly in cross-section, of one embodiment of a mechanism in accordance with the present invention; and

Figure 2 is a schematic top plan view of a part of the mechanism shown in Figure 1.

Referring to Figure 1, there is shown a mechanism for gripping tubulars which is generally identified by the reference numeral 100. The mechanism 100 depends from a top drive (not shown) by a telescopic drive shaft 1. The telescopic drive shaft 1 comprises an upper section 2 and a lower section 3 which are provided with interengaging external and internal splines respectively.

The lower section 3 is bolted to the mechanism 100 via a drive plate 4.

The mechanism 100 comprises an annular support 5 which is bolted to the drive plate 4. A toothed track 6 is provided on the inner surface of the annular support 5 and forms part thereof. The annular support 5 is also provided with upper bearings 7 and lower bearings 8. The upper bearings 7 support a circular rotatable plate 9 whilst the lower bearings 8 support a rotatable ring 10. The circular rotatable plate 9 is bolted to the rotatable ring 10 by long bolts 11.

The mechanism 100 includes four jaw arrangements 50. Each jaw arrangement 50 comprises an upper eccentric member 12 and a lower eccentric member 13 both of which are mounted fast on a toothed cylinder 14. The upper and lower eccentric members 12, 13 and the toothed cylinder 14 are rotatably mounted on long bolt 11 by bearings 19. If desired, the toothed cylinder 14 and the upper and lower members 12, 13 could be machined

from one piece of material.

Jaws 15 are provided with an upper lug 17 and a lower lug 16 which are each provided with holes which encircle the upper and lower eccentric members 12, 13
5 respectively.

The jaw arrangements 50 are spaced at 90° around the circular rotatable plate 9. The jaws 15 also comprise teeth 18 to facilitate gripping.

In use, the mechanism 100 is lowered over the top
10 of a stand of casing (which may comprise one or more lengths of casing) to be gripped, until the rotatable plate 9 engages the top of the casing. The upper section of the casing is now surrounded by the four jaw arrangements 50. The top drive (not shown) now rotates
15 the drive plate 4 which is bolted to the annular support 5. Due to friction between the rotatable plate 9 and the top of the casing to be gripped, the rotatable plate 9 remains stationary. The toothed track 6 rotates with the drive plate 4. This movement causes the toothed
20 cylinder 14 to rotate about the long bolt 11. The upper and lower eccentric members 12, 13 rotate about the long bolt 11 and hence push the jaws 15 and teeth 18 inwardly to grip the outer surface of the casing.

The stand of casing can now be screwed into a
25 string of casing to a required torque. During this step the rotatable plate 9 rotates with the top drive, drive plate 4 and the stand of casing.

After the stand of casing has been tightened to the required torque the main elevator (not shown) is applied
30 to the stand of casing as described in WO-A-96/18799.

For release of the mechanism the top drive (not shown) rotates the drive plate 4 anti-clockwise. The annular member 5 and the toothed track 6 rotate with the drive plate 4 and this movement rotates the toothed
35 cylinder 14 about the long bolt 11. The upper and lower

- 6 -

eccentric members 12,13 rotate with the toothed cylinder about the long bolt 11 and pull the jaws 15 outwardly, releasing the teeth 18 from the outer surface of the casing. The top head drive (not shown) and the mechanism
5 can now be raised away from the stand of casing.

It should be noted that the main elevator (not shown) is attached to the upper length of casing of the stand of casing before release of the mechanism. This is important as any anti clockwise torque applied to the
10 casing during release of the mechanism is transferred to the main elevator and not through the casing string, which could reduce the torque on a connection.

Various modifications to the preferred embodiment described are envisaged. For example, the plate 9 may
15 comprise a disc (as shown), an annulus, or even one or more segments against which the casing can abut. The lower surface of the plate 9 may be roughened or provided with friction material if desired.

Mechanisms in accordance with the present invention
20 are particularly intended for running casing with a diameter greater than 41cm (16 inches) and, more particularly, greater than 60cm (24 inches). They are particularly useful with very large casing having a diameter equal to or greater than 90cm (36 inches).

25

30

35

CLAIMS

1. A mechanism for gripping a tubular, which mechanism comprises at least one jaw (50) movable into engagement with said tubular, characterised in that said mechanism
5 further comprises a support (5) connectable to a top drive and rotatable thereby, a plate (9) rotatable relative to said support (5), and means responsive to relative rotation between said support (5) and said plate (9) to displace said at least one jaw (50), the
10 arrangement being such that, in use, when said mechanism is lowered onto a tubular, said plate (9) engages said tubular whereafter rotation of said support (5) in one sense creates relative rotation between said support (5) and said plate (9) and causes said at least one jaw (50)
15 to move into gripping engagement with said tubular.
2. A mechanism as claimed in Claim 1, characterised in that said means comprises a cylinder (14) which engages said support (5) and is rotatably mounted on said plate (9), and an eccentric member (12, 13) fast with said
20 cylinder (14).
3. A mechanism as claimed in Claim 2, wherein said cylinder (14) is toothed and said support (5) comprises a toothed track (6) which meshes therewith.
4. A top drive having a mechanism as claimed in Claim
25 1, 2 or 3, attached thereto.
5. A method of running casing, which method comprises the step of joining said casing using a mechanism as claimed in Claim 1, 2 or 3, or a top drive as claimed in
Claim 4.

30

35

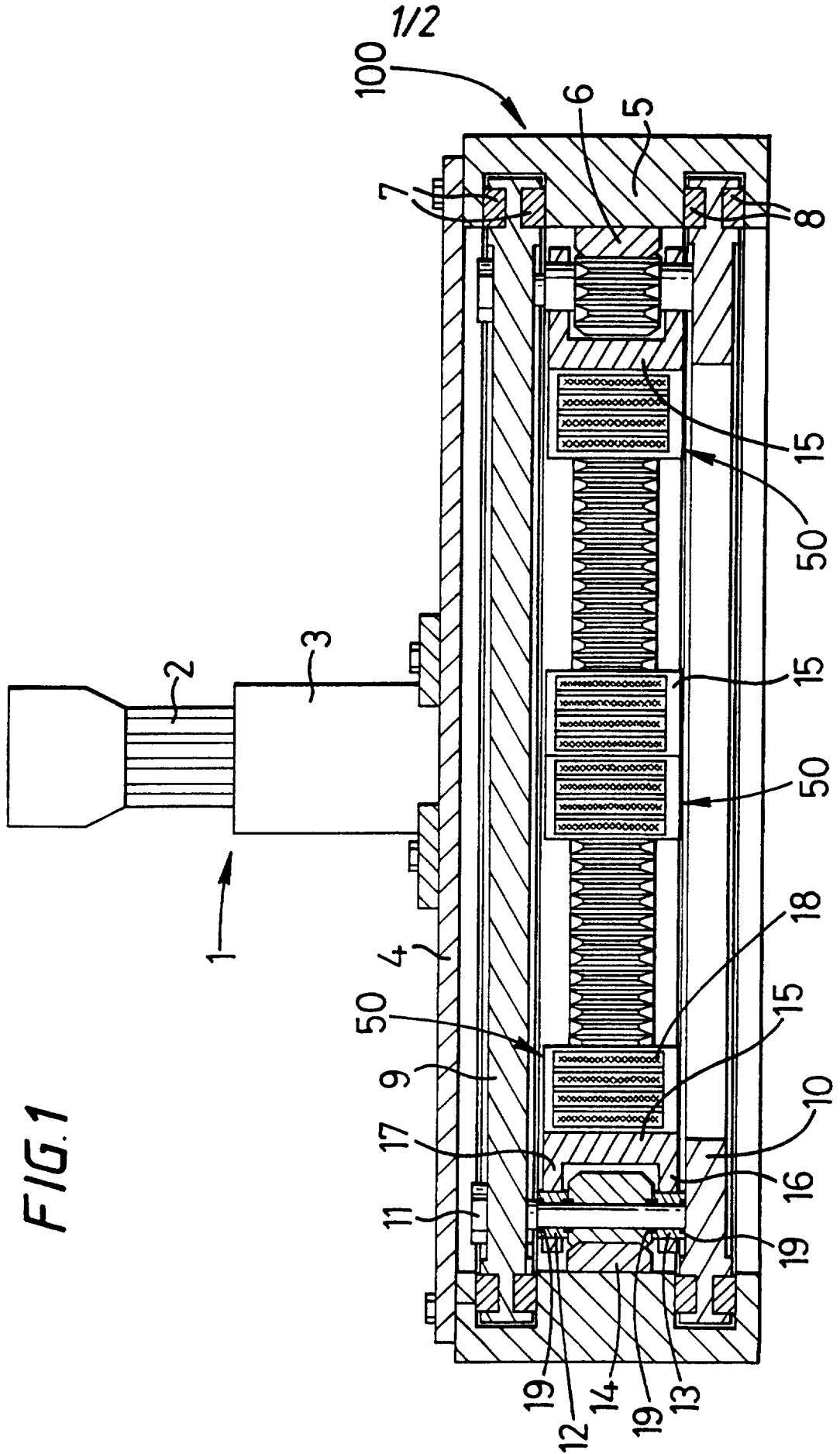
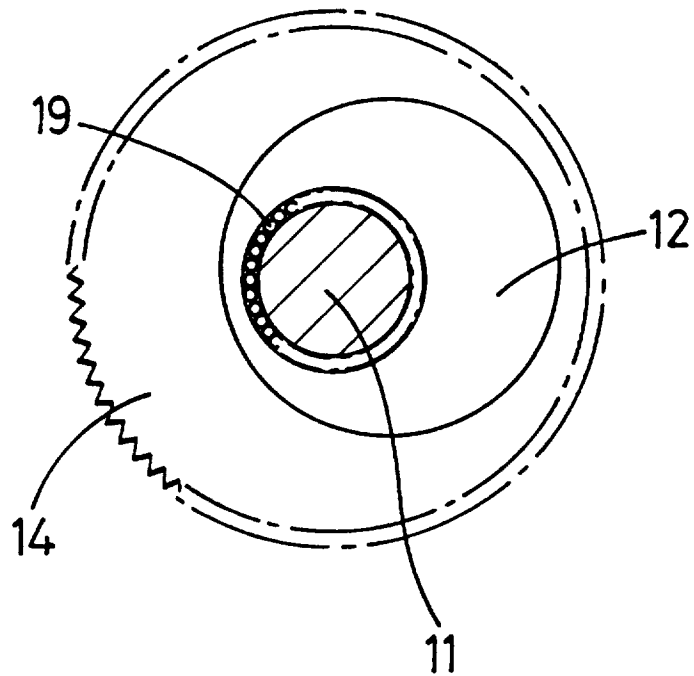

FIG. 2



INTERNATIONAL SEARCH REPORT

Internat. Application No
PCT/EP 97/03568

A. CLASSIFICATION OF SUBJECT MATTER
IPC 6 E21B19/16

According to International Patent Classification (IPC) or to both national classification and IPC

B. FIELDS SEARCHED

Minimum documentation searched (classification system followed by classification symbols)
IPC 6 E21B B25B

Documentation searched other than minimum documentation to the extent that such documents are included in the fields searched

Electronic data base consulted during the international search (name of data base and, where practical, search terms used)

C. DOCUMENTS CONSIDERED TO BE RELEVANT

Category *	Citation of document, with indication, where appropriate, of the relevant passages	Relevant to claim No.
X	DE 21 31 732 A (INTERMEDIUM) 11 January 1973	1-4
Y	see page 3, paragraph 2 - page 4, paragraph 2; figures 1-5	5
Y	---	
Y	US 5 036 927 A (C.A. WILLIS) 6 August 1991 see column 2, line 48 - column 4, line 46	5
A	see figures 1,2	1,4
A	---	
A	EP 0 311 455 A (W-N APACHE) 12 April 1989 see abstract; figures 1-6	1,4,5
A	---	
A	WO 96 18799 A (WEATHERFORD/LAMB) 20 June 1996 cited in the application see figures 1,3	1,4,5

	-/--	

Further documents are listed in the continuation of box C.

Patent family members are listed in annex.

* Special categories of cited documents :

- *A* document defining the general state of the art which is not considered to be of particular relevance
- *E* earlier document but published on or after the international filing date
- *L* document which may throw doubts on priority claim(s) or which is cited to establish the publication date of another citation or other special reason (as specified)
- *O* document referring to an oral disclosure, use, exhibition or other means
- *P* document published prior to the international filing date but later than the priority date claimed

- *T* later document published after the international filing date or priority date and not in conflict with the application but cited to understand the principle or theory underlying the invention
- *X* document of particular relevance; the claimed invention cannot be considered novel or cannot be considered to involve an inventive step when the document is taken alone
- *Y* document of particular relevance; the claimed invention cannot be considered to involve an inventive step when the document is combined with one or more other such documents, such combination being obvious to a person skilled in the art.
- *&* document member of the same patent family

Date of the actual completion of the international search

27 October 1997

Date of mailing of the international search report

03.11.97

Name and mailing address of the ISA

European Patent Office, P.B. 5818 Patentlaan 2
NL - 2280 HV Rijswijk
Tel. (+31-70) 340-2040, Tx. 31 651 epo nl,
Fax: (+31-70) 340-3016

Authorized officer

Leitner, J

INTERNATIONAL SEARCH REPORT

Intern. Application No
PCT/EP 97/03568

C.(Continuation) DOCUMENTS CONSIDERED TO BE RELEVANT

Category *	Citation of document, with indication, where appropriate, of the relevant passages	Relevant to claim No.
A	G.F. HAYES: "WRENCH ADAPTER" IBM TECHNICAL DISCLOSURE BULLETIN, vol. 17, no. 4, September 1974, pages 985-986, XP002044669 -----	

INTERNATIONAL SEARCH REPORT

International Application No
PCT/EP 97/03568

Patent document cited in search report	Publication date	Patent family member(s)	Publication date
DE 2131732 A	11-01-73	NONE	
US 5036927 A	06-08-91	EP 0525247 A	03-02-93
EP 311455 A	12-04-89	US 4867236 A	19-09-89
WO 9618799 A	20-06-96	AU 4266796 A	03-07-96