

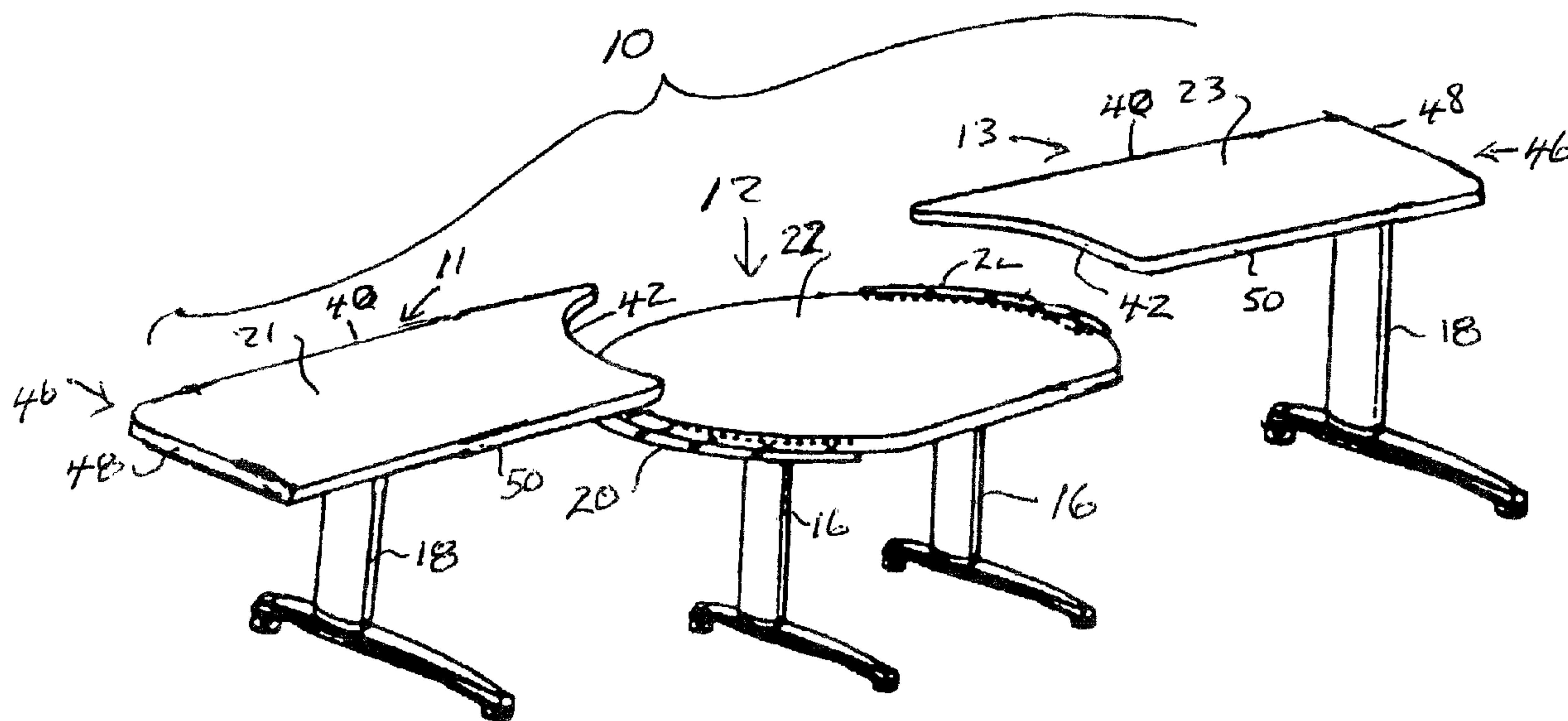

(22) Date de dépôt/Filing Date: 2003/07/31  
(41) Mise à la disp. pub./Open to Public Insp.: 2005/01/31

(51) Cl.Int.<sup>7</sup>/Int.Cl.<sup>7</sup> A47B 87/00  
(71) Demandeur/Applicant:  
INSCAPE CORPORATION, CA  
(72) Inventeur/Inventor:  
WASLEY, TIM, CA  
(74) Agent: RICHES, MCKENZIE & HERBERT LLP

(54) Titre : TABLE A RALLONGES A ALIGNEMENT VARIABLE  
(54) Title: VARIABLE ANGLE WINGED TABLE



(57) Abrégé/Abstract:

A corner table with two wing tables which is adapted to form a symmetrical arrangement with the wing tables disposed at different angles. The novel table assembly in accordance with the present invention preferably is used in combination with walls disposed at angles which may vary from each other and with the corner table and its wing tables to be complementarily received in whatever angle may be formed by the walls.

**ABSTRACT**

**A corner table with two wing tables which is adapted to form a symmetrical arrangement with the wing tables disposed at different angles. The novel table assembly in accordance with the present invention preferably is used in combination with walls disposed at angles which may vary from each other and with the corner table and its wing tables to be complementarily received in whatever angle may be formed by the walls.**

Title

## **VARIABLE ANGLE WINGED TABLE**

Scope of the Invention

**[0001]** This invention relates to a corner table and, more particularly, to a table adapted to be used in a corner configuration with two wing tables on either side.

Background of the Invention

**[0002]** Corner tables are known in which the corner table is adapted to be used in a corner configuration having particular angles. Thus, a known corner table is provided with wing tables extending from each side and are provided to match a particular angled corner. Typical configurations are thus customized for a 90° angle corner or a 120° angle corner.

**[0003]** A disadvantage of previously known corner tables with wing tables is that they are not adapted such that the same corner table and wing tables may be used in corners of different angles.

Summary of the Invention

**[0004]** To at least partially overcome these disadvantages of previously known tables, the present invention provides a corner table with two wing tables which is adapted to form a symmetrical arrangement with the wing tables disposed at different angles. The novel table assembly in accordance with the present invention preferably is used in combination with walls disposed at angles which may vary from each other and with the corner table and its wing tables to be complementarily received in whatever angle may be formed by the walls.

**[0005]** An object of the present invention is to provide a construction for a corner table including two wing tables, one on either side thereof.

**[0006]** Another object is to provide an improved corner table with two wing tables adapted to be used at a junction of walls which are disposed at varying angles to each other.

- [0007] Accordingly, in one aspect, the present invention provides a desk assembly comprising:
- [0008] a center desktop and two extension wing desktops,
- [0009] the center desktop supported on a suitable leg assembly and defining a center desk top surface,
- [0010] the peripheral shape of the center desktop is a segment of a circle bounded by a convex edge comprising an arc of a first constant radius and by a chord edge comprising a chord of the circle,
- [0011] the convex edge having a first end point and a second end point, the arc extending about a center point of the circle centered on the center desktop through an included angle of at least 210 degrees from the first end point to the second point,
- [0012] the chord edge extending from the first end point to the second end point,
- [0013] the two extension wing desktops comprising a right-hand wing desktop and a left-hand wing desktop each having a wing desktop surface,
- [0014] the two extension wing desktops connectable to the center desktop with the wing desktop surfaces forming a continuing surface with the center desktop surface,
- [0015] the peripheral shape of each wing desktop includes a straight rear edge adjacent a concave end edge formed as a concave arc of constant radius equal to the first radius,
- [0016] each concave end edge adapted to mate with the convex edge of the center desktop such that, with the concave end edge of the right-hand wing desktop on the convex edge on the right-hand side of the chord edge and the concave end edge of the left-hand wing desktop wing top on the convex edge on the left-hand side of the chord edge, the right and left-hand wing desktops are attachable to the center desktop in a plurality of different angular positions relative to the center point and therefore relative to each other,
- [0017] the different angular positions including:
- [0018] a straight position in which the rear edge of the right-hand wing desktop and the rear edge of the left-hand wing desktop lie in a straight line, and

[0019] a right-angled position in which the rear edge of the right-hand wing desktop and rear edge of the left-hand wing desktop are normal to each other.

#### Brief Description of the Drawings

[0020] Further aspects and advantages of the present invention will become apparent from the following description taken together with the accompanying drawings in which:

[0021] Figure 1 is a schematic exploded view of a corner table or desk assembly in accordance with a first embodiment of the present embodiment;

[0022] Figure 2 is a bottom view of the table in Figure 1, however, arranged in a 90° configuration;

[0023] Figure 3 is a top view of the table shown in Figure 1 in a right angled configuration;

[0024] Figure 4 is a top view of the table shown in Figure 1 in a 120° configuration;

[0025] Figure 5 is a top view of the table shown in Figure 1 in a 180° configuration;

[0026] Figure 6 is an exploded pictorial view similar to that of Figure 1, however, showing a table assembly in accordance with a second embodiment of the present invention;

[0027] Figure 7 is a top view showing a plurality of tables of Figure 1 illustrated in a right angled configuration in conjunction with a plurality of wall partitions disposed at 90° orientations;

[0028] Figure 8 is a top view showing a plurality of tables of Figure 1 illustrated in a right angled configuration in conjunction with a plurality of wall partitions disposed at 120° orientations;

[0029] Figure 9 is a top view showing a plurality of tables of Figure 1 illustrated in a right angled configuration in conjunction with a plurality of wall partitions disposed at 120° orientations;

[0030] Figure 10 is a pictorial view of a table assembly in accordance with a third embodiment in conjunction with a workstation formed from a plurality of wall partitions.

### Detailed Description of the Drawings

**[0031]** Reference is made first to Figures 1 and 2 showing a desk assembly 10 in accordance with the first preferred embodiment of this invention. The desk assembly 10 includes a center desk 12 and two wing desks, left wing desk 11 and right wing desk 13.

**[0032]** The center desk 12 has a center desktop 22 which is supported on a suitable leg assembly comprising two L-shaped legs 16 secured to the underside of the center desktop 14 as best seen in Figure 2. Also secured to the under surface of the center desktop are two support brackets 20 and 24 which provide a support ledge extending laterally from the center desktop 14 on each side thereof which brackets are adapted to receive and support thereon a concave end edge 42 of each of the left and right wing desks. As seen in Figure 1, the distal ends of the wing desks 11 and 13 are supported spaced from the center desk on respective L-shaped legs 18.

**[0033]** Figure 2 shows the desk assembly 10 of Figure 1 from a bottom view in an assembled condition oriented in a 90° position. Figure 3 shows the desk of Figure 2 in top view.

**[0034]** The peripheral shape of the center desktop 72 is a segment of a circle about center point 30 as bounded by a convex edge 32 and a cord edge 34. The convex edge 32 comprises an arc of a constant radius from the center 30. The convex edge 32 extends from a first end point 36 to a second end point 38. The cord edge 34 comprises a cord of the circle and extends from the first end point 36 to the second end point 38 preferably as a substantially straight line.

**[0035]** The right-hand wing desk 13 has a right-hand wing desktop 23 and the left-hand wing desk has a left-hand wing desktop 21. The peripheral shape of each wing desktop includes a straight rear edge 40 adjacent a concave end edge 42. The concave end edge 42 is formed as a concave arc of a constant radius equal to the radius which forms the segment of the circle comprising convex edge 32. Each concave end edge 42 is adapted to mate with the convex edge 32 of the center desktop 22 such that with the concave end edge 42 of the right-hand wing desktop 23 on the convex edge of the right-hand side of the cord edge 34 and the concave end edge 42 of the left-hand wing desktop

21 on the convex edge 32 of the left-hand side of the cord edge 34, the right and left-hand wing desktops are attachable to the center desktop 22 in a plurality of different angular positions relative to the center point 30 and, therefore, relative to each other. Different angular orientations illustrated include: as shown in Figure 3, a right-angled position in which the rear edge 40 of the right-hand wing desk 13 and the rear edge 40 of the left-hand wing desk are normal to each other as seen in Figures 2 and 3; and, a straight position in which the rear edge 40 of the right-hand wing desk 13 and the rear edge 40 of the left-hand wing desk 11 lie in a straight line as seen in Figure 5.

[0036] The different angular positions which the wing desks may assume relative to the center desktop include intermediate angled positions between the right angled position of Figure 3 and the straight position of Figure 5. The intermediate angled positions include a 120° position as shown in Figure 4 in which the rear edge 40 of the right-hand wing desk 13 and the rear edge 40 of the left-hand wing desk 11 are disposed to form an angle of 180° between them.

[0037] The center desktop 22 has a center desktop surface and each of the left and right wing desktops have their own wing desktop surface. The two wing desktops 21 and 23 are connectable to the center desktop 22 such that the wing desktop surfaces form a continuing surface with the center desktop surface.

[0038] As is apparent particularly from Figures 3 to 5, in the preferred embodiment, the left-hand wing desktop 21 and the right-hand wing desktop 23 are mirror images of each other.

[0039] Each wing desktop has the straight rear edge 40 and a concave end edge 42. The peripheral shape of each wing desktop is elongate extending away from the concave end edge 42 to a distal end 46 having a distal end edge 48 opposite to the concave end edge 42. The peripheral shape of each wing desktop includes a front edge 50 opposite to the rear edge 40. Each of the concave end edge 42 and the distal end edge 48 span between the rear edge 40 and the front edge 50. In the preferred embodiment shown, the front edge 50 is straight and parallel to the rear edge 40 and the distal end edge 52 is normal to the rear edge 40.

**[0040]** In the preferred embodiment shown, the convex edge 32 of the center desktop 22 extends through an included angle A. In the preferred embodiment, the included angle is about  $290^\circ$ , the radius from the center 30 to the convex edge 32 is indicated as R. The width W of each wing desktop from the rear edge 40 to the front edge 50 is about 90% R. The length of the cord edge 34 from first end point 36 to second end point 38 is approximately equal to the width W of the wing desktops.

**[0041]** Reference is made to Figure 6 which shows a second embodiment of a desk assembly which is substantially identical to the desk assembly 10 shown in Figure 1 and differs merely in the fact that each of the two wing tables 11 and 13 have a suitable leg assembly such that they are independently supported as seen on two L-shaped legs 18 and may be freely movable upon a floor to assume desired angular orientations about the center desktop 12. In Figure 6, the wing desks are shown in an exploded view spaced from the center desk, however, it is to be appreciated that in use, the desks are to be arranged as to assume positions in angular orientations as shown, for example, in Figures 3 to 5.

**[0042]** Reference is now made to Figures 7, 8 and 9 which illustrate the desk assembly 10 illustrated in Figures 1 to 6 as used in combination with a plurality of vertically disposed walls formed from planar screen panels 70. Such planar screen panels 70 are well known as, for example, disclosed in various U.S. patents such as U.S. Patent 6,286,275 to Edwards, issued September 11, 2001 and in U.S. Patent 5,784,843 to Greer et al, issued July 28, 1998 and U.S. Patent 6,134,844 to Cornell et al, issued October 24, 2000.

**[0043]** Reference is again made to Figures 7, 8 and 9 which illustrate a plurality of vertically disposed planar screen panels 70 forming walls to define workspaces with a desk assembly 10 in accordance with the present invention provided in various of the corners provided between different screen panels 70.

**[0044]** Referring to Figure 7, the various panels 70 are disposed at  $90^\circ$  to each other. That is, as between a first panel 70a and a second panel 70b, an included angle is provided of  $90^\circ$ . A desk assembly in accordance with the present invention is located in

the included angle between the first and second panels with the right-hand panel 70c located adjacent the rear edge of the right-hand wing desk 13 extending parallel thereto and the left-hand panel 70b located adjacent the rear edge of the left-hand wing desk extending parallel thereto.

[0045] Reference is made to Figure 8 which shows a plurality of panels 70 each disposed so as to form an included angle between each of  $120^\circ$ . Three desk assemblies 10 in accordance with the present invention are shown being provided in the corners between each two adjacent panels in each case with the straight rear edges of the left and right wing desks being disposed adjacent and parallel to their respective panels.

[0046] Figure 9 illustrates a condition in which the panels 70 are disposed in a zigzag manner with each adjacent panel 70 forming an included angle of about  $120^\circ$  with its adjacent panel. A desk assembly 10 in accordance with the present invention is provided in the corners formed between adjacent panels which corners form an included angle of about  $120^\circ$ .

[0047] While each of Figures 7, 8 and 9 illustrate configurations for the panels which adopt the same included angle throughout in each configuration, this is not necessary and each of the panel structures shown in Figures 7, 8 and 9 could be joined to the other. It is also not necessary that merely included angles of  $90^\circ$ ,  $120^\circ$  or  $180^\circ$  be utilized. In accordance with the present invention, the desk assembly is able to accommodate any included angles between panels of between  $90^\circ$  and  $180^\circ$ . This is advantageous when customizing the relative location of the panels in the desk assemblies and is to be appreciated that the desk assembly in accordance with the present invention is particularly adapted for use with free-standing movable planar screen panels which can be coupled at their ends to each other in a manner that the panels can assume any angle between  $90^\circ$  and  $180^\circ$ . Of course, insofar as the walls are to be built permanently, then the walls may be built permanently to have any included angle formed therebetween.

[0048] Reference is made to Figure 10 which illustrates a workplace wall system substantially the same as that disclosed in U.S. Patent 6,286,275 to Edwards, issued September 11, 2001, however, modified so as to show a desk assembly 10 in accordance

with a third embodiment of the present invention. As seen in Figure 10, a workspace management system 68 is disclosed which comprises a first straight wall 72 and a second straight wall 74. Wall 74 is fixedly connected at its end to wall 72. The walls may be constructed in many known manners. The walls could be of a permanent construction. Preferably, the walls are constructed from prefabricated modular wall partitions such as those taught in any of U.S. Patent Nos. 4,535,577; 4,685,255; 5,209,035; 5,277,005; 5,394,658 and 5,638,650. The walls are formed from individual partitions indicated as 72a, 72b, 72c, 72d and 74a, 74b, with each partition representing a rigid rectangular frame comprising vertical frame members and horizontal frame members to which covers are secured, preferably, for easy removal to access vertical and horizontal raceways underneath the covers in the interior of each partition.

**[0049]** The individual partitions may have different heights as illustrated. Of course, the walls could be a permanent construction in which case they could have a height which extends fully to the ceiling. For ease of illustration, merely one workstation is shown in Figure 10 in which a desk assembly 10 in accordance with the present invention is oriented in a right-angled configuration with the center desk 12 disposed in the corner formed by partitions 74b and 72b with the wing tables extending therefrom. As seen, the straight rear edge 40 of the left wing desktop 11 is disposed to extend along and parallel to the wall 74. The straight rear edge 40 of the right wing desktop 13 is disposed adjacent and parallel to the wall 72.

**[0050]** Figure 10 illustrates the distal end of the wing desktops 11 and 13 being supported on the partition via brackets indicated as 78 secured to the partitions. Thus, in a known manner, each of the wing desk 11 and 13 may be supported from the walls 72 and 74. Similarly, while not shown, the center desktop 12 may be supported from the walls, however, it is generally preferred that the center desktop be independently supported on a suitable leg assembly.

**[0051]** The walls 72 and 74 bordering on the desk assembly are shown as extending to a height above the height of the desk surfaces as is preferred.

**[0052]** Walls to be used in accordance with the desk assembly 10 of the present invention may comprise vertically disposed planar screen panels such as those illustrated in Figure 10 and preferably in which the planar screen panels are connected at their ends as to other panels permitting the panels to assume relative to each other virtually any angular configuration although preferred angles are angles between  $90^\circ$  and  $180^\circ$ . Various connecting assemblies are well known to connect the ends of different panels such that the panels may be adjusted to have an included angle between the panels of being any angle between  $90^\circ$  and  $180^\circ$ .

**[0053]** The preferred center desktop 22 has been described as having a cord edge 34 which extends over an included angle of about  $70^\circ$  thus with the convex edge 32 extending through an included angle of about  $290^\circ$ . It is preferred that the convex edge 34 extend through an included angle of at least  $210^\circ$ . In the preferred embodiments, when assembled, the straight rear edge 40 of each wing desk is disposed to extend substantially tangential to the convex edge 32 of the center desk 12. Therefore, in order to accommodate, for example, a  $90^\circ$  orientation as illustrated in Figure 2, the width W of a wing desktop will, to some measure, determine the length of the cord edge 34 if in the  $90^\circ$  configuration as illustrated in Figure 2, the front edge 50 of each wing desk is not to extend forwardly beyond the cord edge 34. Preferably, the cord edge 34 has a length of at least 20 inches which is the width of a typical computer keyboard.

**[0054]** The included angle A of the convex edge 32 will be a function of the width W of the wing tables and the radius R of the center tables.

**[0055]** The preferred embodiment shows the cord edge 34 as comprising a straight line. It is to be appreciated that this is not necessary and what is referred to as the cord edge 34 need not be straight but may be slightly concave or slightly convex as illustrated, for example, in dotted lines 82 and 84 in Figure 2 showing a convex orientation 92, a concave orientation 94 and, as well, a convex orientation 96 preferably with the radius of these edges 94 and 96 being of a radius which is substantially greater than the radius R of the circle desktop.

**[0056]** It is preferred that each of the wing tables have the same width  $W$ , however, it is to be appreciated that it is not necessary. It is preferred that the rear edge 40 be straight. The front edge 50 and the distal end edge 48 need not be straight. Alternate configurations for these edges are shown in dotted lines as 96, 97 and 98 in Figure 2. Of course, each of the wing tables may have a different length  $L$ .

**[0057]** While the invention has been described with reference to preferred embodiments, the invention is not so limited. For a definition of the invention, reference is made to the appended claims.

## WE CLAIM:

1. A desk assembly comprising:
  - a center desktop and two extension wing desktops,
  - the center desktop supported on a suitable leg assembly and defining a center desk top surface,
  - the peripheral shape of the center desktop is a segment of a circle bounded by a convex edge comprising an arc of a first constant radius and by a chord edge comprising a chord of the circle,
  - the convex edge having a first end point and a second end point, the arc extending about a center point of the circle centered on the center desktop through an included angle of at least 210 degrees from the first end point to the second point,
  - the chord edge extending from the first end point to the second end point,
  - the two extension wing desktops comprising a right-hand wing desktop and a left-hand wing desktop each having a wing desktop surface,
  - the two extension wing desktops connectable to the center desktop with the wing desktop surfaces forming a continuing surface with the center desktop surface,
  - the peripheral shape of each wing desktop includes a straight rear edge adjacent a concave end edge formed as a concave arc of constant radius equal to the first radius,
  - each concave end edge adapted to mate with the convex edge of the center desktop such that, with the concave end edge of the right-hand wing desktop on the convex edge on the right-hand side of the chord edge and the concave end edge of the left-hand wing desktop wing top on the convex edge on the left-hand side of the chord edge, the right and left-hand wing desktops are attachable to the center desktop in a plurality of different angular positions relative to the center point and therefore relative to each other,
  - the different angular positions including:
    - a straight position in which the rear edge of the right-hand wing desktop and the rear edge of the left-hand wing desktop lie in a straight line, and

a right-angled position in which the rear edge of the right-hand wing desktop and rear edge of the left-hand wing desktop are normal to each other.

2. A desk assembly as claimed in claim 1 wherein the different angular positions include an intermediate angled positions between the straight position and the right-angled position, the intermediate angled positions including a 120 degree position in which the rear edge of the right-hand wing desktop and the rear edge of the left-hand wing desktop are disposed to form an angle of 120 degrees between each other.
- 3 A desk assembly as claimed in claim 1 wherein the straight line is tangential to the convex edge.
4. A desk assembly as claimed in claim 1 wherein the cord edge is a straight line.
5. A desk assembly as claimed in claim 4 wherein the straight line is parallel the cord edge.
6. A desk assembly as claimed in claim 1 wherein the cord edge includes curved edge portions of an arc of greater radius than the first constant radius.
7. A desk assembly as claimed in claim 6 wherein the cord edge includes convex curved edge portions.
8. A desk assembly as claimed in claim 6 wherein the cord edge includes concave curved edge portions.
9. A desk assembly as claimed in claim 1 wherein the peripheral shape of each wing desktop is elongate, extending away from the concave end edge to a distal end edge opposite to the concave end edge,

the peripheral shape of each wing desktop including a front edge opposite to the rear edge,

each of the concave end edge and the distal end edge spanning between the front edge and the rear edge.

10. A desk assembly as claimed in claim 1 wherein one of the right-hand wing desktop and the left-hand wing desktop each comprises a portion thereof including the concave end edge and portions of the rear edge and the front edge which is a mirror image of the other of the right-hand wing desktop and the left-hand wing desktop.

11. A desk assembly as claimed in claim 1 wherein the right-hand wing desktop and the left-hand wing desktop each comprising a mirror image of the other.

12. A desk assembly as claimed in claim 1 wherein the peripheral shape of each wing desktop includes a straight front edge parallel the rear edge.

13. A desk assembly as claimed in claim 9 wherein the front edge is parallel the rear edge and the distal end edge normal to the rear edge.

14. A desk assembly as claimed in claim 1 wherein each of the right-hand wing desktop and the left-hand wing desktop center desktop is supported on a suitable, respective leg assembly independently of the center desktop.

15. A desk assembly as claimed in claim 1 wherein each of the right-hand wing desktop and the left-hand wing desktop are supported at their concave end edge by the center desktop and proximate the respective distal by a respective, suitable leg assembly independent of the center desktop.

16. A desk assembly as claimed in claim 1 wherein the continuing surface formed by said center desktop surface and the two extension wing desktops is symmetrical about a line of symmetry passing through the center point.

17. A desk assembly as claimed in claim 1 in combination with a plurality of vertically disposed, planar screen panels which extend to a height above the table surface, the panels including a right-hand panel and a left-hand panel joined at one end forming an included angle between the first panel and the second panel of between 90 and 180 degrees,

the desk assembly located in the included angle between the first and second panels with the right-hand panel located adjacent the rear edge of the right-hand wing desk top extending parallel thereto, and the left-hand panel located adjacent the rear edge of the left-hand wing desktop extending parallel thereto.

18. A plurality of desk assemblies as claimed in claim 1 in combination with a plurality of vertically disposed, planar screen panels which extend to a height above the table surface,

each panel having a first end and a second end, and a first planar side and a second planar side,

the panels including a first panel, a second panel and a third panel,

the second end of the first panel joined to the first end of the second panel ends forming an angle between the first panel and the second panel of between 90 and 180 degrees and the second end of the second panel joined to the first end of the third panel and forming an angle between the second panel and the third panel of between 90 and 180 degrees,

a first of the desk assemblies disposed between the first panel and the second panel with the first planar side of first panel located adjacent the rear edge of the right-hand wing desktop of the first desk assembly extending parallel thereto and the first

planar side of the second panel located adjacent the rear edge of the left-hand wing desktop of the first desk assembly extending parallel thereto,

a second of the desk assemblies disposed between the second panel and the third panel with the second planar side of second panel located adjacent the rear edge of the right-hand wing desktop of the second desk assembly extending parallel thereto and the second planar side of the third panel located adjacent the rear edge of the left-hand wing desktop of the second desk assembly extending parallel thereto.

19. A plurality of desk assemblies as claimed in claim 1 in combination with a plurality of vertically disposed, planar screen panels which extend to a height above the table surface,

each panel having a first end and a second end, and a first planar side and a second planar side,

the panels including a first panel, a second panel and a third panel,

the first end of each of the first, second and third panels joined together such that the panels extend radially from the hub to their second ends forming an angle between the first panel and the second panel of between 90 and 180 degrees and forming an angle between the second panel and the third panel of between 90 and 180 degrees,

a first of the desk assemblies disposed between the first panel and the second panel first with the first planar side of first panel located adjacent the rear edge of the right-hand wing desktop of the first desk assembly extending parallel thereto and the second planar side of the second panel located adjacent the rear edge of the left-hand wing desktop of the first desk assembly extending parallel thereto,

a second of the desk assemblies disposed between the second panel and the third panel with the first planar side of second panel located adjacent the rear edge of the right-hand wing desktop of the second desk assembly extending parallel thereto and the second planar side of the third panel located adjacent the rear edge of the left-hand wing desktop of the second desk assembly extending parallel thereto.

20. A plurality of desk assemblies as claimed in claim 1 in combination with a plurality of vertically disposed, planar screen panels which extend to a height above the table surface,

each panel having a first end and a second end, and a first planar side and a second planar side,

the panels including a first panel, a second panel and a third panel,

the first end of each of the first, second and third panels joined together such that the panels extend radially from the hub to their second ends forming an angle between the first panel and the second panel of between 90 and 180 degrees, forming an angle between the second panel and the third panel of between 90 and 180 degrees and forming an angle between the third panel and the first panel of between 90 and 180 degrees,

a first of the desk assemblies disposed between the first panel and the second panel with the first planar side of first panel located adjacent the rear edge of the right-hand wing desktop of the first desk assembly extending parallel thereto and the second planar side of the second panel located adjacent the rear edge of the left-hand wing desktop of the first desk assembly extending parallel thereto,

a second of the desk assemblies disposed between the second panel and the third panel with the first planar side of second panel located adjacent the rear edge of the right-hand wing desktop of the second desk assembly extending parallel thereto and the second planar side of the third panel located adjacent the rear edge of the left-hand wing desktop of the second desk assembly extending parallel thereto,

a third of the desk assemblies disposed between the third panel and the first panel with the first planar side of third panel located adjacent the rear edge of the right-hand wing desktop of the third desk assembly extending parallel thereto and the second planar side of the first panel located adjacent the rear edge of the left-hand wing desktop of the third desk assembly extending parallel thereto.

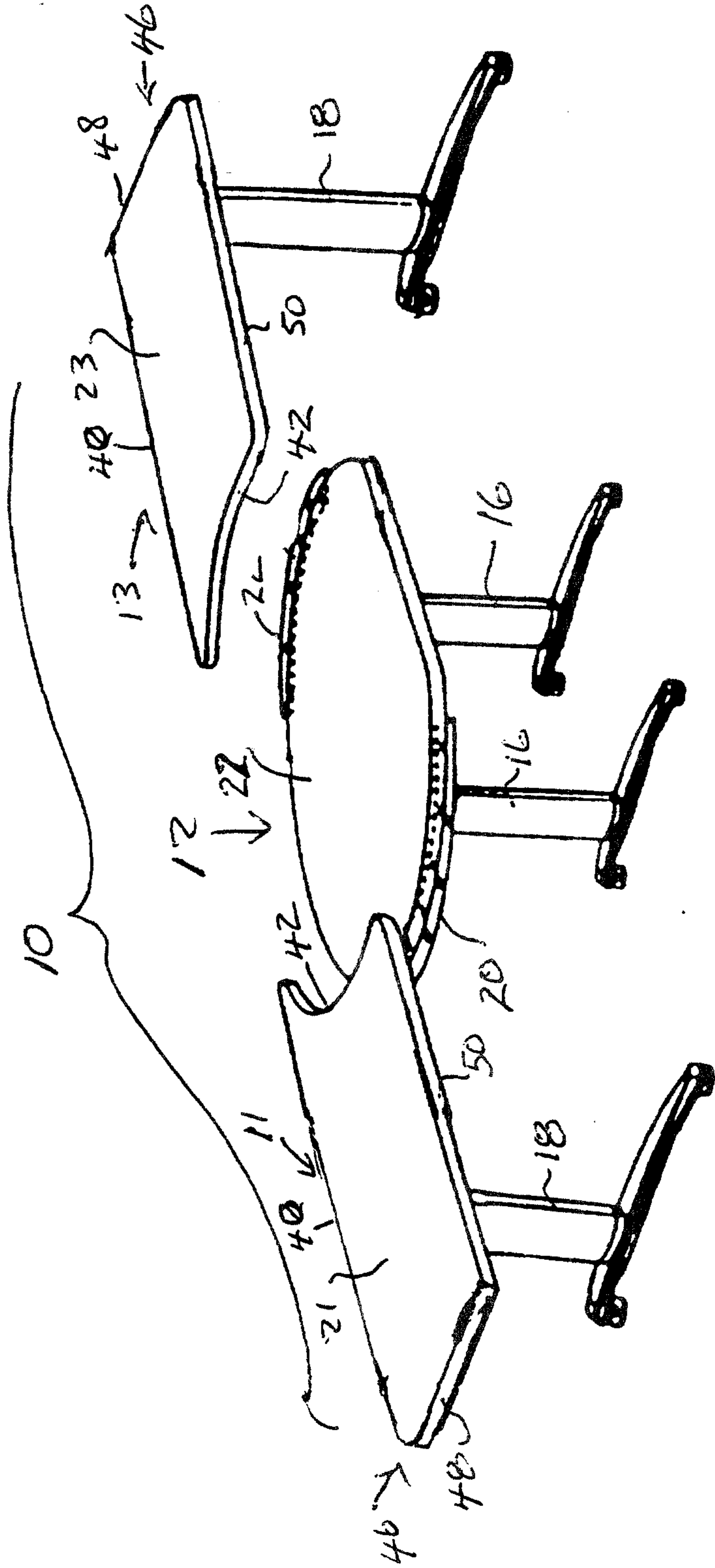

FIG 1

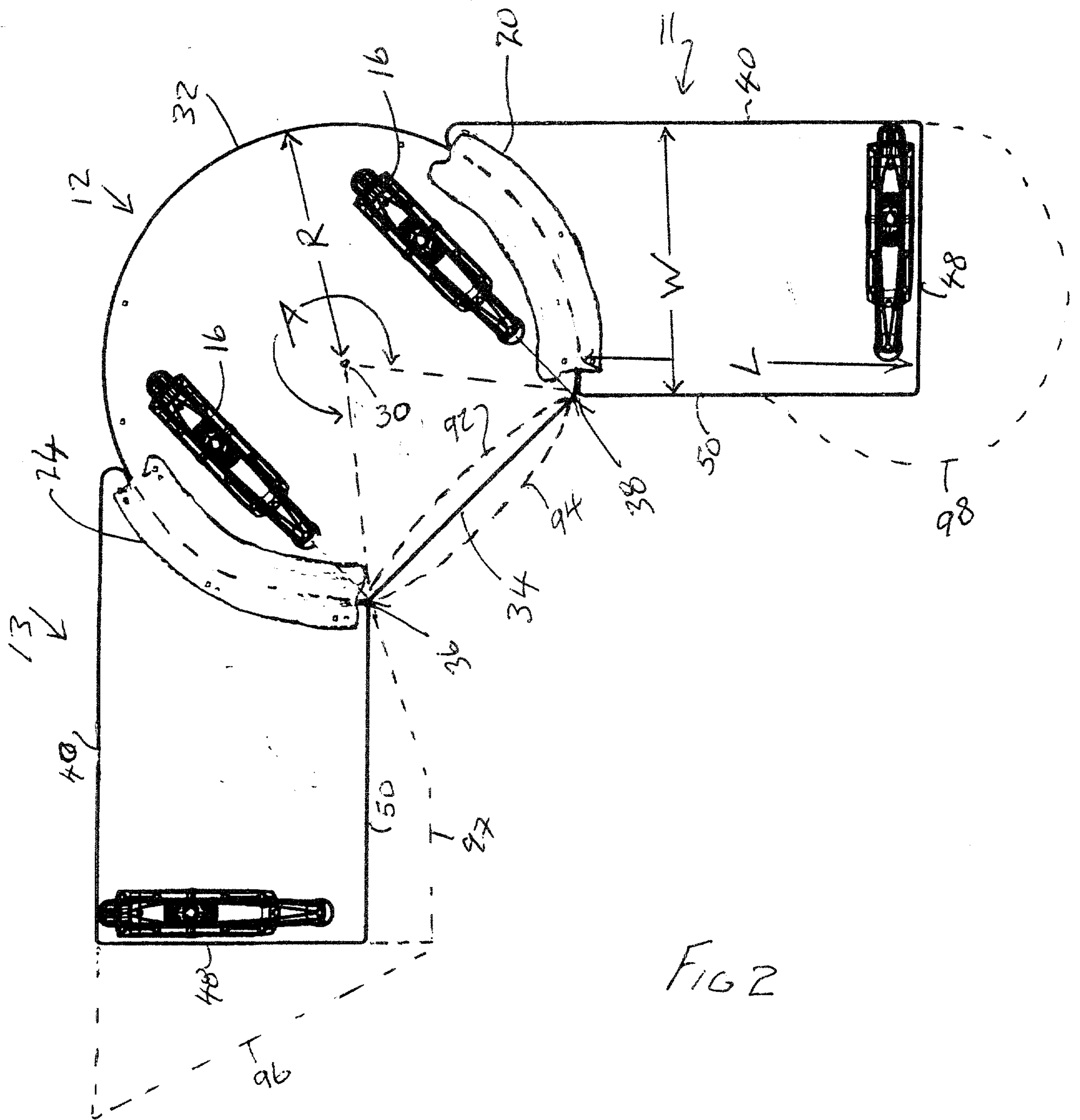

FIG 2

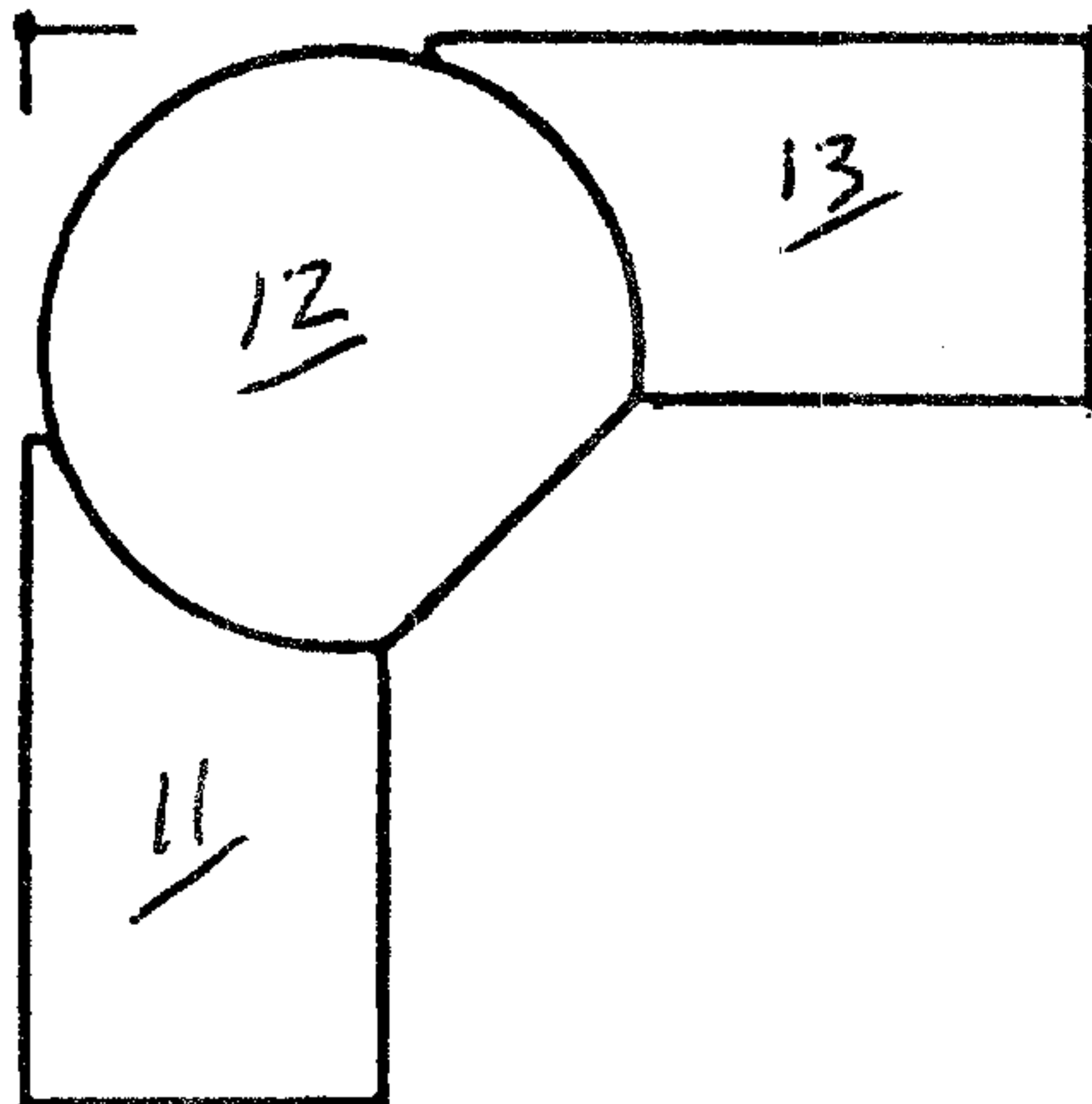

FIG 3

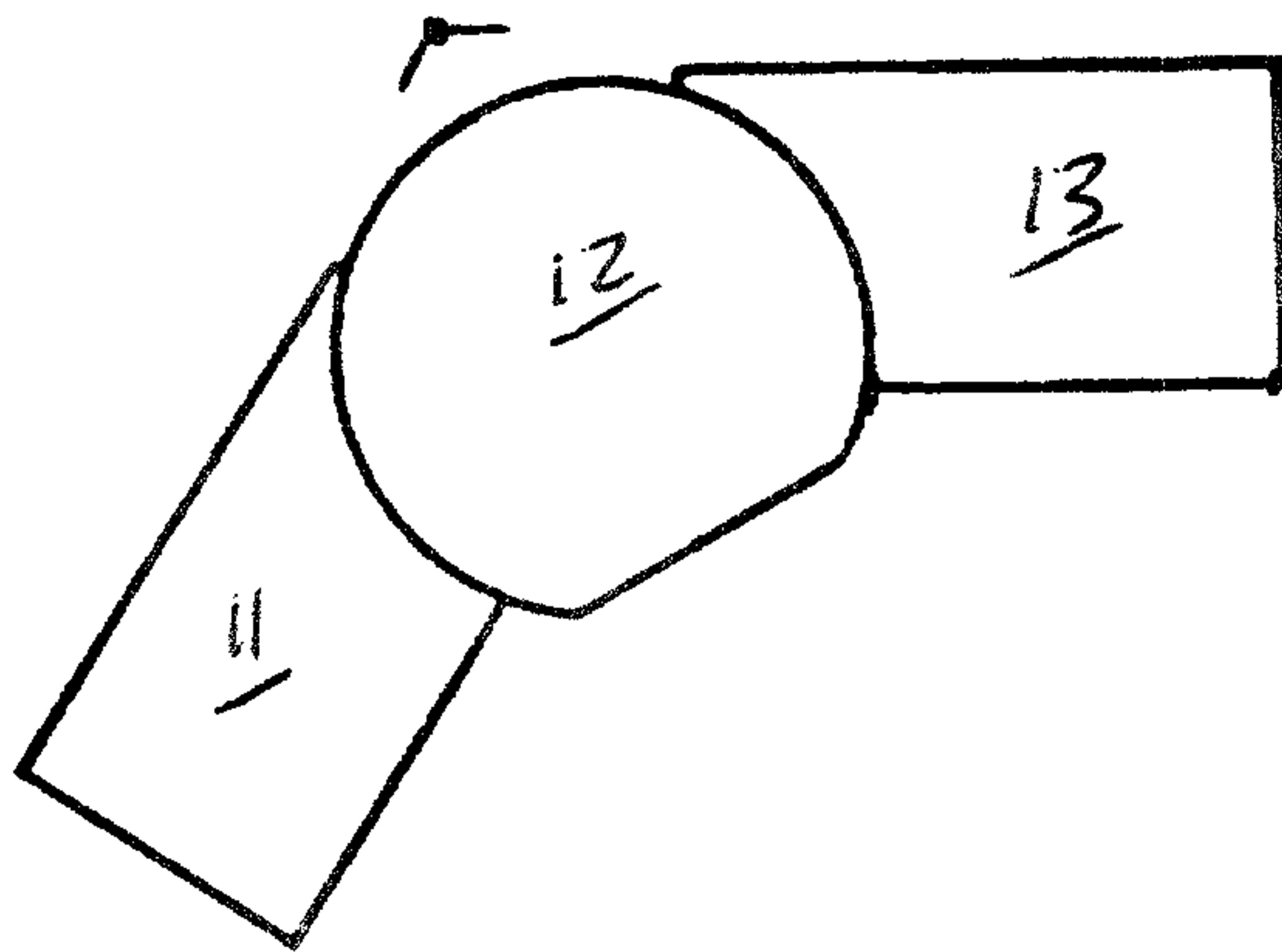

FIG 4

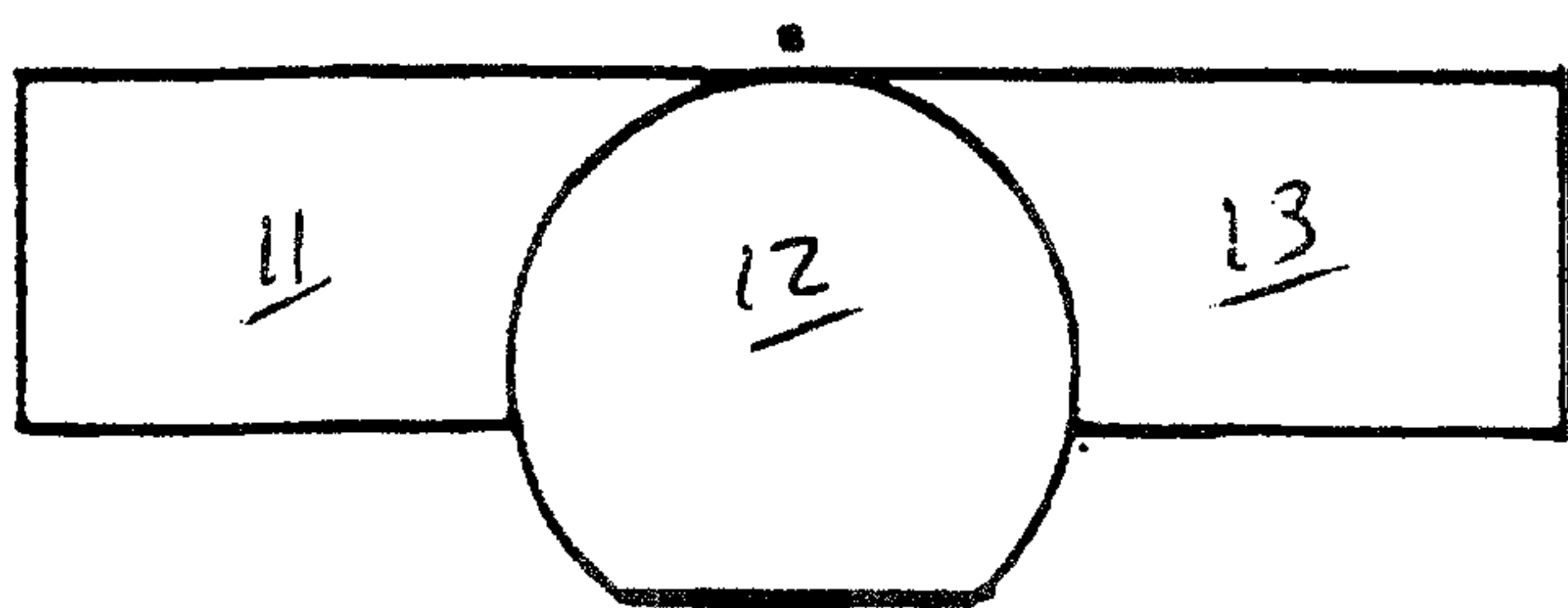

FIG 5

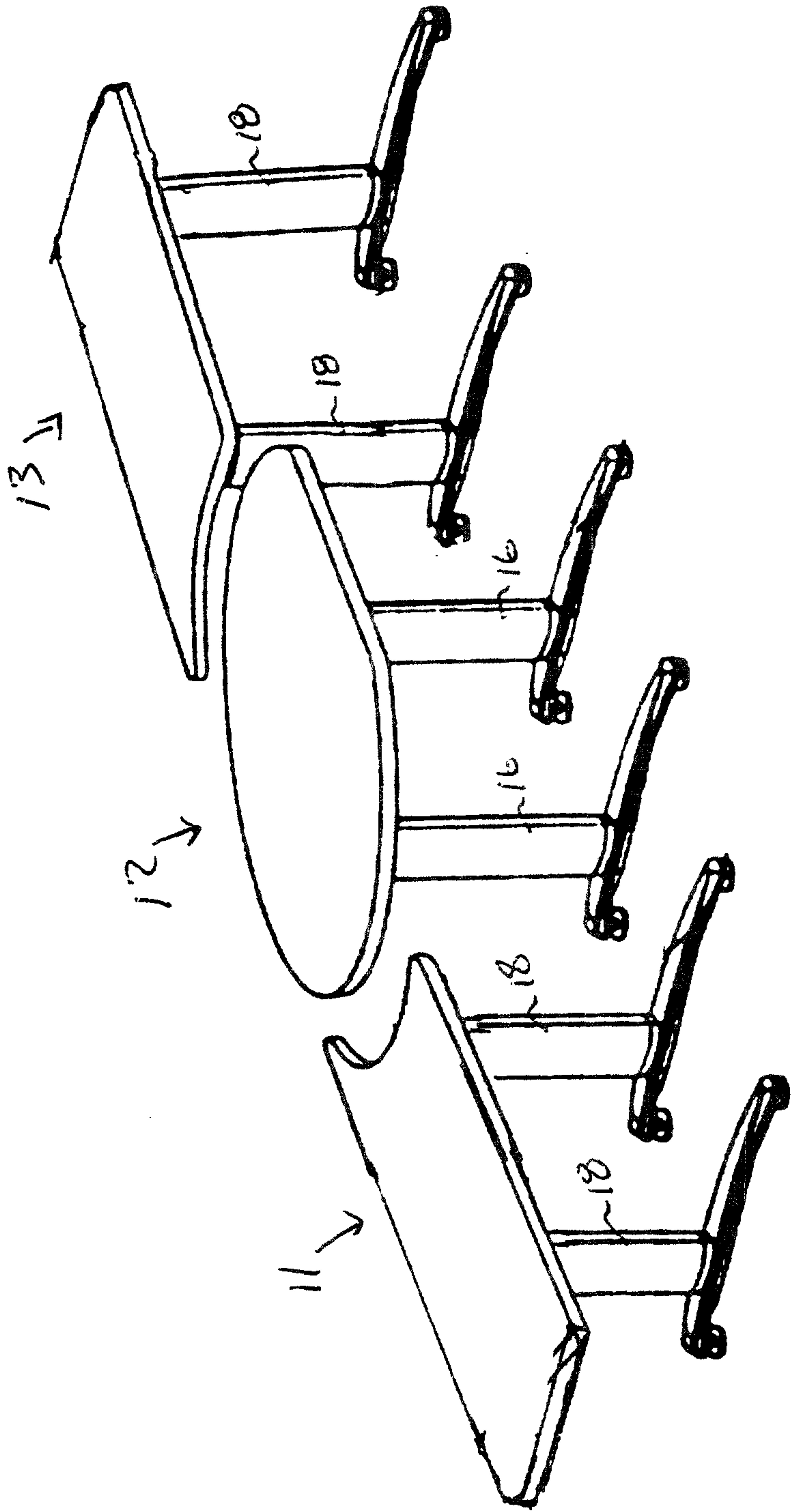
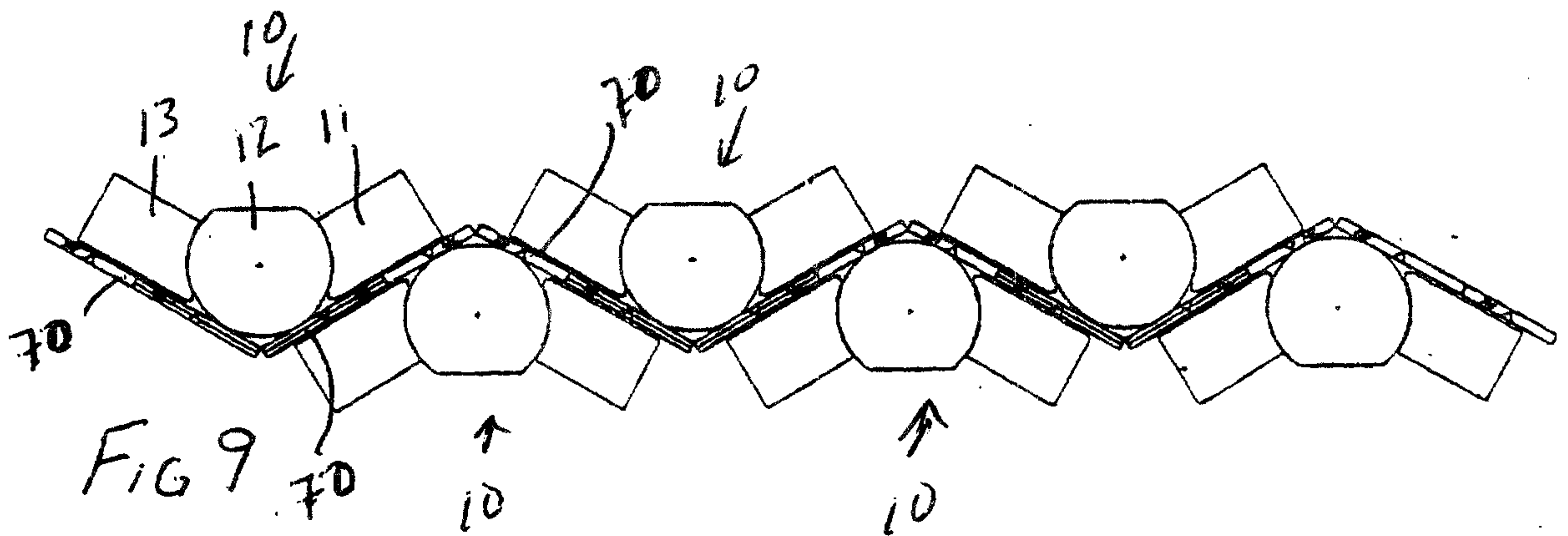
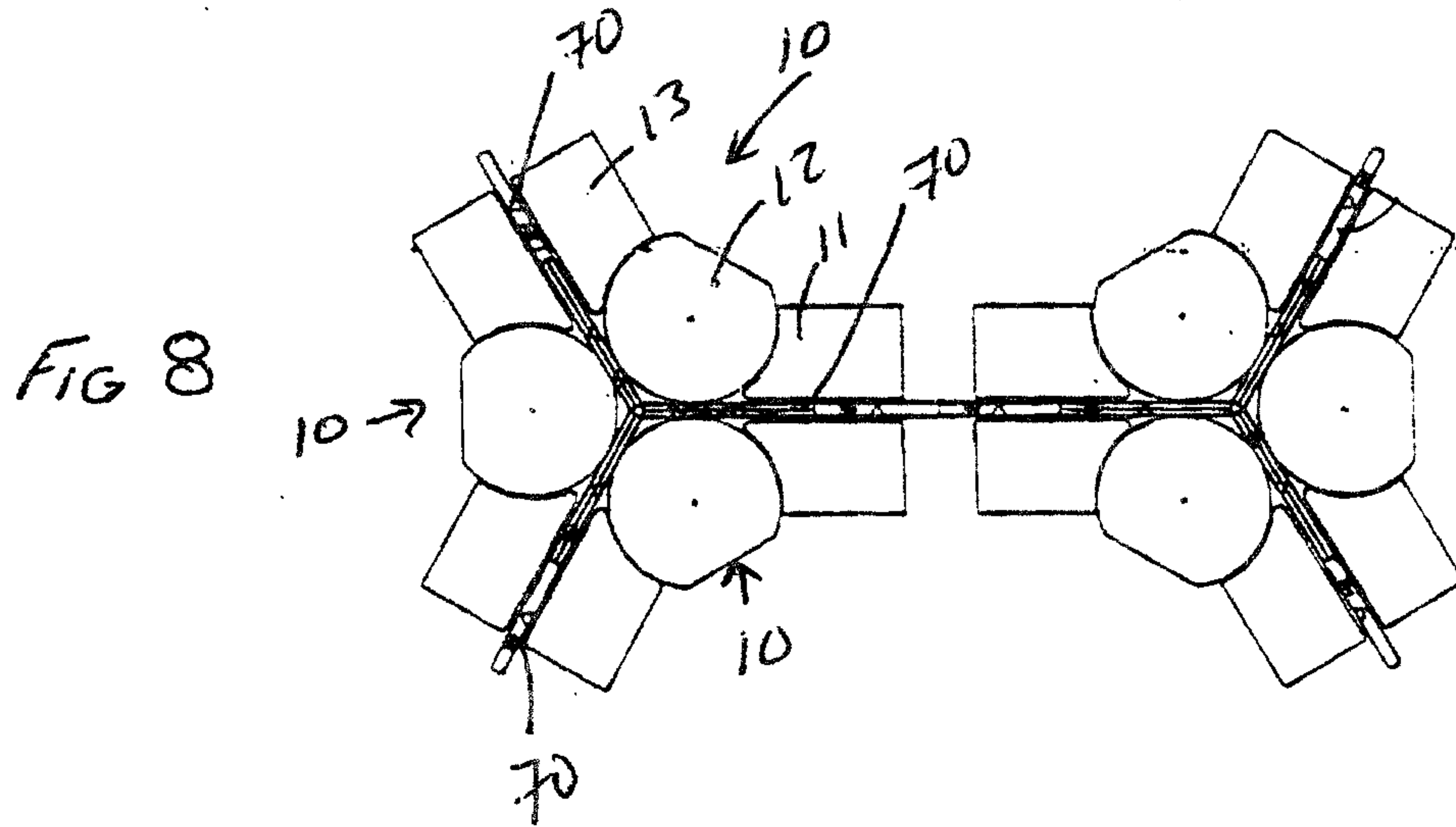
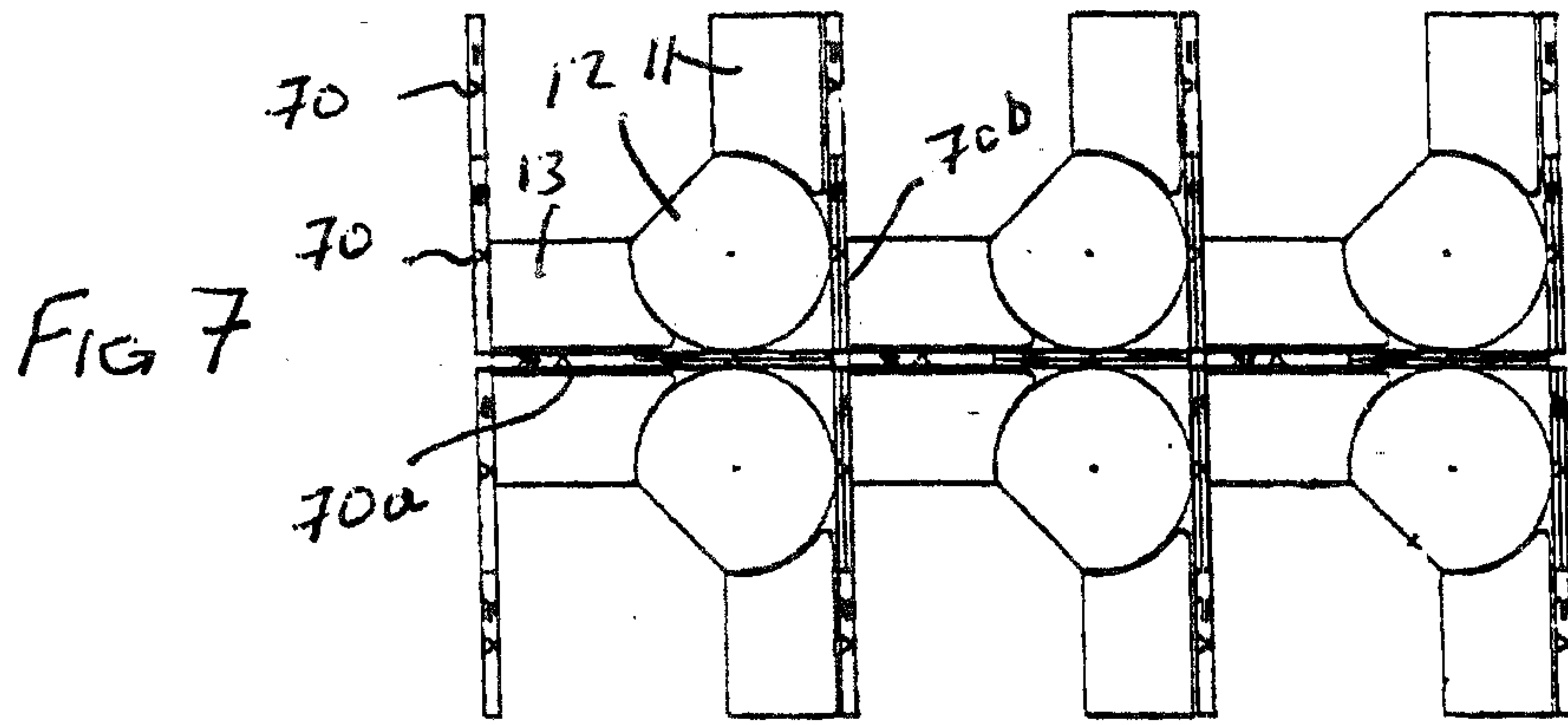

FIG 6



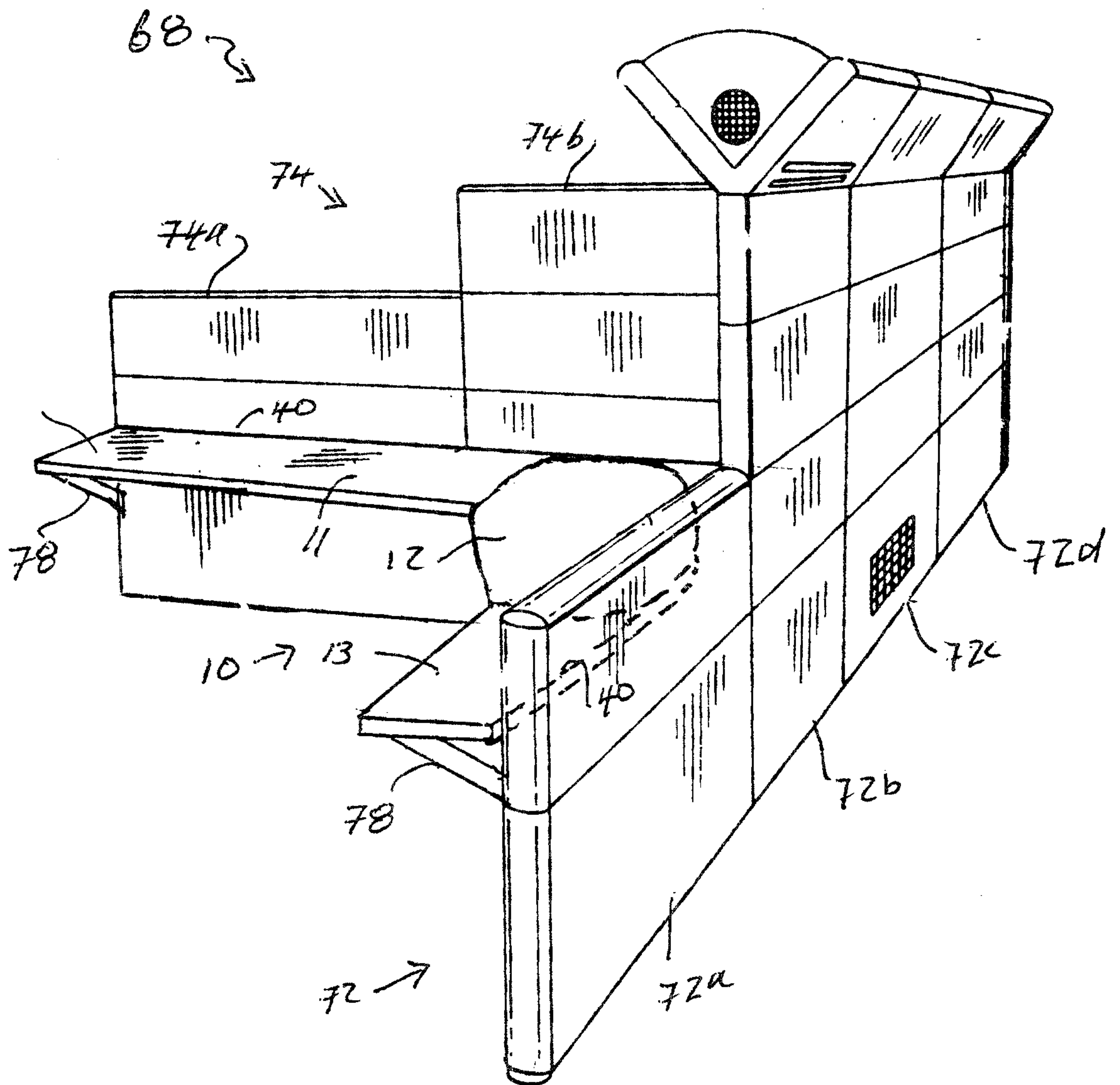

FIG 10

