



(12) **EUROPEAN PATENT APPLICATION**

(88) Date of publication A3:
22.10.1997 Bulletin 1997/43

(51) Int Cl.⁶: **F24F 11/00, B63J 2/04,
F24F 13/12**

(43) Date of publication A2:
06.03.1996 Bulletin 1996/10

(21) Application number: **95850148.8**

(22) Date of filing: **29.08.1995**

(84) Designated Contracting States:
DE DK FR GB IT NL

- Ahlfors, Thomas
S-448 31 Floda (SE)
- Bergström, Gary
S-439 00 Onsala (SE)

(30) Priority: **05.09.1994 SE 9402964**

(71) Applicant: **ABB FLÄKT AB
S-120 86 Stockholm (SE)**

(74) Representative: **Roth, Ernst Adolf Michael et al
GÖTEBORGS PATENTBYRA AB
Box 5005
402 21 Göteborg (SE)**

(72) Inventors:
• Götmalm, Örjan
S-430 41 Kullavik (SE)

(54) **Ventilating apparatus**

(57) A ventilation apparatus for ventilation and temperature control in accommodations, e.g. in vessels, comprising an inlet which is connected to a ventilation channel and at least one outlet which is connected to said accommodation. Damper means (17) are located between the inlet and the outlet, for volume control of the air flow to the accommodation via at least two cooperating damper discs (19, 21). The discs are provided with flow passages (30, 32) the flow area of which are variable by rotating at least one of the damper discs (21) around a spindle (20). The damper means (17), heat production means (15) and sensors (27, 28) connected

to the control unit (16), are located in a cylindrical channel section (10). Each flow passage (30, 32) in the damper means, form in every position of rotation a funnel which narrows gradually in the direction of flow, so that the damper means (17) in almost completely closed position presents slit-shaped flow openings with wall which converge in the direction of flow. One of the damper discs (19) is thin and located upstream another damper disc (21), and is also provided with a number of vanes (31) corresponding to the number of flow passages (32), which vanes project into the flow passages, to form one side in the flow passage with substantially the same length as the other sides.

FIG. 1

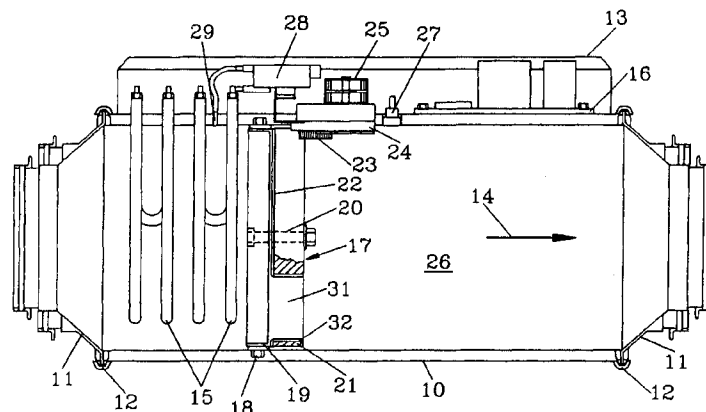



European Patent
Office

EUROPEAN SEARCH REPORT

Application Number
EP 95 85 0148

DOCUMENTS CONSIDERED TO BE RELEVANT			
Category	Citation of document with indication, where appropriate, of relevant passages	Relevant to claim	CLASSIFICATION OF THE APPLICATION (Int.Cl.6)
A	US 4 553 696 A (ICHIKAWA) 19 November 1985 * column 2, line 55 - column 6, line 54; figures 1-9 *	1	F24F11/00 B63J2/04 F24F13/12
A	EP 0 136 957 A (TAGNON) 10 April 1985 * page 5-7; figures 1-4 *	1	
A	FR 2 180 798 A (LTG LUFTECHNISCHE GMBH.) 30 November 1973 * page 5, line 17 - page 9, line 31; figures 1-8 *	1	
A	US 4 426 918 A (LAMBERT) 24 January 1984 * column 4, line 18 - line 25; figures 1-6 *	1	
A	CH 325 775 A (ATELIERS LYONNAIS D'EMBOUTISSAGE SPECIAL FEUGA & LACROIX) 15 January 1958 * page 1-2; figures 1-6 *	4	
A	US 3 528 359 A (SAND) 15 September 1970 * figures 5,6 *	1	TECHNICAL FIELDS SEARCHED (Int.Cl.6) F24F
The present search report has been drawn up for all claims			
Place of search THE HAGUE		Date of completion of the search 22 August 1997	Examiner Vollering, J
CATEGORY OF CITED DOCUMENTS		T : theory or principle underlying the invention E : earlier patent document, but published on, or after the filing date D : document cited in the application L : document cited for other reasons & : member of the same patent family, corresponding document	
X : particularly relevant if taken alone Y : particularly relevant if combined with another document of the same category A : technological background O : non-written disclosure P : intermediate document			

EPO FORM 1500 (01.82) (P/04/01)