

(19) World Intellectual Property Organization
International Bureau



(43) International Publication Date
12 February 2009 (12.02.2009)

PCT

(10) International Publication Number
WO 2009/019562 A2

(51) International Patent Classification⁰: Not classified

(21) International Application Number:
PCT/IB2008/002017

(22) International Filing Date: 23 July 2008 (23.07.2008)

(25) Filing Language: Italian

(26) Publication Language: English

(30) Priority Data:
BO2007A000576 7 August 2007 (07.08.2007) IT

(71) Applicant (for all designated States except US): SPAL
AUTOMOTIVE S.R.L. [IT/IT]; Via per Carpi, 26/B,
I-42015 Correggio (IT).

(72) Inventor; and

(75) Inventor/Applicant (for US only): DE FILIPPIS, Pietro
[IT/IT]; Via Cesare Battisti, 20, I-17019 Varazze (IT).

(74) Agents: BIANCIARDI, Ezio et al.; Bugnion S.p.A., Via
Goito, 18, I-40126 Bologna (IT).

(81) Designated States (unless otherwise indicated, for every kind of national protection available): AE, AG, AL, AM, AO, AT, AU, AZ, BA, BB, BG, BH, BR, BW, BY, BZ, CA, CH, CN, CO, CR, CU, CZ, DE, DK, DM, DO, DZ, EC, EE, EG, ES, FI, GB, GD, GE, GH, GM, GT, HN, HR, HU, ID, IL, IN, IS, JP, KE, KG, KM, KN, KP, KR, KZ, LA, LC, LK, LR, LS, LT, LU, LY, MA, MD, ME, MG, MK, MN, MW, MX, MY, MZ, NA, NG, NI, NO, NZ, OM, PG, PH, PL, PT, RO, RS, RU, SC, SD, SE, SG, SK, SL, SM, ST, SV, SY, TJ, TM, TN, TR, TT, TZ, UA, UG, US, UZ, VC, VN, ZA, ZM, ZW.

(84) Designated States (unless otherwise indicated, for every kind of regional protection available): ARIPO (BW, GH, GM, KE, LS, MW, MZ, NA, SD, SL, SZ, TZ, UG, ZM, ZW), Eurasian (AM, AZ, BY, KG, KZ, MD, RU, TJ, TM), European (AT, BE, BG, CH, CY, CZ, DE, DK, EE, ES, FI, FR, GB, GR, HR, HU, IE, IS, IT, LT, LU, LV, MC, MT, NL, NO, PL, PT, RO, SE, SI, SK, TR), OAPI (BF, BJ, CF, CG, CI, CM, GA, GN, GQ, GW, ML, MR, NE, SN, TD, TG).

Published:
— without international search report and to be republished upon receipt of that report

(54) Title: ELECTRIC MACHINE

FIG 2

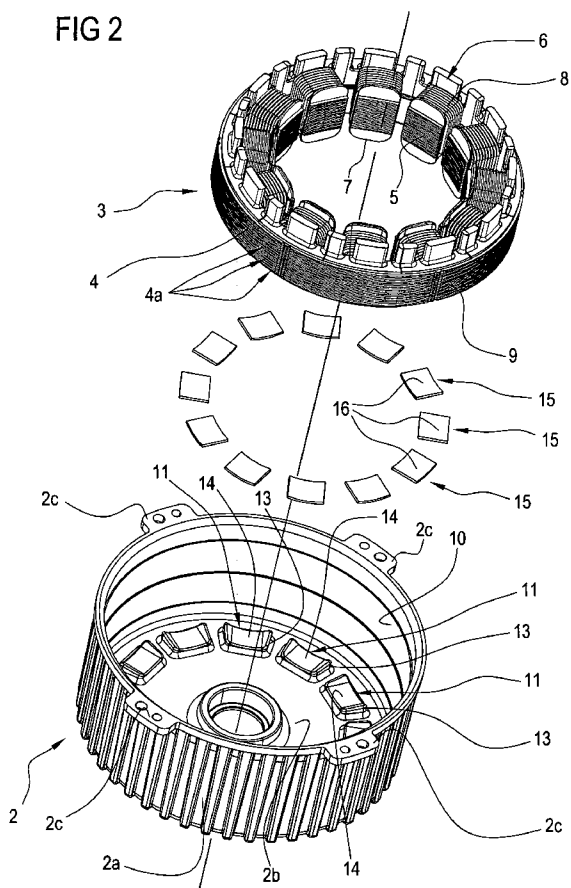

(57) Abstract: An electric machine comprises an outer casing (2), a rotor and a stator (3) having at least one polar expansion (5) and at least one winding (8) having an annular shape and placed around the polar expansion (5). The casing (2) has a plurality of protrusions (13) each of which holds, by supporting, a corresponding portion (12) of a stator winding (8) to enable heat exchange between the winding (8) and the protrusion (13). Each portion (12) of the winding (8) is electrically insulated from the respective protrusion (13).

WO 2009/019562 A2

Description

Electric machine

Technical Field

This invention relates to an electric machine.

5 In particular, the invention relates to a rotary electric machine of the type with stator windings, for example a motor of the type used to drive an electric cooling fan for automotive applications or an electricity generator. Preferably, the electric machine according to this invention is a brushless type electric motor.

10 The invention also refers to a sealed electric machine, particularly suitable for use in dusty environments or in environments characterized by an atmosphere unsuitable for entering into direct contact with the electromechanical components of the electric machine.

Background Art

15 Prior art windings for an electric machine, whether they are of the stator or rotor type, are made from a plurality of turns of a conductive material, generally copper, formed by winding a lead wire around two or more polar expansions of the stator and/or the rotor of the electric machine. The winding, through which an electric current passes, must be suitably insulated from the polar expansions, which are made from ferromagnetic material. For this purpose, prior art places a layer of electrically insulating material between the winding and the corresponding polar expansion on which it is wound.

Electric currents, including high ones, pass through the winding and cause heating due to the Joule effect which extends through the entire winding and adjacent areas of the electric machine.

25 In particular, it has been found that the heat produced in this way deteriorates the conductivity properties of the lead wire, which consequently generates a greater resistance to the passage of current causing a high and often unacceptable energy loss.

30 In addition, the overheating of the winding may result in fast deterioration of the insulation characteristics of the above-mentioned layer of electrically insulating material placed between the winding and the corresponding polar expansion on which it is wound. This results in evident risks of short circuits and permanent damage to the electric machine, which must therefore be replaced or undergo costly

maintenance.

This situation is particularly serious in rotary electric machines of the sealed type, in which the windings are immersed in a sealed environment subjected to continuous heating due essentially to the above-mentioned heating caused by the Joule effect. This sealed environment is not subject to an exchange of air, and, under steady-state conditions, there may be high temperatures inside this environment which favour overheating of the windings.

Disclosure of the Invention

The aim of the present invention is therefore to provide an electric machine that is free of the above-mentioned shortcomings.

One aim of the present invention is to provide an electric machine with a high level of reliability.

Another aim of the invention is to provide an electric machine which makes best use of the available power, minimising the energy losses.

The stated technical purposes and aims, and others, are substantially achieved by an electric machine as described in claim 1 and in one or more of the claims dependent thereon.

Brief Description of the Drawings

Further features and advantages of the present invention are more apparent in the detailed description below, with reference to a preferred, non-limiting, embodiment of an electric machine, as illustrated in the accompanying drawings, in which:

- Figure 1 illustrates a perspective view of a detail of an electric machine according to the present invention, with some parts cut away to better illustrate others;

- Figure 2 illustrates a perspective exploded view of the detail of Figure 1;

- Figure 3a illustrates a plan view of the detail of Figure 1;

- Figure 3b illustrates a plan view of a first portion of the detail of Figure 1;

- Figure 4 illustrates a perspective exploded view of a second portion of the detail of Figure 1;

- Figure 5 illustrates a section view of the detail of Figure 1 through the line V-V shown in Figure 3a;

- Figure 6 illustrates a section view of the detail of Figure 1 through the line

VI-VI shown in Figure 5.

Detailed Description of the Preferred Embodiments of the Invention

The electric machine described in detail below is specifically an electric motor.
5 However, the technical characteristics and the teachings of the present invention also apply to other rotary electric machines, in particular to electricity generators.

With reference to the accompanying drawings, the numeral 1 denotes in its entirety an electric motor according to the present invention.

10 The electric motor 1 comprises a casing 2 to define an outer shell, a stator 3 permanently associated inside the casing 2, and a rotor which is not illustrated since it is not relevant to the present invention.

Preferably, the electric motor 1 in accordance with the present invention is of the sealed type. For this purpose, the casing 2 comprises a substantially cylindrical lateral wall 2a and a bottom wall 2b rigidly connected to the lateral wall 2a to define a single body with a bell shape. On the opposite side to the bottom wall 2b, the lateral wall 2a has a substantially circular opening "A" and it is permanently associated with a closing cap or cover, which is not illustrated, in particular by means of flanges 2c jutting out from the lateral wall 2a. The bottom wall 2b is also fitted with a central hole "F" used to house a bearing

20 The stator 3 is of the wound type, and comprises a stator body 4 with a toroidal shape and defined by a plurality of superposed laminations 4a packed together to define a single body, as illustrated in Figure 4. The stator body 4 has at least one polar expansion 5, preferably a plurality spaced at equal angular intervals. Each polar expansion 5 extends radially towards an axis "X" of the stator 3 around which the stator 3 extends to coincide substantially with an axis of rotation of the rotor.

As shown in Figure 4, the stator 3 also comprises a pair of half shells 6, 7 made from insulating material and which may be associated together to substantially envelop all the above-mentioned polar expansions 5. In particular, the two insulating half shells 6, 7 define electrical insulating elements between the winding 8 and the polar expansion 5 and they approach each other from opposite sides of the stator body 4 along a direction parallel to the above-mentioned axis "X" of the stator 3. More in detail, each half shell 6, 7 has an annular portion 6a, 7a and a plurality of protruding portions 6b, 7b each to be used to at least partially envelop a respective polar expansion 5.

35 Each polar expansion 5, covered with the respective pair of protruding portions

6b, 7b, defines a core on which a respective stator winding 8 may be formed. As shown in Figure 2, each winding 8 has an annular form and comprises a plurality of adjacent and/or superposed turns connected in series, obtained by winding a single lead wire around the above-mentioned core. The presence of the protruding portions 5
5 6b, 7b of the insulating half shells forms an electrical insulation of the winding 8 with respect to the corresponding polar expansion 5. Figure 2 illustrates the stator 3 after the windings 8 have been formed.

The stator 3 is inserted in the casing 2, in particular by means of a customary keying or shrinking-on process, in which a cylindrical lateral surface 9 of the stator
10 body 4 is coupled with a corresponding cylindrical inner surface 10 of the casing 2, in order to reach a configuration illustrated in Figures 1 and 5. The stator 3 is inserted in the casing 2 along the above-mentioned axis "X" of the stator 3.

Figure 3 illustrates in detail the angular distribution of the twelve polar
15 expansions 5 placed at angular intervals from each other, preferably equally spaced.

Advantageously, the bottom wall 2b of the casing 2 has at least one butting
20 portion 11 to engage, preferably by supporting, with a portion 12 of the winding 8 to enable heat exchange from the portion 12 of the winding 8 to the butting portion 11 in order to cool the winding 8. In order to improve this cooling effect, and in accordance with an embodiment not illustrated, the bottom wall 2b of the casing 2
25 has an outer surface, that is to say, facing the outside of the electric motor 1, fitted with fins to favour heat exchange between the bottom wall 2b and the outside environment.

Preferably, the butting portion 11 is substantially shaped to match an outer
30 shape of the portion 12 of the winding 8 which it holds, and it is defined by a protrusion 13 formed on the bottom wall 2b of the casing 2. The protrusion 13 extends away from the bottom wall 2b to a space inside the electric motor 1, and it faces a direction preferably parallel to the axis "X" of the stator 3. The portion 12 of the winding 8 which engages with the protrusion 13 is, in particular, a front portion of the winding 8 facing the bottom wall 2b of the casing 2, along a direction for
35 inserting the stator 3 in the casing 2.

The protrusion 13 has a rounded butting surface 14 whose concavity faces the
opposite side with respect to the bottom wall 2b, that is to say, faces the above-mentioned space inside the electric motor 1. The butting surface 14 may therefore be engaged with the portion 12 of the winding 8, the portion 12 of which is part of the
35 toroidal form of the winding 8 and is therefore curved and, more in detail, convex.

As shown in Figure 3b, the bottom wall 2b has a plurality of protrusions 13, in particular twelve protrusions 13 spaced at equal angular intervals and placed around the axis "X" of the stator 3. The protrusions 13 are located on the bottom wall 2b at the positions adopted by the respective portions 12 of the windings 8 after assembly of the electric motor 1, that is to say, after the stator 3 has been fitted in the casing 2.

Advantageously, between each protrusion 13 and the respective portion 12 of the winding 8 there is at least one intermediate element 15, either rigid or flexible, made from a thermally conductive and electrically insulating material. Preferably, the intermediate element 15 is in the form of a shim 16 and is removably fitted between the protrusion 13 and the portion 12 of the winding 8 to enable transfer of thermal power between the protrusion 13 and the portion 12 of the winding 8 whilst maintaining them electrically insulated, in order to avoid short circuits.

Preferably, the intermediate element is a shim made of Silpad ®, and has at least the property of mechanical compressive strength.

In its undeformed state, the shim 16 extends mainly in one plane over an area with a size, measured along this plane, at least equal to a potential surface of contact between the protrusion 13 and the portion 12 of the winding 8, so as to insulate the entire butting surface 14 of the protrusion 13 with respect to the winding 8.

Advantageously, the electric motor 1 comprises thrust means 17 active on the portion 12 of the winding 8 to maintain the above-mentioned portion 12 pressed against the respective protrusion 13. The above-mentioned thrust means 17 are mounted on the stator 3 and comprise at least one elastic element 18 active between the above-mentioned portion 12 of the winding 8 and the stator body 4, in particular the polar expansion 5 of the stator body.

According to a preferred embodiment illustrated in Figures 5 and 6, each elastic element 18 is placed between the stator body 4 and the lower half shell 7 and, in more detail, between a lower surface 21 of the stator body 4 and an upper surface 22 of the respective protruding portion 7b of the lower half shell 7.

Basically, the stator body 4 and the lower half shell 7 delimit a space "S", which is illustrated not in proportion for greater clarity, in which the elastic element 18 is housed.

The space "S" is delimited above by the lower surface 21 of the stator body 4, and below by the upper surface 22 of the respective protruding portion 7b of the lower half shell 7.

The elastic elements 18 are positioned in the space "S" before the windings 8

are formed.

Each portion 12 of the winding 8 engaging with the respective butting portion 11 is movable away from the stator body 4 under the action of the elastic element 18. In addition, the lower half shell 7 keyed to the polar expansion 5 slides on the polar expansion 5 itself.

A stator 3 of the type described above, that is to say, fitted with an elastic element 18 for each winding 8, may be inserted inside the casing 2 along the axis "X" of the stator 3, until it abuts the portions 12 of the windings 8 against the respective protrusions 13 through the above-mentioned interposed shims 16. In particular, the stator 3 is pushed along its axis "X" until the portion 12 of each winding 8 enters into contact with the respective protrusion 13 formed on the bottom wall 2b of the casing 2, and it is further pushed until it compresses each elastic element 18. Following this compression, the stator 3 is permanently fixed, for example on an abutment ledge, not illustrated, preferably in an irreversible manner.

Basically, the stator is inserted, for example hot, inside the casing until it reaches an operational position identified by the abutment ledge at which it is permanently fixed.

In this position the elastic elements 18 apply a predetermined perpetual and substantially constant thrust on the corresponding portion 12 of the winding 8, that is to say, on the lower half shell 7. This results in a significant advantage if shims 16 are used, the electrical insulation and thermal conductivity properties of which reach optimum values if subjected to a substantial surface pressure, for example at least 1.5 kg/cm² in the case of Silpad ® shims

As described above, the stator 3 is fixed to the casing 2 by interference between the lateral cylindrical surface 9 of the stator body 4 and the inner cylindrical surface 10 of the casing 2. If this interference is obtained by shrinking on, in which an expansion of the casing 2 is generated, the thrust action on the stator 3 against the bottom wall 2b of the casing 2 is maintained until the stator 3 has been fixed, that is to say, until a stabilisation of the above-mentioned interference has been reached. In this way, there is no risk of elastic return of the elastic elements 18 during a cooling of the casing 2, which would cause a loss or reduction of the compressive action on the above-mentioned shims 16.

The present invention achieves the above-mentioned aims and overcomes the shortcomings of prior art.

The electric machine according to the present invention provides an effective

cooling action thanks to the adoption of Silpad ® shims which enable heat exchange by conduction between the windings and the casing without this contact generating short circuits in the windings. Consequently, it is possible contain the maximum operating temperatures of the windings, which can therefore be used longer without this causing deterioration of the conductivity properties of the windings, nor decay of the insulating properties of the half shells keyed to the stator body.

5
10
15
Lastly, the presence of the thrust means active on the windings enables the stator to be fitted on the casing maintaining a substantially constant thrust action, with a desired value, of the windings against the protrusions of the casing. This thrust may be in particular determined to achieve optimum operation of the Silpad ® shims. Moreover, the mechanical compressive strength exhibited by the Silpad ® shims enables the shims to be "clamped" between the windings and the protrusions and, at the same time, to make an important contribution to the thermal conductivity and electrical insulation.

Claims

1. An electric machine comprising
- 5 - an outer casing (2);
- a stator (3) having at least one polar expansion (5) and at least one winding (8) having an annular shape and fitted inside the polar expansion (5);
- a rotor;
- 10 characterised in that the casing (2) has at least one butting portion (11) to engage with and support the corresponding portion (12) of the winding (8) to enable heat exchange between the winding (8) and the butting portion (11), the portion (12) of the winding (8) being electrically insulated from the butting portion (11) in a condition of reciprocal engagement between the portions (11, 12).
2. The electric machine according to claim 1, characterised in that it comprises at
- 15 least one thermally conductive and electrically insulating intermediate element (15), the intermediate element (15) having at least the property of mechanical compressive strength and being placed between the portion (12) of the winding (8) and the respective butting portion (11) to facilitate the heat exchange between them whilst keeping them electrically isolated from one other.
- 20 3. The electric machine according to claim 2, characterised in that the intermediate element (15) is removably fitted manner between the portion (12) of the winding (8) and the respective butting portion (11).
4. The electric machine according to claim 2 or 3, characterised in that the intermediate element (15) comprises a shim (16) extending mainly in one plane and
- 25 having dimensions at least equal to a potential surface of contact between the portion (12) of the winding (8) and the respective butting portion (11).
5. The electric machine according to one or more of the foregoing claims, characterised in that the casing (2) comprises a bottom wall (2b) lying substantially perpendicular to an axis of rotation of the rotor, the butting portion (11) being defined
- 30 by a protrusion (13) of the bottom wall (2b) facing a space inside the electric machine (1).
6. The electric machine according to claim 5, characterised in that the protrusion (13) extends away from the bottom wall (2b) along a line parallel to the axis of rotation of the rotor.

7. The electric machine according to claim 5 or 6, characterised in that the protrusion (13) has a butting surface (14) substantially shaped to match the portion (12) of the winding (8).

5 8. The electric machine according to claim 7, characterised in that the butting surface (14) is rounded with concavity facing the space inside the electric machine (1).

9. The electric machine according to claim 4, characterised in that the bottom wall (2b) has a finned outer surface to favour heat exchange between the bottom wall (2b) and the outside of the electric machine (1).

10 10. The electric machine according to one or more of the foregoing claims, characterised in that it comprises thrust means (17) active on the portion (12) of the winding (8) to maintain it pressed against the butting portion (11).

11. The electric machine according to claim 10, characterised in that the thrust means (17) comprise at least one elastic element (18) active between the portion (12) of the winding (8) and the respective polar expansion (5).

12. The electric machine according to claims 10 or 11, characterised in that the winding (8) is wound on the respective polar expansion (5) so as to form a space (S) between the portion (12) of the winding (8) and the respective polar expansion (5), the thrust means (17) being housed inside the space (S).

20 13. The electric machine according to claim 12, characterised in that the space (S) is delimited above by an electrically insulating element (7) active between the polar expansion (5) and the winding (8), and below by the portion (12) of the winding (8).

25 14. The electric machine according to one or more of the foregoing claims, characterised in that it comprises a plurality of butting portions (11) each of which engages with a respective portion (12) of a winding (8).

15. The electric machine according to claim 5, characterised in that the casing (2) has a plurality of protrusions (13) spaced at angular intervals, each of which engages with a respective portion (12) of a winding (8).

30 16. A method for the manufacture of an electric machine, comprising the steps of:
- providing a casing (2) having a lateral wall (2a) and a bottom wall (2b);
- providing a stator (3) having at least one polar expansion (5) and extending around an axis (X) to coincide with an axis of rotation of a corresponding rotor of the electric machine (1);
- forming a winding (8) of a lead wire around the polar expansion (5);

- inserting the stator (3) in the casing (2) along a line parallel to the axis (X) of the stator (3);

characterised in that the step of forming the winding (8) comprises the steps of:

- winding the lead wire around the polar expansion (5) in order to form a space (S) between the portion (12) of the winding (8), to face the bottom wall (2b) of the casing (2), and the polar expansion (5);

- placing an elastic element (18) in the space (S);

- placing, between the portion (12) of the winding (8) and the bottom wall (2b), a thermally conductive and electrically insulating intermediate element (15);

the step of inserting the stator (3) in the casing (2) comprises the step of pressing the stator (3) along its axis (X) to abut the portion (12) of the winding (8) against the bottom wall (2b) generating a compression of the elastic element (18).

17. The method according to claim 16, characterised in that the step of forming the space (S) comprises forming the space (S) between the polar expansion (5) and an electrically insulating element (7) active between the polar expansion (5) and the winding (8).

18. The method according to claims 16 or 17, characterised in that the step of winding the lead wire on the polar expansion (5) comprises winding the conductor loosely on the polar expansion (5) to define the space (S), and subsequently inserting the elastic element (18) in the space (S).

19. The method according to one or more of the claims from 16 to 18, characterised in that the step of winding the lead wire on the polar expansion (5) comprises associating the elastic element (18) with the polar expansion (5) and subsequently winding the lead wire on the polar expansion (5) associated with the elastic element (18) in order to form the space (S) within which the elastic element (18) is housed.

20. The method according to one or more of the claims from 16 to 19, characterised in that the bottom wall (2b) of the casing (2) has at least one protrusion (13), the step of inserting the stator (3) in the casing (2) being performed in such a way as to abut the portion (12) of the winding (8) against the protrusion (13).

21. The method according to one or more of the claims from 16 to 20, characterised in that the step of inserting the stator (3) in the casing (2) comprises a step of permanently fixing the stator (3) to the casing (2), the step of pressing the stator (3) along its axis (X) being maintained until the stator (3) has been fixed.

4/5

FIG 4

