

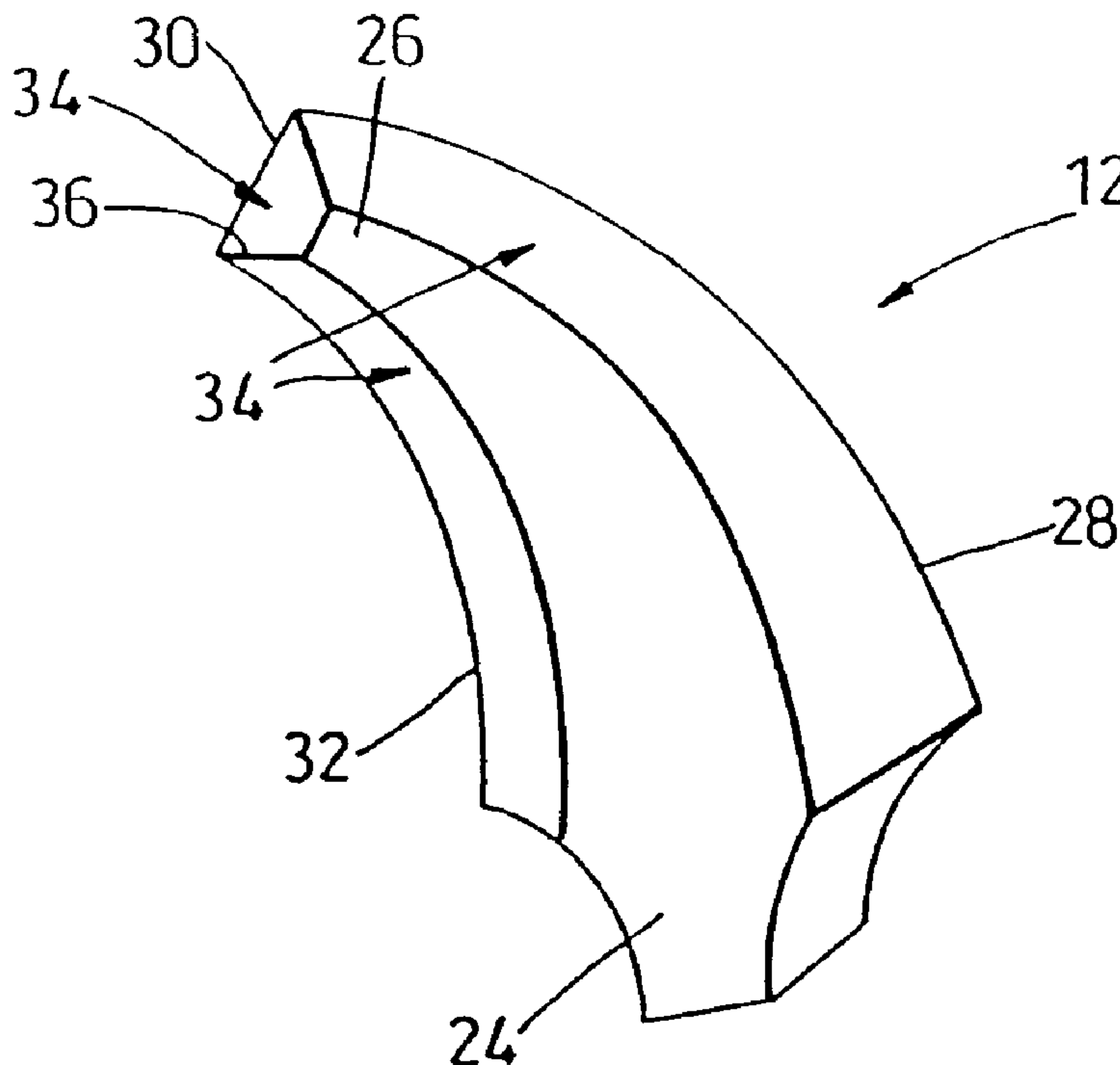

(86) Date de dépôt PCT/PCT Filing Date: 2000/11/02
 (87) Date publication PCT/PCT Publication Date: 2001/05/10
 (45) Date de délivrance/Issue Date: 2005/08/16
 (85) Entrée phase nationale/National Entry: 2002/05/02
 (86) N° demande PCT/PCT Application No.: GB 2000/004203
 (87) N° publication PCT/PCT Publication No.: 2001/033158
 (30) Priorité/Priority: 1999/11/02 (9925851.9) GB

(51) Cl.Int.⁷/Int.Cl.⁷ F41H 11/16
 (72) Inventeur/Inventor:
 FRENCH, JOHN ROBERT, GB
 (73) Propriétaire/Owner:
 J.R. FRENCH LIMITED, GB
 (74) Agent: RUSSELL REYNEKE

(54) Titre : LAME POUR ENSEMBLE D'EXCAVATION ET APPAREILS CORRESPONDANTS
 (54) Title: A BLADE FOR A DIGGING ASSEMBLY, AND RELATED APPARATUSES



(57) Abrégé/Abstract:

A blade (12) for a digging assembly comprises a base portion (24) and a terminal portion (26) remote from the base portion (24). The base portion (24) is wider than the terminal portion (26), and the blade tapers in width between the base and terminal portions (24, 26). First, second and third sharpened edges (28, 30, 32) are provided on the blade (12), each having flanks (34) that subtend an angle of at least 90°. Each of the flanks (34) are skewed in relation to the respective flanks (34) of the other edges. The orientation of the flanks (34) of the sharpened edges (28, 30, 32) enables the blade (12) to exhibit a lifting effect when it is rotated through material on an axis in a digging assembly.

(12) INTERNATIONAL APPLICATION PUBLISHED UNDER THE PATENT COOPERATION TREATY (PCT)

(19) World Intellectual Property Organization
International Bureau



(43) International Publication Date
10 May 2001 (10.05.2001)

PCT

(10) International Publication Number
WO 01/33158 A3

- (51) International Patent Classification⁷: **F41H 11/16**
- (21) International Application Number: PCT/GB00/04203
- (22) International Filing Date:
2 November 2000 (02.11.2000)
- (25) Filing Language: English
- (26) Publication Language: English
- (30) Priority Data:
9925851.9 2 November 1999 (02.11.1999) GB
- (71) Applicant (for all designated States except US): **J R FRENCH LIMITED** [GB/GB]; 19 Epping Drive, Melton Mowbray, Leicestershire LE13 1UH (GB).
- (72) Inventor; and
(75) Inventor/Applicant (for US only): **FRENCH, John, Robert** [GB/GB]; 19 Epping Drive, Melton Mowbray, Leicestershire LE13 1UH (GB).
- (74) Agent: **POWELL, Timothy, J.**; Eric Potter Clarkson, Park View House, 58 The Ropewalk, Nottingham NG1 5DD (GB).
- (81) Designated States (*national*): AE, AG, AL, AM, AT, AU, AZ, BA, BB, BG, BR, BY, BZ, CA, CH, CN, CR, CU, CZ, DE, DK, DM, DZ, EE, ES, FI, GB, GD, GE, GH, GM, HR, HU, ID, IL, IN, IS, JP, KE, KG, KP, KR, KZ, LC, LK, LR, LS, LT, LU, LV, MA, MD, MG, MK, MN, MW, MX, MZ, NO, NZ, PL, PT, RO, RU, SD, SE, SG, SI, SK, SL, TJ, TM, TR, TT, TZ, UA, UG, US, UZ, VN, YU, ZA, ZW.
- (84) Designated States (*regional*): ARIPO patent (GH, GM, KE, LS, MW, MZ, SD, SL, SZ, TZ, UG, ZW), Eurasian patent (AM, AZ, BY, KG, KZ, MD, RU, TJ, TM), European patent (AT, BE, CH, CY, DE, DK, ES, FI, FR, GB, GR, IE, IT, LU, MC, NL, PT, SE, TR), OAPI patent (BF, BJ, CF, CG, CI, CM, GA, GN, GW, ML, MR, NE, SN, TD, TG).
- Published:**
— with international search report
- (88) Date of publication of the international search report:
20 September 2001
- For two-letter codes and other abbreviations, refer to the "Guidance Notes on Codes and Abbreviations" appearing at the beginning of each regular issue of the PCT Gazette.

(54) Title: **BLADES FOR DIGGING ASSEMBLIES, RELATED APPARATUSES AND METHODS FOR USE THEREOF**

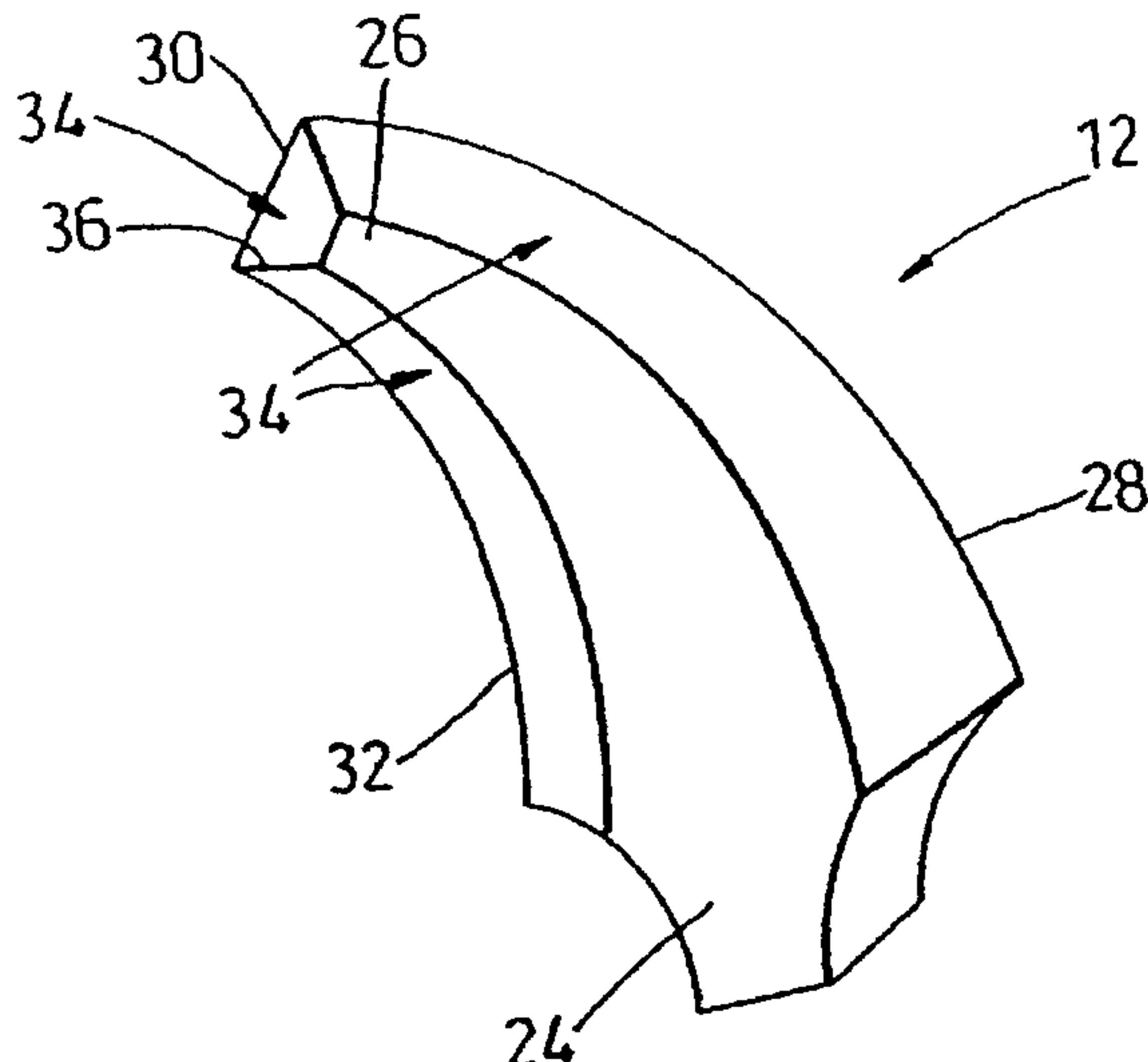

(57) **Abstract:** A blade (12) for a digging assembly comprises a base portion (24) and a terminal portion (26) remote from the base portion (24). The base portion (24) is wider than the terminal portion (26), and the blade tapers in width between the base and terminal portions (24, 26). First, second and third sharpened edges (28, 30, 32) are provided on the blade (12), each having flanks (34) that subtend an angle of at least 90°. Each of the flanks (34) are skewed in relation to the respective flanks (34) of the other edges. The orientation of the flanks (34) of the sharpened edges (28, 30, 32) enables the blade (12) to exhibit a lifting effect when it is rotated through material on an axis in a digging assembly.

WO 01/33158 A3

**A BLADE FOR A DIGGING ASSEMBLY, AND RELATED
APPARATUSES**

This invention relates to a blade for a digging assembly. Such as a digging
5 assembly and related apparatuses are disclosed in our co-pending UK Patent
Application No. GB9901997.8.

The invention also relates to a moveable vehicle including a grinding hopper and
a digging assembly such as the ones disclosed herein and in GB9901997.8.
10 Digging assemblies and apparatuses such as these are useful in the clearance of
landmines and other unexploded ordnance.

According to an aspect of the invention, a blade for use in a digging assembly
comprises:

- 15 (a) a base portion and a terminal portion remote from the base portion,
the base portion being wider than the terminal portion and the blade
tapering in width between the base and terminal portions;
- (b) a first, sharpened, arcuate edge, extending between the base and
terminal portions of the blade;
- 20 (c) a second sharpened edge defined by the terminal portion; and
- (d) a third, sharpened edge extending between the base and terminal
portions of the blade, each of the first, second and third edges having flanks that
between them subtend an angle of at least 90°, each of the flanks being skewed in
relation to the respective flanks of the other edges.

25

A blade according to this aspect of the invention can be mounted at its base on a
rotatable shaft in a digging assembly, in either of two orientations. In a first
orientation, rotation of the rotatable shaft in a predetermined direction

causes the blade to rotate about the axis of the shaft so that its first edge leads, followed by its second and third edges respectively. In the second orientation, rotation of the rotatable shaft in the predetermined direction causes the blade to rotate about the axis of the shaft so that its third edge
5 leads, followed by its second and first edges respectively.

In use a digging assembly such as the ones disclosed herein and in GB9901997.8 may be lain on or inserted into the soil of a minefield or battle area and driven forwardly e.g. by means of a pushing or pulling vehicle.
10 When a blade according to the invention is mounted in the first orientation on the rotatable shaft of the digging assembly, rotation of the shaft in a predetermined direction causes the first, sharpened edge of the blade to cut through soil and e.g. tree and plant roots, tripwires and cables thereby freeing any unexploded ordnance such as mines. The trailing second and
15 third, sharpened edges then follow the first, sharpened edge through the cut material.

The angle subtended by the flanks of the first, second and third edges of the blade, the relative orientation of the flanks, and the comparatively wide base
20 portion of the blade, define comparatively broad flanks on the first and third edges of the blades. As the third, sharpened edge trails the first sharpened edge through the cut material and other fragments in the soil, the flanks of the third edge provide a lifting effect. This allows any solid objects to be lifted to the surface of the minefield, from where they can be readily
25 removed and destroyed.

If roots or any other vegetation become wrapped around the rotatable shaft in the digging assembly, the rotatable shaft can be rotated in a reverse

direction. This causes the third sharpened edge to cut through the roots or vegetation around the shaft, so removing the entanglement around the shaft.

When a blade according to the first aspect of the invention is mounted in the second orientation on the rotatable shaft of a digging assembly, rotation of
5 the rotatable shaft in the predetermined direction in the digging assembly causes the third sharpened edge to cut through the soil etc. The trailing second and first edges follow through the cut material, and the orientation of the flanks of the first edge causes the cut material and any solid objects to be
10 lifted to the surface.

In an embodiment of this aspect of the invention, the flanks of the second, sharpened edge of the blade subtend an angle of 90° . The flanks of the first and third sharpened edges may also subtend an angle of 90° .

15

In other embodiments, the flanks of the first and/or third sharpened edges of the blade are concave.

The depth of the flanks of the second sharpened edge, when measured along
20 a line perpendicular to the length of the second sharpened edge, is preferably 25mm.

In a preferred embodiment of this aspect of the invention a chisel edge is provided at each of the junctions between the flanks of the second and third
25 edges of the blade.

The provision of the chisel edges is advantageous when the blade is used in a digging assembly that is being driven through rocky or stony ground. In

such use, the blade is mounted on the rotatable shaft of the digging assembly in the second orientation. Rotation of the rotatable shaft in the predetermined direction then causes the third sharpened edge of the blade to cut through the soil, and the location of the chisel edges is such that during this rotation the chisel edges are also leading edges. Hence the chisel edges can split and chop rocks and stones that are encountered by the blade.

The second sharpened edge follows the chisel edges and cuts material that has been split or chopped by the chisel edges. Finally the first edge follows through the split, chopped and cut material, the orientation of the flanks acting to support the cut material for lifting.

The length of each of the chisel edges, measured along each of the junctions between the flanks of the second and third edges of the blade, may be any value but in a preferred embodiment is 25mm.

The width of the base portion of the blade may be any value but in a preferred embodiment is 75mm.

According to a second aspect of the invention, a blade for use in a digging assembly includes three or more limb members, each limb member including:

- (a) a base portion and a terminal portion remote from the base portion, the terminal portion being wider than the base portion and each of the limb members tapering in width between the terminal and base portions;
- (b) a first, sharpened, arcuate edge extending between the base and terminal portions;

- (c) a second, sharpened, arcuate edge defined by the terminal portion;
and
- (d) a third, sharpened, arcuate edge extending between the terminal and
base portions;
- 5 wherein the three or more limb members meet and are joined together at
their base portions so that they extend away from a central region of the
blade at an equal distance to each other.

A blade according to this aspect of the invention may be mounted on a
10 rotatable shaft in a digging assembly by passing the rotatable shaft through
the central region of the blade.

The number of limbs is determined by the size of the cutting blades.

15 In preferred embodiments, all of the perimeter edges of the blade (apart
from those used for securing the blade) are sharpened. In combination with
the configuration of the limb members of the blade, such sharpened edges
create a continuous cutting action when the blade is rotated on a rotatable
shaft in a digging assembly.

20

Like the blade of the first aspect of the invention, a blade according to the
second aspect of the invention brings solid and large objects, such as stones
or unexploded ordnance, to the surface when it is used in a digging
assembly being driven through the soil.

25

A digging assembly including one or more blades according to the second
aspect of the invention may include a guillotine member associated with the
or each blade. The guillotine members may each be mounted in the digging

assembly so as to extend parallel to an associated said blade and are each offset slightly to one side therefrom. The said blades are each moveable relative to an associated guillotine member. In use, rotation of each blade past an associated said guillotine member creates a guillotine effect.

5

When a digging assembly including one or more blades and associated guillotine members is driven through the soil of a minefield or battlefield, the guillotine action of the blades, passing the guillotine members, cuts material such as barbed wire, razor wire and plant roots and prevents it from becoming wrapped around the rotatable shaft of the digging assembly.

As well as including one or more guillotine members, a digging assembly including one or more blades according to the second aspect of the invention may also include one or more tines mounted on the rotatable shaft. The or each tine may extend from and along the rotatable shaft, interconnecting adjacent pairs of the said blades.

When the digging assembly is driven through the soil of a minefield or a battlefield, the rotatable shaft rotates the blades through the soil. During such movement the shaft passes close to the top surface of the soil. The soil resists rotation and movement of the shaft as the digging assembly moves forwards, i.e. the shaft may dig into soil lifted in front of the blades and prevent the digging assembly moving forwards. The or each tine on the rotatable shaft reduces the pressure required to force the shaft through the soil. The tines help to break up and move the soil in front of the blades, lifting loosened soil and objects over the top of the shaft and allowing the shaft and the digging assembly to move forward unhindered. The tines also assist lifting and raising of relatively large objects to the surface of the soil.

In embodiments wherein the digging assembly includes an auger, the tines may move soil towards the auger during rotation of the shaft. 30.01.2002

95

5 The provision of such tines in the digging assembly means that it is possible to use a relatively low powered vehicle to drive the digging assembly through the soil of, for example, a minefield or battlefield.

The tines may vary in shape in dependence on the conditions in which the digging assembly is used.

10

A digging assembly may include a number of blades according to the second aspect of the invention. The precise number of blades, and the distance between the blades on the rotatable shaft, is dependent upon the amount and size of debris that is likely to be found in soil that the digging assembly is to be driven through. The number of, and spacing between, the blades is chosen accordingly. Similarly the diameter of the or each blade, and hence the length of each of the limb members of the or each blade used in a digging assembly, is dependent upon the depth of cut that is required from the digging assembly.

20

According to a third aspect of the invention, a moveable vehicle for clearing unexploded ordnance from soil comprises:

- (a) a digging assembly that is operable to loosen debris and lift it to a soil surface for conveyance via a conveyor path; and
- 25 (b) a conveyor for conveying material from the digging assembly and including a magnet for removing ferrous debris and a sieve for removing loose or small particles from the material, characterised in that the vehicle includes a hopper open at one end and having therein one or more moveable grinding elements for grinding, to a predetermined size, material conveyed to the hopper, the conveyor conveying material to the hopper and the sieve removing loose or

30

small particles before the conveyed material reaches the hopper.

The conveyor arrangement may include a conveyor belt provided with a magnetic roller at an extremity thereof. This allows any ferrous debris
5 contained within material being transported on the conveyor belt to be removed.

The magnetic roller may be a roller that includes a permanent magnet or an electromagnet.

10

The conveyor arrangement may also include a perforated conveyor belt. Small and loose particles contained in material conveyed on the conveyor belt may then fall through the perforations before the material reaches the
hopper.

15

The digging assembly may include a blade according to the first or second aspect of the invention, and preferably includes a plurality of blades according to the first or second aspect of the invention. In such embodiments, the digging assembly may include a guillotine member
20 adjacent one or more said blades, and may also include one or more tines mounted on its rotatable shaft adjacent one or more said blades.

The grinding hopper may include a plurality of pivotable hammers and one or more back plates.

25

There may be e.g. a single articulated metal back plate; or e.g. two individual plates that follow reciprocating paths in front of, or on either side of, the pivotable hammers.

30 The plurality of hammers may be mounted on one or more rotating flywheels.

The grinding hopper may optionally include a grille between the pivotable hammers and the or each back plate. Such a grille can be used to ensure that only particles greater than the size of the holes in the grille are kept within the grinding hopper, allowing smaller particles to drop under gravity through the grille. This can be used to determine the size of the particles produced by the hopper, because as soon as the particles become small enough, they will pass through the grille away from the pivotable hammers.

10 The distance between the plurality of pivotable hammers and the back plate may be adjustable. This allows the resultant size of the particles produced by the hopper to be altered.

According to a fourth aspect of the invention there is provided a method of clearing a minefield comprising the steps of:

- 15 (i) driving a digging assembly propelled by a vehicle for clearing unexploded ordnance from soil through soil of the minefield and collecting loosened debris that is consequently lifted to the surface of the soil and conveying the loosened debris using a conveyor
20 operatively associated with the said vehicle;
- (ii) separating ferrous material from the debris using a magnet and collecting the ferrous material in a collecting receptacle; and
- (iii) separating small and loose non-ferrous particles from the non-ferrous debris using a sieve for deposit on the soil; the method being
25 characterised by the step of:
- (iv) grinding remaining non-ferrous debris in a grinding hopper to a predetermined size for deposit on the soil.

The method may further include the steps of:

- (v) observing the digging assembly;
- (vi) halting the digging assembly when one or more objects larger than a predetermined size is lifted to the surface of the soil by the digging assembly; and
- 5 (vii) removing the one or more objects before recommencing operation of the digging assembly.

According to a fifth aspect of the invention there is provided a method of clearing ordnance from ordnance-infested soil comprising the steps of: moving a
 10 pair of mutually spaced, parallel blades having parallel cutting edges simultaneously in two directions through ordnance-infested soil whereby to cut a segment of the soil; and simultaneously moving a tine or paddle member, that lies between the blades and is spaced from the said cutting edges, in the said two
 15 directions whereby to move the said soil segment, at least one of the said directions of movement being such as to cause the blades and/or the tine or paddle member to lift the segment and ordnance therein, the spacing between the blades permitting conveying of particles of the segment, of less than a predetermined size, away from the blades; while lifting particles of the segment of greater than the said size to an uppermost part of the ordnance-infested soil
 20 near the blades.

Preferred embodiments of the invention will now be described, by way of non-limiting examples, with reference to the accompanying drawings in which:

25 Figure 1 is a side view of a digging assembly according to the invention;

Figure 2 is a perspective view of a digging assembly similar to that shown in Figure 1;

Figure 3 is a perspective view of a blade according to the invention for use in a digging assembly such as those shown in Figures 1 and 2;

Figure 4 is a perspective view of a further blade according to the invention for
5 use in a digging assembly such as those shown in Figures 1 and 2;

Figure 5a is a schematic view of a number of the blades shown in Figure 4 mounted on a rotatable shaft in a digging assembly such as that shown in Figures 1 and 2;

Figure 5b shows the blade of Figure 4 mounted on a rotatable shaft in combination with a plurality of tines;

5 Figures 5c and 5d show individual tines according to embodiments of the invention;

Figure 5e shows the blade of Figure 4 during forward movement of the digging assembly of Figure 5a;

10 Figure 6 is a schematic side elevational view of a moveable vehicle according to the invention;

Figure 7 is a perspective view of a moveable vehicle, according to the invention, and similar to that shown in Figure 4; and

15

Figures 8a and 8b are perspective views of internal details of a grinding hopper in accordance with the invention.

20 Digging assemblies 10, such as the digging assemblies shown in Figures 1 and 2, are described in detail in our co-pending UK Patent Application No. GB9901997.8.

25 The digging assembly 10 shown in Figures 1 and 2 includes a plurality of blades 12 mounted on a rotatable shaft 14. When the digging assembly 10 is driven through soil in a minefield, the rotatable shaft 14 causes the blades 12 to rotate through the soil. Sharpened edges on the blades 12 cut through the soil and any other material such as plant roots and wires. Solid objects such as stones or unexploded ordnance are brought to the surface of the soil

by the rotating blades. Here they are scooped up and collected by one of a number of buckets 16 passing around a conveyor path 18 on the digging assembly 10.

- 5 The buckets 16 move around the conveyor path 18 carrying objects they have collected from the surface of the soil, until they reach an uppermost point 20 on the conveyor path 18. At uppermost point 20, the buckets 16 tip and drop their loads into or onto a collecting member.
- 10 The buckets 16 then move further around the conveyor path 18 to a position at which they are once again available to collect objects that have been lifted to the surface by the blades 12.

A camera 22 may be provided to observe the blades 12 and the buckets 16
15 travelling around the conveyor path 18.

The camera 22 allows the digging assembly 10 to be operated remotely.

If unexploded ordnance collected by one of the buckets 16 is observed, via
20 the camera 22, by an operator, the digging assembly 10 can be halted, and the unexploded ordnance disposed of safely.

In other embodiments, a ribbed conveyor belt may replace the buckets 16. In such embodiments, spaced ribs on the conveyor belt may collect objects
25 lifted to the surface by the blades 12, each rib transporting its load to the uppermost point 20 on the conveyor path 18 before dropping it into or onto the collecting member.

A blade 12 according to the invention, and suitable for use in a digging assembly 10, such as those shown in Figures 1 and 2, is shown in Figure 3.

The blade 12 includes a base portion 24 and a terminal portion 26 remote
5 from the base portion 24. The base portion 24 is wider than the terminal portion 26, the blade 12 tapering in width between the base portion 24 and the terminal portion 26.

The width of the blade 12 is proportional to the length of the blade. Thus
10 when the depth of the desired cut of the blade 12 is 250mm, the width of the base portion 24 of the blade 12 is 75mm.

The blade 12 includes a first arcuate edge 28 that extends between the base
portion 24 and the terminal portion 26. The first edge 28 is sharpened and,
15 in the Figure 3 embodiment, is convexly curved.

A second edge 30 extends from the first edge 28, across the terminal portion
26 of the blade 12. The second edge 30 is sharpened and, in the Figure 3
embodiment, is flat.

20

The blade 12 also includes a third arcuate edge 32 that extends from the
second edge 30 between the terminal portion 26 and the base portion 24.
The third edge 32 extends along an opposite side of the blade 12 to the first
edge 28. The third edge 32 is sharpened and, in the Figure 3 embodiment, is
25 concavely curved.

The three sharpened edges 28,30,32 have flanks 34 that between them
subtend an angle of at least 90°. On each side of the blade 12, the respective

flanks 34 of each of the edges 28,30,32 are skewed one relative to another.

The blade 12 may be secured on a rotatable shaft 14 of a digging assembly 10 at its base portion 24, in one of two orientations. In either of the orientations, the plane of the blade 12 is generally perpendicular to the axis of the shaft 14.

When the blade 12 is mounted in a first orientation, rotation of the shaft 14, during normal forward movement of the digging assembly 10, rotates the blade 12 about the axis of the shaft, so that the first edge 28 leads and is followed by the second and third edges 30,32 respectively.

During such rotation the first edge 28 cuts through the soil and, for example, tree and plant roots, tripwires and cables, thereby freeing any unexploded ordnance such as mines. The trailing second and third edges 30,32 follow the first edge 28 through the cut material.

The angle subtended by the flanks 34 of the edges 28,30,32 of the blade 12, the relative orientation of the flanks 34; and the comparatively wide base portion 24 of the blade 12, define comparatively broad flanks 34 on the first and third edges 28,32. This means that as the third edge 32 trails the first edge 28 through the cut material, and other fragments in the soil, the flanks 34 of the third edge 32 provide a lifting effect.

Rotation of the shaft 14 may be reversed so that the third edge 32 leads, followed by the second and first edges 30,28 respectively. During such rotation the third edge 32 cuts, for example, any roots or vegetation that may have become wrapped around the shaft 14.

When the blade 12 is mounted in the second orientation, rotation of the shaft 14 during normal forward movement of the digging assembly 10 rotates the blade 12 about the axis of the shaft so that the third edge leads and is followed by the second and first edges 30,28 respectively.

5

During such rotation the third edge cuts through the soil etc. and the trailing second and first edges 30,28 follow through the cut material. The relative size and orientation of the flanks 34 of the first edge 28, as discussed earlier with reference to the first orientation, causes the cut material, and any solid objects, to be lifted to the surface.

10

The flanks 34 of the first edge 28 and the third edge 32 may optionally be concave.

15 The blade 12 shown in Figure 3 includes a chisel edge 36. The chisel edge 36 is located along the junction between the flanks 34 of the second edge 30 and the third edge 36. A chisel edge 36 is also located between the flanks 34 of the second edge 30 and the third edge 32 of the opposite side of the blade 12 to that shown in Figure 3.

20

In embodiments in which the blade 12 includes a chisel edge 36, the blade 12 may be mounted in the second orientation so that both the third edge 32 and the chisel edge 36 are leading edges during rotation of the shaft 14. This allows the chisel edge 36 to split and chop rocks encountered by the blade 25 12 during rotation about the axis of the shaft.

The second edge 32 follows the chisel edges and cuts the material that has been chopped by the chisel edge 36. The flanks 34 of the first edge 28 lift the cut material in a similar manner to that described earlier.

5 In preferred embodiments, the length of the chisel edge 36, measured along the junction between the second and third edges 30,32, is 25mm.

A further blade 12 according to the invention is shown in Figure 4. This blade 12 includes three limb members 38. Each limb member 38 has a base portion 40 and a terminal portion 42. The terminal portion 42 is wider than
10 the base portion 40, each of the limb members 38 tapering in width between the terminal portion 42 and the base portion 40.

Each limb member 38 includes a first arcuate edge 44 that extends between the base portion 40 and the terminal portion 42. The first edge 44 is
15 sharpened and, in the Figure 4 embodiment, is concavely curved.

A second edge 46 extends from the first edge 44 across the terminal portion 42 of each of the limb members 38. The second edge 46 is also sharpened and, in the Figure 4 embodiment, is convexly curved.

20

Each limb member 38 also includes a third arcuate edge 48 that extends between the terminal portion 42 and the base portion 40. The third edge 48 extends along an opposite side of each of the limb members 38 to the first edge 44. The third edge 48 is sharpened and, in the Figure 4 embodiment, is
25 concavely curved.

The three limb members 38 meet and are joined together at their base portions 40, at a central region 50 of the blade 12. The limb members 38

extend away from the central region 50 at an equal distance apart from each other. In the embodiment shown in Figure 4, the limb members 38 lie in generally the same plane as each other.

5 The blade 12 may be secured on a rotatable shaft 14 in a digging assembly 10, such as those shown in Figures 1 and 2, by passing the shaft 14 through the centre point 50 of the blade 12 and fixing the blade 12 and the shaft 14 to one another. Rotation of the shaft 14 then causes the limb members 38 to rotate about the axis of the shaft 14.

10

The sharpened edges 44,46,48 of the limb members 38 may form a contiguous series of sharpened edges around the perimeter of the blade 12.

15 When the blade 12 of Figure 4 is used in a digging assembly 10, a guillotine block 52 may be positioned in the digging assembly 10 so that when the blade 12 is rotated by the shaft 14, it passes close to the guillotine block 52.

20 The arrangement shown in Figure 5a shows a number of the blades 12 of Figure 4 mounted on a rotatable shaft 14. A number of guillotine blocks 52 are positioned in the digging assembly 10 so that each of the guillotine blocks 52 is fixed relative to the blades 12 and lies parallel to, and offset to one side of, an adjacent one of the blades 12. When the shaft 14 rotates, each of the blades 12 passes close by one of the guillotine blocks 52. If items such as barbed wire, trip wire or plant roots are picked up by the limb
25 members 38 of the blades 12, the action of the blades 12 passing the guillotine blocks 52 cuts the items so that they do not become wrapped around the rotatable shaft 14.

The rotatable shaft 14 in Figure 5a also includes a number of tines 54 between adjacent blades 12. The tines 54 extend along the length of, and project outwardly from, the shaft 14 between adjacent blades 12. The tines 54 are fixed relative to shaft 14, whereby the tines 54 rotate with the blade
5 during rotation of the shaft 14.

Figure 5b shows a blade 12 having six limbs 38 mounted on a rotatable shaft 14 in combination with three tines 54. The tines 54 are mounted on, and equidistantly spaced apart about, the shaft 14, adjacent the blade 12.

10

The tines 54 may vary in shape and size depending on the varying conditions in which the digging assembly 10 is used. Figures 5c and 5b show two different types of tine 54.

15 The tine 54 shown in Figure 5c is generally T-shaped having perpendicular support and crossbar members 55,57. The tine 54 may be secured to a rotatable shaft 14 along a generally straight edge 59 provided at the free end of the support member 55.

20 The tine 54 shown in Figure 5d is an arcuately curved member that tapers in cross-sectional width as it extends from a base portion 63 towards its terminal portion 65. The tine 54 may be secured to a rotatable shaft 14 along a generally straight edge 67, extending along the base portion 63, such that that the terminal portion 65 is a leading edge during rotation of the shaft 14.

25

During forward movement of a digging assembly 10 including the blades 12, guillotine members 52 and tines 54 of Figure 5a, the shaft 14 rotates in

order to rotate the blades 12 in an anti-clockwise direction, as shown in Figure 2.

5 Rotation of the blades 12 in this manner causes the blades 12 to cut a slice of soil as they pass through the soil. The direction of rotation of the blades 12 relative to the direction of movement of the digging assembly 10, together with the trailing edges of the blades 12, lifts the slice of soil to form a wave 69 (Figure 5e) of soil that is pushed forward in front of the blades 12.

10

The lifting effect of the blades 12 also lifts buried objects, such as unexploded ordnance and landmines 71, to the surface of the soil so that they are brought to the surface of the wave of soil.

15 Rotation of the shaft 14 also causes rotation of the tines 54 in the same direction as the blades 12. The tines 54 assist lifting of the soil and any buried objects encountered by the blades 12. Such rotation also lifts any loosened soil and small objects, such as small, unexploded, ordnance or other debris, over the shaft 14 for collection by a bucket 16 of the digging
20 assembly 10. The tines 54 thereby reduce the amount of soil and debris in front of the blades and assist movement of the shaft 14 through the soil in the direction of movement of the digging assembly 10.

25 Any loose soil or small objects that drop from the wave, in front of the blades 12, rather than being lifted over the shaft 14, are lifted again by the rotating blades 12 and tines 54 as they pass through the soil. Such loose material and objects are thereby propelled in front of the blades 12 until they are lifted over the shaft 14 for collection by one of the buckets 16.

The size of the objects that the tines 54 can lift over the shaft 14 is determined by the separation A between adjacent blades 12 mounted on the shaft 14. This is because the tines 54 are generally relatively shorter in length than the blades 12 and therefore the lifted objects must pass between
5 adjacent blades 12.

This allows adjustment of the digging assembly 10 to ensure that unexploded ordnance larger than a predetermined size is not picked up by the buckets 16 of the digging assembly 10. As such objects cannot be lifted
10 over the shaft 14, they are propelled forward on the wave of soil created in front of the blades 12.

The camera 22 provided in the digging assembly 10, for observing the blades 12 and the buckets 16, allows an operator to judge whether to halt the
15 digging assembly 10 if a large object, such as an unexploded landmine, is brought to the surface and is carried on the wave of soil in front of the blades 12. This allows safe removal and/or detonation of the object before operation of the digging assembly 10 recommences. The camera 22 thereby provides means by which the digging assembly 10 can be operated
20 remotely.

A moveable vehicle 56 according to the invention is shown in Figures 6 and 7.

25 Moveable vehicle 56 includes a digging assembly 10, a conveyor arrangement 58 and a grinding hopper 60.

The digging assemblies shown in Figures 1 and 2, and in co-pending patent application no. GB9901997.8, are suitable for use as the digging assembly 10 of Figure 6.

- 5 In the embodiment shown, the conveyor arrangement 58 includes a first conveyor 62 and a second conveyor 64.

The first conveyor 62 comprises an endless, flexible belt 66 moveably entrained about two spaced apart, rotatable rollers 68,70. Roller 68 is
10 positioned below an upper end of the digging assembly 10. The conveyor belt 66 extends around the first roller 68 and extends horizontally from the first roller 68 to the second roller 70 at a position remote from the digging assembly 10.

- 15 Roller 70 includes a magnet that can be a permanent magnet or an electromagnet.

Like the first conveyor 62, the second conveyor 64 comprises an endless, flexible conveyor belt 72 moveably entrained around two spaced apart,
20 rotatable rollers 74,76.

Roller 74 is positioned beside, and slightly below, roller 70 of the first conveyor 62. The second conveyor belt 72 extends in the same direction as the first conveyor belt 66. It extends upwardly and around roller 74, and
25 horizontally away from roller 74 towards the second roller 76, remote from the first conveyor 62.

The second conveyor belt 72 includes numerous perforations, that are each of the same size and allow particles that are smaller than a predetermined size to fall through the belt 72 under gravity.

5 Two television cameras 22,78 are provided at elevated positions above the moveable vehicle 56. The cameras 22,78 can tilt, swivel and zoom. They allow observation of the material being transported through the moveable vehicle 56, as well as aiding the control of the steering of the vehicle 56. In particular, one of the cameras 22 observes the material being lifted by the
10 digging assembly 10, whilst the other camera 78 concentrates on the material conveyed through the rest of the vehicle.

Material that is lifted by the buckets 16 of the digging assembly 10 is dropped onto the first end 68a of the first conveyor 62 when the buckets 16
15 reach the uppermost point 20 of the conveyor path 18.

The thus deposited material is transported towards roller 70, away from the digging assembly 10. As the material approaches roller 70, any ferrous debris contained within the material is attracted by the magnet, incorporated
20 into roller 70, towards the area of conveyor belt 66 surrounding roller 70.

As the conveyor belt 66 travels around roller 70 any non-ferrous material is transported over the end of the first conveyor 62 and falls under gravity onto a first end 74a of the second conveyor 64.

25

The ferrous debris does not fall off of the end of the first conveyor 62 with the non-ferrous debris due to the attractive magnetic force provided by roller 70. Consequently the ferrous debris remains in contact with the conveyor

belt 66 as it travels around roller 70. This effectively separates any ferrous debris from other material being conveyed through the moveable vehicle 56.

5 The ferrous debris remains in contact with the conveyor belt 66 until the ferrous debris has moved a predetermined distance away from the second roller 70, back towards the first roller 68. At this point, the magnetic force is too weak to keep the ferrous debris in contact with the belt 66. The ferrous debris thence falls under gravity from the belt 66, and is guided to a collection receptacle 80 by a chute 82.

10

This allows any unexploded ordnance, such as small antipersonnel mines, to be separated from material being conveyed through the moveable vehicle 56 in order to allow the unexploded ordnance to be disposed of safely. Collection of any ferrous debris also ensures that it does not make its way
15 back to the soil. It is a UN requirement that metal fragments are removed from a minefield to allow a minefield audit to be carried out using, amongst other things, metal detection equipment. The removal of ferrous debris cuts down the number of false alarms that would otherwise be generated.

20 The non-ferrous material that falls onto the first end 74a of the second conveyor 64 is transported away from the first conveyor 62 towards the second roller 76 of the second conveyor 64. Since the second conveyor belt 72 is perforated, particles smaller than a predetermined size fall under gravity through the conveyor belt 72.

25

When the non-ferrous material that remains on the second conveyor belt 72 reaches the second roller 76, it is transported over the second end 76a of the second conveyor 64 and falls under gravity into the grinding hopper 60.

Internal details of a grinding hopper, according to the invention, are shown in Figures 8A and 8B.

The grinding hopper includes a back plate 84, which in Figure 8A is shown
5 as an articulated metal back plate passing around two vertically spaced apart rollers 86,88.

A number of flywheels 90 are provided within the area enclosed by the backplate 84. A plurality of pivotable hammers 92 are mounted on each of
10 the rotatable flywheels 90, as shown in Figure 8B.

When material is fed into the top of the grinding hopper, it is crushed or broken between the hammers 92 and the back plate 84.

15 The hammers 92 are pivotable in order to allow them to bounce off extremely hard materials. The hammers may be provided in various shapes and sizes, depending on the nature of the material and soil structure of the cut material being fed into the grinding hopper.

20 The back plate 84 is moveable in order to prevent wet material that may be fed into the grinding hopper from causing a blockage.

In other embodiments two or more individual plates, that are moveable along reciprocating paths on either side of the rotating flywheels 90, may
25 replace the articulated metal back plate 84

The grinding hopper may include a variety of flywheel 90 and pivotable hammer 92 combinations. The flywheel/hammer assemblies can be moved

towards or away from the back plate 84 to allow for different sizes of particle to be produced, and to allow for wear on the pivotable hammers 92.

The size of the particles produced by the grinding hopper can also wholly or
5 partly be determined by the size of the holes provided in a grille 94.

The grille 94 is optional. When present it is located between the pivotable hammers 92 and the back plate 84. The provision of the grille 94 between the hammers 92 and the back plate 84 means that particles smaller than a
10 predetermined size fall under gravity through holes in the grille 94.

Particles that are larger than the predetermined size of the holes in the grille 94 are retained between the pivotable hammers 92 and the grille 94 so that they are crushed and broken down further, until they are small enough to
15 fall under gravity through the grille 94, away from the hammers 92.

The grille 94 may be produced from hardened metal.

**THE EMBODIMENTS OF THE INVENTION IN WHICH AN EXCLUSIVE
PROPERTY OR PRIVILEGE IS CLAIMED ARE DEFINED AS FOLLOWS:**

1. A blade (12) for use in a digging assembly (10) comprising:
 - 5 (a) a base portion (24) and a terminal portion (26) remote from the base portion (24), the base portion (24) being wider than the terminal portion (26) and the blade tapering in width between the base and terminal portions;
 - 10 (b) a first, sharpened, arcuate edge (28), extending between the base and terminal portions of the blade (12);
 - (c) a second sharpened edge (30) defined by the terminal portion (26); and
 - 15 (d) a third, sharpened edge (32) extending between the base and terminal portions of the blade (12), each of the first, second and third edges (28,30,32) having flanks (34) that between them subtend an angle of at least 90°, each of the flanks (34) being skewed in relation to the respective flanks of the other edges.
2. A blade as claimed in Claim 1, wherein the flanks of the second,
20 sharpened edge (30) subtend an angle of 90°.
3. A blade as claimed in Claim 1 or Claim 2, wherein the flanks of each of the first and third, sharpened, arcuate edges (28,32) subtend an angle of 90°.
- 25 4. A blade as claimed in Claim 1 or Claim 2, wherein the flanks of at least one of the first and third, sharpened, arcuate edges (28,32) are concave.
5. A blade as claimed in Claim 4, wherein the flanks of each of the first and third, sharpened, arcuate edges (28,32) are concave.

6. A blade as claimed in any one of Claims 1 to 5, wherein the depth of the flanks (34) of the second, sharpened edge (30) when measured along a line perpendicular to the length of the second, sharpened edge is 25mm.

5

7. A blade as claimed in any one of claims 1 to 6, further including a chisel edge (36) at each of the junctions between the flanks of the second and third edges (30,32).

10 8. A blade as claimed in Claim 7, wherein the length of each of the chisel edges (36) is 25mm.

9. A blade as claimed in any one of Claims 1 to 8, wherein the width of the base portion (24) of the blade is 75mm.

15

10. A blade (12) for use in a digging assembly comprising three or more limb members (38), each limb member (38) including:

20

(a) a base portion (40) and a terminal portion (42) remote from the base portion (40), the terminal portion (42) being wider than the base portion (40) and each of the limb members (38) tapering in width between the terminal and base portions (40,42);

(b) a first, sharpened, arcuate edge (44) extending between the base (40) and terminal (42) portions;

25

(c) a second, sharpened edge (46) defined by the terminal portion (42);
and

(d) a third, sharpened, arcuate edge (48) extending between the base (40) and terminal (42) portions;

wherein the three or more limb members (38) meet and are joined together at their base portions (40) so that they extend away from a central region (50) of the blade at an equal distance apart from each other.

5 11. A blade as claimed in Claim 10, wherein the sharpened edges (44,46,48) of the limb members (38) form a contiguous series of sharpened edges around the perimeter of the blade (12).

10 12. A digging assembly (10) including one or more blades (12) each according to Claim 10, wherein a rotatable shaft (14) passes through the centre (50) of and is secured to the or each blade (12).

15 13. A digging assembly (10) according to Claim 12, further including a guillotine member (52) associated with the or each blade (12), the or each guillotine member (52) extending parallel to and displaced to one side of the or each blade (12).

20 14. A digging assembly according to Claim 12 or Claim 13, wherein the rotatable shaft (14) includes one or a number of tines (54) extending from and along the rotatable shaft (14) adjacent the or each blade (12).

15. A moveable vehicle (56) for clearing unexploded ordnance from soil, comprising:

25 (a) a digging assembly (10) that is operable to loosen debris and lift it to a soil surface for conveyance via a conveyor path; and

(b) a conveyor (62,64) for conveying material from the digging assembly (10) and including a magnet (70) for removing ferrous debris and a sieve (72) for removing loose or small particles from the material, characterised in that the vehicle includes a hopper (60)

open at one end and having therein one or more moveable grinding elements (92) for grinding, to a predetermined size, material conveyed to the hopper (60), the conveyor (62,64) conveying material to the hopper (60) and the sieve removing loose or small particles before the conveyed material reaches the hopper (60).

5

16. A moveable vehicle as claimed in Claim 15, wherein the conveyor arrangement includes a conveyor belt (66) provided with a magnetic roller (70) at an extremity thereof.

10

17. A moveable vehicle as claimed in Claim 16, wherein the magnetic roller (70) comprises a roller that includes a permanent magnet.

18. A moveable vehicle as claimed in Claim 16, wherein the magnetic roller (70) comprises a roller that includes an electromagnet.

15

19. A moveable vehicle as claimed in any of Claims 15 to 18, wherein the conveyor includes a perforated conveyor belt (72).

20. A moveable vehicle as claimed in any of Claims 15 to 19, wherein the digging assembly includes one or more blades (12) according to Claim 1 or any claim dependent therefrom.

20

21. A moveable vehicle as claimed in any of Claims 15 to 19, wherein the digging assembly includes one or more blades (12), each one or more blade comprising three or more limb members, each limb member (38) including:

25

- (a) a base portion (40) and a terminal portion (42) remote from the base portion (40), the terminal portion (42) being wider than the

base portion (40) and each of the limb members (38) tapering in width between the terminal and base portions (40,42);

(b) a first, sharpened, arcuate edge (44) extending between the base (40) and terminal (42) portions;

5 (c) a second, sharpened edge (46) defined by the terminal portion (42);
and

(d) a third, sharpened, arcuate edge (48) extending between the base (40) and terminal (42) portions;

wherein the three or more limb members (38) meet and are joined together at
10 their base portions (40) so that they extend away from a central region (50) of the
blade at an equal distance apart from each other.

22. A moveable vehicle as claimed in any one of Claims 15 to 19, wherein the
digging assembly includes one or more blades, each of the one or more blades
15 comprising three or more limb members, each limb member (38) including:

(a) a base portion (40) and a terminal portion (42) remote from the
base portion (40), the terminal portion (42) being wider than the
base portion (40) and each of the limb members (38) tapering in
width between the terminal and base portions (40,42);

20 (b) a first, sharpened, arcuate edge (44) extending between the base
(40) and terminal (42) portions;

(c) a second, sharpened edge (46) defined by the terminal portion (42);
and

(d) a third, sharpened, arcuate edge (48) extending between the base
25 (40) and terminal (42) portions;

wherein the three or more limb members (38) meet and are joined together at
their base portions (40) so that they extend away from a central region (50) of the
blade at an equal distance apart from each other, and the sharpened edges

(44,46,48) of the limb members (38) form a contiguous series of sharpened edges around the perimeter of the blade (12).

23. A moveable vehicle as claimed in Claim 21 or Claim 22, wherein the
5 digging assembly (10) is in accordance with any one of Claims 12 to 14.

24. A moveable vehicle as claimed in any of Claims 15 to 23, wherein the grinding hopper (60) includes a plurality of pivotable hammers (92) and a back plate (84).

10

25. A moveable vehicle as claimed in Claim 24, wherein the back plate (84) includes an articulated hardened metal back plate passing around two spaced apart rollers (86,88).

15 26. A moveable vehicle as claimed in Claim 24, wherein the back plate (84) includes two plates that follow reciprocating paths in front of or on either side of the pivotable hammers (92).

20 27. A moveable vehicle as claimed in any of Claims 24 to 26 wherein the plurality of pivotable hammers (92) are mounted on one or more rotating flywheels (90).

25 28. A moveable vehicle as claimed in any of Claims 24 to 27, wherein the grinding hopper (60) further includes a grille (94) between the plurality of pivotable hammers (92) and the back plate (84).

29. A moveable vehicle as claimed in any of Claims 24 to 28, wherein the distance between the plurality of pivotable hammers (92) and the back plate (84) is adjustable.

30. A method of clearing a minefield comprising the steps of:
- (i) driving a digging assembly (10) propelled by a vehicle for clearing unexploded ordnance from soil through soil of the minefield and collecting loosened debris that is consequently lifted to the surface of the soil and conveying the loosened debris using a conveyor operatively associated with the said vehicle;
 - (ii) separating ferrous material from the debris using a magnet and collecting the ferrous material in a collecting receptacle (80); and
 - (iii) separating small and loose non-ferrous particles from the non-ferrous debris using a sieve for deposit on the soil; the method being characterised by the step of:
 - (iv) grinding remaining non-ferrous debris in a grinding hopper to a predetermined size for deposit on the soil.
- 15 31. A method of clearing a minefield as claimed in Claim 30 further including the steps of:
- (v) observing the digging assembly (10);
 - (vi) halting the digging assembly when one or more objects larger than a predetermined size is lifted to the surface of the soil by the digging assembly (10); and
 - (vii) removing the one or more objects before recommencing operation of the digging assembly (10).
- 25 32. A method of clearing ordnance from ordnance-infested soil comprising the steps of:
- moving a pair of mutually spaced, parallel blades (12) having parallel cutting edges simultaneously in two directions through ordnance-infested soil whereby to cut a segment of the soil; and

simultaneously moving a tine or paddle member (54), that lies between the blades (12) and is spaced from the said cutting edges, in the said two directions whereby to move the said soil segment,

at least one of the said directions of movement being such as to cause the
5 blades (12) and/or the tine or paddle member (54) to lift the segment and ordnance therein, the spacing between the blades (12) permitting conveying of particles of the segment, of less than a predetermined size, away from the blades (12); while lifting particles of the segment of greater than the said size to an uppermost part of the ordnance-infested soil near the blades (12).

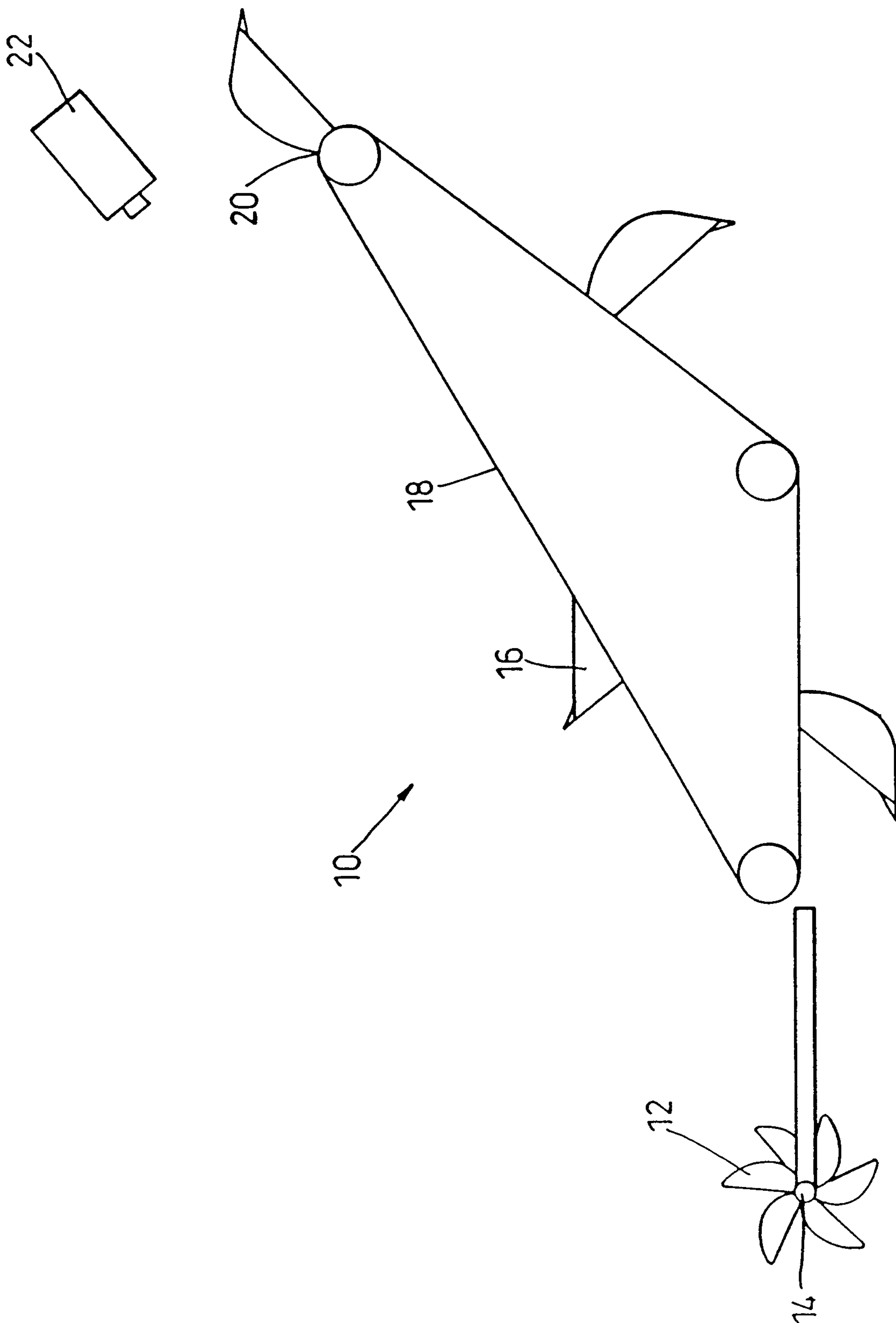

Fig. 1

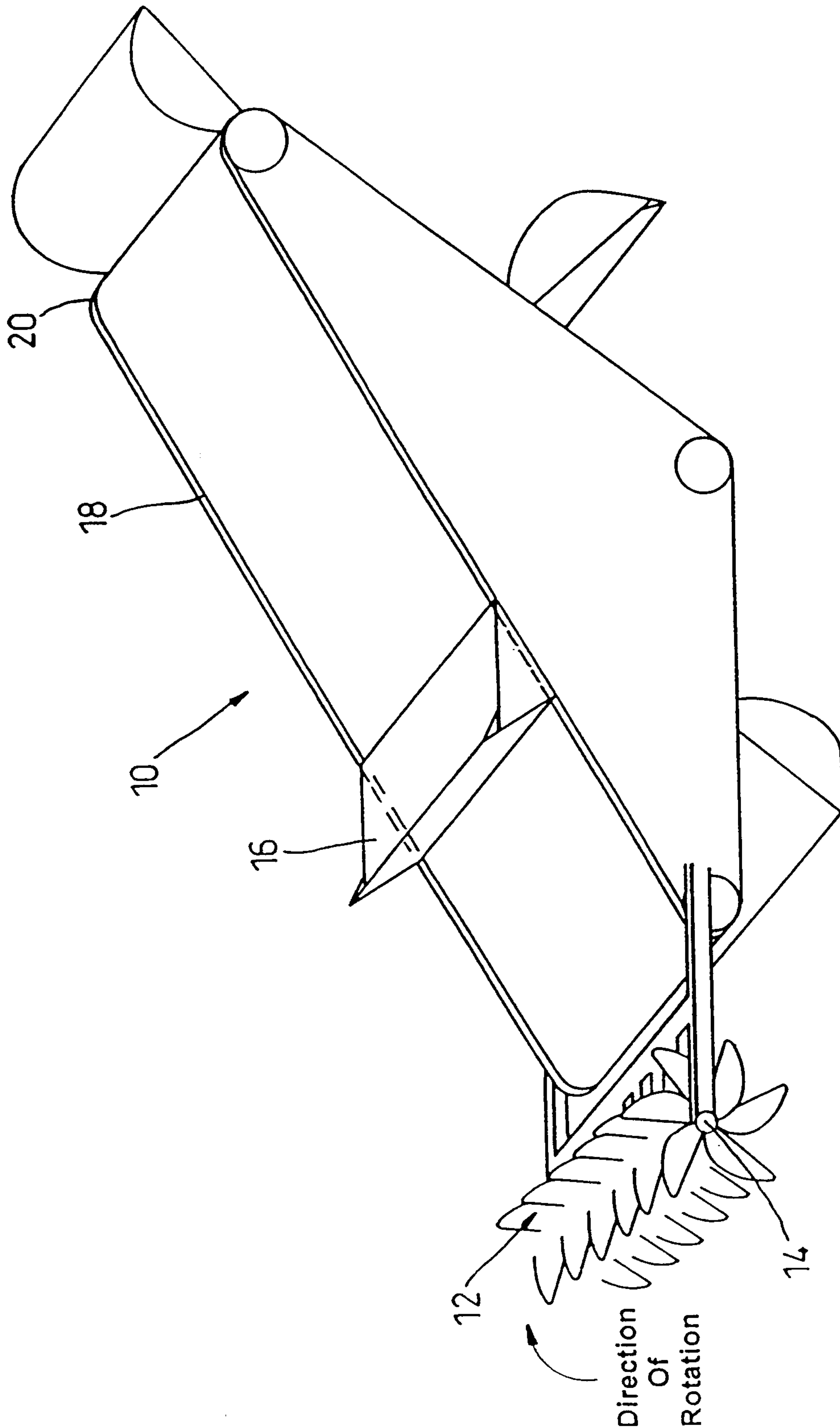

Fig. 2

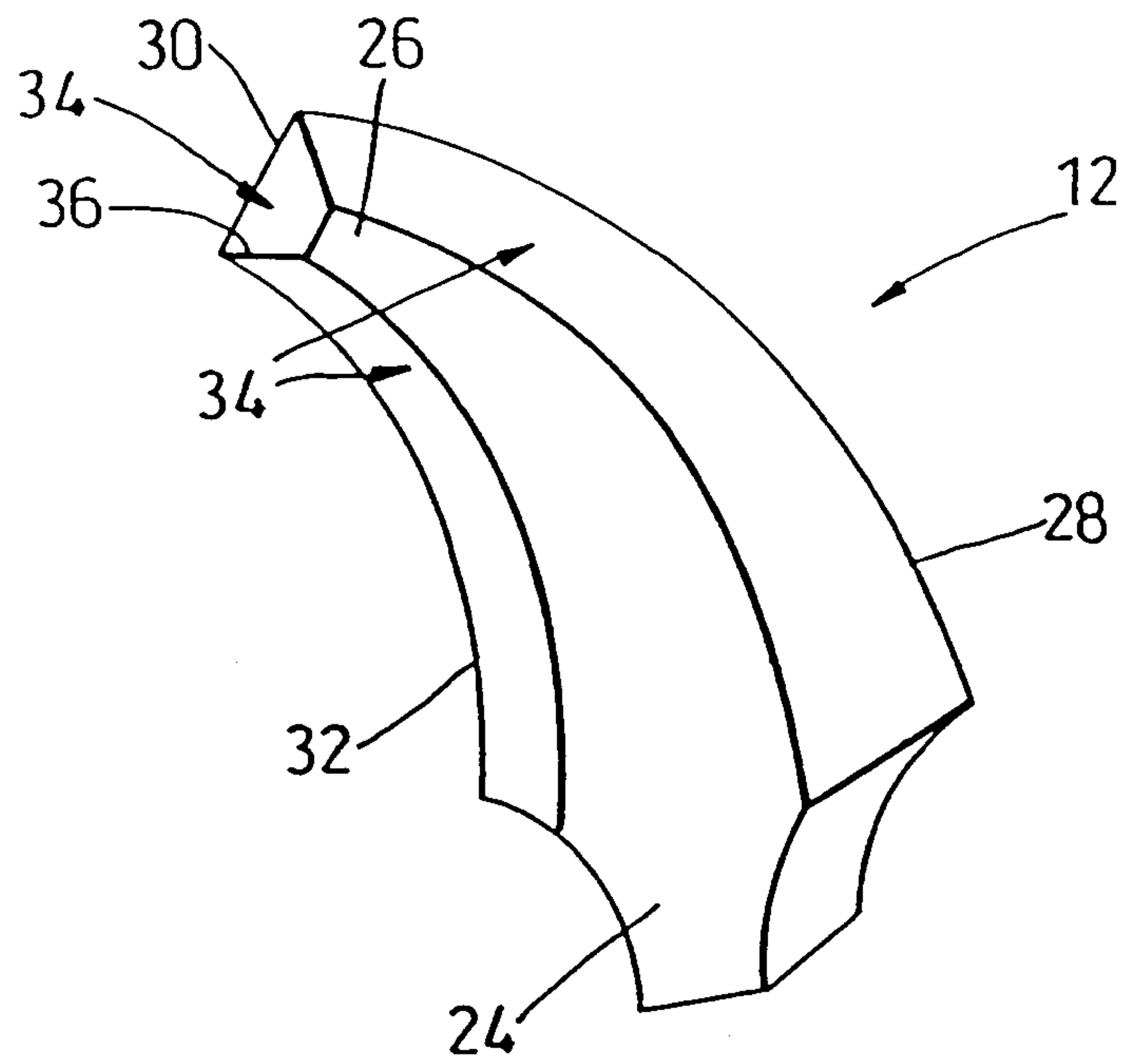

Fig. 3

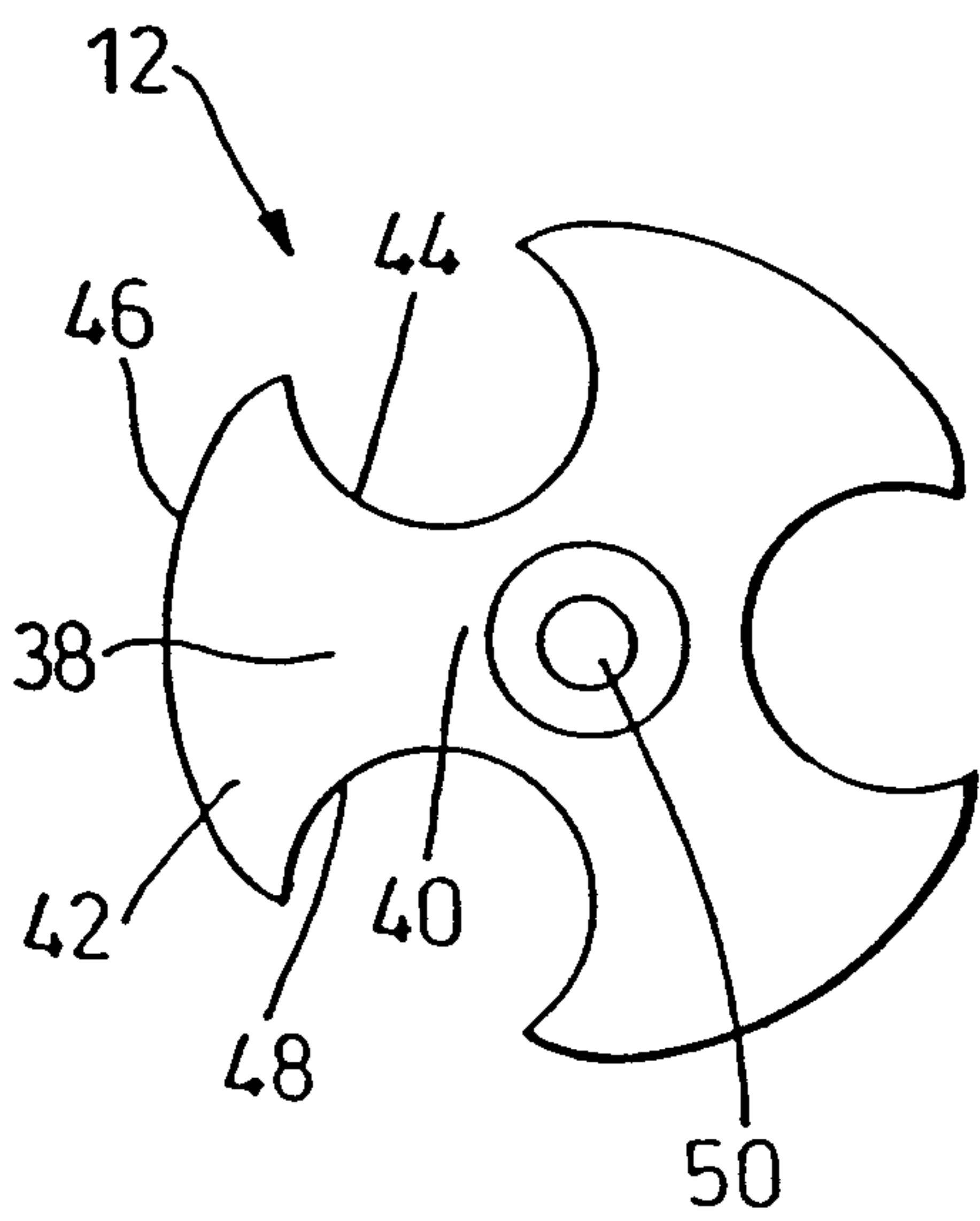

Fig. 4

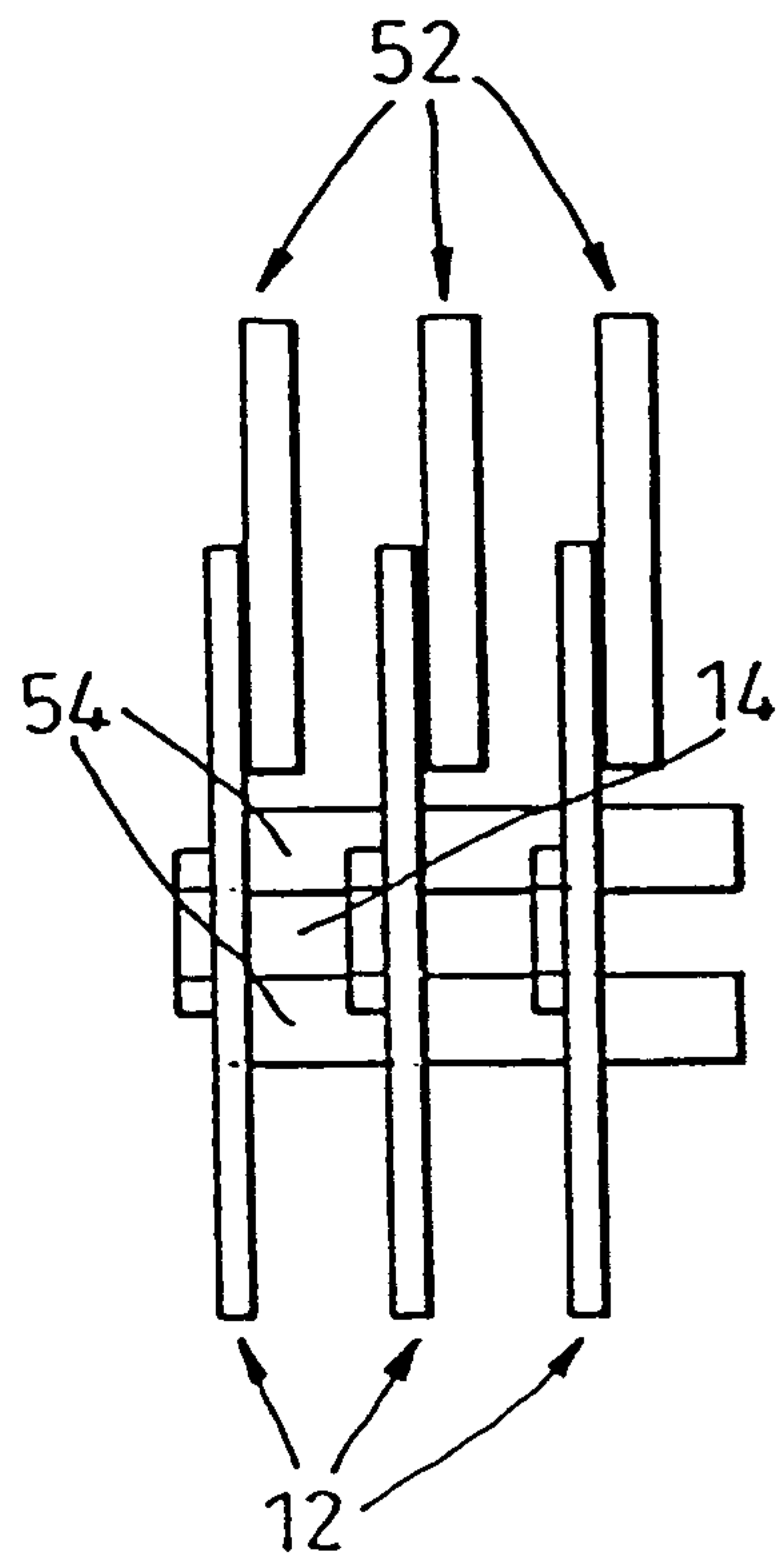

Fig. 5a

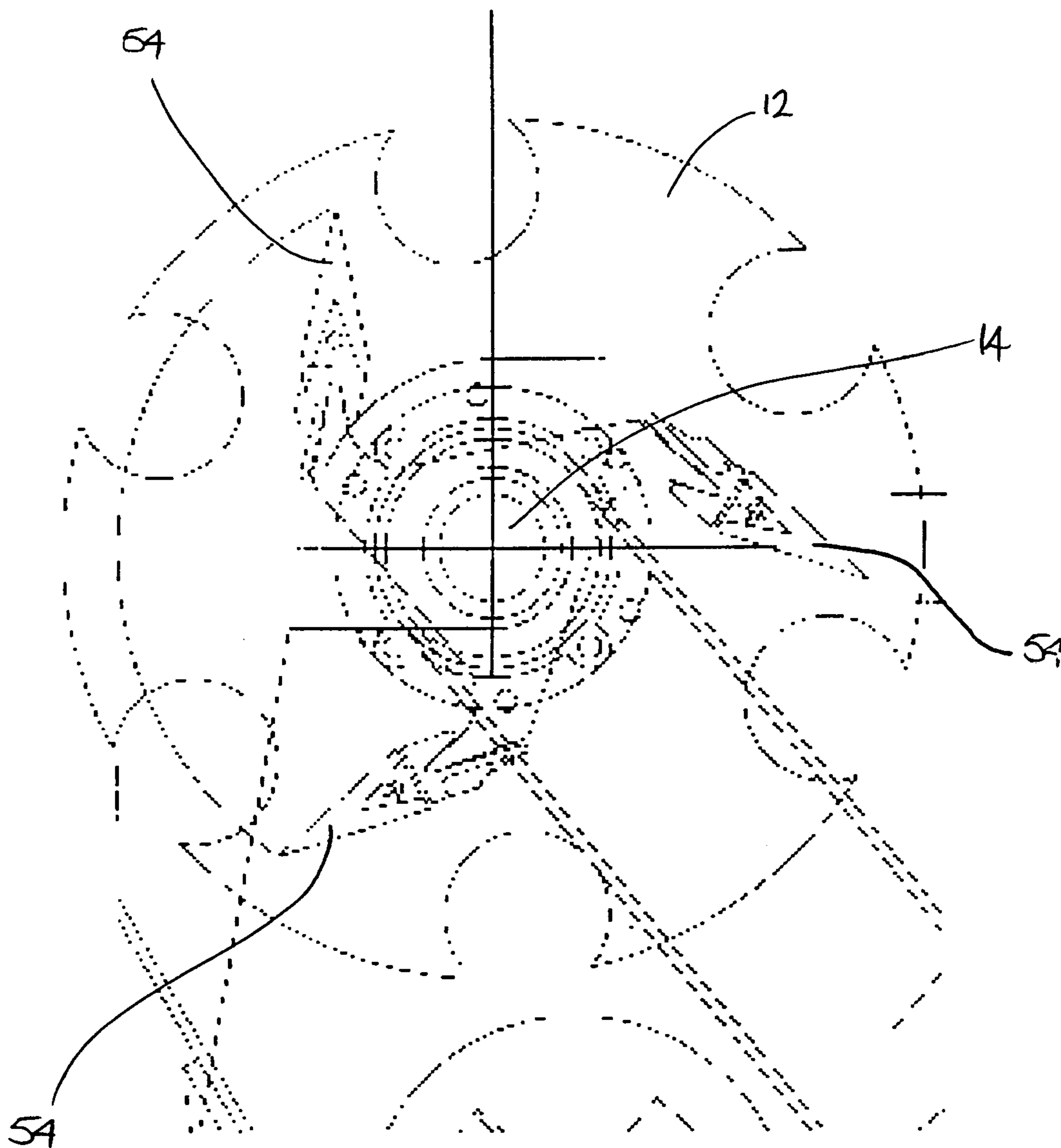

Fig. 5b

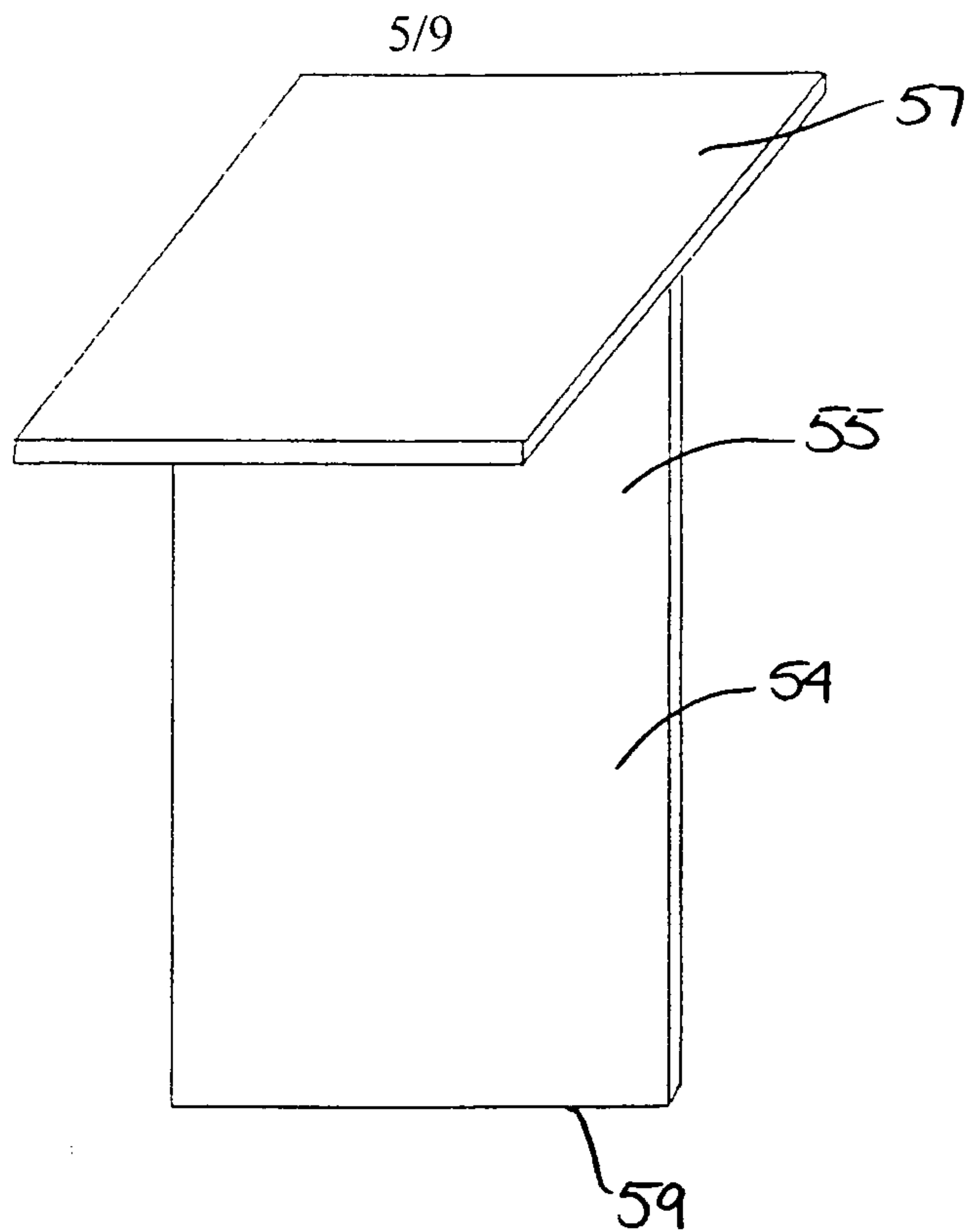

Fig. 5c

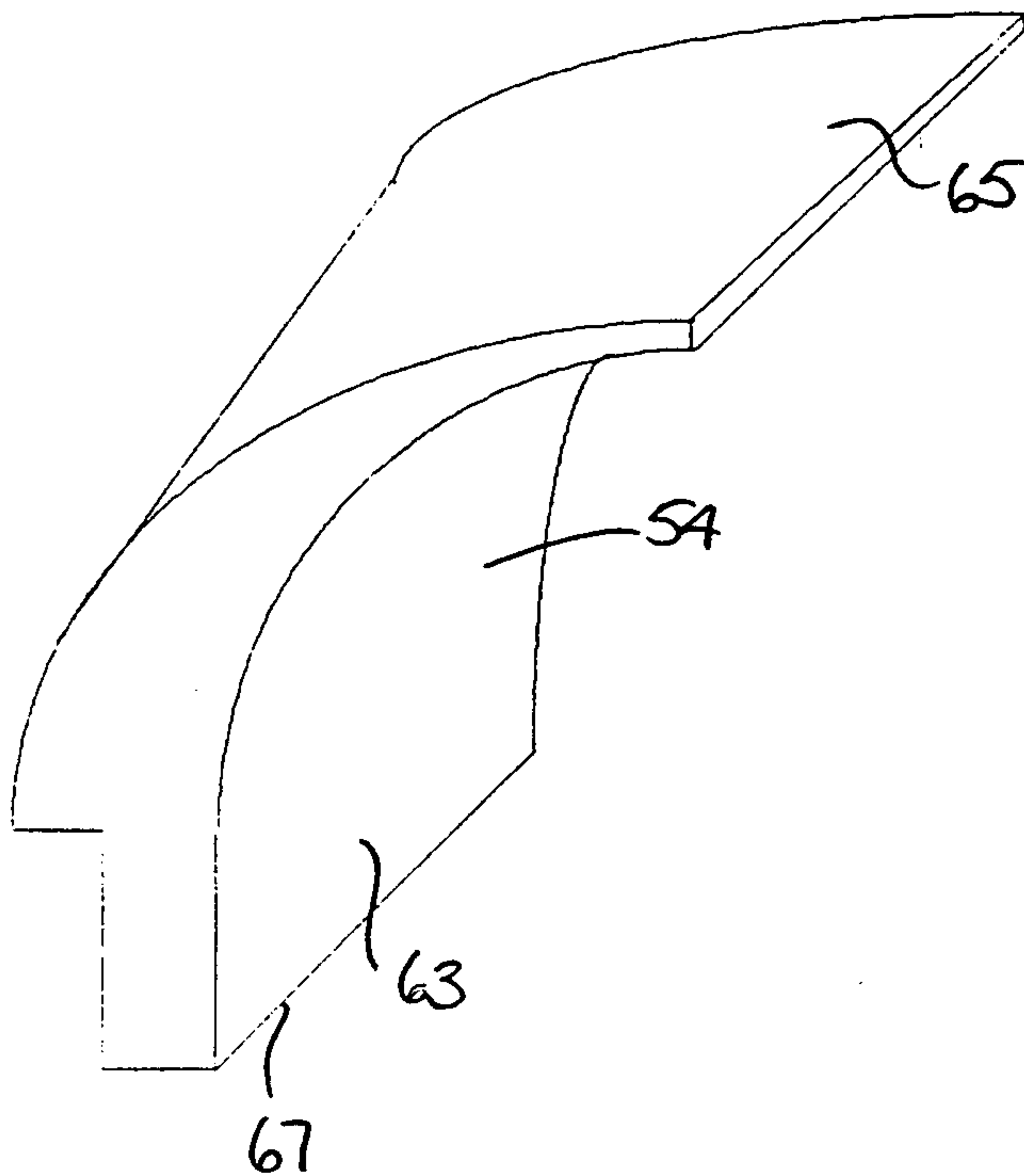

Fig. 5d

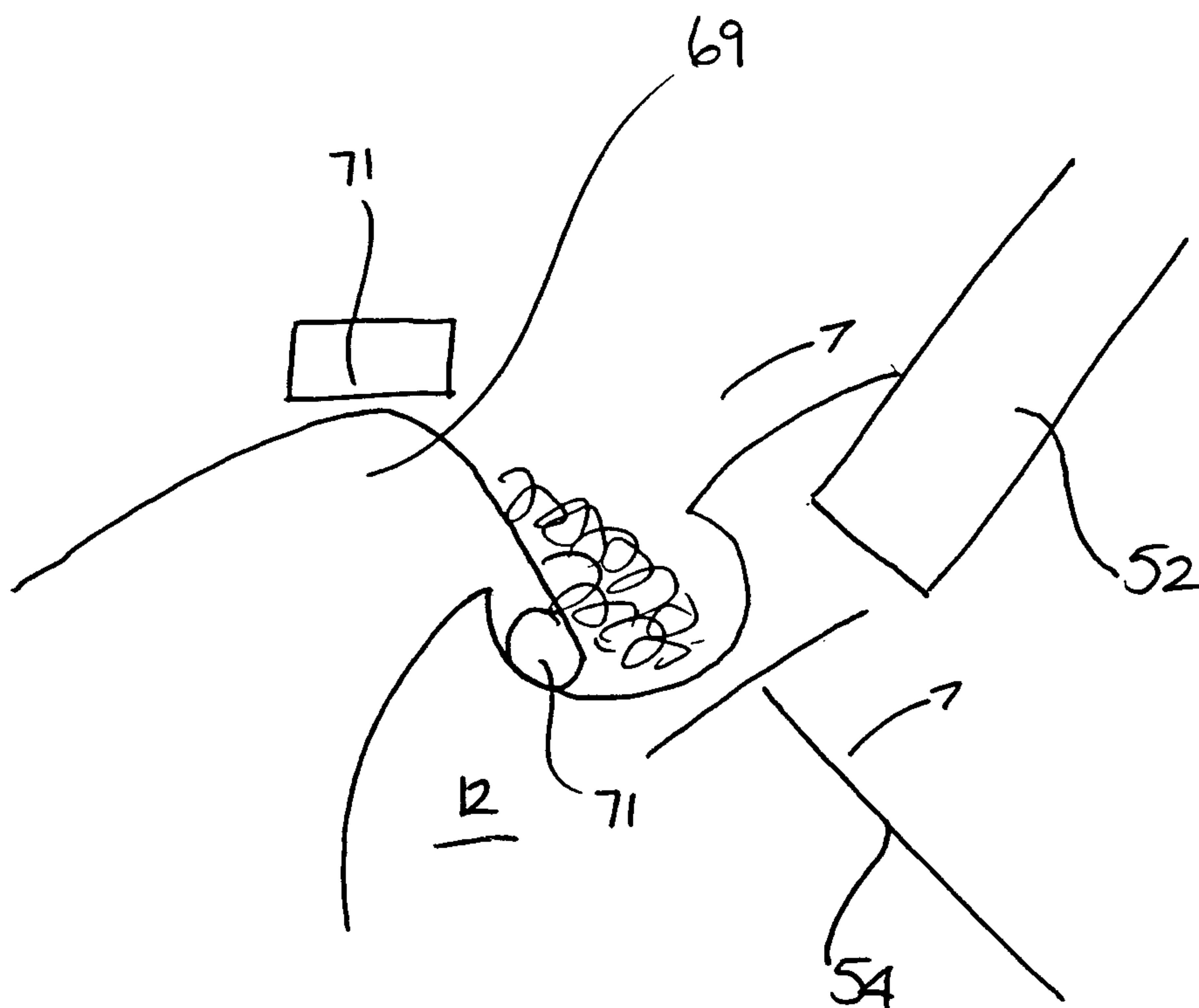

Figure 5e

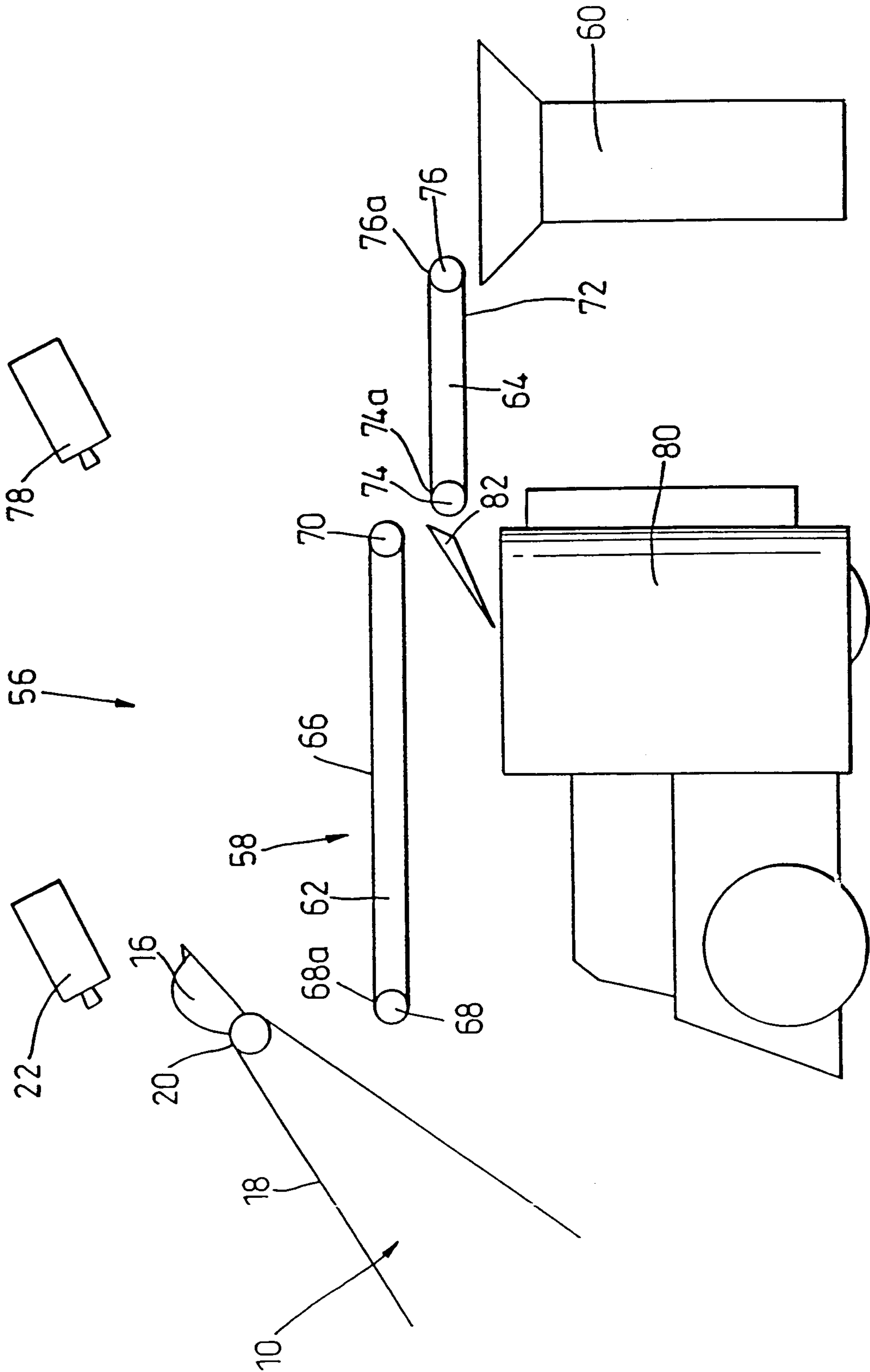

Fig. 6

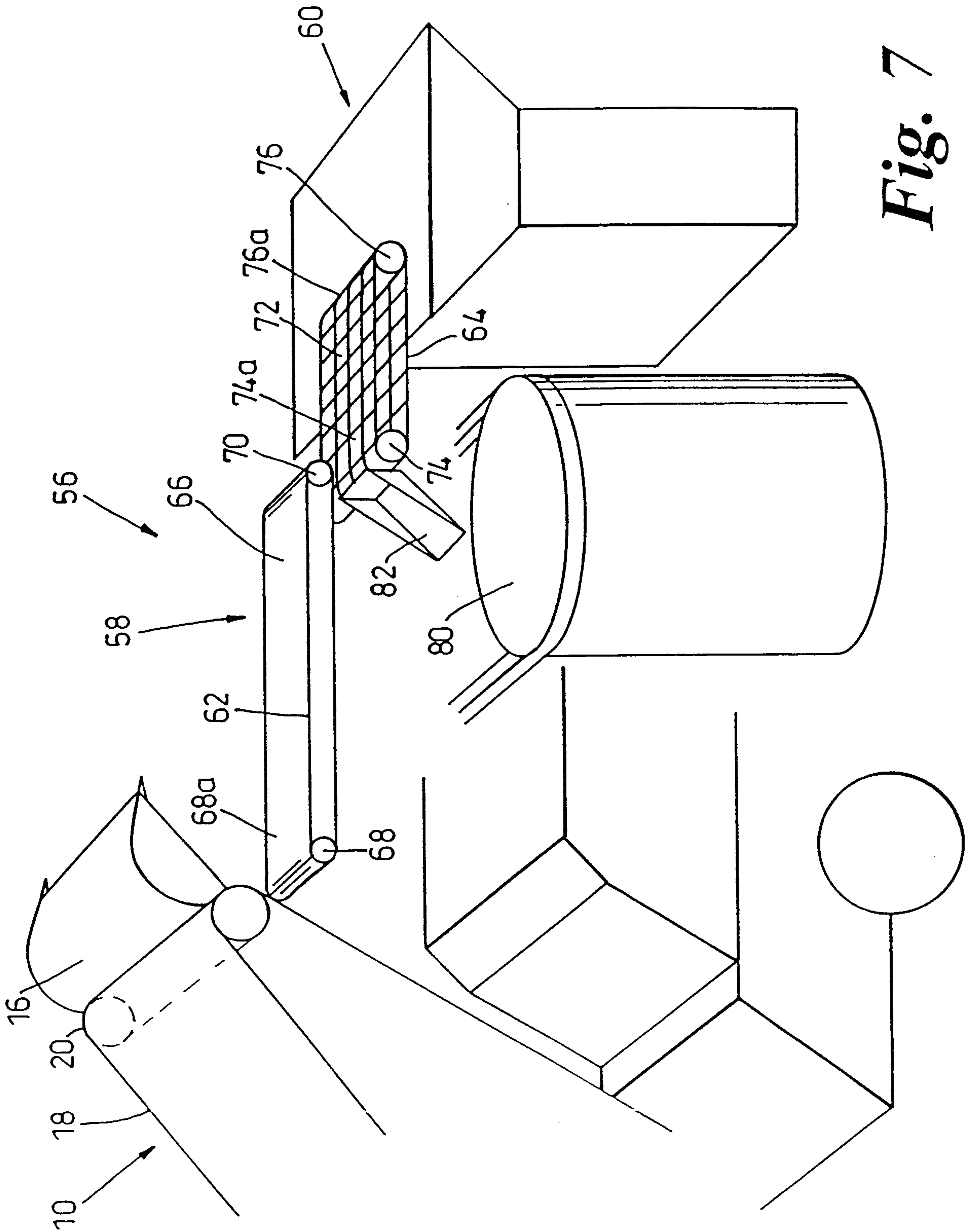

Fig. 7

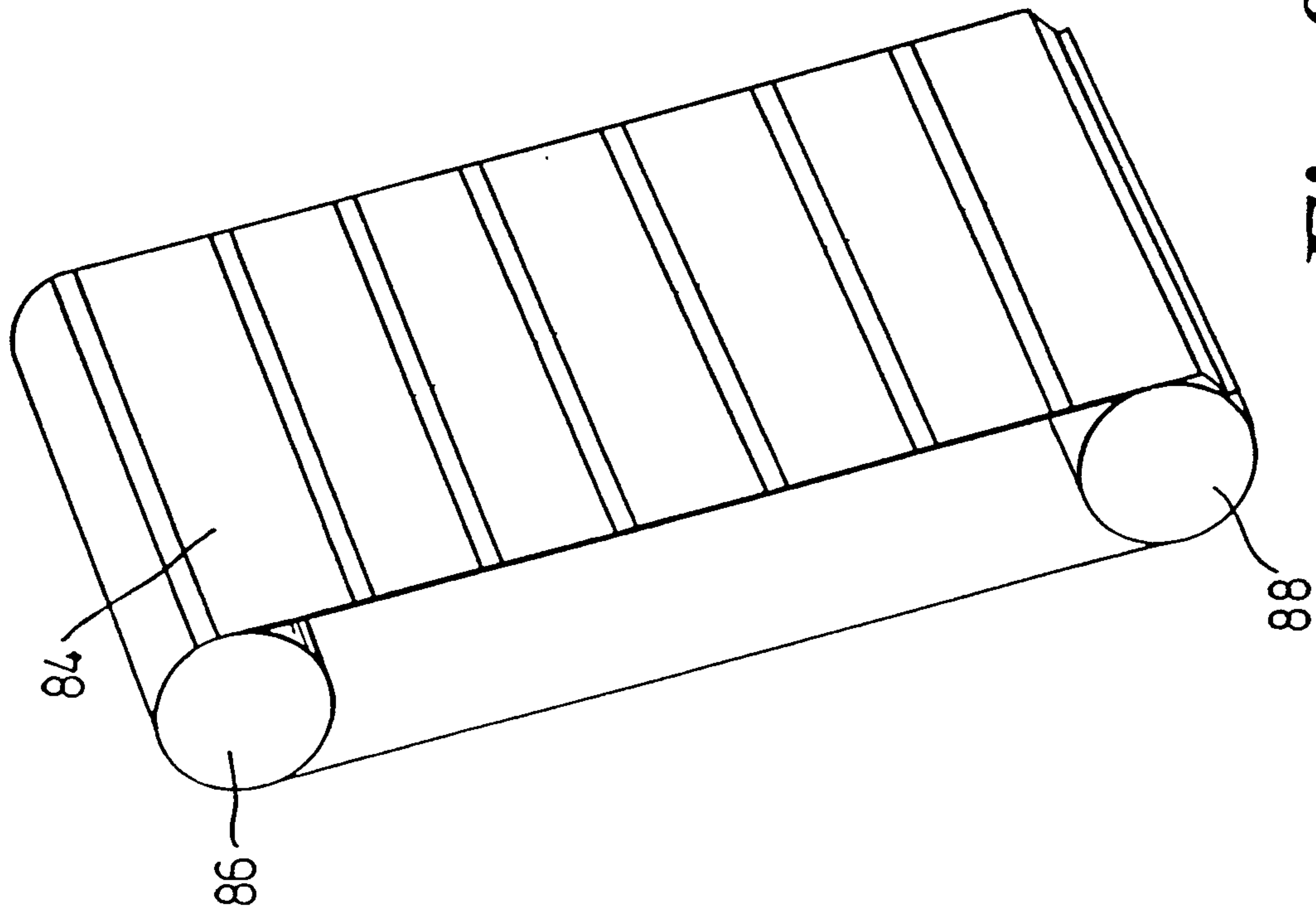

Fig. 8A

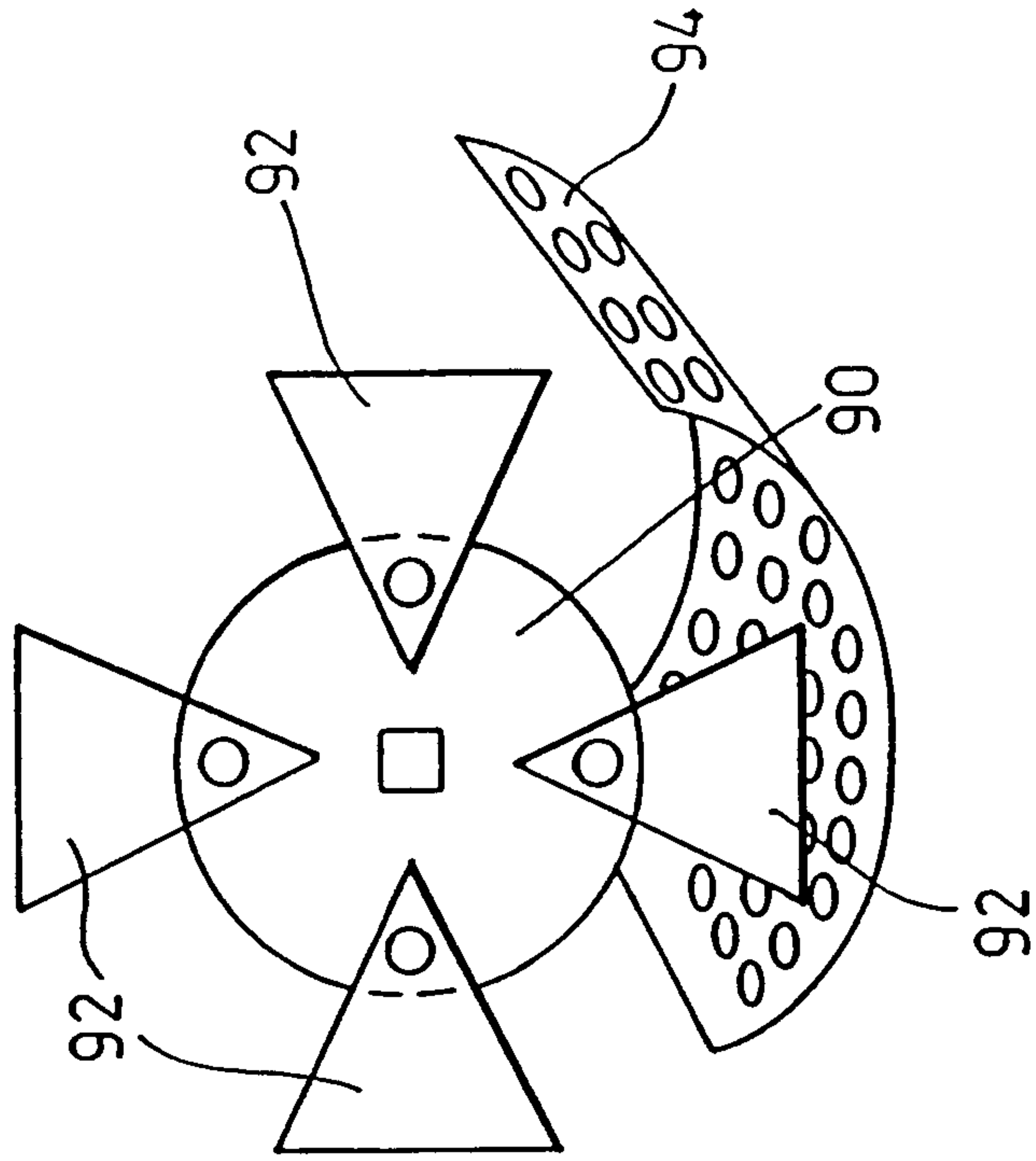

Fig. 8B

