



- (51) **International Patent Classification:**
A61M 5/158 (2006.01)
- (21) **International Application Number:**
PCT/US2015/036715
- (22) **International Filing Date:**
19 June 2015 (19.06.2015)
- (25) **Filing Language:** English
- (26) **Publication Language:** English
- (30) **Priority Data:**
62/014,766 20 June 2014 (20.06.2014) US
62/035,682 11 August 2014 (11.08.2014) US
- (71) **Applicant:** **CLEARSIDE BIOMEDICAL, INC.** [US/US]; 1220 Old Alpharetta Road, Suite 300, Alpharetta, Georgia 30005 (US).
- (72) **Inventors:** **ANDINO, Rafael Victor**; 2621 Legacy Walk Court, Grayson, Georgia 30017 (US). **BROOKS, Christopher John**; 5 Ashleigh Court, Glen Cove, New York 11542 (US). **ZARNITSYN, Vladimir**; 3128 Mercer University Drive, Atlanta, Georgia 30341 (US). **WHITE, Harrison J.**; 212 Rivergate Drive, Suwanee, Georgia 30024 (US).
- (74) **Agents:** **MILLS, John R.** et al.; Cooley LLP, 1299 Pennsylvania Avenue, NW, Suite 700, Washington, District of Columbia 20004 (US).
- (81) **Designated States** (unless otherwise indicated, for every kind of national protection available): AE, AG, AL, AM, AO, AT, AU, AZ, BA, BB, BG, BH, BN, BR, BW, BY, BZ, CA, CH, CL, CN, CO, CR, CU, CZ, DE, DK, DM, DO, DZ, EC, EE, EG, ES, FI, GB, GD, GE, GH, GM, GT, HN, HR, HU, ID, IL, IN, IR, IS, JP, KE, KG, KN, KP, KR, KZ, LA, LC, LK, LR, LS, LU, LY, MA, MD, ME, MG, MK, MN, MW, MX, MY, MZ, NA, NG, NI, NO, NZ, OM, PA, PE, PG, PH, PL, PT, QA, RO, RS, RU, RW, SA, SC, SD, SE, SG, SK, SL, SM, ST, SV, SY, TH, TJ, TM, TN, TR, TT, TZ, UA, UG, US, UZ, VC, VN, ZA, ZM, ZW.
- (84) **Designated States** (unless otherwise indicated, for every kind of regional protection available): ARIPO (BW, GH, GM, KE, LR, LS, MW, MZ, NA, RW, SD, SL, ST, SZ, TZ, UG, ZM, ZW), Eurasian (AM, AZ, BY, KG, KZ, RU, TJ, TM), European (AL, AT, BE, BG, CH, CY, CZ, DE, DK, EE, ES, FI, FR, GB, GR, HR, HU, IE, IS, IT, LT, LU, LV, MC, MK, MT, NL, NO, PL, PT, RO, RS, SE, SI, SK, SM, TR), OAPI (BF, BJ, CF, CG, CI, CM, GA, GN, GQ, GW, KM, ML, MR, NE, SN, TD, TG).

[Continued on next page]

(54) **Title:** VARIABLE DIAMETER CANNULA AND METHODS FOR CONTROLLING INSERTION DEPTH FOR MEDICAMENT DELIVERY

Fig. 5

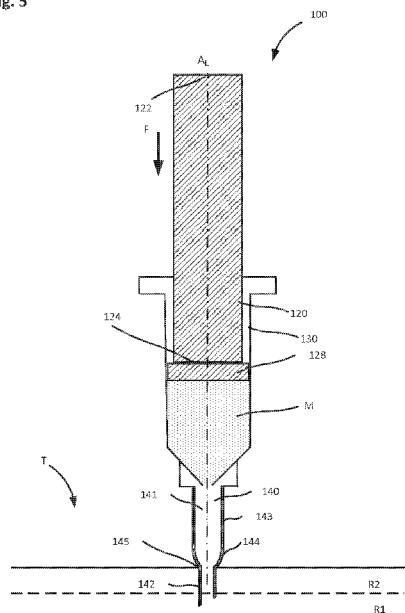

(57) **Abstract:** An apparatus includes a microneedle that defines a lumen therethrough. The microneedle has a proximal end portion, a distal end portion, and a hub portion between the proximal end portion and the distal end portion. The proximal end portion is configured to be coupled to a medication container, such as, for example a syringe. The portion of the lumen within the proximal end portion has a first diameter. The distal end portion is configured to pierce a target tissue. The portion of the lumen within the distal end portion has a second diameter smaller than the first diameter. The hub portion includes a surface configured to contact the target tissue when the distal end portion is disposed with the target tissue.

Declarations under Rule 4.17:

— *as to applicant's entitlement to apply for and be granted a patent (Rule 4.17(ii))*

Published:

— *without international search report and to be republished upon receipt of that report (Rule 48.2(g))*

VARIABLE DIAMETER CANNULA AND METHODS FOR CONTROLLING INSERTION DEPTH FOR MEDICAMENT DELIVERY

Cross-Reference to Related Applications

[1001] This application claims priority to and the benefit of U.S. Provisional Patent Application Serial No. 62/035,682 entitled, "Apparatus and Methods for Controlling the Insertion Depth of a Needle," filed August 11, 2014 and U.S. Provisional Patent Application Serial No. 62/014,766 entitled, "Variable Diameter Cannula for Medicament Delivery," filed June 20, 2014, each of which is incorporated herein by reference in its entirety.

Background

[1002] The embodiments described herein relate generally to the field of ophthalmic therapies and more particularly to the use of a microneedle for delivery and/or removal of a substance, such as a fluid therapeutic agent into and/or from ocular tissues for treatment of the eye.

[1003] Although needles are used in transdermal and intraocular drug delivery, there remains a need for improved microneedle devices and methods, particularly for delivery of substances (e.g., drugs) into the posterior region of the eye. Many inflammatory and proliferative diseases in the posterior region (or other regions) of the eye require long-term pharmacological treatment. Examples of such diseases include macular degeneration, diabetic retinopathy, and uveitis. It is often difficult to deliver effective doses of a drug to the back of the eye using conventional delivery methods such as topical application or an intravitreal administration (IVT), which has poor efficacy, and systemic administration, which often causes significant side effects. For example, while eye drops are useful in treating conditions affecting the exterior surface of the eye or tissues at the front of the eye, the eye drops are often not sufficiently conveyed to the back of the eye, as may be required for the treatment of some of the retinal diseases listed above.

[1004] Although there have been advances in the past decade regarding the utilization of systemically delivered substances, there are obstacles to wide spread adoption of such methods. For example, in certain situations, direct injection into the eye (e.g., into the vitreous) using conventional 27 gauge or 30 gauge needles and syringes can be effective. Direct injection, however, can be associated with significant safety risks, and physicians

often require professional training to effectively perform such methods. Moreover, in some instances, targeted injection of a therapeutic agent is desirable. In such instances, however, the relatively small anatomic structures of the eye often result in significant challenges to placing a needle at a target location using known devices and methods, especially as they pertain to placing the distal end of the needle at the desired depth within the eye. Furthermore, IVT administration can have side effects such as increased intraocular pressure or faster onset of cataract formation.

[1005] In addition, many known methods of direct injection of a drug into the eye include inserting a needle or a cannula at an acute angle relative to a surface of the eye, which can make controlling the depth of insertion challenging. For example, some such methods include controlling the angular orientation of the needle such that the injected substance exits the needle at a particular location. Moreover, some known methods of injecting substances into ocular tissue include using complicated visualization system or sensors to control the placement of the needle or cannula.

[1006] Known devices for ocular injection do not provide the mechanism for adjusting needle length so that the needle can be inserted into the eye to the desired depth. Known systems also do not provide a reliable mechanism for determining when the needle tip is in the desired location, for example, the suprachoroidal space (SCS) of the eye. Such shortcomings in known systems and methods are exacerbated because the size and thickness of various layers included in the eye can vary substantially from one person to another. For example, the thickness of the conjunctiva and the sclera can be substantially different and their true value cannot easily be predetermined via standard techniques. Furthermore, the thickness of these layers can also be different in different portions of the eye and at different times of the day in the same eye and location. Therefore, using known systems and methods it can be challenging to determine and/or adjust the length of the needle for puncturing the eye, such that a tip of the needle is at the desired depth, for example, the SCS. Too short a needle might not penetrate the sclera, and too long a needle can traverse beyond the SCS and damage the retina of the eye. Further, known systems do not provide a convenient way to detect the position of the needle tip within the eye.

[1007] Because of the sensitivities associated with intraocular injection (e.g., the sensitivity of the tissue, the potential impact on intraocular pressure and the like), many

known systems involve manual injection, often using needles and/or cannulas having a small diameter (e.g., 27 gauge, 30 gauge, or even smaller) and lengths of 12 mm, 15 mm or even longer. More particularly, many known devices and methods include the user manually applying a force (e.g., via pushing a plunger with their thumb or fingers) to expel a fluid (e.g., a drug) into the eye. Because of the small needle size and/or the characteristics of the injected drug, some such devices and methods involve the use of force levels higher than that which users are comfortable with applying. For example, some studies have shown that users generally do not like to apply more than 2N force against the eye during ocular injection. Accordingly, in certain situations a user may not properly deliver the medicament using known systems and methods because of their reluctance to apply the force to fully expel the medicament.

[1008] Moreover, injection into different target layers of the eye can cause variability in the amount of the force required for insertion of the needle and/or injection of the medicament. Different layers of the eye can have different densities. For example, the sclera generally has a higher density than the conjunctiva or the SCS. Differences in the density of the target region or layer can produce different backpressure against the needle exit, i.e., the tip of the needle from which the fluid emerges. Thus, injection into a relatively dense ocular material such as sclera requires more motive pressure to expel the medicament from the needle than is required when injecting a medicament into the SCS.

[1009] Furthermore, the injection force to expel the medicament also depends on the density and viscosity of the liquid medicament, length of the needle, and/or diameter of the needle. To inject certain medicaments into the eye via desired needles (e.g., 27 gauge, 30 gauge, or even smaller) can require more force than many practitioners are comfortable (or capable of) applying.

[1010] Thus, a need exists for improved devices and methods, which can assist in facilitating injection of a viscous medicament into ocular tissue.

Summary

[1011] In some embodiments, an apparatus includes a microneedle that defines a lumen therethrough. The microneedle has a proximal end portion a distal end portion and a hub portion between the proximal end portion and the distal end portion. The proximal end portion is configured to be coupled to a medicament container, such as, for example a

syringe. The portion of the lumen within the proximal end portion has a first diameter. The distal end portion is configured to pierce a target tissue. The portion of the lumen within the distal end portion has a second diameter smaller than the first diameter. The hub portion includes a surface configured to contact the target tissue when the distal end portion is disposed with the target tissue.

Brief Description of the Drawings

[1012] FIG. 1 is a cross-sectional view of an illustration of the human eye.

[1013] FIG. 2 is a cross-sectional view of a portion of the human eye of FIG. 1 taken along the line 2-2.

[1014] FIGS. 3 and 4 are cross-sectional views of a portion of the human eye of FIG. 1 taken along the line 3-3, illustrating the suprachoroidal space without and with, respectively, the presence of a fluid.

[1015] FIG. 5 is a schematic illustration of an apparatus that includes an actuation rod and a microneedle, according to an embodiment.

[1016] FIG. 6 is a cross-sectional view of a microneedle, according to an embodiment.

[1017] FIG. 7 is a perspective view of a medical injector, according to an embodiment.

[1018] FIG. 8 is an exploded view of the medical injector of FIG. 7.

[1019] FIG. 9 is an exploded view of the needle assembly of FIG. 7.

[1020] FIG. 10 is a cross-sectional view of the needle assembly of FIG. 9, taken along line 10-10.

[1021] FIG. 11A is an exploded view of a needle assembly, according to an embodiment.

[1022] FIG. 11B is a side view of the needle assembly of FIG. 11A, in an assembled configuration.

[1023] FIG. 11C is a cross-sectional view of the needle assembly of FIG. 11A, in an assembled configuration.

[1024] FIG. 12 is a schematic illustration of an apparatus that includes a medical injector, a compressible member and a hub, according to an embodiment.

[1025] FIG. 13 is a side cross-sectional view of the apparatus of FIG. 12 in a first configuration.

[1026] FIG. 14 is a side cross-sectional view of the apparatus of FIG. 12 in a second configuration.

[1027] FIG. 15 is a side cross-sectional view of the apparatus of FIG. 12 in a third configuration.

[1028] FIG. 16 is a side cross-sectional view of a portion of an apparatus that includes a medical injector, a compressible member, a hub, and a stopping mechanism in a first configuration, according to an embodiment.

[1029] FIG. 17 is a side cross-sectional view of the apparatus of FIG. 16 in a second configuration.

Detailed Description

[1030] The embodiments described herein relate to systems and devices for delivering a fluid (e.g., a drug) into or extracting a fluid from the sclera of an eye. Furthermore, embodiments described herein are related to microneedles and/or delivery cannulas configured to convey a viscous medicament into ocular tissue. Embodiments described herein are also related to systems, devices, and methods for controlling the insertion depth of a delivery member, such as, for example, a microneedle, into the eye to deliver a therapeutic agent to, for example, a posterior region of the eye (e.g., via the suprachoroidal space). Embodiments, described herein are also related to microneedles and/or delivery cannulas configured to form a substantially fluid-tight seal around a delivery passageway formed by insertion of a delivery member, for example, a microneedle, into the eye to prevent leakage of the substance and/or ocular fluid from the insertion site.

[1031] In some embodiments, the microneedles included in the embodiments described herein include a bevel at the distal tip, which allows for ease of penetration into the sclera and/or suprachoroidal space with minimal collateral damage. Moreover, in some embodiments, the microneedles disclosed herein can define a narrow lumen (e.g., gauge size greater than or equal to 30 gauge, 32 gauge, 34 gauge, 36 gauge, etc.) to allow for suprachoroidal drug delivery while minimizing the diameter of the needle track caused by the insertion of the microneedle. In some embodiments, the lumen and bevel aspect ratio of the microneedles described herein are distinct from standard 27 gauge and 30 gauge needles, which are now commonly used for intraocular injection. For example, the microneedles included in the embodiments described herein can be any of those described in International Patent Application Publication No. WO2014/036009, entitled, "Apparatus and Methods for Drug Delivery Using Microneedles," filed on August 27, 2013, the disclosure of which is incorporated by reference herein in its entirety (referred to henceforth as the "'009 PCT application").

[1032] In some embodiments, an apparatus includes a microneedle that defines a lumen therethrough. The microneedle has a proximal end portion a distal end portion and a hub portion between the proximal end portion and the distal end portion. The proximal end portion is configured to be coupled to a medicament container, such as, for example a syringe. The portion of the lumen within the proximal end portion has a first diameter. The distal end portion is configured to pierce a target tissue. The portion of the lumen within the distal end portion has a second diameter smaller than the first diameter. The hub portion includes a surface configured to contact the target tissue when the distal end portion is disposed with the target tissue.

[1033] In some embodiments, an apparatus includes a microneedle that defines a lumen therethrough. The microneedle has a proximal end portion a distal end portion and a hub portion between the proximal end portion and the distal end portion. The portion of the lumen within the hub portion is characterized by a diameter that changes along a longitudinal axis of the lumen. Similarly stated, the diameter of the lumen varies within the hub portion from a first diameter at the proximal end portion to a second, smaller diameter at the distal end portion. The hub portion of the microneedle has a convex distal end surface, which is configured to contact a target surface of a target tissue when a substance is conveyed through the needle into the target tissue. In some embodiments, the distal end surface includes a

sealing portion configured to define a substantially fluid-tight seal with the target surface when the distal end surface is in contact with the target surface.

[1034] In some embodiments, a method includes inserting a distal end portion of a needle of a medical injector into a target tissue to define a delivery passageway within the target tissue. This is followed by placing a convex hub surface of the needle into contact with a target surface of the target tissue to fluidically isolate the delivery passageway. Next, the method includes conveying, after the placing, a substance into the target tissue via the needle. The conveying includes conveying the substance through a proximal end portion of the needle having a first diameter and the distal end portion of the needle having a second diameter. In some embodiments, the target tissue is an eye and the target surface is the conjunctiva of the eye. In some embodiments, the delivery passageway extends through a sclera of the eye and the conveying includes conveying the substance into at least one of a suprachoroidal space or lower portion of the sclera. In such embodiments, the method can further include adjusting, before the conveying, a length of the needle extending from the distal end surface of the hub.

[1035] In some embodiments, a method includes inserting a distal end portion of a needle of a medical injector into a target tissue to define a delivery passageway within the target tissue. The inserting is performed such that a centerline of the needle is substantially normal to a target surface of the target tissue. This is followed by placing a distal end surface of a hub of the needle into contact with a target surface of the target tissue to fluidically isolate the delivery passageway. Next, the method includes conveying, after the placing, a substance into the target tissue via the needle. In some embodiments, the delivery is performed such that a centerline of the delivery passageway and a surface line tangent to the target surface defines an angle of entry of between about 75 degrees and about 105 degrees.

[1036] In some embodiments, an apparatus includes a hub and a puncture member. The hub is configured to be coupled to a medicament container. A distal end surface of the hub is configured to contact a target surface of a target tissue. The puncture member is coupled within the passageway of the hub. When the hub is coupled to the medicament container, the puncture member defines a lumen therethrough in fluid communication with the medicament container. A distal end portion of the puncture member extends distally from the distal end surface of the hub. A proximal end portion of the puncture member defines a first inner diameter and the distal end portion of the puncture member defines a second inner diameter. The second inner diameter is smaller than the first inner diameter.

[1037] In some embodiments, an apparatus includes a medicament container, a hub, and a microneedle. The medicament container contains a medicament having a viscosity of at least about 100 centiPoise. An actuation rod is disposed in the medicament container. The hub is configured to be coupled to the medicament container. The hub defines a passageway. A distal end surface of the hub is configured to contact a target surface of a target tissue. The microneedle is coupled within the passageway of the hub. When the hub is coupled to the medicament container, the microneedle defines a lumen in fluid communication with the medicament container. A distal end portion of the microneedle extends distally from the distal end surface of the hub. The distal end portion of the microneedle defines an inner diameter being 30 gauge or smaller. A length of the distal end portion of the microneedle being such that the medicament is conveyed through the lumen when a force of less than about 6 N is exerted on the actuation rod. In some embodiments, the length is such that the medicament is conveyed through the lumen at a flow rate of between about 0.1 $\mu\text{L}/\text{sec}$ and about 10 $\mu\text{L}/\text{sec}$ when a force of less than about 6 N is exerted on the actuation rod. In some embodiments, the length is such that the medicament is conveyed through the lumen at a flow rate of at least about 1.0 $\mu\text{L}/\text{sec}$.

[1038] In some embodiments, an apparatus includes a medicament container, a hub, and a needle. The medicament container contains a medicament, and includes an elastomeric member disposed therein such that movement of the elastomeric member conveys the medicament within the medicament container. The hub is configured to be coupled to the medicament container. The needle is configured to be coupled to the medicament container via the hub. The needle defines a lumen in fluid communication with the medicament container. A distal end portion of the needle defines an inner diameter being 30 gauge or smaller, and has a length of between about 200 microns and about 1500 microns. A proximal end portion of the needle defines an inner diameter being 27 gauge or bigger. The needle includes a transition portion between the proximal end portion and the distal end portion. An outer surface of the transition portion configured to contact a target surface of a target tissue during an injection event.

[1039] In some embodiments, an apparatus includes a medicament container assembly, a needle, a hub, and a compressible member. The needle is in fluid communication with the medicament container assembly. The hub is configured to be operatively coupled to a distal end portion of the medicament container assembly. The hub defines a first passageway. A

distal end surface of the hub is configured to contact a target surface of a target tissue. The compressible member is disposed between the hub and the distal end portion of the medicament container assembly. The compressible member defines a second passageway, and the first passageway and the second passageway are aligned to receive at least a portion of the needle therethrough. The compressible member is configured to be compressed in response to a force exerted on the medicament container assembly such that a thickness of the compressible member reduces from a first thickness to a second thickness.

[1040] As used herein, the singular forms “a,” “an”, and “the” include plural referents unless the context clearly dictates otherwise. Thus, for example, the term “a member” is intended to mean a single member or a combination of members, “a material” is intended to mean one or more materials, or a combination thereof.

[1041] As used herein, the words “proximal” and “distal” refer to the direction closer to and away from, respectively, an operator (e.g., surgeon, physician, nurse, technician, etc.) who would insert the medical device into the patient, with the tip-end (i.e., distal end) of the device inserted inside a patient’s body first. Thus, for example, the end of a microneedle described herein first inserted inside the patient’s body would be the distal end, while the opposite end of the microneedle (e.g., the end of the medical device being manipulated by the operator) would be the proximal end of the microneedle.

[1042] As used herein, a “set” can refer to multiple features or a singular feature with multiple parts. For example, when referring to set of walls, the set of walls can be considered as one wall with distinct portions, or the set of walls can be considered as multiple walls.

[1043] As used herein, the terms “about” and “approximately” generally mean plus or minus 10% of the value stated. For example, about 0.5 would include 0.45 and 0.55, about 10 would include 9 to 11, about 1000 would include 900 to 1100.

[1044] As used herein, the terms “delivery member”, “puncture member”, and “puncturing member” are used interchangeably to refer to an article configured to pierce tissue layers and deliver a substance to a target tissue layer, for example, a needle or a microneedle.

[1045] As used herein, the terms “medicament container”, and “medicament containment chamber” are used interchangeably to refer to an article configured to contain a volume of a substance, for example, a medicament.

[1046] The term “fluid-tight” is understood to encompass both a hermetic seal (i.e., a seal that is gas-impervious) as well as a seal that is liquid-impervious. The term “substantially” when used in connection with “fluid-tight,” “gas-impervious,” and/or “liquid-impervious” is intended to convey that, while total fluid imperviousness is desirable, some minimal leakage due to manufacturing tolerances, or other practical considerations (such as, for example, the pressure applied to the seal and/or within the fluid), can occur even in a “substantially fluid-tight” seal. Thus, a “substantially fluid-tight” seal includes a seal that prevents the passage of a fluid (including gases, liquids and/or slurries) therethrough when the seal is maintained at a constant position and at fluid pressures of less than about 5 psig, less than about 10 psig, less than about 20 psig, less than about 30 psig, less than about 50 psig, less than about 75 psig, less than about 100 psig and all values in between. Similarly, a “substantially liquid-tight” seal includes a seal that prevents the passage of a liquid (e.g., a liquid medicament) therethrough when the seal is maintained at a constant position and is exposed to liquid pressures of less than about 5 psig, less than about 10 psig, less than about 20 psig, less than about 30 psig, less than about 50 psig, less than about 75 psig, less than about 100 psig and all values in between.

[1047] The embodiments and methods described herein can be used to treat, deliver substances to and/or aspirate substances from, various target tissues in the eye. For reference, FIGS. 1-4 are a various views of a human eye 10 (with FIGS. 2-4 being cross-sectional views). While specific regions are identified, those skilled in the art will recognize that the proceeding identified regions do not constitute the entirety of the eye 10, rather the identified regions are presented as a simplified example suitable for the discussion of the embodiments herein. The eye 10 includes both an anterior segment 12 (the portion of the eye in front of and including the lens) and a posterior segment 14 (the portion of the eye behind the lens). The anterior segment 12 is bounded by the cornea 16 and the lens 18, while the posterior segment 14 is bounded by the sclera 20 and the lens 18. The anterior segment 12 is further subdivided into the anterior chamber 22, between the iris 24 and the cornea 16, and the posterior chamber 26, between the lens 18 and the iris 24. The cornea 16 and the sclera 20 collectively form a limbus 38 at the point at which they meet. The exposed portion of the sclera 20 on the anterior segment 12 of the eye is protected by a clear membrane referred to as the conjunctiva 45 (see e.g., FIGS. 2 and 3). Underlying the sclera 20 is the choroid 28 and the retina 27, collectively referred to as retinachoroidal tissue. A vitreous humour 30 (also referred to as the “vitreous”) is disposed between a ciliary body 32 (including a ciliary

muscle and a ciliary process) and the retina 27. The anterior portion of the retina 27 forms an ora serrata 34. The loose connective tissue, or potential space, between the choroid 28 and the sclera 20 is referred to as the suprachoroid. FIG. 2 illustrates the cornea 16, which is composed of the epithelium 40, the Bowman's layer 41, the stroma 42, the Descemet's membrane 43, and the endothelium 44. FIG. 3 illustrates the sclera 20 with surrounding Tenon's Capsule 46 or conjunctiva 45, suprachoroidal space 36, choroid 28, and retina 27, substantially without fluid and/or tissue separation in the suprachoroidal space 36 (i.e., in this configuration, the space is "potential" suprachoroidal space). As shown in FIG. 3, the sclera 20 has a thickness between about 500 μm and 700 μm . FIG. 4 illustrates the sclera 20 with the surrounding Tenon's Capsule 46 or the conjunctiva 45, suprachoroidal space 36, choroid 28, and retina 27, with fluid 50 in the suprachoroidal space 36.

[1048] As used herein, the term "suprachoroidal space," or SCS which is synonymous with suprachoroid, or suprachoroidia, describes the space (or volume) and/or potential space (or potential volume) in the region of the eye 10 disposed between the sclera 20 and choroid 28. This region primarily is composed of closely packed layers of long pigmented processes derived from each of the two adjacent tissues; however, a space can develop in this region because of fluid or other material buildup in the suprachoroidal space and the adjacent tissues. The suprachoroidal space can be expanded by fluid buildup because of some disease state in the eye or because of some trauma or surgical intervention. In some embodiments, the fluid buildup is intentionally created by the delivery, injection and/or infusion of a drug formulation into the suprachoroid to create and/or expand further the suprachoroidal space 36 (i.e., by disposing a drug formulation therein). This volume may serve as a pathway for uveoscleral outflow (i.e., a natural process of the eye moving fluid from one region of the eye to the other through) and may become a space in instances of choroidal detachment from the sclera.

[1049] The dashed line in FIG. 1 represents the equator of the eye 10. In some embodiments, the insertion site of any of the microneedles and/or methods described herein is between the equator and the limbus 38 (i.e., in the anterior portion 12 of the eye 10). For example, in some embodiments, the insertion site is between about two millimeters and 10 millimeters (mm) posterior to the limbus 38. In other embodiments, the insertion site of the microneedle is at about the equator of the eye 10. In still other embodiments, the insertion site is posterior the equator of the eye 10. In this manner, a drug formulation can be

introduced (e.g., via the microneedle) into the suprachoroidal space 36 at the site of the insertion and can flow through the suprachoroidal space 36 away from the site of insertion during an infusion event (e.g., during injection).

[1050] In some embodiments, a system for ocular injection can include a medicament container and a cannula (also referred to as a microneedle) that facilitates delivery of a substance disposed in a medicament container to a target tissue, for example, the SCS. For example, FIG. 5 shows a system 100, according to an embodiment. The system 100 includes an actuation rod 120, a plug 128 (or elastomeric member), a medicament container 130, and a microneedle 140. The system 100 can be configured to deliver a medicament to region and/or a layer of a target location, for example, an eye of a patient, (e.g., to the SCS of the eye), as described herein.

[1051] The actuation rod 120 includes a proximal end portion 122 and a distal end portion 124. The proximal end portion 122 is configured to receive a force F (e.g., a force manually applied by a user) to facilitate injection of a medicament M , as described herein. In some embodiments, the system 100 can include an injection assist assembly (not shown in FIG. 5) operatively connected to actuation rod 120 that is configured to assist in the production of the force F . In such embodiments, the injection assist assembly can produce at least a portion of the force F to move the actuation rod 120 within the medicament container 130. In some embodiments, the injection assist assembly can include an energy storage member, such as a helical spring, compression, extension, spring washers, Belleville washer, tapered, any other type of spring. In other embodiments, an injection assist assembly could include a compressed gas container, or a container containing a propellant. The injection assist assembly can be any of those described in U.S. Patent Application No. 14/268,687, entitled, "Apparatus and Methods for Ocular Injection," filed on May 2, 2014, the disclosure of which is incorporated by reference herein in its entirety.

[1052] A distal end portion 124 of the actuation rod 120 is disposed within the medicament container 130. The distal end portion 124 can be coupled to and/or in contact with a plug 128 (also referred to as a plunger, stopper or elastomeric member), which is in fluidic communication with a substance M (e.g., a medicament such as, for example, VEGF, a VEGF inhibitor, a combination thereof, or any other medicament described herein) disposed within an internal volume defined by the medicament container 130. The distal end portion 124 of the actuation rod 120 is configured to be displaced within the internal volume defined

by the medicament container 130, for example, due to the force F produced by an operator's thumb (or an injection assist mechanism), as described herein. In this manner, the actuation rod 120 can displace the plug 128 within the medicament container 130 to draw in or expel the substance M from the distal end portion 142 of the microneedle 140, as described herein. The sidewalls of the plug 128 can be configured to contact the sidewalls of the medicament container 130 such that the plug 128 forms a substantially fluid-tight seal with the side wall of the medicament container 130, for example, to prevent leakage of the substance M . The plug 128 can be made of an inert and/or biocompatible material which is rigid but soft. Example materials include rubber, silicone, plastic, polymers, any other suitable material or combination thereof. In some embodiments, the plug 128 can be monolithically formed with the actuation rod 120.

[1053] The microneedle 140 includes a proximal end portion 143, a distal end portion 142 and a hub portion 144, and defines a lumen 141 therethrough. The proximal end portion 143 can be coupled to the medicament container 130 to place the lumen in fluid communication with the medicament container 130. The proximal end portion 143 can include any suitable coupling features, for example, Luer connectors, threads, snap-fit, latch, lock, friction fit, or any other suitable coupling features.

[1054] The distal end portion 142 of the microneedle 140 can define a sharp tip and/or bevel such that the needle 140 is configured to pierce a target location T , for example, a bodily tissue (e.g., ocular tissue). In this manner, the distal end portion 142 can be disposed within a first region $R1$ and/or a second region $R2$ of the target location T , as described herein. The bevel, which allows for ease of penetration into the sclera and/or suprachoroidal space with minimal collateral damage. In some embodiments, the lumen and bevel aspect ratio of the microneedles described herein are distinct from standard 27 gauge and 30 gauge needles. For example, the microneedles included in the embodiments described herein can be any of those described in International Patent Application Publication No. WO2014/036009, entitled, "Apparatus and Methods for Drug Delivery Using Microneedles," filed on August 27, 2013, the disclosure of which is incorporated by reference herein in its entirety (referred to henceforth as the "'009 PCT application").

[1055] The hub portion 144 of the microneedle 140 is disposed between the proximal end portion 143 of the needle 140 and distal end portion 142 of the needle 140. The hub portion 144 serves as a transition area between the proximal end portion 143 of the needle and the

distal end portion 142 of the needle. The hub portion 144 can be substantially arched in shape as shown in FIG. 5, and includes a contact surface 145. The contact surface 145 of the hub portion 144 is configured to make contact with the eye. In this manner the contact surface 145 can control the depth of penetration of the distal end portion 142 and/or can form a fluidic seal with the surface of the eye, as described herein.

[1056] The microneedle 140 defines a lumen 141, which is in fluidic communication with the substance M disposed within the internal volume defined by the medicament container 130. In this manner, the microneedle 140 is configured to establish fluid communication between the medicament container 130 and the target location T, for example, the first region R1 and/or the second region R2 of the target location T. In some embodiments, the target location T can be an eye such that the first region R1 is a suprachoroidal space of the eye, and the second region R2 is a sclera of the eye. The lumen 141 of the microneedle 140 can be of any suitable size or diameter. More particularly, the portion of the lumen within the proximal end portion 143 is characterized by a first diameter and the portion of the lumen within the distal end portion 142 is characterized by a second diameter that is smaller than the first diameter. Similarly stated, the microneedle 140 has a spatially varying inner diameter. In this manner, the length of the smaller diameter portion (i.e., the distal end portion 142) can be minimized to reduce the frictional losses associated with conveying the medicament through the microneedle 140. Reducing the frictional losses will, in turn, reduce the force F and/or the internal pressure that is applied by the actuation rod 120 to convey the medicament M. In certain circumstances, the pressure of the medicament M within the medicament container 130 can be modeled by the Hagen-Poiseuille law, as indicated below:

$$(1) \quad P = (8 * \mu * L * Q) / (\pi * R^4)$$

[1057] where P is the pressure of the medicament M within the medicament container 130, μ is the viscosity of the medicament M, L is the length of the needle 140, Q is the flow rate of the medicament M through the needle 140, and R is the radius of the lumen defined by the needle 140. Because the pressure (and/or force) required to inject a high viscosity fluid through a small-bore needle is proportional to the inverse of the radius of the lumen of the needle to the fourth power, the pressure of the medicament M within the medicament container 130 necessary to achieve the desired flow rate can, at times, be relatively high. By reducing the length of the small-diameter portion of the microneedle 140, the force requirement to produce a desired injection can be minimized. For example, if the second

diameter is 30 gauge or smaller, a length of the distal end portion 142 can be such that the medicament is conveyed through the lumen 141 when a force F of less than about 6 N is exerted on the actuation rod 122 (or the elastomeric member). In some embodiments, the length is such that the medicament is conveyed through the lumen at a flow rate of between about 0.1 $\mu\text{L}/\text{sec}$ and about 10 $\mu\text{L}/\text{sec}$ when a force of less than about 6 N is exerted on the actuation rod. In some embodiments, the length is such that the medicament is conveyed through the lumen at a flow rate of at least about 1.0 $\mu\text{L}/\text{sec}$.

[1058] In use, an operator (e.g., a doctor, technician, nurse, physician, ophthalmologist, etc.) can manipulate the system 100 to insert the microneedle 140 into, for example, an ocular tissue. In this manner, the distal end portion 142 of the microneedle 140 can be advanced within the target tissue to pierce the sclera and place the contact surface 145 of the hub portion 144 in contact with an outer surface of the sclera (e.g., the sclera 20 of the eye 10 in FIG. 1). The distal tip of the microneedle 140 can be moved further proximally relative to the ocular tissue to place the lumen 141 of the microneedle 140 in fluid communication with the suprachoroidal space (e.g., the suprachoroidal space 36 of the eye 10 in FIG. 1, or region R1 in FIG. 5). With the lumen 141 of the microneedle 140 in fluid communication with the suprachoroidal space, the actuation rod 120 can be moved relative to the medicament container 130 from its first position to its second position. With the distal end portion 124 of the actuation rod 120 forming a substantially fluidic seal (i.e., a substantially hermetic seal) with an inner surface of the medicament container 130, the movement of the actuation rod 120 to its second position expels the drug formulation (contained within the inner volume of the medicament container 130) through the lumen 141 of the microneedle 140. Thus, the medical injector 100 can deliver the drug formulation M to the SCS of the eye and the drug formulation can flow within the suprachoroidal space to be delivered to, for example, the posterior region of the eye.

[1059] The medicament container 130 is configured to contain a medicament M having a high viscosity (i.e., a medicament having a viscosity of at least 100 centiPoise). The medicament M can be any medicament suitable for being injected into a body, such as any of the medicaments or other therapeutic formulations (including biologics, cells or the like) as described herein. For example, in some embodiments, the medicament M can be a high viscosity substance for treatment of the eye (e.g., gel-like substance, a paste-like substance, an emulsion including both a liquid component and a solid component, or the like.) In some

embodiments, the medicament M can have a viscosity of at least about 1000 centiPoise. In some embodiments, the medicament M can have a viscosity of at least about 10,000 centiPoise. In other embodiments, the medicament M can have a viscosity of at least 100,000 centiPoise (cps). In other embodiments, the medicament M can have a viscosity of between about 40,000 cps and about 60,000 cps. As described above, the amount of kinetic energy required to move the actuation rod 120 within the medicament container 130 is dependent on, among other things, the viscosity of the medicament M, the desired flow rate of the medicament M through the distal end portion 142 of the microneedle 140, the length of the microneedle 140 and/or the size of the lumen 141 defined by the needle 140. One advantage of the present invention is its ability to reduce the length of the distal portion 142 of the microneedle 140 which in turn, greatly reduces friction losses. In doing so the operator of system 100 can administer the medicament M through a limited amount of force F.

[1060] FIG. 6 is a cross-sectional view of a microneedle 240 according to an embodiment. The microneedle 240 includes a proximal end portion 243, a distal end portion 242, a hub portion 244 and defines a lumen 241 therethrough. Although shown as being a blunt end, the distal end portion 242 of the microneedle 240 can define a sharp tip and/or bevel such that the needle 240 can pierce a target location. The hub portion 244 of the microneedle 240 is disposed between the proximal end portion 243 of the needle 240 and the distal end portion 242 of the needle 240. The hub portion 244 serves as a transition area between the proximal end portion 243 of the needle and the distal end portion 242 of the needle. The hub portion 244 can be similar to a conical shape as shown in FIG. 6 and includes a contact surface 245. The contact surface of the hub portion 245 is configured to make contact with the eye. In this manner the contact surface 245 can control the depth of penetration of the distal end portion 242 and/or can form a fluidic seal with the surface of the eye.

[1061] The microneedle 240 defines a lumen 241. The lumen 241 of the microneedle 240 can be of any suitable size or diameter. More particularly the portion of the lumen within the proximal end portion 243 is characterized by a first diameter d_1 and the portion of the lumen 241 within the distal end portion 242 is characterized by a second diameter d_2 that is smaller than the first diameter. Similarly stated, the microneedle 240 has a spatially varying inner diameter. The typical diameter range for d_1 is between 0.072 inches (15 gauge needle size) and 0.083 inches (14 gauge needle size). In some embodiments, the diameter d_1 can be any size larger than about 0.072 inches (15 gauge needle size). In other embodiments, the

diameter d1 can be any size larger than about 0.03575 inches (20 gauge needle size). In other yet embodiments, the diameter d1 can be any size larger than about 0.01625 inches (27 gauge needle size). The diameter d2 can range between about 0.00825 inches (33 gauge needle size) and 0.01225 inches (30 gauge needle size). In some embodiments, the diameter d2 can be any size smaller than about 0.01225 inches (30 gauge needle size). In some embodiments, however, the diameter d2 can be any size smaller than about 0.01625 inches (27 gauge needle size). In this manner, the length of the smaller diameter portion (i.e., the distal end portion 242) can be minimized to reduce the frictional losses associated with conveying the medicament through the microneedle 240.

[1062] The portion of the lumen within the proximal end portion 243 is characterized by a length L1 and the portion of the lumen 241 within the distal end portion 242 is characterized by a second length L2 that is smaller than the first length. The length L1 of the proximal end portion 243 of the microneedle 240 can be about 0.300 inches. The length L2 of the distal end portion 242 of the microneedle 240 can be about 0.650 inches. In other embodiments, the length of the distal end portion can be any suitable amount to facilitate targeted injection into a particular region when the transition (or hub) portion 245 is in contact with the target tissue. For example, in some embodiments, the length L2 of the distal end portion 242 of the microneedle 240 (or any of the needles described herein) can be between about 200 microns and about 1500 microns. In other embodiments, the length L2 of the distal end portion 242 of the microneedle 240 (or any of the needles described herein) can be between about 900 microns and about 1100 microns. By reducing the length of the smaller diameter portion of the microneedle 240, the force requirement to produce a desired injection can be minimized.

[1063] In addition to the reduction in the frictional losses, the reduced length of the smaller diameter portion also improves the mechanical integrity of the microneedle. In particular, the reduced length L2 can increase the buckling resistance of the distal end portion 242. This, in turn, can allow the wall thickness of the distal end portion 242 to be decreased.

[1064] The needles 140 and 240 described herein can be used in conjunction with a hub and injector. For example, any of the needles described herein can be used in conjunction with any of the devices shown and described in International Patent Application No. PCT/US2015/036299, filed on June 17, 2015, entitled "Methods and Devices for Treating Posterior Ocular Disorders," which is incorporated herein by reference in its entirety. Additionally, FIG. 7 is a perspective view of a medical injector 300 configured for use with

the needles described herein, according to an embodiment. The medical injector 300 includes a handle 350, a medicament container 330, an actuator 320 (shown in FIG. 8), and a needle assembly 360. The needle assembly 360 includes a hub 370 and a needle 340. The needle 340 can be a microneedle. The medical injector 300 can be configured to deliver a medicament to a region and/or a layer of a target location, for example, an eye of a patient, (e.g., to the SCS of the eye), as described herein.

[1065] FIG. 8 is an exploded view of the medical injector of FIG. 7 in a configuration where the medical injector is not attached to a needle assembly, according to an embodiment. The handle 350 includes a first portion 352 and a second portion 354, that can be coupled together to define an internal region for housing at least a portion of the medicament container 330 and/or the actuator 320. The first portion 352 and the second portion 354 of the handle 350 can be removably or fixedly coupled together using any suitable means, for example, screws, nuts, bolts, rivets, adhesives, a snap-fit mechanism, notches, grooves, indents, a lock, a latch, or any other suitable couple mechanism. The handle 350 includes a gripping portion 356. A plurality of protrusions (e.g., ribs) are disposed on the gripping portion 356 to allow a user to easily grip the handle 350, for example, between the user's index and/or middle finger and thumb. In some embodiments, a plurality of ridges 332 are disposed on an outer surface of the medicament container 330. The ridges 332 can provide an additional gripping surface for the user to securely hold the handle 350. For example, a user can grip the gripping portion 356 with a first hand and grip the ridges 332 with a second hand to limit any unwanted movement of the handle 350 and for more fine control during injection of medicament disposed in the medicament container 330.

[1066] The first portion 352 and/or the second portion 354 of the handle include, in an interior region therein, an actuator engagement portion 358. The actuator engagement portion 358 is configured to mount and/or retain a handle engagement portion 326 of the actuator 320, such that a linear translation of the handle 350 along a longitudinal axis of the medical injector 300 urges the actuator 320 to also translate along the longitudinal axis relative to the medicament container 330. Similarly stated, a user can engage the handle 350 resulting in actuation of the actuator 320.

[1067] The actuator 320 includes the handle engagement portion 326 and a plunger portion 327 movably disposed within an internal volume defined by the medicament container 330. At least a portion of the actuator 320 is slidably disposed in the internal volume defined by

the medicament container 330. Thus, the actuator 320 can be displaced within the internal volume defined by the medicament container 330 for drawing the medicament into and/or expelling the medicament from the internal volume defined by the medicament container 320. As discussed above, the handle engagement portion 326 of the actuator 320 can be fixedly coupled to the handle 350. Thus, any linear displacement of the handle 350 along the longitudinal axis of the medical injector 300 also urges the actuator 320 to slide within the internal volume of the medicament container 330.

[1068] The handle engagement portion 326 of the actuator 320 can be any suitable size, shape, or configuration. For example, as shown in FIG. 8, the handle engagement portion 326 can define an opening configured to receive at least a portion of the actuator engagement portion 358 of the handle. In this manner, the handle 350 and a portion of the actuator 320 can be fixedly and operably coupled to each other, and thereby collectively configured to transfer a force to the medicament container 330 such that a fluid can be conveyed from the medicament container 330, as described in further detail herein.

[1069] The plunger portion 327 of the actuator can be coupled to and/or in contact with a plug 328 which is in fluidic communication with a substance (e.g., a medicament such as, for example, VEGF, a VEGF inhibitor, a combination thereof, or any other medicament described herein) disposed within an internal volume defined by the medicament container 330. The plunger portion 327 of the actuator is configured to be displaced within the internal volume defined by the medicament container 330, for example, due to a force produced by a user, as described herein. In this manner, the actuator 320 can displace the plug 328 within the medicament container to draw in or expel the substance M from the distal tip of the needle 340, as described herein. The sidewalls of the plug 328 can be configured to contact the sidewalls of the medicament container 330 such that the plug 328 forms a substantially fluid-tight seal with the side wall of the medicament container 330, for example, to prevent leakage of the substance M. The plug 328 can be made of an inert and/or biocompatible material which is rigid but soft. Example materials include rubber, silicone, plastic, polymers, any other suitable material or combination thereof. In some embodiments, the plug 328 can be monolithically formed with the actuator 320. Moreover, the plug 328 can have a size, shape and/or can be constructed from a material such that movement of the actuator 320 and/or plug within the medicament container 330 is limited when the force applied is below a predetermined threshold. In this manner, the plug 328 and actuator 320, in conjunction with

the entire medical injector 300 (e.g., the medicament container, the substance being injected and the like) are configured such that a force applied can be sufficient to inject the medicament when a distal end portion of the needle is disposed within a first region of the target tissue (e.g., a suprachoroidal space), but insufficient to inject the medicament when the distal end portion of the needle is disposed within a second region of the target tissue.

[1070] The medicament container 330 defines an internal volume configured to house a medicament (e.g., triamcinolone acetonide, VEGF, VEGF inhibitor, or any other medicament described herein). The medicament container 330 includes a delivery portion 334. The delivery portion 334 includes threads 336 for coupling the delivery portion to a needle assembly 360. Although shown as threads 336, the delivery portion 334 can include any suitable coupling feature configured for coupling the delivery portion with the hub 370, for example, a luer connector, a snap-fit, a latch, a lock, a friction fit coupling, or any other suitable coupling features. The medicament container can be the same as or similar to any of the medicament containers described in U.S. Patent Application No. 14/268,687, entitled "Apparatus and Methods for Ocular Injection," Filed May 2, 2014, which is incorporated by reference herein in its entirety.

[1071] As shown in FIGS. 9-10, the hub 370 includes an engagement portion 371, a coupling portion 372, and a delivery portion 373. An outer sidewall of the engagement portion 371 and an inner sidewall of the coupling portion 372 define a recess 374 configured to receive the delivery portion 334 of the medicament container 330. The inner sidewall of the coupling portion 372 includes threads 375 configured to engage the threads 336 of the medicament container 330, thereby coupling the hub 370 to the medicament container 330. An outer sidewall of the coupling portion 372 includes a set of ridges 376. The ridges 376 can facilitate a user to grip the hub 370, for example, for coupling or uncoupling the hub 370 from the medicament container 330. The engagement portion 371 defines a first fluidic channel 377 configured to engage a fluidic channel of the medicament container 330 and establish fluidic communication between the medicament container 330 and the hub 370. The delivery portion 373 defines a second fluidic channel 378 configured to removably receive the needle 340, for example, a microneedle (e.g., any suitable microneedle described herein). The needle 340 is configured to be disposed within a target tissue, for example, ocular tissue and defines a lumen 341 such that the needle 340 is configured to establish fluidic communication between the medicament container 330 and the portion of the user's

body (e.g., the eye). In some embodiments, the needle 340 can be fixedly disposed in the second fluidic channel 378. In some embodiments, the needle 340 can be monolithically formed with the hub 370 such that the second fluidic channel 378 and the lumen of the needle 341 are continuously and/or seamlessly formed.

[1072] The needle 340 includes a proximal end portion 343, a distal end portion 342, and a hub portion 344 and defines a lumen 341 therethrough. Although shown as having a beveled distal end surface with a sharp tip, the distal end portion 342 of the needle 340 alternatively can have a blunt end. The hub portion 344 of the needle 340 is disposed between the proximal end portion 343 of the needle 340 and the distal end portion 342 of the needle 340. The hub portion 344 serves as a transition area between the proximal end portion 343 of the needle and the distal end portion 342 of the needle. The hub portion 344 can be similar to a conical shape as shown in FIG. 6. In some embodiments, the needle 340 can have a sufficient length so that the hub portion 344 includes a contact surface (not shown) configured to make contact with the eye. The length the distal end portion 342 extends beyond the distal end surface 381 of the hub 370 can be any suitable length, e.g., about 900 microns. In this manner, the contact surface can control the depth of penetration of the distal end portion and/or can form a fluidic seal with the surface of the eye.

[1073] The needle 340 defines a lumen 341. The lumen 341 of the needle 340 can be of any suitable size or diameter. More particularly the portion of the lumen within the proximal end portion 343 is characterized by a first diameter and the portion of the lumen 341 within the distal end portion 342 is characterized by a second diameter that is smaller than the first diameter. Similarly stated, the needle 340 has a spatially varying inner diameter. The typical diameter range for the first diameter is between about 0.072 inches (15 gauge needle size) and about 0.083 inches (14 gauge needle size). In some embodiments, the first diameter can be any size larger than about 0.072 inches (15 gauge needle size). In other embodiments, the first diameter can be any size larger than about 0.03575 inches (20 gauge needle size). In other yet embodiments, the first diameter can be any size larger than about 0.01625 inches (27 gauge needle size). The second diameter can range between about 0.00825 inches (33 gauge needle size) and 0.01225 inches (30 gauge needle size). In some embodiments, the second diameter can be any size smaller than about 0.01225 inches (30 gauge needle size). In some embodiments, however, the second diameter can be any size smaller than about 0.01625 inches (27 gauge needle size). In this manner, the length of the smaller diameter

portion (i.e., the distal end portion) can be minimized to reduce the frictional losses associated with conveying the medicament through the microneedle 340.

[1074] The portion of the lumen within the proximal end portion 343 is characterized by a first length and the portion of the lumen 341 within the distal end portion 342 is characterized by a second length that is smaller than the first length. The first length of the proximal end portion 343 of the needle 340 can be about 0.300 inches. The second length of the distal end portion 342 of the needle 340 can be about 0.650 inches. In other embodiments, the length of the distal end portion can be any suitable amount to facilitate targeted injection into a particular region when the transition (or hub) portion of the needle or the distal surface of the hub is in contact with the target tissue. For example, in some embodiments, the length of the distal end portion 342 of the microneedle 340 (or any of the needles described herein) can be between about 200 microns and about 1500 microns. In other embodiments, the length of the distal end portion 342 of the microneedle 340 (or any of the needles described herein) can be between about 900 microns and about 1100 microns. By reducing the length of the small-diameter portion of the needle 340, the force requirement to produce a desired injection can be minimized.

[1075] In addition reducing the frictional losses by reducing the length of the smaller diameter portion, the reduced length also improves the mechanical integrity of the needle. In particular, the reduced second length can increase the buckling resistance of the distal end portion 342. This, in turn, can allow the wall thickness of the distal end portion 342 to be decreased.

[1076] As shown in FIG. 10, the hub 370 is configured to be physically and fluidically coupled to the needle 340 such that a fluid flow path is defined therebetween. For example, the lumen 341 of the needle 340 is placed in fluid communication with the first fluidic channel 377 and the second fluidic channel 378 of the hub 370 when the needle 340 is physically and fluidically coupled within the second fluidic channel 378. The distal end portion 342 of the needle 340 extends distally from the distal end surface 381 of the hub 370. The hub 370 can be any suitable shape, size, and/or configuration. For example, in some embodiments, the hub 370 can define an inner volume that can house, store, or otherwise contain a therapeutic agent. In other embodiments, the hub 370 can be configured to receive a cartridge (not shown) that container a drug formulation (e.g., a prophylactic agent, a therapeutic agent, and/or a diagnostic agent). The distal end surface 381 of the hub 370 can

be substantially convex or curved to allow the distal end surface to conform to a target tissue (e.g., an ocular tissue). Furthermore, the distal end surface 381 can define a sealing surface configured to form a substantially fluid tight seal with a target tissue, for example, ocular tissue (e.g., the conjunctiva or the sclera) when the distal end surface 381 of the hub 370 is pushed against the ocular tissue (e.g., the conjunctiva or the sclera) as described herein. The distal end surface of the hub can include a sealing portion configured to define a substantially fluid-tight seal with the target surface. The sealing portion can surround a centerline of the needle. While shown as including the hub 370, the apparatus can include any suitable rigid hub. The hub 370 can be formed from a relatively rigid material such as a metal or hard plastic. The hub 370 can be the same or similar to any of the hubs described in U.S. Patent Application No. 14/268,687, entitled "Apparatus and Methods for Ocular Injection," Filed May 2, 2014, which is incorporated by reference herein in its entirety.

[1077] The hub 370 can be formed as a monolithic structure, as shown in FIG. 10. Alternatively, in some embodiments, the hub can be formed from separate portions coupled together to form the hub 370. For example, FIGS. 11A-11C show a needle assembly 460 according to an embodiment. FIG. 11A is an exploded view of the needle assembly 460. The needle assembly 460 includes a hub 470 and a needle 440. The hub 470 has a first portion 479 and a second portion 480. The first portion 479 and the second portion 480 can be formed separately and coupled together. The first portion 479 and the second portion 480 can be coupled together through welding, the application of an adhesive, or any other suitable means. As shown in FIG. 11A, the second portion 480 can be securely attached to the needle 440 before being coupled to the first portion 479. The needle 440 can be a variable diameter cannula as described with reference to needles 140, 240, and 340 above.

[1078] FIG. 11B is a side view of the needle assembly 460 in an assembled configuration where the first portion 479 has been coupled to the second portion 480. The hub 470 has a distal end surface 481 that is configured to contact a target surface of a target tissue. The target tissue can be for example, an eye, and the target surface can be, for example, a conjunctiva of the eye or a sclera of the eye. The distal end surface of the hub can include a sealing portion configured to define a substantially fluid-tight seal with the target surface. The sealing portion can surround a centerline of the needle 440.

[1079] FIG. 11C is a cross-sectional view of the needle assembly 460 taken along line C-C in FIG. 11B. The first portion 479 of the hub 470 can include threads 475 to couple the

needle assembly 460 to a medicament container. Although shown as threads 475, the hub 470 can include any suitable coupling feature configured for coupling the hub 470 with a medicament container, for example, a luer connector, a snap-fit, a latch, a lock, a friction fit coupling, or any other suitable coupling features.

[1080] The needle 440 can include any suitable needle as described herein, for example, a microneedle (e.g., a 27 gauge, 30 gauge, or even smaller needle). The needle 440 can have multiple different diameters. Further, the needle 440 can have any suitable length, e.g., a fixed length of about 900 μm or about 1100 μm , or any length therebetween. Additionally, the lengths of the distal end portion 442 and the proximal end portions 443 can be any suitable length. For example, if the inner diameter of the distal end portion 442 is 30 gauge or smaller, a length of the distal end portion 442 can be such that the medicament is conveyed through the lumen 441 when a force of less than about 6 N is exerted on an actuation rod. Additionally, the length of the distal end portion 442 of the needle 440 can be less than the overall length of the needle 440. Similarly, the length that the distal end portion 442 extends beyond the distal end surface 481 of the hub 470 can be any suitable length, e.g., about 900 microns. The distal tip of the needle 440 can define a sharp and/or beveled tip such that the needle 440 is configured to pierce a target location, for example, a bodily tissue (e.g., ocular tissue). In this manner, the distal tip can be disposed within a first region and/or a second region of the target location, as described herein. The needle 440 defines a lumen 441, which is configured to be in fluidic communication with a substance disposed within an internal volume defined by a medicament container and/or an internal volume 482 defined by the hub 470. In this manner, the needle 440 is configured to establish fluid communication between the medicament container and the target location, for example, the first region of the target location, as described herein. In some embodiments, the first region of the target location can have a first density and the second region can have a second density, which is higher than the first density. In some embodiments, the first region of the target location produces a first backpressure on the distal tip of the needle, and the second region produces a second backpressure on the distal tip of the needle, which is higher than the first backpressure. In other words, the first region of the target location produces a first pressure that resists and/or opposes flow from the distal tip of the needle, and the second region produces a second pressure that resists and/or opposes flow from the distal tip of the needle, which is higher than the first pressure. In some embodiments, the target location can be an eye such that the first region is a suprachoroidal space of the eye, and the second region is a sclera of the eye.

[1081] Although shown as being a fixed needle, in some embodiments, such as the embodiments shown in FIGS. 12-17, the needle assembly can move relative to the medicament container to have variable needle length. In some embodiments, an apparatus for injecting a medicament into a target tissue can include a medical injector and a hub with a compressible member disposed therebetween. The compressible member is configured to compress and/or deform in response to a force to allow adjustment of a length of a needle. Similarly stated, the compressible member can deform to allow the length of the needle to extend distally from the hub to be adjusted. This arrangement can allow, for example, the adjustment of a distance the needle penetrates into a target tissue (i.e., the insertion depth of the needle), for example, an ocular tissue. Referring now to FIGS. 12-15, an apparatus 500 includes a medical injector 510, a hub 570, and a compressible member 578. The medical injector 510 includes an actuator rod 520, a medicament container 530, and a needle 540. While shown as including the medical injector 510, the apparatus 500 can include any other suitable medical injector. Examples of medical injectors which can be used in the apparatus 500 are described in U.S. Patent Application No. 14/268,687, now U.S. Patent Publication No. 2015/0038905 (also referred to herein as “the ‘687 application”), filed May 02, 2014, and entitled “Apparatus and Methods for Ocular Injection,” the disclosure of which is incorporated by reference herein in its entirety.

[1082] The needle 540 can be any suitable puncture member configured to puncture a target tissue of the types shown and described herein. For example, the needle 540 can be a microneedle configured to puncture ocular tissue. In some embodiments, the needle 540 can be a 30 gauge microneedle, a 32 gauge microneedle or a 34 gauge microneedle (or any size within the range of about 30 gauge to about 34 gauge). In some embodiments, such a microneedle can be substantially similar to or the same as the puncture members and microneedles described in the ‘009 PCT application incorporated by reference above. In some embodiments, the shape and/or size of the needle 540 can correspond, at least partially, with at least a portion of a target tissue. For example, in some embodiments, the length of the needle 540 can correspond with a thickness of a portion of ocular tissue such that when the needle 540 is inserted into the ocular tissue, at least a portion of the needle 540 is disposed within the sclera or suprachoroidal space of the eye, as described in further detail herein. Moreover, as described herein, the exposed length of the needle can be adjusted. The needle 540 defines a lumen 541 that extends through a proximal end 543 and a distal end 542 of the needle 540. The distal end 542 of the needle 540 can include a bevel or a sharpened tip

configured to puncture a target tissue. At least a portion of the proximal end 543 of the needle 540 can be disposed in a first passageway 576 defined by the hub 570 and a second passageway 579 defined by the compressible member 578, as described herein.

[1083] The medicament container 530 of the medical injector 510 has a proximal end portion 532 and a distal end portion 534. The medicament container 530 defines an inner volume 536 that can store, house, and/or otherwise contain a substance (e.g., a medicament, a prophylactic agent, a therapeutic agent, and/or a diagnostic agent). For example, in some embodiments, a cartridge or the like containing a drug formulation or a medicament (e.g., a VEGF, a VEGF inhibitor, triamcinolone acetonide, any other medicament described herein, or a combination thereof) can be disposed within the inner volume 536 of the medicament container 530. In other embodiments, a drug formulation can be disposed directly within the inner volume 536 (e.g., without a cartridge or other intermediate reservoir). In some embodiments, the inner volume 536 can contain a drug formulation with a volume of about 0.5 mL or less. In other embodiments, the inner volume 536 can contain a drug formulation with a volume of about 0.1 mL. In still other embodiments, the inner volume 536 can contain a drug formulation with a volume greater than about 0.5 mL. In some embodiments, the medicament container 530 can be substantially similar to any medicament container described in the '687 application.

[1084] The proximal end portion 532 of the medicament container 530 is substantially open to receive the actuation rod 520. More specifically, a distal end portion 524 of the actuation rod 520 is disposed within the inner volume 536 and can be moved between a first position (e.g., a proximal position) and a second position (e.g., a distal position). Said another way, the distal end portion 524 of the actuation rod 520 can move an injection distance within the inner volume 536. A sealing member such as, for example, a plug or elastomeric member can be coupled to and/or moved by the distal end portion 524 of the actuation rod 520. The sealing member can be configured to form a friction fit with one or more surfaces of the medicament container 530 that define the inner volume 536. In this manner, the sealing member and the medicament container 530 can form a substantially fluid-tight seal that substantially isolates a portion of the inner volume 536 that is distal to the seal member from a portion of the inner volume 536 that is proximal to the sealing member. Said another way, the medicament container 530 and the actuation rod 520 form at least a portion of a syringe.

[1085] The distal end portion of the medicament container 530 is coupled to compressible member 578 and the hub 570 such that the compressible member 578 is disposed between the hub 570 and the distal end portion 534 of the medicament container 530. As described in more detail below, the compressible member 578 and the hub 570 can be coupled to the medicament container 530 in any suitable manner. For example, in some embodiments, the compressible member 578 and/or the hub 570 can be a single assembly that includes a luer fitting configured to be coupled to a corresponding tapered portion of the medicament container 530 (which can be, for example, a prefilled syringe). In other embodiments, the compressible member 578 and the hub 570 can be separately constructed and/or separately coupled to the medicament container by an adhesive, threaded fitting or any other suitable mechanism.

[1086] The hub 570 defines a first passageway 576 configured to receive the needle 540 therethrough such that the distal end 542 of the needle extends the substantially the length of the first passageway 576, and can extend past a distal end surface 575 of the hub 570. The distal end surface 575 of the hub 570 can be substantially convex or curved to allow the distal end surface to conform to a target tissue (e.g., an ocular tissue). Furthermore, the distal end surface 575 can define a sealing surface configured to form a substantially fluid tight seal with a target tissue, for example, ocular tissue (e.g., the conjunctiva) when the distal end surface 575 of the hub 570 is pushed against the ocular tissue (e.g., the conjunctiva), as described herein. The sealing surface 575 can surround a centerline of the needle 540. While shown as including the hub 570, the apparatus 500 can include any suitable rigid hub. Examples of hubs that can be used with the apparatus 500 are described in the '687 application. The hub 570 can be formed from a relatively rigid material such as a metal or hard plastic.

[1087] The compressible member 578 is disposed between the medicament container 530 and the hub 570, and is configured to compress. Similarly stated, the compressible member 578 is formulated and/or constructed to experience a reduction in thickness in response to a force exerted on the medical injector 510, and an opposite force exerted by the hub 570, as described herein. The compressible member 578 defines a second passageway 579 configured to receive at least a portion of the proximal end 543 of the needle 540. The second passageway 579 of the compressible member 578 is in communication with and/or aligned with the first passageway 576 of the hub 570 such that the needle 540 is disposed

through the first passageway 576 and the second passageway 579. The compressible member 578 can be formed from a substantially compressible material such as, for example, rubber, silicone, hydrogels, sol-gels, foam, sponge, aerogels, a non-linear elastic material, any other compressible material or a combination thereof. In some embodiments, the compressible member 578 can include a spring such as, for example, helical, compression, extension, spring washers, Belleville washers, tapered, any other type of spring, or any other suitable biasing member. The distal end portion 542 of the needle extends distally from the distal end surface 575 of the hub 570 by a first length when the compressible member 578 has a first thickness and by a second length when the compressible member 578 has a second thickness. The second length can be about 900 microns and about 1100 microns.

[1088] In some embodiments, the maximum reduction in thickness that the compressible member 578 can undergo in response to a predetermined force (e.g., in the range of about 0.5 N to about 6 N, and more particularly in the range of about 0.5 N to about 2 N) exerted on the medical injector 510 can be configured to correspond to a maximum insertion depth of the distal end 542 of the needle 540 into a target tissue (e.g., ocular tissue). For example, in some embodiments, the compressible member 578 can be configured to experience a maximum reduction in thickness of about 900 μm to about 1,200 μm in response to a force in the range of about 0.5 N to about 6 N exerted on the proximal end portion 522 of the actuation rod 520. In other embodiments, the compressible member 578 can be configured to experience a maximum reduction in thickness of about 900 μm to about 1,200 μm in response to a force in the range of about 0.5 N to about 2 N exerted on the proximal end portion 522 of the actuation rod 520. In other embodiments, the compressible member 578 can be configured to experience a maximum reduction in thickness of about 300 μm in response to a force in the range of less than about 6 N. This deformation and/or reduction in thickness allows the hub 570 to move proximally relative to the medicament container 530 a distance of about 900 μm to about 1,200 μm , thus exposing the distal end 542 of the needle 540 from the distal end surface 575 of the hub 570 by the same or similar distance. In this manner, the maximum depth the distal end 542 of the needle 540 can be inserted into a target tissue (e.g., an ocular tissue) or otherwise the insertion depth of the needle 540 can be controlled. In some embodiments, the ratio of the thickness of the compressible member 578 and the insertion depth of the needle 540 can be configured such that the distal end 542 of the needle 540 can be inserted to a desired depth in a target tissue (e.g., within or near the suprachoroidal space of ocular tissue) when a predetermined force, for example, in the range

of about 0.5 N to about 6 N (or more particularly, the range of about 0.5 N to about 2 N) is applied on the medical injector 510, as described herein.

[1089] The compressible member 578 can have any shape or size. For example, the compressible member 578 can include a circular disc, a rectangular disc, a square disc, a ring, multiple pieces of compressible material disposed between the hub 570 and the medicament container 530, or any other suitable shape or size. The compressible member 578 can be coupled to a distal end surface of the medicament container 530 by any suitable mechanism. In some embodiments, the compressible member 578 can be coupled to the medicament container 530 and the hub 570 using, for example, adhesives, hot welding, fusion bonding, screws, nuts, bolts, rivets, any other suitable coupling mechanism or combination thereof. In other embodiments, an adapter (e.g., a luer adapter, a collar or the like) or any other piece can be disposed between the hub 570 and the medicament container 530, and can function to couple the compressible member 578 to the medicament container 530.

[1090] As described herein, the apparatus 500 can be used to control the insertion depth of a distal end 542 of the needle 540 into a target tissue, for example, an ocular tissue. In this manner, the apparatus 500 can be used to move (or guide the movement of) the distal end 542 of the needle 540 to a desired depth in a target tissue to enable delivery of the medicament to a target location of the target tissue (e.g., the suprachoroidal space of ocular tissue). For example, in some embodiments, the apparatus 500 can be configured to deliver a medicament to the suprachoroidal space of the eye. FIG. 13 shows a portion of the apparatus 500 that includes the hub 570 and the compressible member 578 in a first configuration. In the first configuration, the distal end surface 575 of the hub 570 can be disposed on and in contact with the conjunctiva C of an eye. As described herein, the hub 570 is formed from a rigid material such that the distal end surface 575 is configured to form a substantially fluid tight seal with the conjunctiva C of the eye. Furthermore, in the first configuration, the compressible member 578 is uncompressed and has a first thickness t_1 . The first thickness t_1 is such that in the first configuration, the distal end 542 of the needle 540 is disposed within the hub 570 (i.e., the distal end 542 of the needle 540 does not protrude beyond the distal end surface 575 of the hub 570). In this manner, for example, the hub 570 and the compressible member 578 can serve as a safety mechanism to prevent accidental puncturing or otherwise sticking by the distal end 542 of the needle 540 both before and after use.

[1091] In the second configuration, as shown in FIG. 14, a force in a direction shown by the arrow F can be exerted on the apparatus 500, for example, on the proximal end portion 522 of the actuation rod 520. Alternatively, the force F can be applied directly to the medicament container 530. As shown, the force F can urge the distal end surface 575 of the hub 570 to press against the conjunctiva C. Since the hub 570 is a substantially rigid member that has a stiffness substantially greater than the stiffness of the conjunctiva C (e.g., a stiffness substantially similar to a stiffness of stainless steel), application of the force F deforms the conjunctiva C, without causing substantial deformation of the hub 570. The magnitude of the force F can be insufficient to depress the distal end surface 575 of the hub 570 any further into the conjunctiva C. For example, it is known that practitioners generally prefer to limit the manual force applied to the eye within the range of about 0.5 N to about 6 N (or more particularly, within the range of about 0.5 N to about 2 N). Thus, the hub 570 and the compressible member 578 can be configured to deform and/or respond to the Force within this range to facilitate the desired penetration of the needle 540. In particular, the force F can be sufficient to compress the compressible material 578 such that the compressible material 578 experiences a reduction in thickness for the first thickness t_1 to a second thickness t_2 . This allows the medicament container 530 and/or needle 540 to move proximally relative to the hub 570. This proximal movement urges the distal end 542 of the needle 540 to also move proximally relative to the eye such that the distal end 542 of the needle 540 pierces the conjunctiva C and is disposed in the sclera S of the eye.

[1092] In a third configuration shown in FIG. 15, the force F can be maintained such that the thickness of the compressible member reduces to a third thickness t_3 . This further reduction in the thickness of the compressible member 578 allows the distal end 542 of the needle 540 to protrude further into the eye until the distal end 542 is disposed in a suprachoroidal space SCS (e.g., the target layer) of the eye but does not pierce further into the eye (e.g., the retina R, the vitreous or other layers). When the device 500 is in the third configuration, the medicament can be injected into the suprachoroidal space SCS, either manually or using an injection assist assembly examples of which are described in the '687 application. In some embodiments, the thickness and/or the compressibility (or otherwise stiffness coefficient) of the compressible member 578 can be configured such that the thickness of the compressible material 578 cannot easily be reduced to a thickness less than t_3 . In this manner, the compressible member 578 can control and/or limit the insertion depth of the distal end 542 of the needle 542, for example, to be in the range of about 900 μm to about 1,200 μm . This

distance can be sufficient to allow the distal end 542 of the needle 540 to be inserted to the suprachoroidal space SCS of the eye but can prevent any travel of the distal end 542 of the needle 540 beyond the suprachoroidal space SCS into the retina R. Thus, the compressible member 578 can also serve as a stopping mechanism to control the insertion depth of the distal tip 542 of the needle 540 to be within a desired range.

[1093] For example, in some embodiments, the compressible member 578 can be constructed from a material (or combination of materials) such that the rate of deformation is non-linear. In particular, the rate of deformation can decrease when the force F exceeds a certain threshold (e.g., 6N), thereby limiting any further deformation. In some embodiments, for example, the compressible member 578 can be a composite article constructed from layers of different materials.

[1094] Although the hub 570 is described above as being substantially stiff (and non-deformable), in some embodiments, the hub 570 can have a stiffness that is intermediate to the stiffness of the conjunctiva C and the sclera S. In such embodiments, application of the force F can urge the hub 570 to deform the conjunctiva C until the distal end surface 575 of the hub 570 is proximate to the sclera S. Since the stiffness of the hub 570 is less than the stiffness of the sclera S, further application of the force F will urge the distal end surface 575 of the hub 570 to deform without any substantial deformation of the sclera S. In this manner, the hub 570 can prevent application of an excessive force from causing damage to or otherwise deformation and/or piercing of the internal layers of the eye.

[1095] Although the compressible member 578 is described above as optionally being configured to limit its deformation, in some embodiments, an apparatus can include a stopping mechanism to stop or otherwise limit compression of a compressible member to define a maximum insertion depth of a distal end of a needle into a target tissue. Referring now to FIGS. 16 and 17, an apparatus 600 includes a medical injector 610, a needle 640, a hub 670, a compressible member 678, and a stopping mechanism 680. The medical injector 610 includes a medicament container 630, and an actuator (not shown). The medical injector 610 can be substantially similar to the medical injector 510 and is therefore, not described in further detail herein.

[1096] The hub 670 and the compressible member 678 can be substantially similar to hub 570 and the compressible member 578, respectively described with respect to the apparatus

500. The stopping mechanism 680 includes a backstop 681, and a set of stoppers 682. A distal end portion of the medicament container 630 is coupled to the backstop 681 such that the backstop 681 is disposed between the medicament container 630 and the compressible member 678. The backstop 681 can be formed a substantially rigid material such as, for example, metals, or plastic. In some embodiments, the backstop 681 can be fixedly coupled to the distal end portion of the medicament container 630 and/or the compressible member, for example, with adhesives, hot welding, fusion bonding, screws, nuts, bolts, rivets, and the likes. In some embodiments, the backstop 681 can be monolithically formed with the medicament container 630. The backstop 681 defines a bore 683 within which at least a portion of a proximal end 643 of the needle 640 is disposed.

[1097] The stoppers 682 can includes rods or otherwise protrusions. A distal end portion of each of the stoppers 682 is fixedly coupled to the hub 670. For example, the distal end portion of the stoppers 682 can be disposed within cavities defined by the hub 670, screwed, snap-fitted, press-fitted, friction-fitted, fixedly coupled to the hub 670 using adhesives, hot welding, fusion bonding, or any other suitable coupling mechanism. In some embodiments, the stoppers 682 can be monolithically formed with the hub 670. The stoppers 682 can be formed from a substantially rigid material such as, for example, metals or plastics. At least a portion of each of the stoppers 682 is disposed within throughholes defined within the compressible member 678 such that the stoppers 682 extend through the compressible member 678. Thus, the stoppers 682 are free to slide, move or otherwise displace with the throughholes defined by the compressible member 678. A proximal end portion of each of the stoppers 682 is disposed within a corresponding channel from set of channels 684 defined by the backstop 681 such that the proximal end portion of the stoppers 682 is free to slide within the channels 684. In some embodiments, a protrusion 685 can be disposed on the proximal end portion of the stopper 682. The protrusion 685 can, for example, be configured to interact with a set of grooves or notches defined in the corresponding channel 684 to allow displacement of the protrusions 685 within the channels 684 in fixed or otherwise predetermined increments. In this manner, the protrusions 685 can allow the compressible member 678 to experience a reduction in thickness, and the hub 670 to move proximally relative to the medicament container 630 in fixed increments. Furthermore, the channels 684 can have a predetermined length to allow displacement of the proximal end portion of the stoppers 682 until the distal end portion of the stoppers 682 contacts a back wall 686 of the channel 685. In this manner, the channels 684 and/or the backstop 681 can limit the

displacement of the distal end portion of the stoppers 682 proximally relative to the medicament container 630 and thereby, define the maximum length that a distal end 642 of the needle 640 can emerge from a distal end surface 675 of the hub 670. Said another way, the length of the channels 684 defined by the backstop 681 can be configured to define the maximum insertion depth of the distal end 642 of the needle 640 in a target tissue (e.g., ocular tissue).

[1098] Expanding further, FIG. 16 shows the apparatus 600 in a first configuration. In the first configuration, the distal end surface 675 of the hub 670 can be disposed against a conjunctiva C of ocular tissue. Furthermore, the compressible member 678 is uncompressed and defines a first thickness t_4 . A distal end 642 of the needle 640 is disposed within a first passageway 676 defined by the hub 670 such that a distal tip of the needle 640 is disposed within the first passageway 676 and does not protrude beyond a distal end surface 675 of the hub 670. At least a portion of the proximal end 643 of the needle 640 is disposed within the bore 683 defined by the backstop 681 and passes through a second passageway 679 defined by the compressible member 678. The needle 640 defines a lumen 641 therethrough configured to deliver a substance, for example, a medicament disposed within the medicament chamber 630 to a target location in the ocular tissue, for example, the suprachoroidal space SCS. The proximal end portion of each of the stoppers 682 is disposed within the corresponding channel 684 defined by the backstop 681 such that the proximal ends of the stoppers 682 are distal to the back wall 686 of the channels 684.

[1099] A user can exert a force in the direction shown by the arrow F on the medical injector 610 to urge the apparatus into a second configuration, as shown in FIG. 17. The distal end surface 675 of the hub 670 can press against the conjunctiva and form a substantially fluid tight seal with the conjunctiva C, as described herein. Any further movement of the hub 670 however, is prevented by the conjunctiva C and/or the underlying ocular tissue. Maintaining or increasing the magnitude of the force F can urge the medical injector 610 and thereby the medicament container 630 and/or the needle 640 to move proximally relative to the hub 670. This urges the distal end 642 of the needle 640 to pierce through the conjunctiva C and into the sclera S of the eye. This also urges the stoppers 682 to move proximally relative to the hub 670 within the channels 684. The force F compresses the compressible member 678 between the rigid backstop 681 and the rigid hub 670. As shown in FIG. 17, the force F can be maintained until the back wall 686 contacts the proximal end of the stoppers 682 and the

compressible member is compressed to a second thickness t_5 . Any further reduction in thickness of the compressible member 678 is prevented by the contact of the back wall 686 with the proximal end of the stoppers 682. In this manner, the stopping mechanism 680 can define the maximum reduction in thickness that the compressible member 678 can experience, and thereby the maximum distance the distal end 642 of the needle 640 can protrude into the eye, i.e., the maximum insertion depth of the distal end 642 of the needle 640. For example, the stopping mechanism 680 can be configured to limit the maximum insertion depth of the distal end 642 of the needle 640 to the suprachoroidal space SCS (e.g., about 900 μm to about 1,200 μm) and prevent insertion of the distal end 642 of the needle 640 into the retina R of the eye.

[1100] The embodiments described herein can be formed or constructed of one or more biocompatible materials. Examples of suitable biocompatible materials include metals, glasses, ceramics, or polymers. Examples of suitable metals include pharmaceutical grade stainless steel, gold, titanium, nickel, iron, platinum, tin, chromium, copper, and alloys thereof. The polymer may be biodegradable or non-biodegradable. Examples of suitable biodegradable polymers include polylactides, polyglycolides, polylactide-co-glycolides (PLGA), polyanhydrides, polyorthoesters, polyetheresters, polycaprolactones, polyesteramides, poly(butyric acid), poly(valeric acid), polyurethanes and copolymers and blends thereof. Examples of non-biodegradable polymers include nylons, polyesters, polycarbonates, polyacrylates, polymers of ethylene-vinyl acetates and other acyl substituted cellulose acetates, non-degradable polyurethanes, polystyrenes, polyvinyl chloride, polyvinyl fluoride, poly(vinyl imidazole), chlorosulphonate polyolefins, polyethylene oxide, blends and copolymers thereof.

[1101] The microneedles described herein can be fabricated by a variety of methods. For example, in some embodiments, the hollow microneedle is fabricated using a laser or similar optical energy source. In one example, a microcannula may be cut using a laser to represent the desired microneedle length. The laser may also be used to shape single or multiple tip openings. Single or multiple cuts may be performed on a single microcannula to shape the desired microneedle structure. In one example, the microcannula may be made of metal such as stainless steel and cut using a laser with a wavelength in the infrared region of the light spectrum (0.7-300 μm). Further refinement may be performed using metal electropolishing techniques familiar to those in the field. In another embodiment, the microneedle length and

optional bevel is formed by a physical grinding process, which for example may include grinding a metal cannula against a moving abrasive surface. The fabrication process may further include precision grinding, micro-bead jet blasting and ultrasonic cleaning to form the shape of the desired precise tip of the microneedle.

[1102] In some embodiments, a variable diameter needle of the types shown and described herein (e.g., needle 240) can be fabricated by a deep drawing process. This process can be used to produce the monolithic needles having a variable diameter, as described herein. Moreover, the deep drawing process can produce a needle having a thin wall thickness.

[1103] A wide range of ocular diseases and disorders may be treated by the methods and devices described herein. Non-limiting examples of ocular diseases include uveitis, glaucoma, diabetic macular edema or retinopathy, macular degeneration, retinoblastoma, and genetic diseases. The methods described herein are particularly useful for the local delivery of drugs that need to be administered to the posterior region of the eye, for example the retinochoroidal tissue, macula, and optic nerve in the posterior segment of the eye. In one embodiment, the delivery methods and devices described herein may be used in gene-based therapy applications. For example, the methods may administer a fluid drug formulation into the suprachoroidal space to deliver select DNA, RNA, or oligonucleotides to targeted ocular tissues.

[1104] The microneedles can be used to target delivery to specific tissues or regions within the eye or in neighboring tissue. In various embodiments, the methods may be designed for drug delivery specifically to the sclera, the choroid, the Bruch's membrane, the retinal pigment epithelium, the subretinal space, the retina, the macula, the optic disk, the optic nerve, the ciliary body, the trabecular meshwork, the aqueous humor, the vitreous humor, and other ocular tissue or neighboring tissue in need of treatment.

[1105] A wide range of drugs may be formulated for delivery to ocular tissues using the present systems and devices described herein. Moreover, any of the delivery devices and/or methods described herein can involve, include and/or contain any of the drugs described herein. For example, in some embodiments, the medicament container 130, 330, 530, 630, or any other medicament container can contain any of the drugs and/or formulations described herein. As used herein, the term "drug" (or "medicament") refers to any prophylactic, therapeutic, or diagnostic agent (e.g., a contrast agent). The drug may be selected from

suitable proteins, peptides and fragments thereof, which can be naturally occurring, synthesized or recombinantly produced. Representative examples of types of drugs for delivery to ocular tissues include antibodies, anti-viral agents, chemotherapeutic agents (e.g., topoisomerase inhibitors), analgesics, anesthetics, aptamers, antihistamines, anti-inflammatory agents, and anti-neoplastic agents. In one embodiment, the drug is triamcinolone or triamcinolone acetonide.

[1106] The “therapeutic formulation,” medicament, or drug delivered via the methods and devices provided herein in one embodiment, is an aqueous solution or suspension, and comprises an effective amount of the drug or therapeutic agent, for example, a cellular suspension. In some embodiments, the therapeutic formulation is a fluid drug formulation. The “drug formulation” is a formulation of a drug, which typically includes one or more pharmaceutically acceptable excipient materials known in the art. The term “excipient” refers to any non-active ingredient of the formulation intended to facilitate handling, stability, dispersibility, wettability, release kinetics, and/or injection of the drug. In one embodiment, the excipient may include or consist of water or saline.

[1107] The therapeutic formulation delivered to the suprachoroidal space of the eye of a human subject for the treatment of uveitis (e.g., non-infectious uveitis), macular edema associated with uveitis (e.g., non-infectious uveitis), macular edema associated with RVO or wet AMD, may be in the form of a liquid drug, a liquid solution that includes a drug or therapy in a suitable solvent, or liquid suspension. The liquid suspension may include microparticles or nanoparticles dispersed in a suitable liquid vehicle for infusion. In various embodiments, the drug is included in a liquid vehicle, in microparticles or nanoparticles, or in both the vehicle and particles. The drug formulation is sufficiently fluid to flow into and within the suprachoroidal space, as well as into the surrounding posterior ocular tissues. In one embodiment, the viscosity of the fluid drug formulation is about 1 cP at 37 °C.

[1108] In one embodiment, the drug formulation (e.g., fluid drug formulation) includes microparticles or nanoparticles, either of which includes at least one drug. Desirably, the microparticles or nanoparticles provide for the controlled release of drug into the suprachoroidal space and surrounding posterior ocular tissue. As used herein, the term “microparticle” encompasses microspheres, microcapsules, microparticles, and beads, having a number average diameter of from about 1 μm to about 100 μm , for example from about 1 to about 25 μm , or from about 1 μm to about 7 μm . “Nanoparticles” are particles having an

average diameter of from about 1 nm to about 1000 nm. The microparticles, in one embodiment, have a D_{50} of about 3 μm or less. In a further embodiment, the D_{50} is about 2 μm . In another embodiment, the D_{50} of the particles in the drug formulation is about 2 μm or less. In another embodiment, the D_{50} of the particles in the drug formulation is about 1000 nm or less. In one embodiment, the drug formulation comprises microparticles having a D_{99} of about 10 μm or less. The microparticles, in one embodiment, have a D_{50} of about 3 μm or less. In a further embodiment, the D_{50} is about 2 μm . In another embodiment, the D_{50} of the particles in the drug formulation is about 2 μm or less. In another embodiment, the D_{50} of the particles in the drug formulation is about 1000 nm or less. In one embodiment, the drug formulation comprises microparticles having a D_{99} of about 10 μm or less. The microparticles, in one embodiment, have a D_{50} of about 3 μm or less. In a further embodiment, the D_{50} is about 2 μm . In another embodiment, the D_{50} of the particles in the drug formulation is about 2 μm or less. In another embodiment, the D_{50} of the particles in the drug formulation is about 100 nm to about 1000 nm. In one embodiment, the drug formulation comprises microparticles having a D_{99} of about 1000 nm to about 10 μm . The microparticles, in one embodiment, have a D_{50} of about 1 μm to about 5 μm or less. In another embodiment, the drug formulation comprises particles having a D_{99} of about 10 μm . In another embodiment, the D_{99} of the particles in the formulation is less than about 10 μm , or less than about 9 μm , or less than about 7 μm or less than about 3 μm . In a further embodiment, the microparticles or nanoparticles comprise an anti-inflammatory drug. In a further embodiment, the anti-inflammatory drug is triamcinolone.

[1109] Microparticles and nanoparticles may or may not be spherical in shape. “Microcapsules” and “nanocapsules” are defined as microparticles and nanoparticles having an outer shell surrounding a core of another material. The core can be liquid, gel, solid, gas, or a combination thereof. In one case, the microcapsule or nanocapsule may be a “microbubble” or “nanobubble” having an outer shell surrounding a core of gas, wherein the drug is disposed on the surface of the outer shell, in the outer shell itself, or in the core. (Microbubbles and nanobubbles may respond to acoustic vibrations as known in the art for diagnosis or to burst the microbubble to release its payload at/into a select ocular tissue site.) “Microspheres” and “nanospheres” can be solid spheres, can be porous and include a sponge-like or honeycomb structure formed by pores or voids in a matrix material or shell, or can include multiple discrete voids in a matrix material or shell. The microparticles or

nanoparticles may further include a matrix material. The shell or matrix material may be a polymer, amino acid, saccharide, or other material known in the art of microencapsulation.

[1110] The drug-containing microparticles or nanoparticles may be suspended in an aqueous or non-aqueous liquid vehicle. The liquid vehicle may be a pharmaceutically acceptable aqueous solution, and optionally may further include a surfactant. The microparticles or nanoparticles of drug themselves may include an excipient material, such as a polymer, a polysaccharide, a surfactant, etc., which are known in the art to control the kinetics of drug release from particles.

[1111] In one embodiment, the drug formulation further includes an agent effective to degrade collagen or GAG fibers in the sclera, which may enhance penetration/release of the drug into the ocular tissues. This agent may be, for example, an enzyme, such as hyaluronidase, a collagenase, or a combination thereof. In a variation of this method, the enzyme is administered to the ocular tissue in a separate step from—preceding or following—infusion of the drug. The enzyme and drug are administered at the same site.

[1112] In another embodiment, the drug formulation is one which undergoes a phase change upon administration. For instance, a liquid drug formulation may be injected through hollow microneedles into the suprachoroidal space, where it then gels and the drug diffuses out from the gel for controlled release.

[1113] The therapeutic substance in one embodiment is formulated with one or more polymeric excipients to limit therapeutic substance migration and/or to increase viscosity of the formulation. A polymeric excipient may be selected and formulated to act as a viscous gel-like material in-situ and thereby spread into a region of the suprachoroidal space and uniformly distribute and retain the drug. The polymer excipient in one embodiment is selected and formulated to provide the appropriate viscosity, flow and dissolution properties. For example, carboxymethylcellulose is used in one embodiment to form a gel-like material in the suprachoroidal space. The viscosity of the polymer in one embodiment is enhanced by appropriate chemical modification to the polymer to increase associative properties such as the addition of hydrophobic moieties, the selection of higher molecular weight polymer or by formulation with appropriate surfactants.

[1114] The dissolution properties of the therapeutic formulation in one embodiment is adjusted by tailoring of the water solubility, molecular weight, and concentration of the

polymeric excipient in the range of appropriate thixotropic properties to allow both delivery through a small gauge needle and localization in the suprachoroidal space. The polymeric excipient may be formulated to increase in viscosity or to cross-link after delivery to further limit migration or dissolution of the material and incorporated drug.

[1115] Water soluble polymers that are physiologically compatible are suitable for use as polymeric excipients in the therapeutic formulations described herein, and for delivery via the methods and devices described herein include but are not limited to synthetic polymers such as polyvinylalcohol, polyvinylpyrrolidone, polyethylene glycol, polyethylene oxide, polyhydroxyethylmethacrylate, polypropylene glycol and propylene oxide, and biological polymers such as cellulose derivatives, chitin derivatives, alginate, gelatin, starch derivatives, hyaluronic acid, chondroitin sulfate, dermatin sulfate, and other glycosaminoglycans, and mixtures or copolymers of such polymers. The polymeric excipient is selected in one embodiment to allow dissolution over time, with the rate controlled by the concentration, molecular weight, water solubility, crosslinking, enzyme lability and tissue adhesive properties of the polymer.

[1116] In one embodiment, a viscosity modifying agent is present in a therapeutic formulation delivered by one of the methods and/or devices described herein. In a further embodiment, the viscosity modifying agent is polyvinyl alcohol, polyvinyl pyrrolidone, methyl cellulose, hydroxypropyl cellulose, hydroxyethyl cellulose, hydroxymethyl cellulose or hydroxypropyl cellulose. In another embodiment, the formulation comprises a gelling agent such as poly(hydroxymethylmethacrylate), poly(N-vinylpyrrolidone), polyvinyl alcohol or an acrylic acid polymer such as Carbopol.

[1117] In one embodiment, the therapeutic formulation is delivered via one of the methods and or devices described herein as a liposomal formulation.

[1118] Liposomes can be produced by a variety of methods. Bangham's procedure (J. Mol. Biol., J Mol Biol. 13(1):238-52, 1965) produces ordinary multilamellar vesicles (MLVs). Lenk et al. (U.S. Pat. Nos. 4,522,803, 5,030,453 and 5,169,637), Fountain et al. (U.S. Pat. No. 4,588,578) and Cullis et al. (U.S. Pat. No. 4,975,282) disclose methods for producing multilamellar liposomes having substantially equal interlamellar solute distribution in each of their aqueous compartments. Paphadjopoulos et al., U.S. Pat. No. 4,235,871, discloses preparation of oligolamellar liposomes by reverse phase evaporation. Each of the patents

references in this paragraph is incorporated by reference herein in their entireties for all purposes.

[1119] In one embodiment, the liposomal formulation comprises a phospholipid. In a further embodiment, the liposomal formulation comprises a sterol such as cholesterol.

[1120] In another embodiment, the liposomal formulation comprises unilamellar vesicles. Unilamellar vesicles can be produced from MLVs by a number of techniques, for example, the extrusion of Cullis *et al.* (U.S. Pat. No. 5,008,050) and Loughrey *et al.* (U.S. Pat. No. 5,059,421). Sonication and homogenization can be used to produce smaller unilamellar liposomes from larger liposomes (see, for example, Paphadjopoulos *et al.*, *Biochim. Biophys. Acta.*, 135:624-638, 1967; Deamer, U.S. Pat. No. 4,515,736; and Chapman *et al.*, *Liposome Technol.*, 1984, pp. 1-18). A review of these and other methods for producing liposomes can be found in the text *Liposomes*, Marc Ostro, ed., Marcel Dekker, Inc., New York, 1983, Chapter 1, the pertinent portions of which are incorporated herein by reference. See also Szoka, Jr. *et al.*, (1980, *Ann. Rev. Biophys. Bioeng.*, 9:467). Each of the references in this paragraph is incorporated by reference herein in their entireties for all purposes.

[1121] The term “antibody” is intended to refer broadly to any immunologic binding agent such as IgG, IgM, IgA, IgD and IgE. An antibody can be monoclonal or polyclonal, and in one embodiment, is a humanized antibody. The term “antibody” is also used to refer to any antibody-like molecule that has an antigen binding region, and includes antibody fragments such as Fab', Fab, F(ab')₂, single domain antibodies (DABs), Fv, scFv (single chain Fv), and engineering multivalent antibody fragments such as dibodies, tribodies and multibodies. The techniques for preparing and using various antibody-based constructs and fragments are well known in the art (see, e.g., *Antibodies: A Laboratory Manual*, Cold Spring Harbor Laboratory, 1988; incorporated herein by reference).

[1122] Non-limiting examples of specific drugs and classes of drugs include β -adrenoceptor antagonists (e.g., carteolol, cetamolol, betaxolol, levobunolol, metipranolol, timolol), miotics (e.g., pilocarpine, carbachol, physostigmine), sympathomimetics (e.g., adrenaline, dipivefrine), carbonic anhydrase inhibitors (e.g., acetazolamide, dorzolamide), topoisomerase inhibitors (e.g., topotecan, irinotecan, camptothecin, lamellarin D, etoposide, teniposide, doxorubicin, mitoxantrone, amsacrine), prostaglandins, anti-microbial compounds, including anti-bacterials and anti-fungals (e.g., chloramphenicol, chlortetracycline, ciprofloxacin,

framycetin, fusidic acid, gentamicin, neomycin, norfloxacin, ofloxacin, polymyxin, propamidine, tetracycline, tobramycin, quinolones), anti-viral compounds (e.g., acyclovir, cidofovir, idoxuridine, interferons), aldose reductase inhibitors, anti-inflammatory and/or anti-allergy compounds (e.g., steroidal compounds such as betamethasone, clobetasone, dexamethasone, fluorometholone, hydrocortisone, prednisolone and non-steroidal compounds such as antazoline, bromfenac, diclofenac, indomethacin, lodoxamide, saprofen, sodium cromoglycate), artificial tear/dry eye therapies, local anesthetics (e.g., amethocaine, lignocaine, oxbuprocaine, proxymetacaine), cyclosporine, diclofenac, urogastrone and growth factors such as epidermal growth factor, mydriatics and cycloplegics, mitomycin C, and collagenase inhibitors and treatments of age-related macular degeneration such as pegaptanib sodium, ranibizumab, aflibercept and bevacizumab.

[1123] In one embodiment, the drug is an integrin antagonist, a selectin antagonist, an adhesion molecule antagonist (e.g., intercellular adhesion molecule (ICAM)-1, ICAM-2, ICAM-3, platelet endothelial adhesion molecule (PCAM), vascular cell adhesion molecule (VCAM)), a leukocyte adhesion-inducing cytokine or growth factor antagonist (e.g., tumor necrosis factor- α (TNF- α), interleukin-1 β (IL-1 β), monocyte chemotatic protein-1 (MCP-1), or a vascular endothelial growth factor (VEGF)). In some embodiments, a vascular endothelial growth factor (VEGF) inhibitor is administered with one of the microneedles described herein. In some embodiments, two drugs are delivered by the methods described herein. The compounds may be administered in one formulation, or administered serially, in two separate formulations. For example, both a VEGF inhibitor and VEGF are provided. In some embodiments, the VEGF inhibitor is an antibody, for example a humanized monoclonal antibody. In further embodiments, the VEGF antibody is bevacizumab. In another embodiment, the VEGF inhibitor is ranibizumab, aflibercept or pegaptanib. In still other embodiments, the devices and methods described herein can be used to deliver one or more of the following VEGF antagonists: AL8326, 2C3 antibody, AT001 antibody, HyBEV, bevacizumab (Avastin), ANG3070, APX003 antibody, APX004 antibody, ponatinib (AP24534), BDM-E, VGX100 antibody (VGX100 CIRCADIAN), VGX200 (c-fos induced growth factor monoclonal antibody), VGX300, COSMIX, DLX903/1008 antibody, ENMD2076, Sutent (sunitinib malate), INDUS815C, R84 antibody, KD019, NM3, allogenic mesenchymal precursor cells combined with an anti-VEGF agent or antibody, MGCD265, MG516, VEGF-Receptor kinase inhibitors, MP0260, NT503, anti-DLL4/VEGF bispecific antibody, PAN90806, Palomid 529, BD0801 antibody, XV615, lucitanib (AL3810, E3810),

AMG706 (motesanib diphosphate), AAV2-sFLT01, soluble Flt1 receptor, Cediranib (Recentin), AV-951 (Tivozanib, KRN-951), Stivarga (regorafenib), Volasertib (BI6727), CEP11981, KH903, Lenvatinib (E7080), terameprocol (EM1421), ranibizumab (Lucentis), Votrient (pazopanib hydrochloride), PF00337210, PRS050, SP01 (curcumin), Carboxyamidotriazole orotate, hydroxychloroquine, linifanib (ABT869, RG3635), Iluvien (fluocinolone acetonide), ALG1001, AGN150998, DARPin MP0112, AMG386, ponatinib (AP24534), AVA101, Vargatef (nintedanib), BMS690514, KH902, golvatinib (E7050), Afinitor (everolimus), Dovitinib lactate (TKI258, CHIR258), ORA101, ORA102, Axitinib (Inlyta, AG013736), Plitidepsin (Aplidin), Lenvatinib mesylate, PTC299, aflibercept (Zaltrap, Eylea), pegaptanib sodium (Macugen, LI900015), Visudyne (verteporfin), bucillamine (Rimatil, Lamin, Brimani, Lamit, Boomiq), R3 antibody, AT001/r84 antibody, troponin (BLS0597), EG3306, vatalanib (PTK787), Bmab100, GSK2136773, Anti-VEGFR Alterase, Avila, CEP7055, CLT009, ESBA903, HuMax-VEGF antibody, GW654652, HMPL010, GEM220, HYB676, JNJ17029259, TAK593, XtendVEGF antibody, Nova21012, Nova21013, CP564959, Smart Anti-VEGF antibody, AG028262, AG13958, CVX241, SU14813, PRS055, PG501, PG545, PTI101, TG100948, ICS283, XL647, enzastaurin hydrochloride (LY317615), BC194, quinolines, COT601M06.1, COT604M06.2, MabionVEGF, SIR-Spheres coupled to anti-VEGF or VEGF-R antibody, Apatinib (YN968D1), and AL3818. In addition, delivery of a VEGF inhibitor or VEGF antagonist using the microneedle devices and methods disclosed herein may be combined with one or more agents listed herein or with other agents known in the art.

[1124] In one embodiment, delivery of a VEGF antagonist to the suprachoroidal space of the eye using the devices and methods disclosed herein is used to treat, prevent and/or ameliorate a disease or disorder selected from leukemia, relapsed/refractory leukemia, acute lymphoblastic leukemia, Acute myelogenous leukemia, relapsed or refractory acute myeloid leukemia, atopic dermatitis, recurrent or metastatic carcinoma of the urothelium, advanced urothelial carcinoma, blood disorders, myelofibrosis, brain tumor, glioblastoma, glioma, meningioma, cancer, carcinomatous meningitis (neoplastic meningitis), choroidal neovascularization (CNV), subfoveal choroidal neovascularization, chronic lymphocytic leukemia, chronic myelogenous leukemia, refractory chronic myelogenous leukemia, colon cancer, colorectal cancer, degenerative nerve diseases, Neurodegenerative diseases, diabetic macular edema, visual Impairment due to diabetic macular edema, diabetic retinopathy, dry eye syndrome (inflammation and corneal tissue damage of dry Eye), endometrial cancer, eye

diseases, ocular diseases, ocular neovascularization, eye cancer, Neurofibromatosis Type II, head and neck cancer, hematological malignancies, Kaposi's Sarcoma, Hepatocellular Carcinoma, Lung cancer, macular degeneration, age related macular degeneration, exudative age-related macular degeneration, neovascular (wet) age-related macular degeneration (AMD)), subfoveal Neovascular Age-Related macular degeneration, macular edema, macular edema associated with Branch Retinal Vein Occlusion, macular edema following retinal vein occlusion, macular edema with Retinal Vein Occlusion (RVO), multiple myeloma, relapsed or refractory multiple myeloma, multiple sclerosis, myopia, pathological myopia, neuroendocrine tumor, carcinoid tumor, neuroendocrine tumor, non-Hodgkin's Lymphoma, Diffuse Large B-Cell Lymphoma, Non-Small-Cell Lung cancer, Non-Squamous Non-Small-Cell Lung cancer, Non-small-cell-lung Adenocarcinoma, Squamous Non-Small-Cell Lung cancer, corneal graft rejection, osteoarthritis, recurrent symptomatic malignant ascites, peripheral T-cell lymphoma, androgen Independent Psoriasis, pulmonary Fibrosis, Idiopathic Pulmonary Fibrosis, respiratory diseases, retinal detachment, retinal disorders, retinitis pigmentosa, retinal vein occlusion, branch retinal vein occlusion, central retinal vein occlusion, rheumatoid arthritis, sarcoma, alveolar soft part sarcoma, soft tissue sarcoma, scleroderma/systemic sclerosis, solid tumors, refractory germ cell tumors, thyroid cancer, differentiated or medullar thyroid cancer, and West Syndrome (Infantile Spasm).

[1125] In certain embodiments, the drug delivered to the suprachoroidal space using the devices and methods disclosed herein is rapamycin (Sirolimus, Rapamune). In one embodiment, the devices (e.g., microneedle devices) and methods disclosed herein are used in conjunction with rapamycin to treat, prevent and/or ameliorate a wide range of diseases or disorders including, but not limited to: abdominal neoplasms, acquired immunodeficiency syndrome, acute coronary syndrome, acute lymphoblastic leukemia, acute myelocytic leukemia, acute non-lymphoblastic leukemia, adenocarcinoma, adenoma, adenomyoepithelioma, adnexal diseases, anaplastic astrocytoma, anaplastic large cell lymphoma, anaplastic plasmacytoma, anemia, angina pectoris, angioimmunoblastic lymphadenopathy with dysproteinemia, angiomyolipoma, arterial occlusive diseases, arteriosclerosis, astrocytoma, atherosclerosis, autoimmune diseases, B-cell lymphomas, blood coagulation disorders, blood protein disorders, bone cancer, bone marrow diseases, brain diseases, brain neoplasms, breast beoplasms, bronchial neoplasms, carcinoid syndrome, carcinoid Tumor, carcinoma, squamous cell carcinoma, central nervous system diseases, central nervous system neoplasms, choroid diseases, choroid plexus neoplasms, choroidal

neovascularization, choroiditis, chronic lymphocytic leukemia, chronic myeloid leukemia, chronic myelomonocytic leukemia, chronic myeloproliferative disorders, chronic neutrophilic leukemia, clear cell renal cell carcinoma, colonic diseases, colonic neoplasms, colorectal neoplasms, coronary artery disease, coronary disease, coronary Occlusion, coronary restenosis, coronary stenosis, coronary thrombosis, cutaneous T-cell lymphoma, diabetes mellitus, digestive system neoplasms, dry eye syndromes, ear diseases, edema, endocrine gland neoplasms, endocrine system diseases, endometrial neoplasms, Endometrial stromal tumors, Ewing's sarcoma, exanthema, eye neoplasms, fibrosis, follicular lymphoma, gastrointestinal diseases, gastrointestinal neoplasms, genital neoplasms, glioblastoma, glioma, gliosarcoma, graft vs host disease, hematologic diseases, hematologic neoplasms, hemorrhagic disorders, hemostatic disorders, Hodgkin disease, Hodgkin lymphoma, homologous wasting disease, immunoblastic lymphadenopathy, immunologic deficiency syndromes, immunoproliferative disorders, infarction, inflammation, intestinal diseases, intestinal neoplasms, ischemia, kidney cancer, kidney diseases, kidney neoplasms, leukemia, B-Cell, leukemia, lymphoid, liver cancer, liver diseases, lung diseases, lymphatic diseases, lymphoblastic lymphoma, lymphoma, macular degeneration, macular edema, melanoma, mouth neoplasms, multiple myeloma, myelodysplastic syndromes, myelofibrosis, myeloproliferative disorders, neuroectodermal tumors, neuroendocrine tumors, neuroepithelioma, neurofibroma, renal cancer, respiratory tract diseases, retinal degeneration, retinal diseases, retinal neoplasms, retinoblastoma, rhabdomyosarcoma, thoracic neoplasms, uveitis, vascular diseases, Waldenstrom Macroglobulinemia, and wet macular degeneration. In addition, delivery of rapamycin using the microneedle devices and methods disclosed herein may be combined with one or more agents listed herein or with other agents known in the art.

[1126] In one embodiment, the drug delivered to ocular tissue, for example the sclera or suprachoroidal space, using the microneedle devices and methods disclosed herein reduces, inhibits, prevents and/or ameliorates inflammation. Examples of drugs that reduce, inhibit, prevent and/or ameliorate inflammation include (but are not limited to): 19AV Agonists, 19GJ agonists, 2MD Analogs, 4SC101, 4SC102, 57-57, 5-HT2 Receptor Antagonist, 64G12, A804598, A967079, AAD2004, AB1010, AB224050, abatacept, Abegrin, Abevac, AbGn134, AbGn168, Abki, ABN912, ABR215062, ABR224050, Abrammune, Abreva, ABS15, ABS4, ABS6, ABT122, ABT325, ABT494, ABT874, ABT963, ABXIL8, ABXRB2, AC430, Accenetra, Acdeam, ACE772, Acebid, Acebloc, aceclofenac, acetaminophen,

chlorzoxazone, serrapeptase, tizanidine hydrochloride, betadex, Aceclogesic Plus, Aceclon, Acecloren, Aceclorism, acecrona, Aceffein, acemetacin, Acenac, Acenterine, Acetal-SP, ibuprofen, Acetyl-G, acetylsalicylate dl-lysine, acetylsalicylic acid, Acicot, Acifine, Acik, Aclocen, Acloflam-P, Aclomore, Aclon, A-CQ, ACS15, actarit, Actemra, Acthelea liofilizado, Actifast, Actimab-B, Actiquim, Actirin, Actis PLUS, activated leukocyte cell adhesion molecule antibody, Acular X, AD452, adalimumab, ADAMTS5 Inhibitor, ADC1001, Adco-Diclofenac, Adco-Indomethacin, Adco-Meloxicam, Adco-Naproxen, Adco-Piroxicam, Adcort, Adco-Sulindac, adenosine triphosphate disodium, AdenosineA2a Receptor Agonist, Adimod, Adinos, Adioct, Adiodol, Adipoplus, adipose derived stem and/or regenerative cells, Adizen, Adpep, Advacan, Advagraf, Advel, Adwiflam, AEB071, Aental, Afenac, Affen Plus, Afiancen, Afinitor, Aflamin, Aflazacort, Aflogen, Afloxan, AFM15, AFM16, AFM17, AFM23, Afpred-Dexa, AFX200, AG011, Agafen, aganirsen, AGI1096, Agidex, AGS010, Agudol, A-Hydrocort, AIK1, AIN457, Airtal, AIT110, AJM300, ajulemic acid, AK106, AL-24-2A1, AL4-1A1, Ala Cort, Alanz, Albumin immune-globulin, alclometasone dipropionate, ALD518, aldesleukin, Aldoderma, alefacept, alemtuzumab, Alequel, Alergolon, Alergosone, Aletraxon, Alfenac, Algason, Algin vek coat, Algioflex, Algirex, Algin Plus, alicaforsen sodium, Alin, Alinia, Aliviodol, Aliviosin, alkaline phosphatase, ALKS6931, allantoin, Allbupen, Allmol, Allochrysin, allogeneic endothelial cells, allogeneic mesenchymal precursor cells, allogeneic mesenchymal stem cells, alminoprofen, alpha 1 antitrypsin, Alpha 7 nicotinic agonists, alpha amylase, alpha chymotrypsin, alpha fetoprotein, alpha linolenic acid, Alpha-1-antitrypsin, Alpha2Beta1 Integrin Inhibitors, Alphacort, Alphafen, alpha-hexidine, alpha-trypsin, Alphinern, Alpinamed mobility omega 3, Alpoxen, AL-Rev1, Alterase, ALX0061, ALX0761, ALXN1007, ALXN1102, AM3840, AM3876, AMAB, AMAP102, Amason, Ambene, AmbezimG, amcinonide, AME133v, Amecin, Ameloteks, A-Methapred, Amevive, AMG108, AMG139, AMG162, AMG181, AMG191, AMG220, AMG623, AMG674, AMG714, AMG719, AMG729, AMG827, Amidol, amifampridine phosphate, Amifenac, Amimethacin, amiprilose hydrochloride, Amiprofen, Ammophos, Amoflam, AMP110, Ampikyy, Ampion, ampiroxicam, amtolmetin guacil, AMX256, AN6415, ANA004, ANA506, Anabu, Anacen, Anaflam, Anaflex ACI, Anaida, anakinra, Analgen Arthritis, Anapan, Anaprox, Anavan, Anax, Anco, andrographis, Aneol, Anergix, Anervax.RA, Anflene, ANG797, Anilixin, Anmerushin, Annexin 1 peptides, annexin A5, Anodyne, Ansaid, Anspirin, Antarene, Anti BST2 antibody, Anti C5a MAb, Anti ILT7 antibody, Anti VLA1 antibody, Anti-alpha11 antibody, Anti-CD4 802-2, Anti-CD86 Monoclonal Antibody,

Anti-chemokine, Anti-DC-SIGN, Anti-HMGB-1 MAb, Anti-IL-18 Mab, Anti-IL-1R MAb, Anti-IL-1R MAb, Anti-IL23 BRISTOL, Anti-inflammatory Peptides, Anti-interleukin 1Beta antibody, Anti-LIGHT antibody, Anti-LIGHT antibody, Anti-MIF Antibody, Anti-MIF Antibody, Anti-miR181a, antioxidant inflammation modulators, Antiplamine, AntiRAGE MAb, antithrombin III, Anti-TIRC-7 MAb, Anusol-HC, Anyfen, AP105, AP1089, AP1189, AP401, AP501, apazone, APD334, Apentac, APG103, Apidone, apilimod mesylate, Apitac, Apitoxin, Apizel, APN Inhibitor, apo-Azathioprine, Apo-Dexamethasone, ApoE mimetics, ApoFasL, apo-Indomethacin, apo-mefenamic, apo-methotrexate, apo-nabumetone, Apo-Napro-NA, apo-Naproxen, aponidin, apo-Phenylbutazone, apo-Piroxicam, apo-Sulin, Apo-Tenoxicam, apo-Tiaprofenic, Apranax, apremilast, apricoxib, Aprofen, Aproz, Aproxen, APX001 antibody, APX007 antibody, APY0201, AqvoDex, AQX108, AQX1125, AQX131135, AQX140, AQX150, AQX200, AQX356, AQXMN100, AQXMN106, ARA290, Arava, Arcalyst, Arcoxia, Arechin, Arflur, ARG098, ARG301, arginine aescin, arginine deiminase (pegylated), ARGX109 antibody, ARGX110, Arheuma, Aristocort, Aristospan, Ark-AP, ARN4026, Arofen, Aroff EZ, Arolef, Arotal, Arpibru, Arpimune, Arpu Shuangxin, ARQ101, Arrestin SP, Arroxx, ARRY162, ARRY371797, ARRY614, ARRY872, ART621, Artamin, Arthfree, Artho Tech, Arthrexin, Arthrispray, Arthrotec, Arthrovas, Artifit, Artigo, Artin, Artinor, Artisid, Artoflex, Artren Hipergel, Artridol, Artrilase, Artrocaptin, Artrodiet, Artrofen, Artropan, Artrosil, Artrosilene, Artrotin, Artrox, Artyflam, Arzerra, AS604850, AS605858, Asacol, ASA-Grindeks, Asazipam, Aseclo, ASF1096, ASF1096, ASK8007, ASKP1240, ASLAN003, Asmo ID, Asonep, ASP015K, ASP2408, ASP2409, Aspagin, Aspeol, Aspicam, Aspirimex, aspirin, AST120, astaxanthin, AstroCort, Aszes, AT002 antibody, AT007, AT008 antibody, AT008 antibody, AT010, AT1001, atacecept, Ataspin, Atepadene, Atgam, ATG-Fresenius, Athrofen, ATI003, atiprimod, ATL1222, ATN103, ATN192, ATR107, Atri, Atrmin, Atrosab antibody, ATX3105, AU801, auranofin, Aurobin, Auropan, Aurothio, aurotioprol, autologous adipose derived regenerative cells, Autonec, Avandia, AVE9897, AVE9940, Avelox, Avent, AVI3378, Avloquin, AVP13546, AVP13748, AVP28225, AVX002, Axcel Diclofenac, Axcel Papain, Axen, AZ17, AZ175, Azacortid, AZA-DR, Azafrine, Azamun, Azanin, Azap, Azapin, Azapren, Azaprin, Azaram, Azasan, azathioprine, AZD0275, AZD0902, AZD2315, AZD5672, AZD6703, AZD7140, AZD8309, AZD8566, AZD9056, Azet, Azintrel, azithromycin, Az-od, Azofit, Azolid, Azoran, Azulene, Azulfidine, Azulfin, B1 antagonists, Baclonet, BAF312, BAFF Inhibitor, Bages, Baily S.P., Baleston, Balsolone, baminercept alfa, bardoxolone methyl, baricitinib, Barotase, Basecam, basiliximab, Baxmune, Baxo, BAY869766, BB2827,

BCX34, BCX4208, Becfine, Beclate-C, Beclate-N, Beclolab Q, beclomethasone dipropionate, Beclorhin, Becmet-CG, Begita, Begti, belatacept, belimumab, Belosalic, Bemetson, Ben, Benevat, Benexam, Benflogin, Benisan, Benlysta, Benlysta, benorilate, Benoson, benoxaprofen, Bentol, benzydamine hydrochloride, Benzymmin, Beofenac, Berafen, Berinert, Berlofen, Bertanel, Bestamine, Bestofen, Beta Nicip, Betacort, Betacorten G, Betafoam, beta-glucan, Betalar, Beta-M, Betamed, Betamesol, betamethasone, betamethasone dipropionate, betamethasone sodium, betamethasone sodium phosphate, betamethasone valerate, Betane, Betanex, Betapanthen, Betapar, Betapred, Betason, Betasonate, Betasone, Betatrinta, Betaval, Betazon, Betazone, Betesil, Betnecort, Betnesol, Betnovate, Bextra, BFPC13, BFPC18, BFPC21, BFPT6864, BG12, BG9924, BI695500, BI695501, BIA12, Big-Joint-D, BIIB023 antibody, Bi-ksikam, Bingo, BioBee, Bio-Cartilage, Bio-C-Sinkki, Biodexone, Biofenac, Bioreucam, Biosone, Biosporin, BIRB796, Bitnoval, Bitvio, Bivigam, BKT140, BKTP46, BL2030, BL3030, BL4020, BL6040, BL7060, BLI1300, blisibimod, Blokium B12, Blokium Gestic, Blokium, BMS066, BMS345541, BMS470539, BMS561392, BMS566419, BMS582949, BMS587101, BMS817399, BMS936557, BMS945429, BMS-A, BN006, BN007, BNP166, Bonacort, Bonas, bone marrow stromal cell antigen 2 antibody, Bonflex, Bonifen, Boomiq, Borbit, Bosong, BR02001, BR3-FC, Bradykinin B1 Receptor Antagonist, Bredinin, Brexecam, Brexin, Brexodin, briakinumab, Brimani, briobacept, Bristaflam, Britten, Broben, brodalumab, Broen-C, bromelains, Bromelin, Bronax, Bropain, Brosiral, Bruace, Brufadol, Brufen, Brugel, Brukil, Brusil, BT061, BTI9, BTK kinase inhibitors, BTT1023 antibody, BTT1507, bucillamine, Bucillate, Bucu Reigis, bucolome, Budenofalk, budesonide, Budex, Bufect, Bufencon, Bukwang Ketoprofen, Bunide, Bunofen, Busilvex, busulfan, Busulfex, Busulipo, Butartrol, Butarut B12, Butasona, Butazolidin, Butesone, Butidiona, BVX10, BXL628, BYM338, B-Zone, C1 esterase inhibitor, C243, c4462, c5997, C5aQb, c7198, c9101, C9709, c9787, CAB101, cadherin 11 antibody, caerulomycin A, CAL263, Calcort, Calmatel, CAM3001, Camelid Antibodies, Camlox, Camola, Campath, Camrox, Camtenam, canakinumab, candida albicans antigen, Candin, cannabidiol, CAP1.1, CAP1.2, CAP2.1, CAP2.2, CAP3.1, CAP3.2, Careram, Carimune, Cariodent, Cartifix, CartiJoint, Cartilago, Cartisafe-DN, Cartishine, Cartivit, Cartril-S, Carudol, CaspaCIDE, CaspaCIDE, Casyn, CAT1004, CAT1902, CAT2200, Cataflam, Cathepsin S inhibitor, Catlep, CB0114, CB2 agonist, CC0478765, CC10004, CC10015, CC1088, CC11050, CC13097, CC15965, CC16057, CC220, CC292, CC401, CC5048, CC509, CC7085, CC930, CCR1 Antagonist, CCR6 Inhibitor, CCR7 Antagonist, CCRL2 antagonist, CCX025, CCX354, CCX634, CD

Diclofenac, CD102, CD103 Antibody, CD103 Antibody, CD137 antibody, CD16 antibody, CD18 antibody, CD19 antibody, CD1d Antibody, CD20 antibody, CD200Fc, CD209 antibody, CD24, CD3 antibody, CD30 antibody, CD32A antibody, CD32B antibody, CD4 antibody, CD40 ligand, CD44 antibody, CD64 antibody, CDC839, CDC998, CDIM4, CDIM9, CDK9-Inhibitor, CDP146, CDP323, CDP484, CDP6038, CDP870, CDX1135, CDX301, CE224535, Ceanel, Cebedex, Cebutid, Ceclonac, Ceex, CEL2000, Celact, Celbexx, Celcox, Celebiox, Celebrex, Celebrin, Celecox, celecoxib, Celedol, Celestone, Celevex, Celex, CELG4, Cell adhesion molecule antagonists, CellCept, Cellmune, Celosti, Celoxib, Celprot, Celudex, cenicriviroc mesylate, cenplacel-1, CEP11004, CEP37247, CEP37248, Cephyr, Cefprofen, Certican, certolizumab pegol, Cetofenid, Cetoprofeno, cetylpyridinium chloride, CF101, CF402, CF502, CG57008, CGEN15001, CGEN15021, CGEN15051, CGEN15091, CGEN25017, CGEN25068, CGEN40, CGEN54, CGEN768, CGEN855, CGI1746, CGI560, CGI676, Cgtx-Peptides, CH1504, CH4051, CH4446, chaperonin 10, chemokine C-C motif ligand 2, chemokine C-C motif ligand 2 antibody, chemokine C-C motif ligand 5 antibody, chemokine C-C motif receptor 2 antibody, chemokine C-C motif receptor 4 antibody, chemokine C-X-C motif ligand 10 antibody, chemokine C-X-C motif ligand 12 aptamer, Chemotaxis Inhibitor, Chillmetacin, chitinase 3-like 1, Chlocodemin, Chloquin, chlorhexidine gluconate, chloroquine phosphate, choline magnesium trisalicylate, chondroitin sulfate, Chondrocart, CHR3620, CHR4432, CHR5154, Chrysalin, Chuanxinlian, Chymapra, Chymotase, chymotrypsin, Chytmutip, CI202, CI302, Cicloderm-C, Ciclopren, Cicporal, Cilamin, Cimzia, cinchophen, cinmetacin, cinnoxicam, Cinoderm, Cinolone-S, Cinryze, Cipcorlin, cipemastat, Cipol-N, Cipridanol, Cipzen, Citax F, Citogan, Citoken T, Civamide, CJ042794, CJ14877, c-Kit monoclonal antibody, cladribine, Clafen, Clanza, Claversal, clazakizumab, Clearoid, Clease, Clevegen, Clevian, Clidol, Clindac, Clinoril, Cliptol, Clobenate, Clobequad, clobetasol butyrate, clobetasol propionate, Clodol, clofarabine, Clofen, Clofenal LP, Clolar, Clonac, Clongamma, clonixin lysine, Clotasoc, Clovacort, Clovana, Cloxin, CLT001, CLT008, C-MAF Inhibitor, CMPX1023, Cnac, CNDO201, CNI1493, CNTO136, CNTO148, CNTO1959, Cobefen, CoBenCoDerm, Cobix, Cofenac, Cofenac, COG241, COL179, colchicine, Colchicum Dispert, Colchimax, Colcibra, Coledes A, Colesol, Colifoam, Colirest, collagen, type V, Comcort, complement component (3b/4b) receptor 1, Complement Component C1s Inhibitors, complement component C3, complement factor 5a receptor antibody, complement factor 5a receptor antibody, complement factor D antibody, Condrosulf, Condrotec, Condrothin, conestat alfa, connective tissue growth factor antibody, Coolpan, Copaxone, Copiron, Cordefla, Corhydron,

Cort S, Cortan, Cortate, Cort-Dome, Cortecetine, Cortef, Corteroid, Corticap, Corticas, Cortic-DS, corticotropin, Cortiderm, Cortidex, Cortiflam, Cortinet M, Cortinil, Cortipyren B, Cortiran, Cortis, Cortisolu, cortisone acetate, Cortival, Cortone acetate, Cortopin, Cortoral, Cortril, Cortypiren, Cosamine, Cosone, cosyntropin, COT Kinase Inhibitor, Cotilam, Cotrisone, Cotson, Covox, Cox B, COX-2/5-LO Inhibitors, Coxeton, Coxflam, Coxicam, Coxitor, Coxtral, Coxypar, CP195543, CP412245, CP424174, CP461, CP629933, CP690550, CP751871, CPSI2364, C-quin, CR039, CR074, CR106, CRA102, CRAC channel inhibitor, CRACM Ion Channel Inhibitor, Cratisone, CRB15, CRC4273, CRC4342, C-reactive protein 2-methoxyethyl phosphorothioate oligonucleotide, CreaVax-RA, CRH modulators, critic-aid, Crocam, Crohnsvax, Cromoglycic acid, cromolyn sodium, Cronocorteroid, Cronodicasone, CRTX803, CRx119, CRx139, CRx150, CS502, CS670, CS706, CSF1R Kinase Inhibitors, CSL324, CSL718, CSL742, CT112, CT1501R, CT200, CT2008, CT2009, CT3, CT335, CT340, CT5357, CT637, CTP05, CTP10, CT-P13, CTP17, Cuprenil, Cuprimine, Cuprindo, Cupripen, Curaquin, Cutfen, CWF0808, CWP271, CX1020, CX1030, CX1040, CX5011, Cx611, Cx621, Cx911, CXC chemokine receptor 4 antibody, CXCL13 antibodies, CXCR3 antagonists, CXCR4 antagonist, Cyathus 1104 B, Cyclo-2, Cyclocort, cyclooxygenase-2 inhibitor, cyclophosphamide, Cyclorine, Cyclosporin A Prodrug, Cyclosporin analogue A, cyclosporine, Cyrevia, Cyrin CLARIS, CYT007TNFQb, CYT013IL1bQb, CYT015IL17Qb, CYT020TNFQb, CYT107, CYT387, CYT99007, cytokine inhibitors, Cytopan, Cytoreg, CZC24832, D1927, D9421C, daclizumab, danazol, Danilase, Dantes, Danzen, dapsone, Dase-D, Daypro, Daypro Alta, Dayrun, Dazen, DB295, DBTP2, D-Cort, DD1, DD3, DE096, DE098, Debio0406, Debio0512, Debio0615, Debio0618, Debio1036, Decaderm, Decadrane, Decadron, Decadronal, Decalon, Decan, Decason, Decdan, Decilone, Declophen, Decopen, Decorex, Decorten, Dedema, Dedron, Deexa, Defcort, De-flam, Deflamat, Deflan, Deflanil, Deflaren, Deflaz, deflazacort, Defnac, Defnalone, Defnil, Defosalic, Defsure, Defza, Dehydrocortison, Dekort, Delagil, delcasertib, delmitide, Delphicort, Deltacorsolone, Deltacortril, Deltafluorene, Deltasolone, Deltasone, Deltastab, Deltonin, Demarin, Demisone, Denebola, denileukin diftitox, denosumab, Denzo, Depocortin, Depo-medrol, Depomethotrexate, Depopred, Deposet, Depyrin, Derinase, Dermol, Dermolar, Dermonate, Dermosone, Dersone, Desketo, desonide, desoxycorticosterone acetate, Deswon, Dexa, Dexabene, Dexacip, Dexacort, Dexacortisone, Dexacotisil, Dexadic, Dexadrin, Dexadron, Dexafar, Dexahil, Dexalab, Dexalaf, Dexalet, Dexalgen, Dexallion, Dexalocal, Dexalone, Dexa-M, Dexamecortin, Dexamed, Dexamedis, Dexameral, Dexameta, Dexamethasone, dexamethasone acetate, dexamethasone palmitate, dexamethasone phosphate, dexamethasone

sodium metasulfobenzoate, dexamethasone sodium phosphate, Dexamine, Dexapanthen, Dexa-S, Dexason, Dexatab, Dexatopic, Dexaval, Dexaven, Dexazolidin, Dexazona, Dexazone, Dexcor, Dexibu, dexibuprofen, Dexico, Dexifen, Deximune, dexketoprofen, dexketoprofen trometamol, Dexmark, Dexomet, Dexon I, Dexonalin, Dexonex, Dexony, Dexoptifen, Dexpin, Dextan-Plus, dextran sulfate, Dezacor, Dfz, diacerein, Diannexin, Diastone, Dicarol, Dicasone, Dicknol, Diclo, Diclobon, Diclobonse, Diclobonzox, Diclofast, Diclofen, diclofenac, diclofenac beta-dimethylaminoethanol, diclofenac deanol, diclofenac diethylamine, diclofenac epolamine, diclofenac potassium, diclofenac resinate, diclofenac sodium, Diclogen AGIO, Diclogen Plus, Diclokim, Diclomed, Diclo-NA, Diclonac, Dicloramin, Dicloran, Dicloreum, Diclorism, Diclotec, Diclovit, Diclowal, Diclozem, Dico P, Dicofen, Dicoliv, Dicorsona, Dicron, Dicser, Difena, Diffutab, diflunisal, dilmapiomod, Dilora, dimethyl sulfone, Dinac, D-Indomethacin, Dioxaflex Protect, Dipagesic, Dipenopen, Dipexin, Dipro AS, Diprobeta, Diprobetasone, Diproklenat, Dipromet, Dipronova, Diprosone, Diprovate, Diproxen, Disarmin, Diser, Disopain, Dispain, Dispercarn, Distamine, Dizox, DLT303, DLT404, DM199, DM99, DMI9523, dnaJP1, DNX02070, DNX04042, DNX2000, DNX4000, docosanol, Docz-6, Dolamide, Dolaren, Dolchis, Dolex, Dolflam, Dolfre, Dolgit, Dolmax, Dolmina, Dolo Ketazon, Dolobest, Dolobid, Doloc, Dolocarn, Dolocartigen, Dolofit, Dolokind, Dolomed, Dolonac, Dolonex, Dolotren, Dolozen, Dolquine, Dom0100, Dom0400, Dom0800, Domet, Dometon, Dominadol, Dongipap, Donica, Dontisanin, doramapiomod, Dorixina Relax, Dormelox, Dorzine Plus, Doxatar, Doxtran, DP NEC, DP4577, DP50, DP6221, D-Penamaine, DPIV/APN Inhibitors, DR1 Inhibitors, DR4 Inhibitors, DRA161, DRA162, Drenex, DRF4848, DRL15725, Drossadin, DSP, Duexis, Duo-Decadron, Duoflex, Duonase, DV1079, DV1179, DWJ425, DWP422, Dymol, DYN15, Dynapar, Dysmen, E5090, E6070, Easy Dayz, Ebetrexat, EBI007, EC0286, EC0565, EC0746, Ecax, echinacea purpurea extract, EC-Naprosyn, Econac, Ecosprin 300, Ecosprin 300, Ecradoxan, eculizumab, Edecarn, efalizumab, Efcortisol, Effigel, Eflagen, Efridol, EGFR Antibody, EGS21, eIF5A1 siRNA, Ekarzin, elafin, Eldoflam, Elidel, Eliflam, Elisone, Elmes, Elmetacin, ELND001, ELND004, elocalcitol, Elocorn, elsibucol, Emanzen, Emcort, Emifen, Emifenac, emorfazone, Empynase, emricasan, Emtor, Enable, Enbrel, Enceid, EncorStat, Encortolon, Encorton, Endase, Endogesic, Endoxan, Enkorten, Ensera, Entocort, Enzylan, Epanova, Eparang, Epatec, Epicotil, epidermal growth factor receptor 2 antibody, epidermal growth factor receptor antibody, Epidixone, Epidron, Epiklin, EPPA1, epratuzumab, EquiO, Erac, Erazon, ERB041, ERB196, Erdon, EryDex, escherichia coli enterotoxin B subunit, Escin, E-Selectin Antagonists, Esfenac, ESN603, esonarimod,

Esprofen, estetrol, Estopein, Estrogen Receptor beta agonist, etanercept, etaracizumab, ETC001, ethanol propolis extract, ETI511, etiprednol dicloacetate, Etodin, Etodine, Etodol, etodolac, Etody, etofenamate, Etol Fort, Etolac, Etopin, etoricoxib, Etorix, Etosafe, Etova, Etozox, Etura, Eucob, Eufans, eukaryotic translation initiation factor 5A oligonucleotide, Eunac, Eurocox, Eurogesic, everolimus, Evinopon, EVT401, Exaflam, EXEL9953, Exicort, Expen, Extra Feverlet, Extrapan, Extrauma, Exudase, F16, F991, Falcam, Falcol, Falzy, Farbovil, Farcomethacin, Farnerate, Farnezone, Farnezone, Farotrin, fas antibody, Fastflam, FasTRACK, Fastum, Fauldmetro, FcgammaRIA antibody, FE301, Febrofen, Febrofid, felbinac, Feldene, Feldex, Feloran, Felxicam, Fenac, Fenacop, Fenadol, Fenaflan, Fenamic, Fenaren, Fenaton, Fenbid, fenbufen, Fengshi Gutong, Fenicort, Fenopine, fenoprofen calcium, Fenopron, Fenris, Fensupp, Fenxicam, fepradinol, Ferovisc, Feverlet, fezakinumab, FG3019, FHT401, FHTCT4, FID114657, figitumumab, Filexi, filgrastim, Fillase, Final, Findoxin, fingolimod hydrochloride, firategrast, Firdapse, Fisiodar, Fivasa, FK778, Flacocto, Fladalgin, Flagon, Flamar, Flamcid, Flamfort, Flamide, Flaminase, Flamirex Gesic, Flamid, Flanzen, Flaren, Flaren, Flash Act, Flavonoid Anti-inflammatory Molecule, Flebogamma DIF, Flenac, Flex, Flexafen 400, Flexi, Flexidol, Flexium, Flexon, Flexono, Flogene, Flogiatriin B12, Flogomin, Flogoral, Flogosan, Flogoter, Flo-Pred, Flosteron, Flotrip Forte, Flt3 inhibitors, fluasterone, Flucam, Flucinar, fludrocortisone acetate, flufenamate aluminum, flumethasone, Flumidon, flunixin, fluocinolone, fluocinolone acetonide, fluocinonide, fluocortolone, Fluonid, fluorometholone, Flur, flurbiprofen, Fluribec, Flurometholone, Flutal, fluticasone, fluticasone propionate, Flutizone, Fluzone, FM101 antibody, fms-related tyrosine kinase 1 antibody, Folitrax, fontolizumab, formic acid, Fortecortin, Fospeg, fostamatinib disodium, FP1069, FP13XX, FPA008, FPA031, FPT025, FR104, FR167653, Framebin, Frime, Froben, Frolix, FROUNT Inhibitors, Fubifen PAP, Fucole ibuprofen, Fulamotol, Fulpen, Fungifin, Furotalgin, fusidate sodium, FX002, FX141L, FX201, FX300, FX87L, Galectin modulators, gallium maltolate, Gamimune N, Gammagard, Gamma-I.V., GammaQuin, Gamma-Venin, Gamunex, Garzen, Gaspirin, Gattex, GBR500, GBR500 antibody, GBT009, G-CSF, GED0301, GED0414, Gefenec, Gelofen, Genepril, Gengraf, Genimmune, Geniquin, Genotropin, Genz29155, Gerbin, Gerbin, gevokizumab, GF01564600, Gilenia, Gilenya, givinostat, GL0050, GL2045, glatiramer acetate, Globulin, Glortho Forte, Glovalox, Glovenin-I, GLPG0259, GLPG0555, GLPG0634, GLPG0778, GLPG0974, Gluco, Glucocerin, glucosamine, glucosamine hydrochloride, glucosamine sulfate, Glucotin, Gludex, Glutilage, GLY079, GLY145, Glycanic, Glycefort up, Glygesic, Glysopep, GMCSF Antibody, GMI1010, GMI1011, GMI1043, GMR321, GN4001, Goanna Salve, Goflex, gold

sodium thiomalate, golimumab, GP2013, GPCR modulator, GPR15 Antagonist, GPR183 antagonist, GPR32 antagonist, GPR83 antagonist, G-protein Coupled Receptor Antagonists, Graceptor, Graftac, granulocyte colony-stimulating factor antibody, granulocyte-macrophage colony-stimulating factor antibody, Gravx, GRC4039, Grelyse, GS101, GS9973, GSC100, GSK1605786, GSK1827771, GSK2136525, GSK2941266, GSK315234, GSK681323, GT146, GT442, Gucixiaotong, Gufisera, Gupisone, gusperimus hydrochloride, GW274150, GW3333, GW406381, GW856553, GWB78, GXP04, Gynestrel, Haloart, halopredone acetate, Haloxin, HANALL, Hanall Soludacortin, Havisco, Hawon Bucillamin, HB802, HC31496, HCQ 200, HD104, HD203, HD205, HDAC inhibitor, HE2500, HE3177, HE3413, Hecoria, Hectomitacin, Hefasolon, Helen, Helenil, HemaMax, Hematom, hematopoietic stem cells, Hematrol, Hemner, Hemril, heparinoid, Heptax, HER2 Antibody, Herponil, hESC Derived Dendritic Cells, hESC Derived Hematopoietic stem cells, Hespercorbin, Hexacorton, Hexadrol, hexetidine, Hexoderm, Hexoderm Salic, HF0220, HF1020, HFT-401, hG-CSFR ED Fc, Hiberna, high mobility group box 1 antibody, Hiloneed, Hinocam, hirudin, Hirudoid, Hison, Histamine H4 Receptor Antagonist, Hitenercept, Hizentra, HL036, HL161, HMPL001, HMPL004, HMPL004, HMPL011, HMPL342, HMPL692, honey bee venom, Hongqiang, Hotemin, HPH116, HTI101, HuCAL Antibody, Human adipose mesenchymal stem cells, anti-MHC class II monoclonal antibody, Human Immunoglobulin, Human Placenta Tissue Hydrolysate, HuMaxCD4, HuMax-TAC, Humetone, Humicade, Humira, Huons Betamethasone sodium phosphate, Huons dexamethasone sodium phosphate, Huons Piroxicam, Huons Talniflumate, Hurofen, Huruma, Huvap, HuZAF, HX02, Hyalogel, hyaluronate sodium, hyaluronic acid, hyaluronidase, Hyaron, Hycocin, Hycort, Hy-Cortisone, hydrocortisone, hydrocortisone acetate, hydrocortisone butyrate, hydrocortisone hemisuccinate, hydrocortisone sodium phosphate, hydrocortisone sodium succinate, Hydrocortistab, Hydrocortone, Hydrolin, Hydroquine, Hydro-Rx, Hydrosone HIKMA, hydroxychloroquine, hydroxychloroquine sulfate, Hylase Dessau, HyMEX, Hypen, HyQ, Hysonate, HZN602, I.M.75, IAP Inhibitors, Ibalgin, Ibalgin, Ibex, ibrutinib, IBsolvmIR, Ibu, Ibucon, Ibudolor, Ibufen, Ibuflam, Ibuflex, Ibugesic, Ibu-Hepa, Ibukim, Ibumal, Ibunal, Ibupental, Ibupril, Ibuprof, ibuprofen, Ibuscent, Ibusoft, Ibusuki Penjeong, Ibususpen, Ibutard, Ibutop, Ibutop, Ibutrex, IC487892, ichthammol, ICRAC Blocker, IDEC131, IDECCE9.1, Ides, Idicin, Idizone, IDN6556, Idomethine, IDR1, Idyl SR, Ifen, iguratimod, IK6002, IKK-beta inhibitor, IL17 Antagonist, IL-17 Inhibitor, IL-17RC, IL18, IL1Hy1, IL1R1, IL-23 Adnectin, IL23 Inhibitor, IL23 Receptor Antagonist, IL-31 mAb, IL-6 Inhibitor, IL6Qb, Ilacox, Ilaris, ilodecakin, ILV094, ILV095, Imaxetil, IMD0560, IMD2560,

Imesel Plus, Iminorol, Immodin, IMMU103, IMMU106, Immucept, Immufine, Immunex Syrup, immunoglobulin, immunoglobulin G, Immunoprin, ImmunoRel, Immurin, IMO8400, IMP731 antibody, Implanta, Imunocell, Imuran, Imurek, Imusafe, Imusporin, Imutrex, IN0701, Inal, INCB039110, INCB18424, INCB28050, INCB3284, INCB3344, Indexon, Indic, Indo, Indo-A, Indobid, Indo-Bros, Indocaf, Indocarsil, Indocid, Indocin, Indomehotpas, Indomen, Indomet, Indometacin, indomethacin, Indomethasone, Indometin, Indomin, Indopal, Indoron, Indotroxin, INDUS830, INDUS83030, Infladase, Inflammac, Inflammasome inhibitor, Inflavis, Influxen, Inflectra, infliximab, Ingalipt, Inicox dp, Inmecin, Inmunoartro, Innamit, InnoD06006, INO7997, Inocin, Inoten, Inovon, Inpra, Inside Pap, Insider-P, Instacyl, Instracool, Intafenac, Intaflam, Inteban, Inteban Spansule, integrin, alpha 1 antibody, integrin, alpha 2 antibody, Intenurse, interferon alfa, interferon beta-1a, interferon gamma, interferon gamma antibody, Interking, interleukin 1 Hy1, interleukin 1 antibody, interleukin 1 receptor antibody, interleukin 1, beta antibody, interleukin 10, interleukin 10 antibody, interleukin 12, interleukin 12 antibody, interleukin 13 antibody, interleukin 15 antibody, interleukin 17 antibody, interleukin 17 receptor C, interleukin 18, interleukin 18 binding protein, interleukin 18 antibody, interleukin 2 receptor, alpha antibody, interleukin 20 antibody, Interleukin 21 mAb, interleukin 23 aptamer, interleukin 31 antibody, interleukin 34, Interleukin 6 Inhibitor, interleukin 6 antibody, interleukin 6 receptor antibody, interleukin 7, interleukin 7 receptor antibody, interleukin 8, interleukin 8 antibody, interleukin-18 antibody, Intidrol, Intradex, Intragam P, Intragesic, Intraglobin F, Intratect, Inzel, Iomab B, IOR-T3, IP751, IPH2201, IPH2301, IPH24, IPH33, IPI145, Ipocort, IPP201007, I-Profen, Iprox, Ipson, Iputon, IRAK4 Inhibitor, Iremod, Irtonpyson, IRX3, IRX5183, ISA247, ISIS104838, ISIS2302, ISISCRPRx, Ismafron, IsoQC inhibitor, Isox, ITF2357, Iveegam EN, Ivepred, IVIG-SN, IW001, Izilox, J607Y, J775Y, JAK Inhibitor, JAK3 inhibitor, JAK3 kinase inhibitor, JI3292, JI4135, Jinan Lida, JNJ10329670, JNJ18003414, JNJ26528398, JNJ27390467, JNJ28838017, JNJ31001958, JNJ38518168, JNJ39758979, JNJ40346527, JNJ7777120, JNT-Plus, Joflam, Joint Glucosamin, Jointec, Jointstem, Joinup, JPE1375, JSM10292, JSM7717, JSM8757, JTE051, JTE052, JTE522, JTE607, Jusgo, K412, K832, Kaflam, KAHR101, KAHR102, KAI9803, Kalymin, Kam Predsol, Kameton, KANAb071, Kappaproct, KAR2581, KAR3000, KAR3166, KAR4000, KAR4139, KAR4141, KB002, KB003, KD7332, KE298, keliximab, Kemanat, Kemrox, Kenacort, Kenalog, Kenaxir, Kenketsu Venoglobulin-IH, Keplat, Ketalgipan, Keto Pine, Keto, Ketobos, Ketofan, Ketofen, Ketolgan, Ketonal, Ketoplus Kata Plasma, ketoprofen, Ketores, Ketorin, ketorolac, ketorolac tromethamine, Ketoselect, Ketotop, Ketovail, Ketricin, Ketroc, Ketum, Keyi, Keyven,

KF24345, K-Fenac, K-Fenak, K-Gesic, Kifadene, Kilcort, Kildrol, KIM127, Kimotab, Kinase Inhibitor 4SC, Kinase N, Kincort, Kindorase, Kineret, Kineto, Kitadol, Kitex, Kitolac, KLLK1 Inhibitor, Klofen-L, Klotaren, KLS-40or, KLS-40ra, KM277, Knavon, Kodolo orabase, Kohakusanin, Koide, Koidexa, Kolbet, Konac, Kondro, Kondromin, Konshien, Kontab, Kordexa, Kosa, Kotase, KPE06001, KRP107, KRP203, KRX211, KRX252, KSB302, K-Sep, Kv 1.3 Blocker, Kv1.3 4SC, Kv1.3 inhibitor, KVK702, Kynol, L156602, Labizone, Labohydro, Labopen, Lacoza, Lamin, Lamit, Lanfetil, laquinimod, larazotide acetate, LAS186323, LAS187247, LAS41002, Laticort, LBEC0101, LCP3301, LCP-Siro, LCP-Tacro, LCsA, LDP392, Leap-S, Ledercort, Lederfen, Lederlon, Lederspan, Lefenine, leflunomide, Leflux, Lefno, Lefra, Leftose, Lefumide, Lefunodin, Lefva, lenalidomide, lenercept, LentiRA, LEO15520, Leodase, Leukine, Leukocyte function-associated antigen-1 antagonist, leukocyte immunoglobulin-like receptor, subfamily A, member 4 antibody, Leukothera, leuprolide acetate, levalbuterol, levomenthol, LFA-1 Antagonist, LFA451, LFA703, LFA878, LG106, LG267 Inhibitors, LG688 Inhibitors, LGD5552, Li Life, LidaMantle, Lidex, lidocaine, lidocaine hydrochloride, Lignocaine hydrochloride, LIM0723, LIM5310, Limethason, Limus, Limustin, Lindac, Linfonex, Linola acute, Lipey, lisofylline, Listran, Liver X Receptor modulator, Lizak, LJP1207, LJP920, Lobafen, Lobu, Locaflu, Localyn, Locaseptil-Neo, Locpren, Lodine, Lodotra, Lofedic, Loflam, Lofnac, Lolcam, Lonac, lonazolac calcium, Loprofen, Loracort, Lorcam, Lorfenamin, Lorinden Lotio, Lorncrat, lornoxicam, Lorox, losmapimod, loteprednol etabonate, Loteprednol, Lotirac, Low Molecular Ganoderma Lucidum Polysaccharide, Loxafen, Loxfenine, Loxicam, Loxofen, Loxonal, Loxonin, loxoprofen sodium, Loxoron, LP183A1, LP183A2, LP204A1, LPCN1019, LT1942, LT1964, LTNS101, LTNS103, LTNS106, LTNS108, LTS1115, LTZMP001, Lubor, lumiracoxib, Lumitect, LX2311, LX2931, LX2932, LY2127399, LY2189102, LY2439821, LY294002, LY3009104, LY309887, LY333013, lymphocyte activation gene 3 antibody, Lymphoglobuline, Lyser, lysine aspirin, Lysobact, Lysoflam, Lysozyme hydrochloride, M3000, M834, M923, mAb hG-CSF, MABP1, macrophage migration inhibitory factor antibody, Maitongna, Majamil prolongatum, major histocompatibility complex class II DR antibody, major histocompatibility complex class II antibody, Malidens, Malival, mannan-binding lectin, mannan-binding lectin-associated serine protease-2 antibody, MapKap Kinase 2 Inhibitor, maraviroc, Marlex, masitinib, Maso, MASP2 antibody, MAT304, Matrix Metalloprotease Inhibitor, mavrilimumab, Maxiflam, Maxilase, Maximus, Maxisona, Maxius, Maxpro, Maxrel, Maxsulid, Maxy12, Maxy30, MAXY4, Maxy735, Maxy740, Mayfenamic, MB11040, MBPY003b, MCAF5352A,

McCam, McRofy, MCS18, MD707, MDAM, MDcort, MDR06155, MDT012, Mebicam, Mebuton, meclofenamate sodium, Meclophen, Mecox, Medacomb, Medafen, Medamol, Medesone, MEDI2070, MEDI5117, MEDI541, MEDI552, MEDI571, Medicox, Medifen, Medisolu, Medixon, Mednisol, Medrol, Medrolon, medroxyprogesterone acetate, Mefalgin, mefenamic acid, Mefenix, Mefentan, Meflen, Mefnetra forte, Meftagesic-DT, Meftal, Megakaryocyte Growth and Development Factor, Megaspas, Megaster, megestrol acetate, Meite, Meksun, Melbrex, Melcam, Melcam, Melflam, Melic, Melica, Melix, Melocam, Melocox, Mel-One, Meloprol, Melosteral, Melox, Meloxan, Meloxcam, Meloxic, Meloxicam, Meloxifen, Meloxin, Meloxiv, Melpred, Melpros, Melurjin, Menamin, Menisone, Menthomketo, Menthoneurin, Mentocin, Mepa, Mepharen, meprednisone, Mepresso, Mepsolone, mercaptopurine, Mervan, Mesadoron, mesalamine, Mesasal, Mesatec, Mesenchymal Precursor Cells, mesenchymal stem cell, Mesipol, Mesren, Mesulan, Mesulid, Metacin, Metadaxan, Metaflex, Metalcaptase, metalloenzyme inhibitors, Metapred, Metax, Metaz, Meted, Metedic, Methacin, Methaderm, Methasone, Methotrax, methotrexate, methotrexate sodium, Methpred, Methyl prednisolone acetate, methyl salicylate, methyl sulphonyl methane, Methylon, Methylpred, methylprednisolone, methylprednisolone acetate, methylprednisolone sodium succinate, methylprednisolone succinate, Methylprednisolone, Methysol, Metindol, Metoart, Metoject, Metolate, Metoral, Metosyn, Metotab, Metracin, Metrex, metronidazole, Metypred, Mevamox, Mevedal, Mevilox, Mevin SR, Mexilal, Mexpharm, Mext, Mextran, MF280, M-FasL, MHC class II beta chain peptide, Micar, Miclofen, Miclofenac, Micofenolato Mofetil, Micosone, Microdase, microRNA 181a-2 oligonucleotide, MIF Inhibitors, MIFQb, MIKA-Ketoprofen, Mikametan, milodistim, Miltax, Minafen, Minalfen, Minalfene, Minesulin, Minocort, Mioflex, Miolox, Miprofen, Miridacin, Mirloks, Misoclo, Misofenac, MISTB03, MISTB04, Mitilor, mizoribine, MK0359, MK0812, MK0873, MK2 Inhibitors, MK50, MK8457, MK8808, MKC204, MLN0002, MLN0415, MLN1202, MLN273, MLN3126, MLN3701, MLN3897, MLNM002, MM093, MM7XX, MN8001, Mobic, Mobicam, Mobicox, Mobifen Plus, Mobilat, Mobitil, Mocox, Modigraf, Modrasone, Modulin, Mofecept, Mofetyl, mofezolac sodium, Mofilet, Molace, molgramostim, Molslide, Momekin, Momen Gele, Moment 100, Momesone, Momesun, Mometamed, mometasone, mometasone furoate, Monimate, monosodium alpha-luminol, Mopik, MOR103, MOR104, MOR105, MOR208 antibody, MORAb022, Moricam, morniflumate, Mosuolit, Motalal, Movaxin, Mover, Movex, Movix, Movoxicam, Mox Forte, Moxen, moxifloxacin hydrochloride, Mozobil, MP, MP0210, MP0270, MP1000, MP1031, MP196, MP435, MPA, mPGES-1 inhibitor, MPSS, MRX7EAT, MSL, MT203, MT204,

mTOR Inhibitor, MTRX1011A, Mucolase, Multicort, MultiStem, muramidase, muramidase, muramidase hydrochloride, muromonab-CD3, Muslax, Muspinil, Mutaze, Muvera, MX68, Mycept, Mycozell, Mycocept, Mycofenolatmofetil Actavis, Mycofet, Mycofit, Mycolate, Mycoldosa, Mycomun, Myconol, mycophenolate mofetil, mycophenolate sodium, mycophenolic acid, Mycotil, myeloid progenitor cells, Myfenax, Myfetil, Myfortic, Mygraft, Myochrysin, Myocrisin, Myprodol, Mysone, nab-Cyclosporine, Nabentac, nabiximols, Nabton, Nabuco, Nabucox, Nabuflam, Nabumet, nabumetone, Nabuton, Nac Plus, Nacta, Nacton, Nadium, Naklofen SR, NAL1207, NAL1216, NAL1219, NAL1268, NAL8202, Nalfon, Nalgessin S, namilumab, Namsafe, nandrolone, Nanocort, Nanogam, Nanosomal Tacrolimus, Napageln, Napilac, Naprelan, Napro, Naprodil, Napronax, Napropal, Naproson, Naprosyn, Naproval, Naprox, naproxen, naproxen sodium, Naproxin, Naprozen, Narbon, Narexsin, Naril, Nasida, natalizumab, Naxdom, Naxen, Naxin, Nazovel, NC2300, ND07, NDC01352, Nebumetone, NecLipGCSF, Necsulide, Necsunim, Nelsid-S, Neo Clobenate, Neo Swiflox FC, Neocoflan, Neo-Drol, Neo-Eblimon, Neo-Hydro, Neoplanta, Neoprine, Neopreol, Neoprox, Neoral, Neotrexate, Neozen, Nepra, Nestacort, Neumega, Neupogen, Neuprex, Neurofenac, Neurogesic, Neurolab, Neuroteradol, Neuroxicam, Neutalin, neutrazumab, Neuzym, New Panazox, Newfenstop, NewGam, Newmafen, Newmatal, Newsicam, NEX1285, sFcRIIB, Nextomab, NF-kappaB Inhibitor, NF-kB inhibitor, NGD20001, NHP554B, NHP554P, NI0101 antibody, NI0401, NI0501 antibody, NI0701, NI071, NI1201 antibody, NI1401, Nicip, Niconas, Nicool, NiCord, Nicox, Niflumate, Nigaz, Nikam, Nilitis, Nimace, Nimaid, Nimark-P, Nimaz, Nimcet Juicy, Nime, Nimed, Nimepast, nimesulide, Nimesulix, Nimesulon, Nimica Plus, Nimkul, Nimlin, Nimnat, Nimodol, Nimpidase, Nimsaid-S, Nimser, Nimsy-SP, Nimupep, Nimusol, Nimutal, Nimuwinn, Nimvon-S, Nincort, Niofen, Nipan, Nipent, Nise, Nisolone, Nisopred, Nisoprex, Nisulid, nitazoxanide, Nitcon, nitric oxide, Nizhvisal B, Nizon, NL, NMR1947, NN8209, NN8210, NN8226, NN8555, NN8765, NN8828, NNC014100000100, NNC051869, Noak, Nodevex, Nodia, Nofenac, Noflagma, Noflam, Noflamen, Noflux, Non-antibacterial Tetracyclines, Nonpiron, Nopain, Normferon, Notpel, Notritis, Novacort, Novagent, Novarin, Novigesic, NOXA12, NOXD19, Noxen, Noxon, NPI1302a-3, NPI1342, NPI1387, NPI1390, NPRCS1, NPRCS2, NPRCS3, NPRCS4, NPRCS5, NPRCS6, NPS3, NPS4, nPT-ery, NU3450, nuclear factor NF-kappa-B p65 subunit oligonucleotide, Nucort, Nulojix, Numed-Plus, Nurokind Ortho, Nusone-H, Nutrikemia, Nuvion, NV07alpha, NX001, Nyclobate, Nyox, Nysa, Obarcort, OC002417, OC2286, ocaratuzumab, OCTSG815, Oedemase, Oedemase-D, ofatumumab, Ofgyt-O, Ofvista, OHR118, OKi, Okifen, Oksamen, Olai, olokizumab,

Omeprose E, Omnacortil, Omneed, Omniclor, Omnigel, Omniwel, onercept, ONO4057, ONS1210, ONS1220, Ontac Plus, Ontak, ONX0914, OPC6535, opebacan, OPN101, OPN201, OPN302, OPN305, OPN401, oprelvekin, OPT66, Optifer, Optiflur, OptiMIRA, Orabase Hca, Oradexon, Oraflex, OralFenac, Oralog, Oralpred, Ora-sed, Orasone, orBec, Orbone forte, Orcl, ORE10002, ORE10002, Orenzia, Org214007, Org217993, Org219517, Org223119, Org37663, Org39141, Org48762, Org48775, Orgadrone, Ormoxen, Orofen Plus, Oromylase Biogaran, Orthal Forte, Ortho Flex, Orthoclone OKT3, Orthofen, Orthoflam, Orthogesic, Orthoglu, Ortho-II, Orthomac, Ortho-Plus, Ortinims, Ortofen, Orudis, Oruvail, OS2, Oscart, Osmetone, Ospain, Ossilife, Ostelox, Osteluc, Osteocerin, osteopontin, Osteral, otelixizumab, Otipax, Ou Ning, OvaSave, OX40 Ligand Antibody, Oxa, Oxagesic CB, Oxalgin DP, oxaprozin, OXCQ, Oxeno, Oxib MD, Oxibut, Oxicam, Oxiklorin, Oximal, Oxynal, oxyphenbutazone, Oxyphenbutazone, ozoralizumab, P13 peptide, P1639, P21, P2X7 Antagonists, p38 Alpha Inhibitor, p38 Antagonist, p38 MAP kinase inhibitor, p38alpha MAP Kinase Inhibitor, P7 peptide, P7170, P979, PA401, PA517, Pabi-dexamethasone, PAC, PAC10649, paclitaxel, Painoxam, Paldon, Palima, pamapimod, Pamatase, Panafcort, Panafcortelone, Panewin, PanGraf, Panimun Bioral, Panmesone, Panodin SR, Panslay, Panzem, Panzem NCD, PAP1, papain, Papirzin, Pappen K Pap, Paptinim-D, paquinimod, PAR2 Antagonist, Paracetamol, Paradic, Parafen TAJ, Paramidin, Paranac, Parapar, Parci, parecoxib, Parixam, Parry-S, Partaject Busulfan, pateclizumab, Paxceed, PBI0032, PBI1101, PBI1308, PBI1393, PBI1607, PBI1737, PBI2856, PBI4419, PBI4419, P-Cam, PCI31523, PCI32765, PCI34051, PCI45261, PCI45292, PCI45308, PD360324, PD360324, PDA001, PDE4 inhibitor, PDE-IV Inhibitor, PDL241 antibody, PDL252, PEDIAPRED, Pefree, pegacaristim, Peganix, Peg-Interleukin 12, pegsunercept, Pegsunercept, PEGylated arginine deiminase, peldesine, pelubiprofen, Penacle, penicillamine, Penostop, Pentalgin, Pentasa, Pentaud, pentostatin, Peon, Pepdase, Pepser, Peptirase, Pepzen, Pepzol, Percutalgine, Periochip, Peroxisome Proliferator Activated Receptor gamma modulators, Petizene, PF00344600, PF04171327, PF04236921, PF04308515, PF05230905, PF05280586, PF251802, PF3475952, PF3491390, PF3644022, PF4629991, PF4856880, PF5212367, PF5230896, PF547659, PF755616, PF9184, PG27, PG562, PG760564, PG8395, PGE3935199, PGE527667, PH5, PH797804, PHA408, Pharmaniaga Mefenamic acid, Pharmaniaga Meloxicam, Pheldin, Phenocept, phenylbutazone, PHY702, PI3K delta inhibitor, PI3K Gamma/Delta Inhibitor, PI3K Inhibitor, Picalm, pidotimod, piketoprofen, Pilelife, Pilopil, Pilovate, pimecrolimus, Pipethanen, Piractam, Pirexyl, Pirobet, Piroc, Pirocam, Pirofel, Pirogel, Piromed, Pirozol, Pirox, Piroxen, Piroxicam, piroxicam betadex,

Piroxifar, Piroxil, Piroxim, Pixim, Pixykin, PKC Theta Inhibitor, PL3100, PL5100
Diclofenac, Placenta Polypeptide, Plaquenil, plerixafor, Plocfen, PLR14, PLR18, Plutin,
PLX3397, PLX5622, PLX647, PLX-BMT, pms-Diclofenac, pms-Ibuprofen, pms-
Leflunomide, pms-Meloxicam, pms-Piroxicam, pms-Prednisolone, pms-Sulfasalazine, pms-
Tiaprofenic, PMX53, PN0615, PN100, PN951, podofilox, POL6326, Polcortolon, Polyderm,
Polygam S/D, Polyphlogin, Poncif, Ponstan, Ponstil Forte, Porine-A Neoral, Potaba,
potassium aminobenzoate, Potencort, Povidone, povidone iodine, pralnacasan, Prandin,
Prebel, Precodil, Precortisyl Forte, Precortyl, Predfoam, Predicort, Predicorten, Predilab,
Predilone, Predmetil, Predmix, Predna, Prednesol, Predni, prednicarbate, Prednicort,
Prednidib, Prednifarma, Prednilasca, prednisolone, prednisolone acetate, prednisolone
sodium phosphate, prednisolone sodium succinate, prednisolone sodium succinate,
prednisone, prednisone acetate, Prednitop, Prednol-L, Prednox, Predone, Predonema, Predsol,
Predsolone, Predsone, Predval, Preflam, Prelon, Prenaxol, Prenolone, Preservex, Preservin,
Presol, Preson, Prexige, Priliximab, Primacort, Primmuno, Primofenac, prinaberel, Privigen,
Prixam, Proboxil, Procarne, Prochymal, Procider-EF, Proctocir, Prodase, Prodel B, Prodent,
Prodent Verde, Proepa, Profecom, Profenac L, Profenid, Profenol, Proflam, Proflex, Progesic
Z, proglumetacin, proglumetacin maleate, Prograf, Prolase, Prolixan, promethazine
hydrochloride, Promostem, Promune, PronaB, pronase, Pronat, Prongs, Pronison, Prontoflam,
Propaderm-L, Propodezas, Propolisol, Proponol, propyl nicotinate, Prostaloc, Prostopol,
Protacin, Protase, Protease Inhibitors, Protectan, Proteinase Activated Receptor 2 Inhibitor,
Protufen, Protrin, Proxalyoc, Proxidol, Proxigel, Proxil, Proxym, Prozym, PRT062070,
PRT2607, PRTX100, PRTX200, PRX106, PRX167700, Prysolone, PS031291, PS375179,
PS386113, PS540446, PS608504, PS826957, PS873266, Psorid, PT, PT17, PTL101, P-
Transfer Factor peptides, PTX3, Pulminiq, Pulsonid, Purazen, Pursin, PVS40200, PX101,
PX106491, PX114, PXS2000, PXS2076, PYM60001, Pyralvex, Pyranim, pyrazinobutazone,
Pyrenol, Pyricam, Pyrodex, Pyroxi-Kid, QAX576, Qianbobiyuan, QPI1002, QR440, qT3,
Quiacort, Quidofil, R107s, R125224, R1295, R132811, R1487, R1503, R1524, R1628, R333,
R348, R548, R7277, R788, rabeximod, Radix Isatidis, Radofen, Raipeck, Rambazole,
Randazima, Rapacan, Rapamune, Raptiva, Ravax, Rayos, RDEA119, RDEA436, RDP58,
Reactine, Rebif, REC200, Recartix-DN, receptor for advanced glycation end products
antibody, Reclast, Reclofen, recombinant HSA-TIMP-2, recombinant human alkaline
Phosphatase, recombinant Interferon Gamma, Recominant human alkaline phosphatase,
Reconil, Rectagel HC, Recticin, Recto Menaderm, Rectos, Redipred, Redolet, Refastin,
Regenica, REGN88, Relafen, Relaxib, Relev, Relex, Relifen, Relifex, Relitch, Rematof,

remestemcel-I, Remesulidum, Remicade,, Remsima, Remsima, Remsima, ReN1869, Renacept, Renfor, Renodapt, Renodapt-S, Renta, Reosan, Repare-AR, Reparilexin, reparixin, Repertaxin, Repisprin, Resochin, Resol, resolvin E1, Resurgil, Re-tin-colloid, Retoz, Reumacap, Reumacon, Reumadolor, Reumador, Reumanisal, Reumazin, Reumel, Reumotec, Reuquinol, revamilast, Revascor, Reviroc, Revlimid, Revmoksikam, Rewalk, Rexalgan, RG2077, RG3421, RG4934 antibody, RG7416, RG7624, Rheila, Rheoma, Rheprox, Rheudenolone, Rheufen, Rheugesic, Rheumacid, Rheumacort, Rheumatrex, Rheumesser, Rheumid, Rheumon, Rheumox, Rheuoxib, Rhewlin, Rhucin, RhuDex, Rhulef, Ribox, Ribunal, Ridaura, rifaximin, rilonacept, rimacalib, Rimase, Rimate, Rimatil, Rimesid, risedronate sodium, Ritamine, Rito, Rituxan, rituximab, RNS60, RO1138452, Ro313948, RO3244794, RO5310074, Rob803, Rocamix, Rocas, Rofeb, rofecoxib, Rofee, Rofewal, Roficip Plus, Rojepen, Rokam, Rolodiquim, Romacox Fort, Romatim, romazarit, Ronaben, ronacaleret, Ronoxcin, ROR Gamma T Antagonist, ROR gamma t inverse agonists, Rosecin, rosiglitazone, Rosmarinic acid, Rotan, Rotec, Rothacin, Roxam, Roxib, Roxicam, Roxopro, Roxygin DT, RP54745, RPI78, RPI78M, RPI78MN, RPIMN, RQ00000007, RQ00000008, RTA402, R-Tyflam, Rubicalm, Rubifen, Ruma pap, Rumalef, Rumidol, Rumifen, Runomex, rusalatide acetate, ruxolitinib, RWJ445380, RX10001, Rycloser MR, Rydol, S1P Receptor Agonists, S1P Receptor Modulators, S1P1 Agonist, S1P1 receptor agonist, S2474, S3013, SA237, SA6541, Saaz, S-adenosyl-L-methionine-sulfate-p-toluene sulfonate, Sala, Salazidin, Salazine, Salazopyrin, Salcon, Salicam, salsalate, Sameron, SAN300, Sanaven, Sandimmun, Sandoglobulin, Sanexon, SangCya, SAR153191, SAR302503, SAR479746, Sarapep, sargramostim, Sativex, Savantac, Save, Saxizon, Sazo, SB1578, SB210396, SB217969, SB242235, SB273005, SB281832, SB683698, SB751689, SBI087, SC080036, SC12267, SC409, Scafflam, SCD ketoprofen, SCIO323, SCIO469, SD-15, SD281, SDP051 antibody, Sd-rxRNA, secukinumab, Sedase, Sedilax, Sefdene, Seizyme, SEL113, Seladin, Selecox, selectin P ligand antibody, Glucocorticoid Receptor Agonist, Selectofen, Selektine, SelK1 antibody, Seloxx, Selspot, Selzen, Selzenta, Selzentry, semapimod, semapimod hydrochloride, semparatide, Semparatide, Senafen, Sendipen, Senterlic, SEP119249, Sepdase, Septirose, Seractil, Serafen-P, Serase, Seratid D, Seratiopeptidase, Serato-M, Seratoma Forte, Serazyme, Serezon, Sero, Serodase, Serpicam, Serra, serrapeptase, Serratin, Serratiopeptidase, Serrazyme, Servisone, Seven E P, SGI1252, SGN30, SGN70, SGX203, shark cartilage extract, Sheril, Shield, Shifazen, Shifazen-Fort, Shincort, Shincort, Shiosol, ShK186, Shuanghuangxiaoyan, SI615, SI636, Sigmasporin, Sigmasporin, SIM916, Simpone, Simulect, Sinacort, Sinalgia, Sinapol, Sinatrol, Sinsia, siponimod, Sirolim, sirolimus,

Siropan, Sirota, Sirova, sirukumab, Sistol Forte, SKF105685, SKF105809, SKF106615, SKF86002, Skinalar, Skynim, Skytrip, SLAM family member 7 antibody, Slo-indo, SM101, SM201 antibody, SM401, SMAD family member 7 oligonucleotide, SMART Anti-IL-12 Antibody, SMP114, SNO030908, SNO070131, sodium aurothiomalate, sodium chondroitin sulfate, sodium deoxyribonucleotide, sodium gualenate, sodium naproxen, sodium salicylate, Sodixen, Sofeo, Soleton, Solhidrol, Solicam, Soliky, Soliris, Sol-Melcort, Solomet, Solondo, Solone, Solu-Cort, Solu-Cortef, Solu-Decortin H, Solufen, Solu-Ket, Solumark, Solu-Medrol, Solupred, Somalgen, somatropin, Sonap, Sone, sonepcizumab, Sonexa, Sonim, Sonim P, Soonil, Soral, Sorenil, sotrastaurin acetate, SP-10, SP600125, Spanidin, SP-Cortil, SPD550, Spedace, sperm adhesion molecule 1, Spictol, spleen tyrosine kinase oligonucleotide, Spurin, S-prin, SPWF1501, SQ641, SQ922, SR318B, SR9025, SRT2104, SSR150106, SSR180575, SSS07 antibody, ST1959, STA5326, stabilin 1 antibody, Stacort, Stalogesic, stanozolol, Staren, Starmelox, Stedex IND-SWIFT, Stelara, Stemin, Stenirol, Sterapred, Steriderm S, Sterio, Sterisone, Steron, stichodactyla helianthus peptide, Stickzenol A, Stiefcortil, Stimulan, STNM01, Store Operated Calcium Channel (SOCC) Modulator, STP432, STP900, Stratasin, Stridimmune, Strigraf, SU Medrol, Subreum, Subuton, Succicort, Succimed, Sulan, Sulcolon, Sulfasalazin Heyl, Sulfasalazin, sulfasalazine, Sulfovite, Sulidac, Sulide, sulindac, Sulindex, Sulinton, Sulphafine, Sumilu, SUN597, Suprafen, Supretic, Supsidine, Surgam, Surgamine, Surugamu, Suspen, Suton, Suvenyl, Suwei, SW Dexasone, Syk Family Kinase Inhibitor, Syn1002, Synacran, Synacthen, Synalar C, Synalar, Synavive, Synercort, Sypresta, T cell cytokine-inducing surface molecule antibody, T cell receptor antibody, T5224, T5226, TA101, TA112, TA383, TA5493, tabalumab, Tacedin, Tacgraf, TACIFc5, Tacrobell, Tacrograf, Tacrol, tacrolimus, Tadekinig alpha, Tadolak, TAFA93, Tafirol Artro, Taizen, TAK603, TAK715, TAK783, Takfa, Taksta, talarozole, Talfin, Talmain, talmapimod, Talmea, Talnif, talniflumate, Talos, Talpain, Talumat, Tamalgen, Tamceton, Tamezon, Tandrilax, tannins, Tannosynt, Tantum, tanzisertib, Tapain-beta, Tapoein, Tarenac, tarenflurbil, Tarimus, Tarproxen, Tauxib, Tazomust, TBR652, TC5619, T-cell, immune regulator 1, ATPase, H⁺ transporting, lysosomal V0 subunit A3 antibody, TCK1, T-cort, T-Dexa, Tecelac, Tecon, teduglutide, Teecort, Tegeline, Tementil, temoporfin, Tencam, Tendrone, Tenefuse, Tenfly, tenidap sodium, Tenocam, Tenoflex, Tenoksan, Tenotil, tenoxicam, Tenoxim, Tepadina, Teracort, Teradol, tetomilast, TG0054, TG1060, TG20, TG20, tgAAC94, Th1/Th2 Cytokine Synthase Inhibitor, Th-17 cell inhibitors, Thalido, thalidomide, Thalomid, Themisera, Thenil, Therafectin, Therapyace, thiarabine, Thiazolopyrimidines, thioctic acid, thiotepa, THR090717, THR0921, Threenofen, Thrombate

III, Thymic peptide, Thymodepressin, Thymogam, Thymoglobulin, Thymoglobuline, Thymoject thymic peptides, thymomodulin, thymopentin, thymopolypetides, tiaprofenic acid, tibezoneium iodide, Ticoflex, tilmacoxib, Tilur, T-immune, Timocon, Tiorase, Tissop, TKB662, TL011, TLR4 antagonists, TLR8 inhibitor, TM120, TM400, TMX302, TNF Alpha inhibitor, TNF alpha-TNF receptor antagonist, TNF antibody, TNF receptor superfamily antagonists, TNF TWEAK Bi-Specific, TNF-Kinoid, TNFQb, TNFR1 antagonist, TNR001, TNX100, TNX224, TNX336, TNX558, tocilizumab, tofacitinib, Tokuhon happ, TOL101, TOL102, Tolectin, Tolerimab, Tolerostem, Tolindol, toll-like receptor 4 antibody, toll-like receptor antibody, tolmetin sodium, Tongkeeper, Tonmex, Topflame, Topicort, Topleucon, Topnac, Toppin Ichthammol, toralizumab, Toraren, Torcoxia, Torox, Tory, Toselac, Totaryl, Touch-med, Touchron, Tovok, Toxic apis, Toyolyzom, TP4179, TPCA1, TPI526, TR14035, Tradil Fort, Traficet-EN, Tramace, tramadol hydrochloride, tranilast, Transimune, Transporina, Tratul, Trexall, Triacort, Triakort, Trialon, Triam, triamcinolone, triamcinolone acetate, triamcinolone acetonide, triamcinolone acetonide acetate, triamcinolone hexacetonide, Triamcort, Triamsicort, Trianex, Tricin, Tricort, Tricortone, TricOs T, Triderm, Trilac, Trilisate, Trinocort, Trinolone, Triolex, triptolide, Trisfen, Trivaris, TRK170, TRK530, Trocade, trolamine salicylate, Trolovol, Trosera, Trosera D, Troycort, TRX1 antibody, TRX4, Trymoto, Trymoto-A, TT301, TT302, TT32, TT32, TT33, TT1314, tumor necrosis factor, tumor necrosis factor 2-methoxyethyl phosphorothioate oligonucleotide, tumor necrosis factor antibody, tumor necrosis factor kinoid, tumor necrosis factor oligonucleotide, tumor necrosis factor receptor superfamily, member 1B antibody, tumor necrosis factor receptor superfamily1B oligonucleotide, tumor necrosis factor superfamily, member 12 antibody, tumor necrosis factor superfamily, member 4 antibody, tumor protein p53 oligonucleotide, tumour necrosis factor alpha antibody, TuNEX, TXA127, TX-RAD, TYK2 inhibitors, Tysabri, ubidecarenone, Ucerase, ulodesine, Ultiflam, Ultrafastin, Ultrafen, Ultralan, U-Nice-B, Uniplus, Unitrexate, Unizen, Uphaxicam, UR13870, UR5269, UR67767, Uremol-HC, Urigon, U-Ritis, ustekinumab, V85546, Valcib, Valcox, valdecoxib, Valdez, Valdixx, Valdy, Valentac, Valoxib, Valtune, Valus AT, Valz, Valzer, Vamid, Vantal, Vantelin, VAP-1 SSAO Inhibitor, vapaliximab, varespladib methyl, Varicosin, Varidase, vascular adhesion protein-1 antibody, VB110, VB120, VB201, VBY285, Vectra-P, vedolizumab, Vefren, VEGFR-1 Antibody, Veldona, veltuzumab, Vendexine, Venimmun N, Venoforte, Venoglobulin-IH, Venozel, Veral, Verax, vercirnon, vero-Dexamethasone, Vero-Kladribin, Vetazone, VGX1027, VGX750, Vibex MTX, vidofludimus, Vifenac, Vimovo, Vimultisa, Vincort, Vingraf, Vioform-HC, Vioxl, Vioxx,

Virobron, visilizumab, Vivaglobin, Vivalde Plus, Vivian-A, VLST002, VLST003, VLST004, VLST005, VLST007, Voalla, voclosporin, Vokam, Vokmor, Volmax, Volna-K, Voltadol, Voltagesic, Voltanase, Voltanec, Voltaren, Voltarile, Voltic, Voren, vorsetuzumab, Votan-SR, VR909, VRA002, VRP1008, VRS826, VRS826, VT111, VT214, VT224, VT310, VT346, VT362, VTX763, Vurdon, VX30 antibody, VX467, VX5, VX509, VX702, VX740, VX745, VX745, VX850, W54011, Walacort, Walix, WC3027, Wilgraf, Winflam, Winmol, Winpred, Winsolve, Wintogeno, WIP901, Woncox, WSB711 antibody, WSB712 antibody, WSB735, WSB961, X071NAB, X083NAB, Xantomicin Forte, Xedenol, Xefo, Xefocam, Xenar, Xepol, X-Flam, Xibra, Xicam, Xicotil, Xifaxan, XL499, XmAb5483, XmAb5485, XmAb5574, XmAb5871, XOMA052, Xpress, XPro1595, XtendTNF, XToll, Xtra, Xylex-H, Xynofen SR, Yang Shu-IVIG, YHB14112, YM974, Youfeline, Youfenac, Yuma, Yumerol, Yuroben, YY piroxicam, Z104657A, Zacy, Zaltokin, zaltoprofen, Zap70 Inhibitor, Zeepain, Zeloxim Fort, Zema-Pak, Zempack, Zempred, Zenapax, Zenas, Zenol, Zenos, Zenoxone, Zerax, Zerocam, Zerospasm, ZFNs, zinc oxide, Zipsor, ziralimumab, Zitis, Zix-S, Zocort, Zodixam, Zoftadex, zoledronic acid, Zolfin, Zolterol, Zopyrin, Zoralone, ZORprin, Zortress, ZP1848, zucapsaicin, Zunovate, Zwitterionic polysaccharides, ZY1400, Zybodies, Zycel, Zyrofen, Zyrogen Inhibitors, Zyser, Zytrim, and Zywin-Forte. In addition, the anti-inflammatory drugs, as listed above, may be combined with one or more agents listed above or herein or with other agents known in the art.

[1127] In one embodiment, a drug that reduces, inhibits, prevents and/or ameliorates inflammation, for example, one of the drugs provided above, is delivered to the suprachoroidal space of the eye using the microneedle devices and methods disclosed herein, and is used to treat, prevent and/or ameliorate a disease or disorder selected from arthritis, degenerative arthritis, psoriatic arthritis, arthritic disorders, arthritic pain, arthrosis, autoimmune arthritis, autoimmune diseases, autoimmune disorders, axial spondyloarthritis, chronic prosthetic joint infection, collagen induced arthritis, osteoarthritis, rheumatoid arthritis, senile arthritis, seronegative oligoarthritis of the knee, allergic and autoimmune inflammatory diseases, inflammatory diseases, inflammatory disorders, collagen diseases, discoid Lupus Erythematosus, immune deficiencies, immune diseases, immune disorders, immunodeficiency diseases, immunodeficiency disorders, immunoglobulin (IgG2) deficiency, immunoglobulin deficiency, Inflammation, Lambert-Eaton myasthenia syndrome, polymyositis, dermatomyositis, polyneuritis, post-operative ocular inflammation, polychondritis, sporadic inclusion body myositis, Systemic Lupus Erythematosus, T cell

deficiency, TNF-receptor associated periodic syndrome, tropical spastic paraparesis, Wegener Granulomatosis, X-linked severe combined immunodeficiency disease, Behcet's disease, Crohn's disease, Crohn's Fistula, cutaneous Lupus Erythematosus, acute inflammation, acute inflammatory edema, adrenocortical insufficiency, cerebral inflammation, chronic lung inflammation, corticoid-responsive inflammatory skin disorders, cutaneous inflammation, dermal inflammation, dry skin inflammatory disease, ear edema, ear inflammation, glossitis, inflammatory bowel disease, inflammatory degenerative disease, inflammatory disorders of the eye and/or ear, inflammatory lesions in fungal infections, inflammatory lesions, inflammatory pain, inflammatory skin diseases or disorders, mouth and gum inflammation, mouth and throat inflammation, musculoskeletal disorders, otitis, pelvic inflammatory disease, perianal inflammation, post operative inflammation, pulmonary inflammation, rectal inflammation, refractory idiopathic inflammatory myopathies, seborrhoeic dermatitis, swelling, aphthous ulcerations, chronic polyarthritis, juvenile rheumatoid arthritis, rheumatic diseases, Sjogren's syndrome, ophthalmic for Sjogren's syndrome, transplant rejection, acute allograft rejection, chronic graft rejection, graft versus host disease, humoral rejection in heart transplantation, humoral rejection in kidney transplantation, organ rejection in renal transplantation, solid organ transplant rejection, bronchiolitis obliterans after lung transplantation, rejection of bone marrow transplant, chronic lung transplant rejection, Corneal graft rejection, delayed graft function in kidney transplantation, heart transplant rejection, Homotransplantation rejection, immune rejection of hESC-derived therapeutic grafts, kidney transplant rejection, liver transplant rejection, lung transplant rejection, organ rejection, pancreatic islet transplantation rejection in type I diabetes, renal transplant rejection and xenograft rejection.

[1128] In one embodiment, the drug delivered to the suprachoroidal space using the microneedle devices and methods disclosed herein treats, prevents, and/or ameliorates macular degeneration (e.g., age related macular degeneration, dry age related macular degeneration, exudative age-related macular degeneration, geographic atrophy associated with age related macular degeneration, neovascular (wet) age-related macular degeneration, neovascular maculopathy and age related macular degeneration, occult with no classic choroidal neovascularization (CNV) in age-related macular degeneration, Stargardt's disease, Subfoveal wet Age-Related macular degeneration, and Vitreomacular Adhesion (VMA) associated with Neovascular Age Related macular degeneration). Examples of drugs that treat, prevent and/or ameliorate macular degeneration that can be used in conjunction with the

devices and methods described herein include, but are not limited to: A0003, A36 peptide, AAV2-sFLT01, ACE041, ACU02, ACU3223, ACU4429, AdPEDF, aflibercept, AG13958, aganirsen, AGN150998, AGN745, AL39324, AL78898A, AL8309B, ALN-VEG01, alprostadil, AM1101, amyloid beta antibody, anecortave acetate, Anti-VEGFR-2 Alterase, Aptocine, APX003, ARC1905, ARC1905 with Lucentis, ATG3, ATP-binding cassette, sub-family A, member 4 gene, ATXS10, Avastin with Visudyne, AVT101, AVT2, bertilimumab, bevacizumab with verteporfin, bevasiranib sodium, bevasiranib sodium; with ranibizumab, brimonidine tartrate, BVA301, canakinumab, Cand5, Cand5 with Lucentis, CERE140, ciliary neurotrophic factor, CLT009, CNTO2476, collagen monoclonal antibody, complement component 5 aptamer (pegylated), complement component 5 aptamer (pegylated) with ranibizumab, complement component C3, complement factor B antibody, complement factor D antibody, copper oxide with lutein, vitamin C, vitamin E, and zinc oxide, dalantercept, DE109, dexamethasone with ranibizumab and verteporfin, disitertide, DNA damage inducible transcript 4 oligonucleotide, E10030, E10030 with Lucentis, EC400, eculizumab, EGP, EHT204, embryonic stem cells, human stem cells, endoglin monoclonal antibody, EphB4 RTK Inhibitor, EphB4 Soluble Receptor, ESBA1008, ETX6991, Evizon, Eyebar, EyePromise Five, Eyevi, Eylea, F200, FCFD4514S, fenretinide, fluocinolone acetonide, fluocinolone acetonide with ranibizumab, fms-related tyrosine kinase 1 oligonucleotide, fms-related tyrosine kinase 1 oligonucleotide with kinase insert domain receptor 169, fosbretabulin tromethamine, Gamunex, GEM220, GS101, GSK933776, HC31496, Human n-CoDeR, HYB676, IBI-20089 with Lucentis, iCo-008, Icon1, I-Gold, Ilaris, Iluvien, Iluvien with Lucentis, immunoglobulins, integrin alpha5beta1 immunoglobulin fragments, Integrin inhibitor, IRIS Lutein, I-Sense Ocushield, Isonop, isopropyl unoprostone, JPE1375, JSM6427, KH902, LentiVue, LFG316, LP590, LPO1010AM, Lucentis, Lucentis with Visudyne, Lutein ekstra, Lutein with myrtillus extract, Lutein with zeaxanthin, M200, M200 with Lucentis, Macugen, MC1101, MCT355, mecamylamine, Microplasmin, motexafin lutetium, MP0112, NADPH oxidase inhibitors, Neoretina, neurotrophin 4 gene, Nova21012, Nova21013, NT501, NT503, Nutri-Stulln, ocriplasmin, OcuXan, Oftan Macula, Optrin, ORA102 with Avastin, P144, P17, Palomid 529, PAN90806, Panzem, Panzem, PARP Inhibitors, pazopanib hydrochloride, pegaptanib sodium, PF4523655, PG11047, piribedil, platelet-derived growth factor beta polypeptide aptamer (pegylated), platelet-derived growth factor beta polypeptide aptamer (pegylated) with ranibizumab, PLG101, PMX20005, PMX53, POT4, PRS055, PTK787, ranibizumab, ranibizumab with triamcinolone acetonide, ranibizumabwith verteporfin, ranibizumab with volociximab, RD27, Rescula, Retaane, retinal

pigment epithelial cells, RetinoStat, RG7417, RN6G, RT101, RTU007, SB267268, serpin peptidase inhibitor, clade F, member 1 gene, shark cartilage extract, Shefl, SIR1046, SIR1076, Sirna027, sirolimus, SMTD004, Snelvit, SOD Mimetics, Soliris, sonepcizumab, squalamine lactate, ST602, StarGen, T2TrpRS, TA106, talaporfin sodium, Tauroursodeoxycholic acid, TG100801, TKI, TLCx99, TRC093, TRC105, triamcinolone acetonide with verteporfin, Trivastal Retard, TT30, Ursa, ursodiol, Vangiolum, VAR10200, vascular endothelial growth factor antibody, vascular endothelial growth factor B, vascular endothelial growth factor kinoid, vascular endothelial growth factor oligonucleotide, VAST Compounds, vatalanib, VEGF Inhibitor, verteporfin, Visudyne, Visudyne with Lucentis and dexamethasone, Visudyne with triamcinolone acetonide, Vivis, volociximab, Votrient, XV615, zeaxanthin, ZFP TF, zinc-monocysteine and Zybrestat. In one embodiment, one or more of the macular degeneration treating drugs described above is combined with one or more agents listed above or herein or with other agents known in the art.

[1129] In one embodiment, the methods and devices provided hererin are used to delivery triamcinolone or triamcinolone acetonide to the suprachoroidal space of an eye of a patient in need thereof. In a further embodiment, the triamcinolone or triamcinolone acetonide is delivered for the treatment of sympathetic ophthalmia, temporal arteritis, uveitis and/or ocular inflammatory conditions. In one embodiment, triamcinolone or triamcinolone acetonide is delivered to the suprachoroidal space of the eye in a patient in need of treatment of sympathetic ophthalmia with the methods and devices described herein. In another embodiment, triamcinolone or triamcinolone acetonide is delivered to the suprachoroidal space of the eye in a patient in need of treatment of temporal arteritis with the methods and devices described herein. In yet another embodiment, triamcinolone or triamcinolone acetonide is delivered to the suprachoroidalspace of the eye in a patient in need of treatment of uveitis, with the methods and devices described herein. In another embodiment, triamcinolone or triamcinolone acetonide is delivered to the suprachoroidal space of the eye in a patient in need of treatment of one or more ocular inflammatory conditions, with the methods and devices described herein.

[1130] The triamcinolone composition provided herein, in one embodiment, is a suspension comprising microparticles or nanoparticles of triamcinolone or triamcinolone acetonide. The microparticles, in one embodiment, have a D_{50} of about 3 μm or less. In a further embodiment, the D_{50} is about 2 μm . In another embodiment, the D_{50} is about 2 μm or less.

In even another embodiment, the D_{50} is about 1000 nm or less. The microparticles, in one embodiment, have a D_{99} of about 10 μm or less. In another embodiment, the D_{99} is about 10 μm . In another embodiment, the D_{99} is less than about 10 μm or less than about 9 μm or less.

[1131] In one embodiment, the triamcinolone composition comprises triamcinolone microparticles. In a further embodiment, the composition comprises polysorbate 80. In another embodiment, the triamcinolone composition comprises one or more of CaCl_2 , MgCl_2 , sodium acetate and sodium citrate. In one embodiment, the composition comprises polysorbate 80 at a w/v% of 0.02% or about 0.02%, 0.015% or about 0.015%.

[1132] In certain embodiments the drug delivered to ocular tissues using the microneedle devices and methods disclosed herein treats, prevents, and/or ameliorates fibrosis (e.g. myelofibrosis, fibrosis in diabetic nephropathy, cystic fibrosis, scarring, and skin fibrosis).

[1133] In one embodiment, a drug that treats, prevents and/or ameliorates fibrosis is used in conjunction with the devices and methods described herein, and is delivered to the suprachoroidal space of the eye. In a further embodiment, the drug is Actimmune with Pirfenidone, ACUHTR028, AlphaVBeta5, aminobenzoate potassium, amyloid P, ANG1122, ANG1170, ANG3062, ANG3281, ANG3298, ANG4011, Anti-CTGF RNAi, Aplidin, astragalus membranaceus extract with salvia and schisandra chinensis, atherosclerotic plaque blocker, Azol, AZX100, BB3, connective tissue growth factor antibody, CT140, danazol, Esbriet, EXC001, EXC002, EXC003, EXC004, EXC005, F647, FG3019, Fibrocorin, Follistatin, FT011, Galectin-3 inhibitors, GKT137831, GMCT01, GMCT02, GRMD01, GRMD02, GRN510, Heberon Alfa R, interferon alfa-2b, interferon gamma-1b with pirfenidone, ITMN520, JKB119, JKB121, JKB122, KRX168, LPA1 receptor antagonist, MGN4220, MIA2, microRNA 29a oligonucleotide, MMI0100, noscapine, PBI4050, PBI4419, PDGFR inhibitor, PF-06473871, PGN0052, Pirespa, Pirfenex, pirfenidone, plitidepsin, PRM151, Px102, PYN17, PYN22 with PYN17, Relivergen, rhPTX2 Fusion Proteins, RXI109, secretin, STX100, TGF-beta Inhibitor, transforming growth factor, beta receptor 2 oligonucleotide, VA999260 or XV615. In one embodiment, one or more of the fibrosis treating drugs described above is combined with one or more agents listed above or herein or with other agents known in the art.

[1134] In one embodiment, a drug that treats, prevents and/or ameliorates diabetic macular edema is used in conjunction with the devices and methods described herein, and is delivered

to the suprachoroidal space of the eye. In a further embodiment, the drug is AKB9778, bevasiranib sodium, Cand5, choline fenofibrate, Cortject, c-raf 2-methoxyethyl phosphorothioate oligonucleotide, DE109, dexamethasone, DNA damage inducible transcript 4 oligonucleotide, FOV2304, iCo007, KH902, MP0112, NCX434, Optina, Ozurdex, PF4523655, SAR1118, sirolimus, SK0503 or TriLipix. In one embodiment, one or more of the diabetic macular edema treating drugs described above is combined with one or more agents listed above or herein or with other agents known in the art.

[1135] In one embodiment, a drug that treats, prevents and/or ameliorates macular edema is used in conjunction with the devices and methods described herein, and is delivered to the suprachoroidal space of the eye. In a further embodiment, the drug is denufosol tetrasodium, dexamethasone, ecallantide, pegaptanib sodium, ranibizumab or triamcinolone. In addition, the drugs delivered to ocular tissues using the microneedle devices and methods disclosed herein which treat, prevent, and/or ameliorate macular edema, as listed above, may be combined with one or more agents listed above or herein or with other agents known in the art.

[1136] In one embodiment, a drug that treats, prevents and/or ameliorates ocular hypertension is used in conjunction with the devices and methods described herein and is delivered to the suprachoroidal space of the eye. In a further embodiment, the drug is 2-MeS-beta gamma-CCl₂-ATP, Aceta Diazol, acetazolamide, Aristomol, Arteoptic, AZD4017, Betalamic, betaxolol hydrochloride, Betimol, Betoptic S, Brimodin, Brimonal, brimonidine, brimonidine tartrate, Brinidin, Calte, carteolol hydrochloride, Cosopt, CS088, DE092, DE104, DE111, dorzolamide, dorzolamide hydrochloride, Dorzolamide hydrochloride with Timolol maleate, Droptimol, Fortinol, Glaumol, Hypadil, Ismotiv, isopropyl unoprostone, isosorbide, Latalux, latanoprost, Latanoprost with Timolol maleate, levobunolol hydrochloride, Lotensin, Mannigen, mannitol, metipranolol, mifepristone, Mikelan, Minims Metipranolol, Mirol, nipradilol, Nor Tenz, Ocupress, olmesartan, Ophtalol, pilocarpine nitrate, Piobaj, Rescula, RU486, Rysmon TG, SAD448, Saflutan, Shemol, Taflotan, tafluprost, tafluprost with timolol, Thiaboot, Timocomod, timolol, Timolol Actavis, timolol hemihydrate, timolol maleate, Travast, travoprost, Unilat, Xalacom, Xalatan or Zomilol. In addition, the drugs delivered to ocular tissues using the microneedle devices and methods disclosed herein which treat, prevent, and/or ameliorate ocular hypertension, as listed above,

may be combined with one or more agents listed above or herein or with other agents known in the art.

[1137] In certain embodiments one or more drugs may be delivered to ocular tissues and/or into the suprachoroidal space via the systems and devices described herein. Delivery of one or more drugs into the suprachoroidal space using the microneedle device described herein may be accomplished by using one or more microneedles. In addition, combinations of one or more drugs may be delivered to the suprachoroidal space using the microneedle device described herein in combination with delivery of one or more drugs via intravitreal (IVT) administration (e.g., intravitreal injection, intravitreal implant or eye drops). Methods of IVT administration are well known in the art. Examples of drugs that can be administered via IVT include, but are not limited to: A0003, A0006, Acedolone, AdPEDF, aflibercept, AG13958, aganirsen, AGN208397, AKB9778, AL78898A, amyloid P, Angiogenesis Inhibitor Gene Therapy, ARC1905, Aurocort, bevasiranib sodium, brimonidine, Brimonidine, brimonidine tartrate, bromfenac sodium, Cand5, CERE140, Ciganclor, CLT001, CLT003, CLT004, CLT005, complement component 5 aptamer (pegylated), complement factor D antibody, Cortiject, c-raf 2-methoxyethyl phosphorothioate oligonucleotide, cyclosporine, triamcinolone, DE109, denufosol tetrasodium, dexamethasone, dexamethasone phosphate, disitertide, DNA damage inducible transcript 4 oligonucleotide, E10030, ecallantide, EG3306, Eos013, ESBA1008, ESBA105, Eylea, FCFD4514S, fluocinolone acetonide, fms-related tyrosine kinase 1 oligonucleotide, fomivirsen sodium, fosbretabulin tromethamine, FOV2301, FOV2501, ganciclovir, ganciclovir sodium, GS101, GS156, hyaluronidase, IBI20089, iCo007, Iluvien, INS37217, Isonop, JSM6427, Kalbitor, KH902, lerdelimumab, LFG316, Lucentis, M200, Macugen, Makyueido, Microplasmin, MK0140, MP0112, NCX434, neurotrophin 4 gene, OC10X, ocriplasmin, ORA102, Ozurdex, P144, P17, Palomid 529, pazopanib hydrochloride, pegaptanib sodium, Plasma Kallikrein Inhibitors, platelet-derived growth factor beta polypeptide aptamer (pegylated), POT4, PRM167, PRS055, QPI1007, ranibizumab, resveratrol, Retilone, retinal pigment epithelium-specific protein 65kDa gene, Retisert, rod derived cone viability factor, RPE65 Gene Therapy, RPGR Gene Therapy, RTP801, Sd-rxRNA, serpin peptidase inhibitor clade F member 1 gene, Sirna027, sirolimus, sonpimizumab, SRT501, STP601, TG100948, Trabio, triamcinolone, triamcinolone acetonide, Trivaris, tumor necrosis factor antibody, VEGF/rGel-Op, verteporfin, Visudyne, Vitrase, Vitrasert, Vitravene, Vitreals, volociximab, Votrient, XG102, Xibrom, XV615, and Zybrestat. Accordingly, the methods of the present invention include administering via IVT

one or more of the drugs listed above in combination with one or more drugs disclosed herein administered into the suprachoroidal space using the microneedle device described herein.

[1138] In one embodiment, the drug is formulated for storage and delivery via the microneedle device described herein. The “drug formulation” is a formulation of a drug, which typically includes one or more pharmaceutically acceptable excipient materials known in the art. The term “excipient” refers to any non-active ingredient of the formulation intended to facilitate handling, stability, dispersibility, wettability, release kinetics, and/or injection of the drug. In one embodiment, the excipient may include or consist of water or saline.

[1139] In one embodiment, the fluid drug formulation includes microparticles or nanoparticles, each of which can include at least one drug. Desirably, the microparticles or nanoparticles provide for the controlled release of drug into the ocular tissue. As used herein, the term “microparticle” encompasses microspheres, microcapsules, microparticles, and beads, having a number average diameter of 1 to 100 μm , most preferably 1 to 25 μm . The term “nanoparticles” are particles having a number average diameter of 1 to 1000 nm. Microparticles may or may not be spherical in shape. “Microcapsules” are defined as microparticles having an outer shell surrounding a core of another material. The core can be liquid, gel, solid, gas, or a combination thereof. In one case, the microcapsule may be a “microbubble” having an outer shell surrounding a core of gas, wherein the drug is disposed on the surface of the outer shell, in the outer shell itself, or in the core. Microbubbles may respond to acoustic vibrations as known in the art for diagnosis and/or can be used to burst the microbubble to release its payload at/into a select ocular tissue site. “Microspheres” can be solid spheres, can be porous and include a sponge-like or honeycomb structure formed by pores or voids in a matrix material or shell, or can include multiple discrete voids in a matrix material or shell. The microparticle or nanoparticles may further include a matrix material. The shell or matrix material may be a polymer, amino acid, saccharide, or other material known in the art of microencapsulation.

[1140] The drug-containing microparticles or nanoparticles may be suspended in an aqueous or non-aqueous liquid vehicle. The liquid vehicle may be a pharmaceutically acceptable aqueous solution, and optionally may further include a surfactant. The microparticles or nanoparticles of drug themselves may include an excipient material, such as a polymer, a

polysaccharide, a surfactant, etc., which are known in the art to control the kinetics of drug release from particles.

[1141] In one embodiment, the fluid drug formulation further includes an agent effective to degrade collagen or GAG fibers in the sclera, which may enhance penetration/release of the drug into the ocular tissues. This agent may be, for example, an enzyme, such as hyaluronidase, a collagenase, or a combination thereof. In a variation of this method, the enzyme is administered to the ocular tissue in a separate step from—preceding or following—infusion of the drug. The enzyme and drug are administered at the same site.

[1142] In another embodiment, the drug formulation is one that undergoes a phase change upon administration. For instance, a liquid drug formulation may be injected through hollow microneedles into the suprachoroidal space, where it then gels and the drug diffuses out from the gel for controlled release.

[1143] While the embodiments and methods herein describe delivering a medicament to a target tissue, the embodiments described herein can be configured to facilitate a biopsy procedure and/or removal of a substance from a target location.

[1144] While the embodiments have been described above in use on ocular tissue, in some instances, the embodiments and methods described herein can be used on any other suitable bodily tissue. For example, in some instances, the use of an adjustable length needle can be beneficial in conjunction with standard phlebotomy techniques during drug infusion and/or blood draw from a vein. Thus, while the embodiments and methods are specifically described above in use on ocular tissue, it should be understood that the embodiments and methods have been presented by way of example only, and not limitation.

[1145] While various embodiments have been described above, it should be understood that they have been presented by way of example only, and not limitation. Where methods described above indicate certain events occurring in certain order, the ordering of certain events may be modified. Additionally, certain of the events may be performed concurrently in a parallel process when possible, as well as performed sequentially as described above.

[1146] Although the systems and methods are shown and described herein as providing for delivery of medicaments in the suprachoroidal space, in other embodiments, the systems and the methods described herein can be applicable for delivery of any suitable therapeutic

substance to any portion of the eye, such as, the cornea, the retinal area or the vitreous. In other embodiments, any of the systems, methods and devices described herein can be used to deliver any suitable therapeutic substance to any desired target tissue (including non-ocular tissue).

[1147] In other embodiments, the cannulas, microneedles and/or methods can be used for delivery of medicaments into any suitable portion of the body, including dermal injections or the like.

[1148] Where schematics and/or embodiments described above indicate certain components arranged in certain orientations or positions, the arrangement of components may be modified. Similarly, where methods and/or events described above indicate certain events and/or procedures occurring in certain order, the ordering of certain events and/or procedures may be modified. While the embodiments have been particularly shown and described, it will be understood that various changes in form and details may be made.

[1149] Although various embodiments have been described as having particular features and/or combinations of components, other embodiments are possible having a combination of any features and/or components from any of embodiments as discussed above.

CLAIMS

1. An apparatus, comprising:
 - a hub configured to be coupled to a medicament container, the hub defining a passageway, the hub having a distal end surface configured to contact a target surface of a target tissue; and
 - a puncture member coupled within the passageway of the hub, the puncture member defining a lumen therethrough in fluid communication with the medicament container when the hub is coupled to the medicament container, a distal end portion of the puncture member extending distally from the distal end surface of the hub, a proximal end portion of the puncture member defining a first inner diameter, the distal end portion of the puncture member defining a second inner diameter, the second diameter smaller than the first diameter.
2. The apparatus of claim 1, wherein the target tissue is an eye and the target surface is any one of a conjunctiva of the eye or a sclera of the eye.
3. The apparatus of claim 1, wherein the distal end surface of the hub includes a sealing portion configured to define a substantially fluid-tight seal with the target surface, the sealing portion surrounding a centerline of the puncture member.
4. The apparatus of claim 1, wherein the puncture member is a microneedle, a length of the distal end portion of the microneedle that extends distally from the distal end surface of the hub being between about 200 microns and about 1500 microns.
5. The apparatus of claim 1, wherein the puncture member is a microneedle, the second inner diameter being 30 gauge or smaller, the distal end portion of the microneedle including a beveled surface.
6. The apparatus of claim 1, further comprising:
 - the medicament container coupled to the hub, the medicament container containing at least one of a VEGF, a VEGF inhibitor, or a combination thereof.

7. The apparatus of claim 1, wherein the puncture member is a microneedle, the apparatus further comprising:

the medicament container coupled to the hub, the medicament container containing a medicament having a viscosity of at least about 100 centiPoise, the medicament container including an actuation rod disposed therein such that movement of the actuation rod within the medicament container conveys the medicament through the lumen of the microneedle,

the second inner diameter being 30 gauge or smaller, a length of the distal end portion of the microneedle being such that the medicament is conveyed through the lumen when a force of less than about 6 N is exerted on the actuation rod.

8. The apparatus of claim 7, wherein the medicament has a viscosity of at least about 1000 centiPoise.

9. An apparatus, comprising:

a medicament container containing a medicament having a viscosity of at least about 100 centiPoise, the medicament container including an actuation rod disposed therein;

a hub configured to be coupled to the medicament container, the hub defining a passageway, the hub having a distal end surface configured to contact a target surface of a target tissue; and

a microneedle coupled within the passageway of the hub, the microneedle defining a lumen in fluid communication with the medicament container when the hub is coupled to the medicament container, a distal end portion of the microneedle extending distally from the distal end surface of the hub, the distal end portion of the microneedle defining an inner diameter being 30 gauge or smaller, a length of the distal end portion of the microneedle being such that the medicament is conveyed through the lumen when a force of less than about 6 N is exerted on the actuation rod.

10. The apparatus of claim 9, wherein the length of the distal end portion of the microneedle is less than an overall length of the microneedle.

11. The apparatus of claim 9, wherein the length of the distal end portion of the microneedle is between about 200 microns and about 1500 microns.

12. The apparatus of claim 9, wherein the target tissue is an eye and the target surface is any one of a conjunctiva of the eye or a sclera of the eye.
13. The apparatus of claim 9, wherein the medicament has a viscosity of at least about 1000 centiPoise.
14. An apparatus, comprising:
 - a medicament container containing a medicament, the medicament container including an elastomeric member disposed therein such that movement of the elastomeric member conveys the medicament within the medicament container;
 - a hub configured to be coupled to the medicament container; and
 - a needle configured to be coupled to the medicament container via the hub, the needle defining a lumen in fluid communication with the medicament container, a distal end portion of the needle defining an inner diameter being 30 gauge or smaller, a length of the distal end portion of the needle being between about 200 microns and about 1500 microns, a proximal end portion of the needle defining an inner diameter being 27 gauge or bigger, the needle including a transition portion between the proximal end portion and the distal end portion, an outer surface of the transition portion configured to contact a target surface of a target tissue during an injection event.
15. The apparatus of claim 14, wherein the outer surface of the transition portion has a conical shape.
16. The apparatus of claim 14, wherein the outer surface of the transition portion has a curved, convex shape.
17. The apparatus of claim 14, wherein:
 - the needle is monolithically constructed;
 - the outer surface of the transition portion has a curved, convex shape; and
 - a length of the distal end portion of the needle extending beyond the transition portion is between about 200 microns and about 1500 microns.
18. The apparatus of claim 14, wherein:
 - the needle is monolithically constructed;

the outer surface of the transition portion has a curved, convex shape, the outer surface is configured to form a seal with the target surface of the target tissue.

19. The apparatus of claim 14, wherein:

The medicament has a viscosity of at least about 100 Poise; and
the needle is configured such that the medicament is conveyed through the lumen when a force of less than about 6 N is exerted on the elastomeric member.

20. The apparatus of claim 19, further comprising:

an actuator rod in contact with the elastomeric member, the actuator rod configured to receive the force to move the elastomeric member.

21. An apparatus, comprising:

a medicament container assembly;
a needle in fluid communication with the medicament container assembly;
a hub configured to be operatively coupled to a distal end portion of the medicament container assembly, the hub defining a first passageway, the hub having a distal end surface configured to contact a target surface of a target tissue; and
a compressible member disposed between the hub and the distal end portion of the medicament container assembly, the compressible member defining a second passageway, the first passageway and the second passageway being aligned to receive at least a portion of the needle therethrough, the compressible member configured to be compressed in response to a force exerted on the medicament container assembly such that a thickness of the compressible member reduces from a first thickness to a second thickness.

22. The apparatus of claim 21, wherein a distal end portion of the needle extends distally from the distal end surface of the hub when the compressible member is compressed.

23. The apparatus of claim 21, wherein a distal end portion of the needle extends distally from the distal end surface of the hub by a first length when the compressible member has the first thickness, the distal end portion of the needle extends distally from the distal end surface of the hub by a second length when the compressible member has the second thickness.

24. The apparatus of claim 23, wherein the second length is between about 200 microns and about 1500 microns.
25. The apparatus of claim 21, wherein at least one of the hub or the medicament container assembly includes a stopping mechanism configured to limit the compression of the compressible member when the force is exerted on the medicament container assembly.
26. The apparatus of claim 21, wherein the target tissue is an eye and the target surface is any one of a conjunctiva of the eye or a sclera of the eye.
27. The apparatus of claim 21, wherein the distal end surface of the hub includes a sealing portion configured to define a substantially fluid-tight seal with the target surface, the sealing portion surrounding a centerline of the puncture member.
28. The apparatus of claim 21, wherein the compressible member is constructed from at least one of a rubber, a silicone, a hydrogel, a sol-gel, a foam, a sponge, or an aerogel.
29. The apparatus of claim 21, wherein the compressible member includes a spring.
30. The apparatus of claim 21, wherein:
the force is less than about 6 N; and
the compressible member is configured to be compressed by about 300 microns from the first thickness to the second thickness in response to the force.

Fig. 1

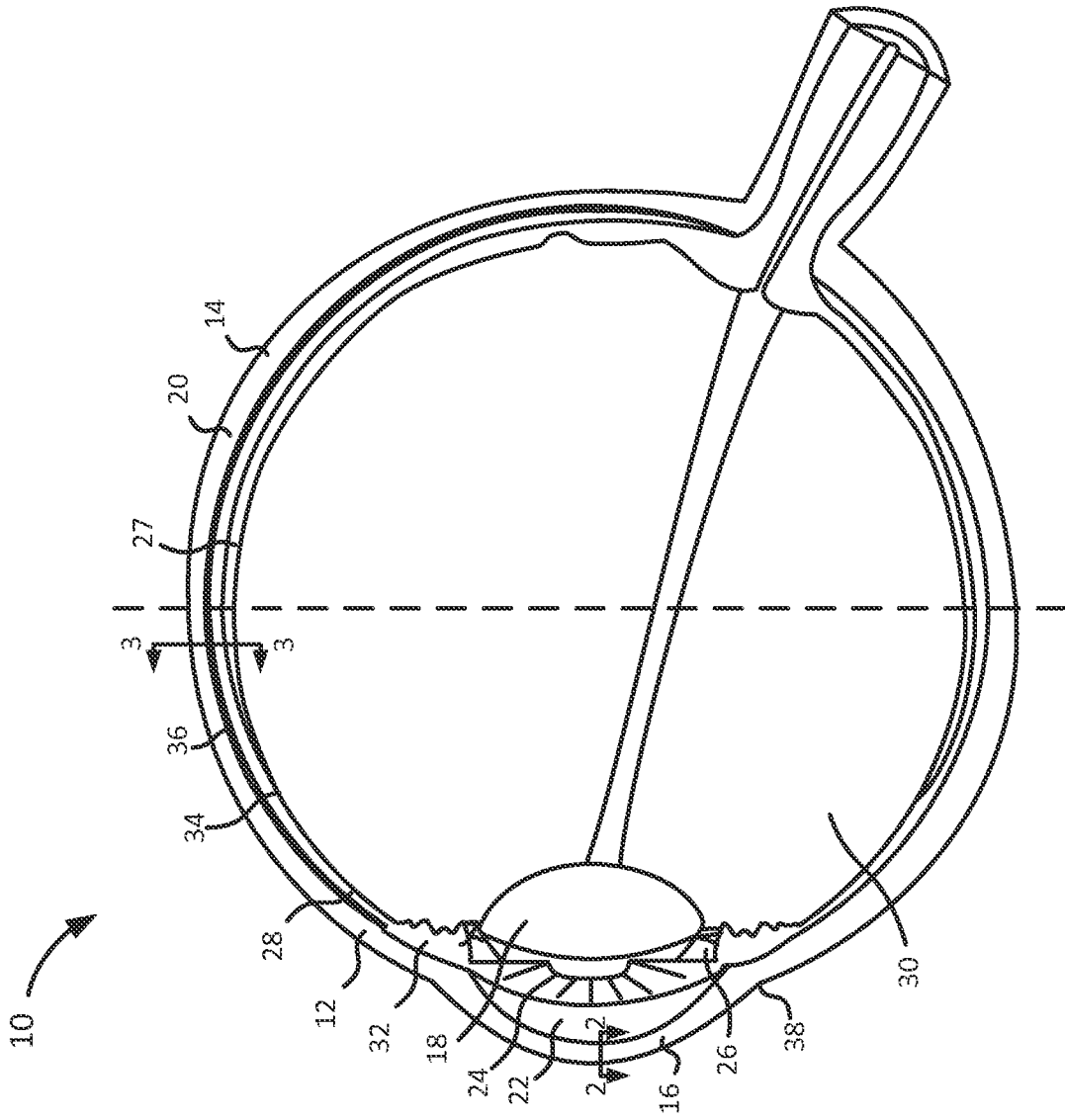

Fig. 2

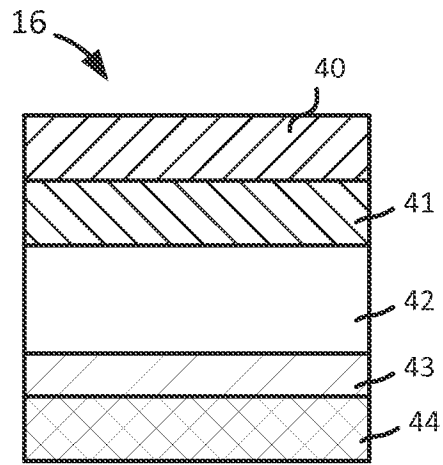

Fig. 3

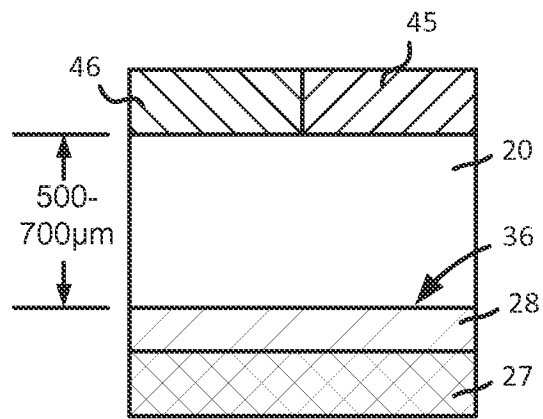

Fig. 4

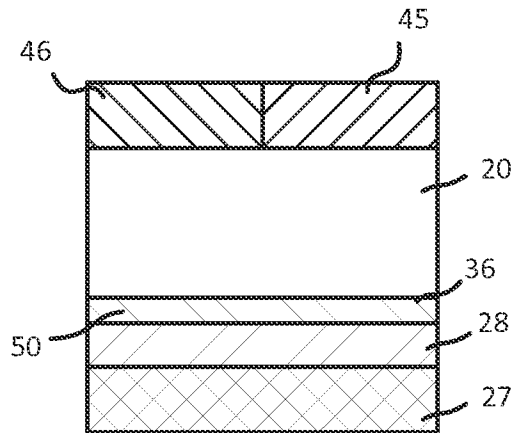

Fig. 5

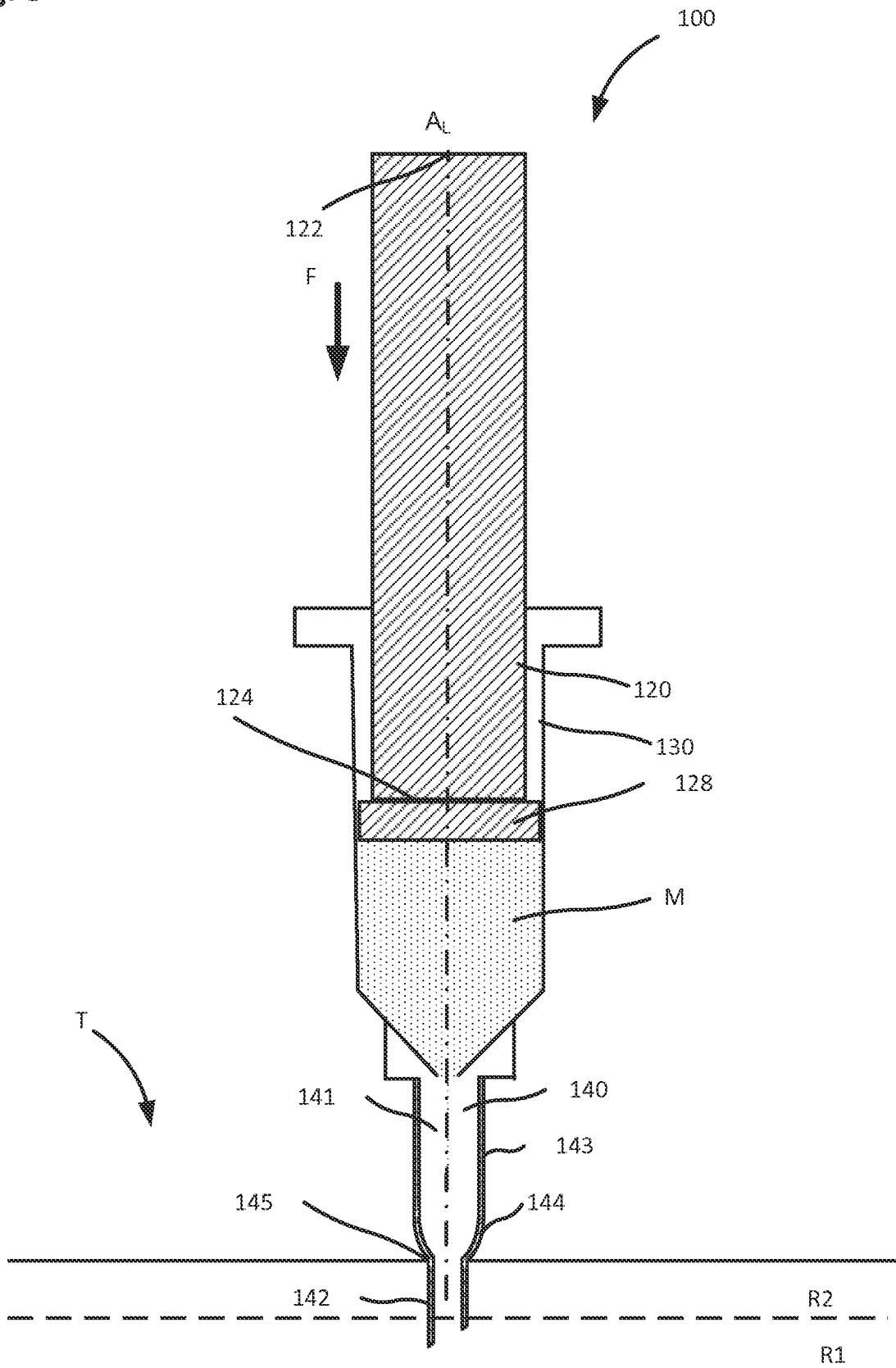

Fig. 6

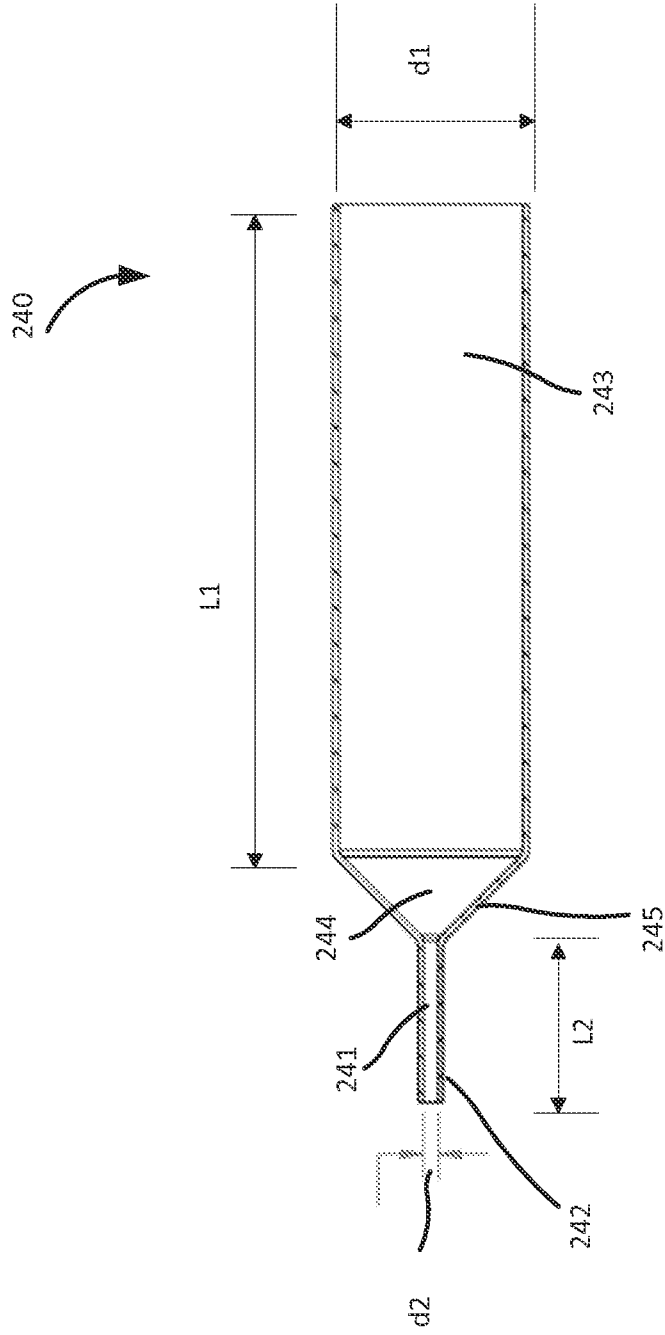

Fig. 7

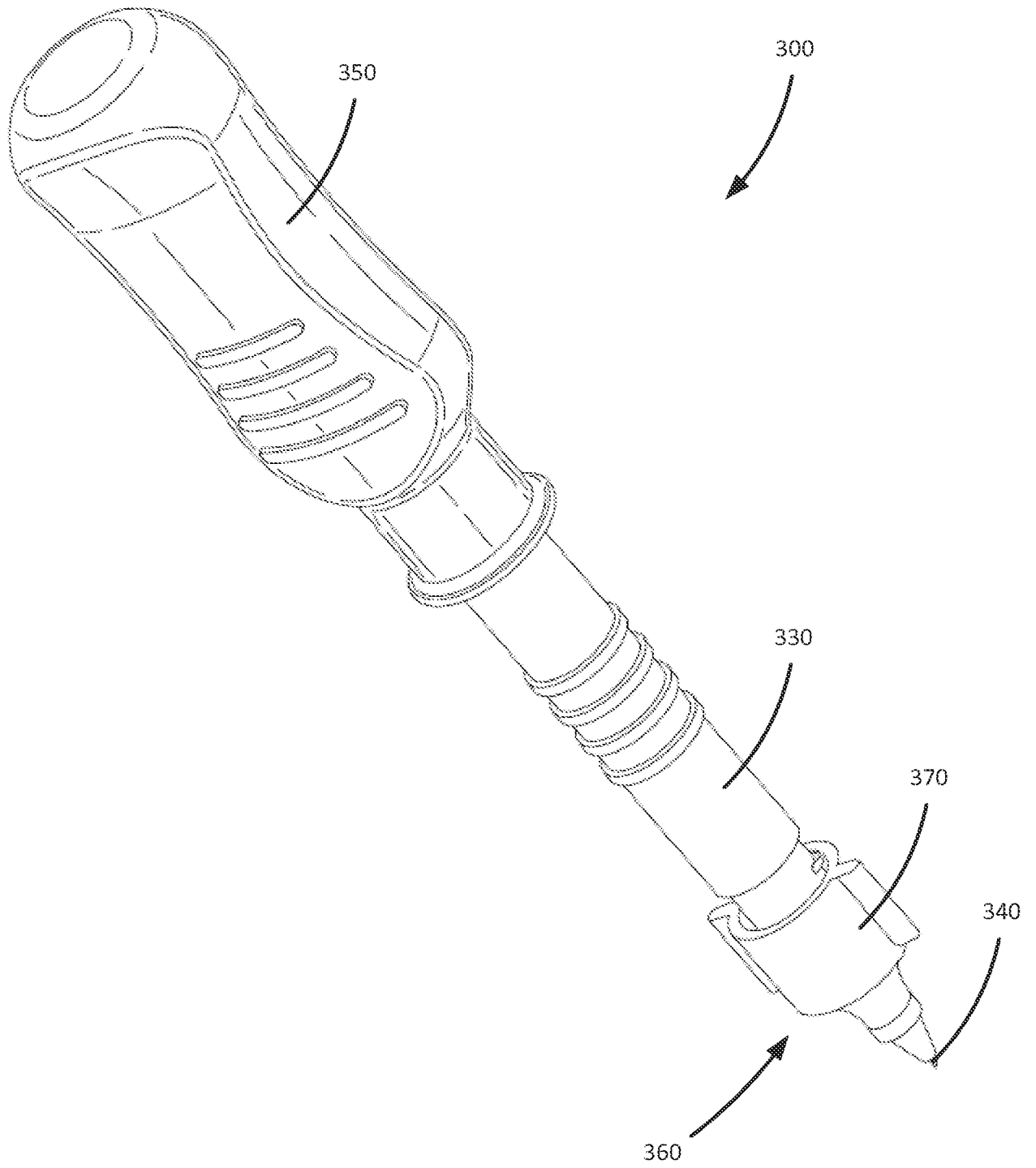

Fig. 9

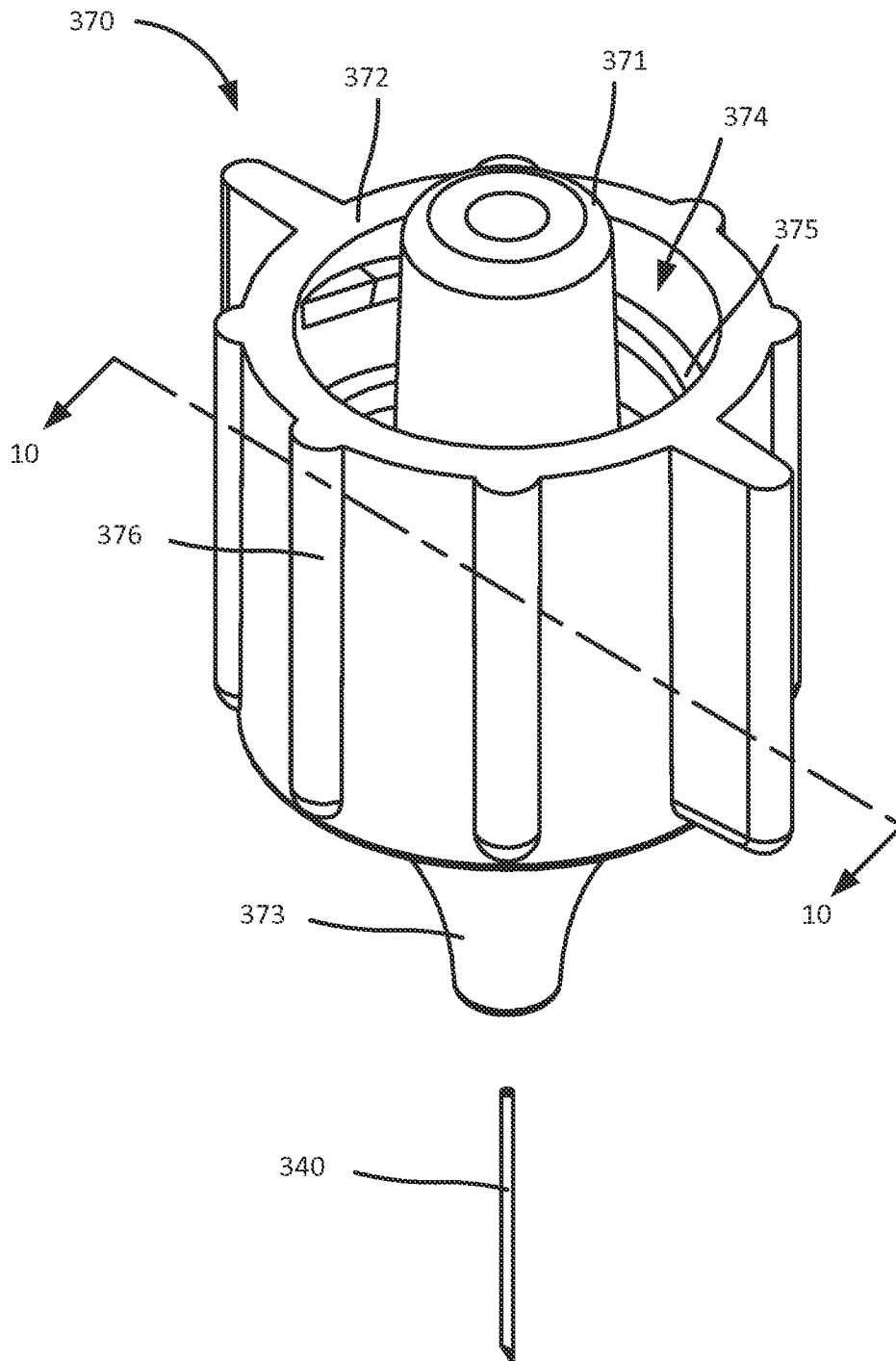
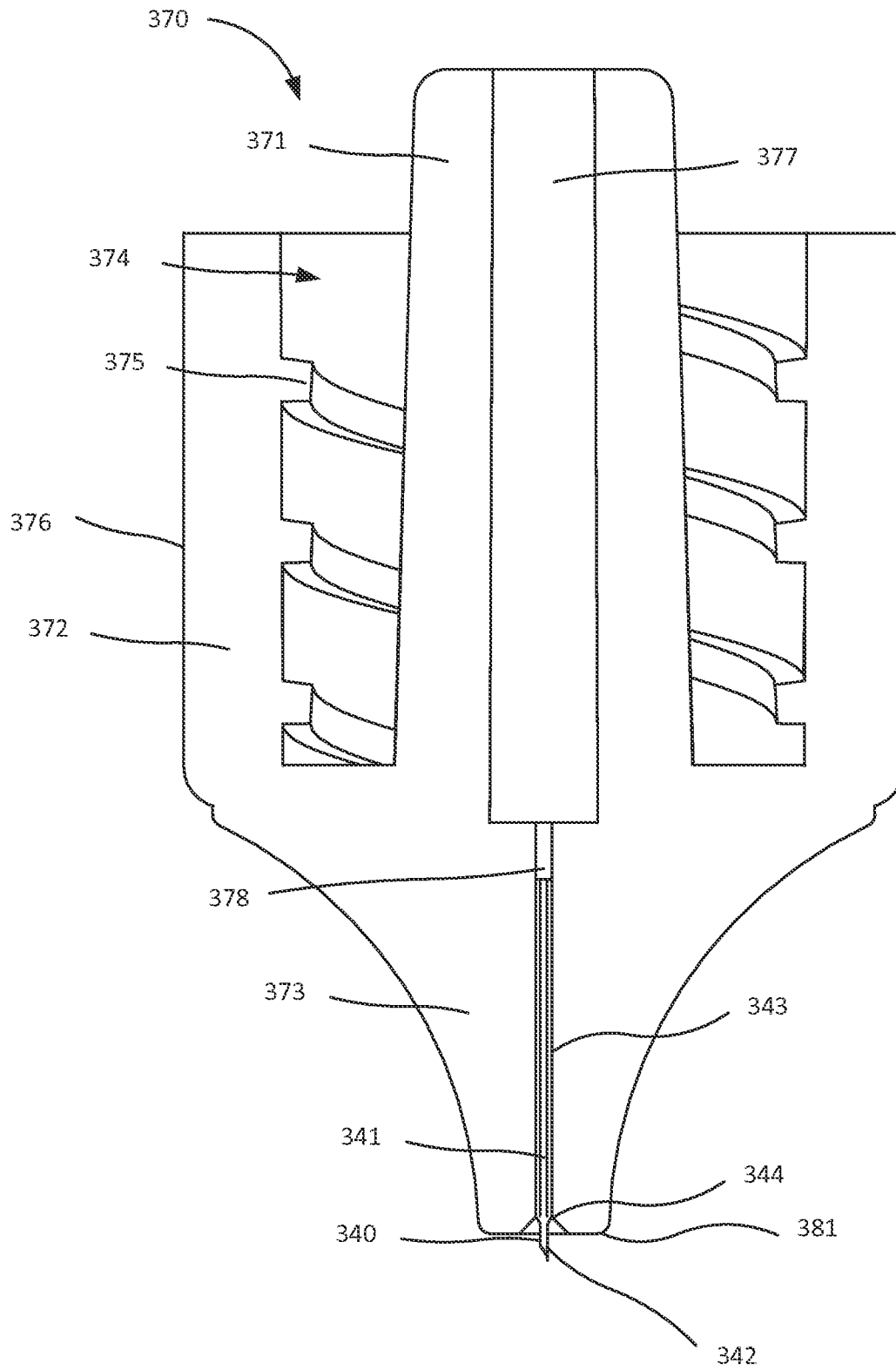

Fig. 10



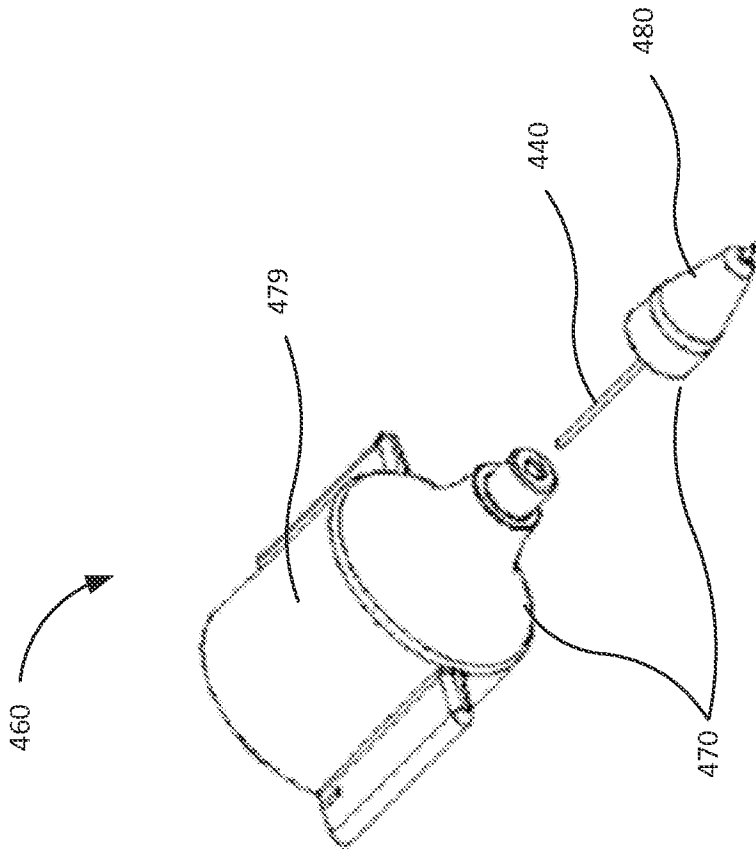

Fig. 11A

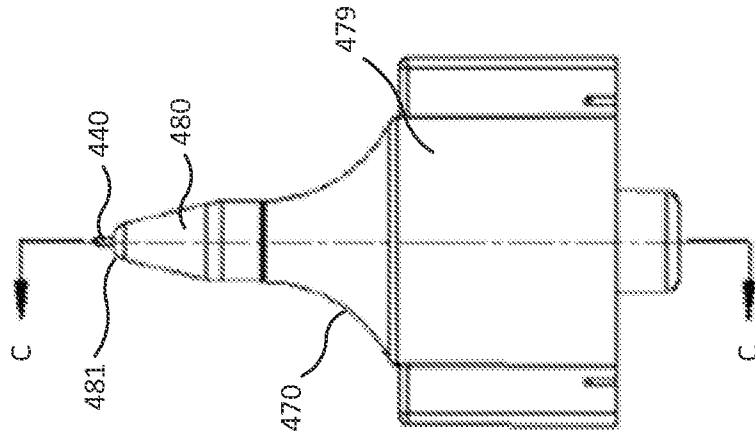

Fig. 11B

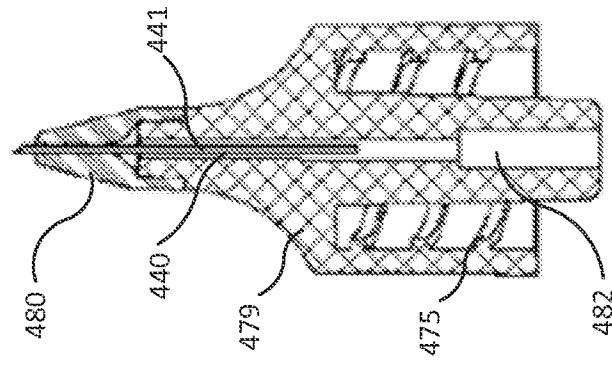

Fig. 11C

Fig. 12

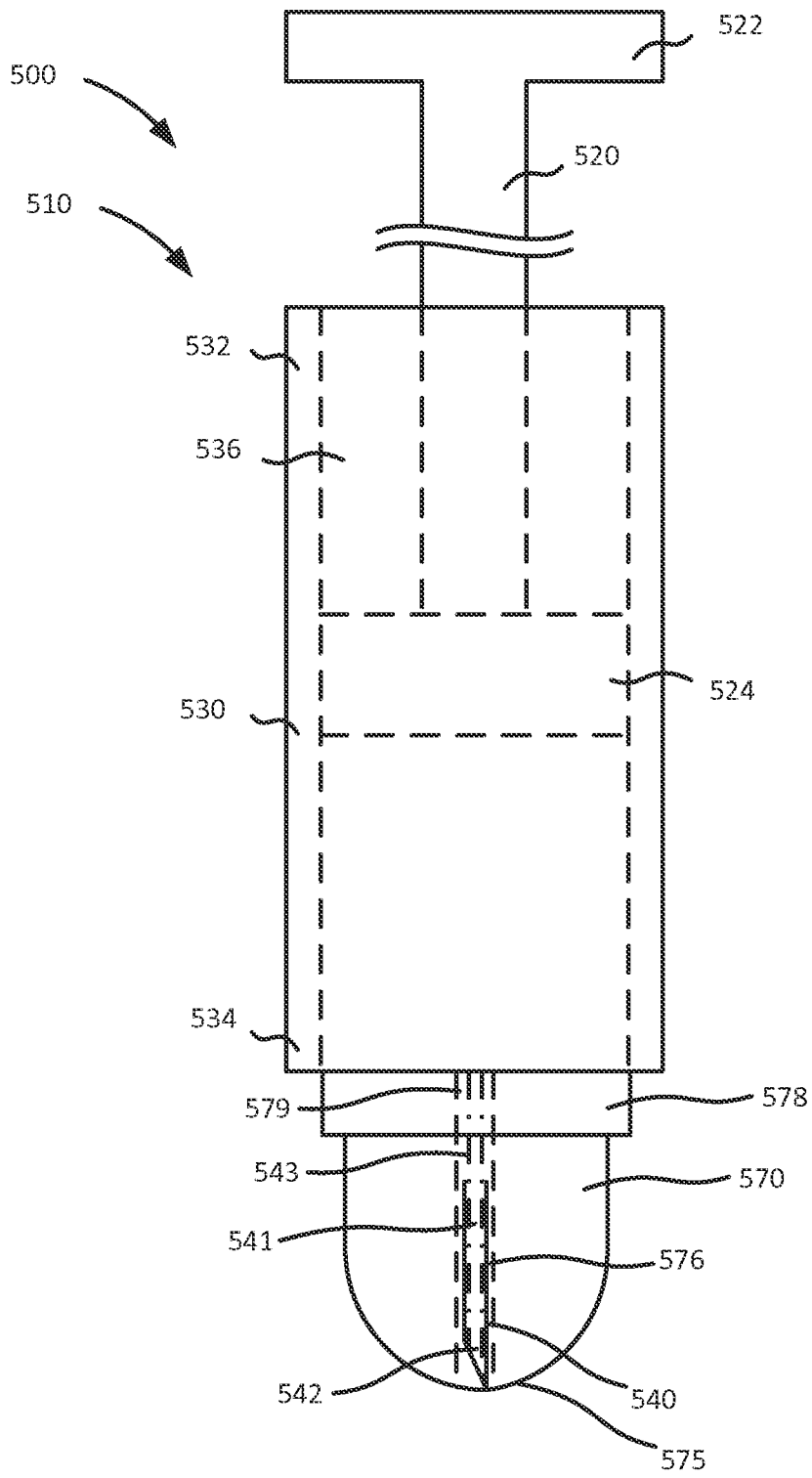

Fig. 13

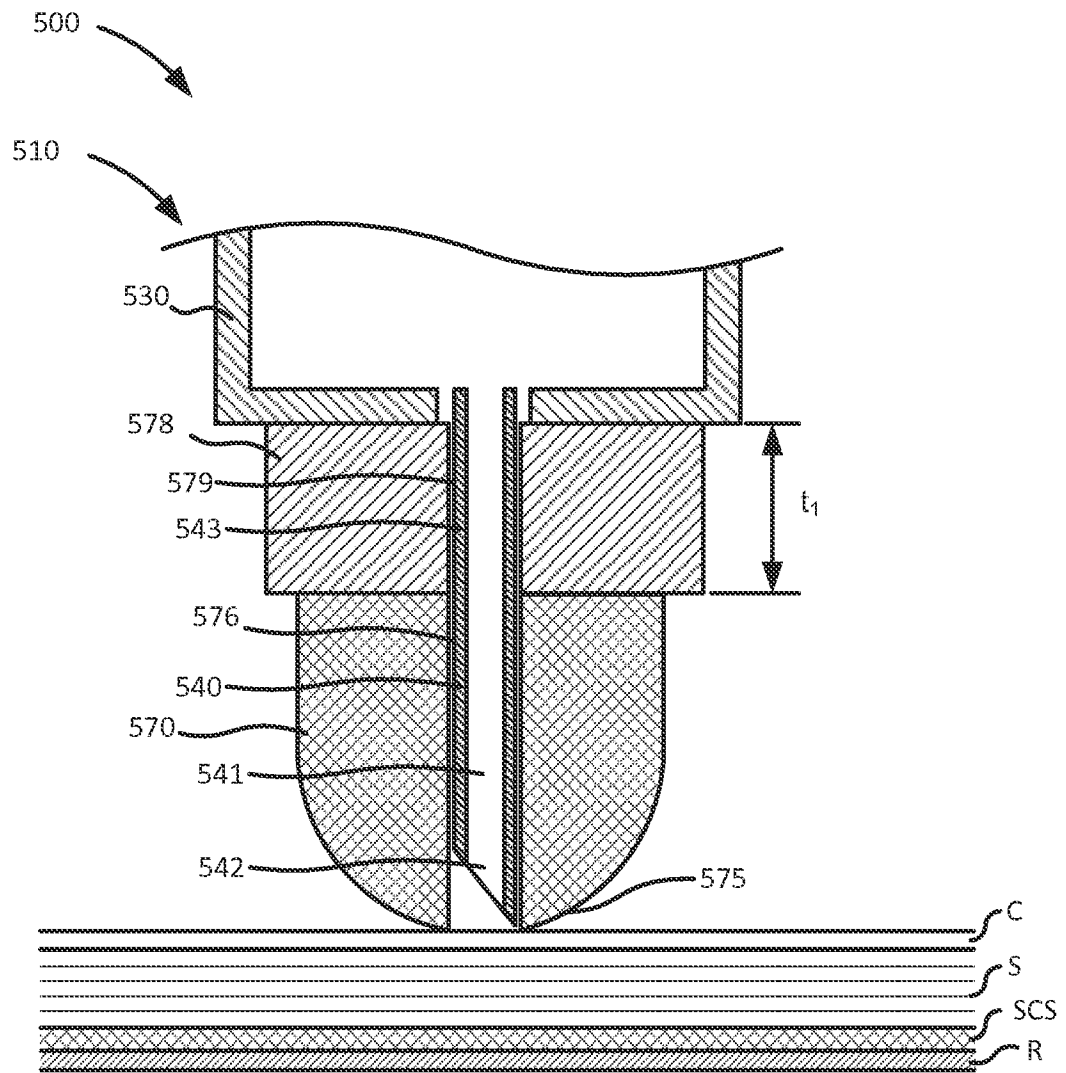

Fig. 14

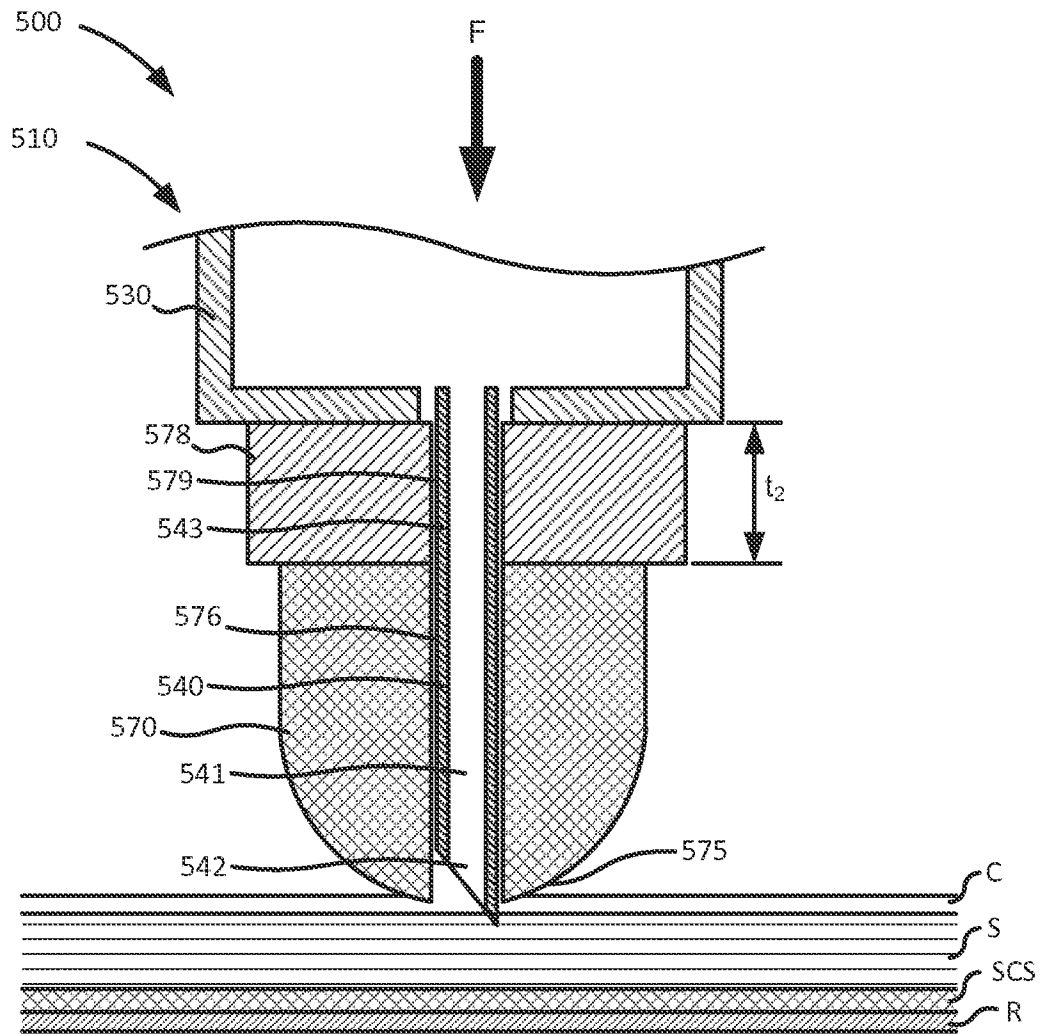

Fig. 15

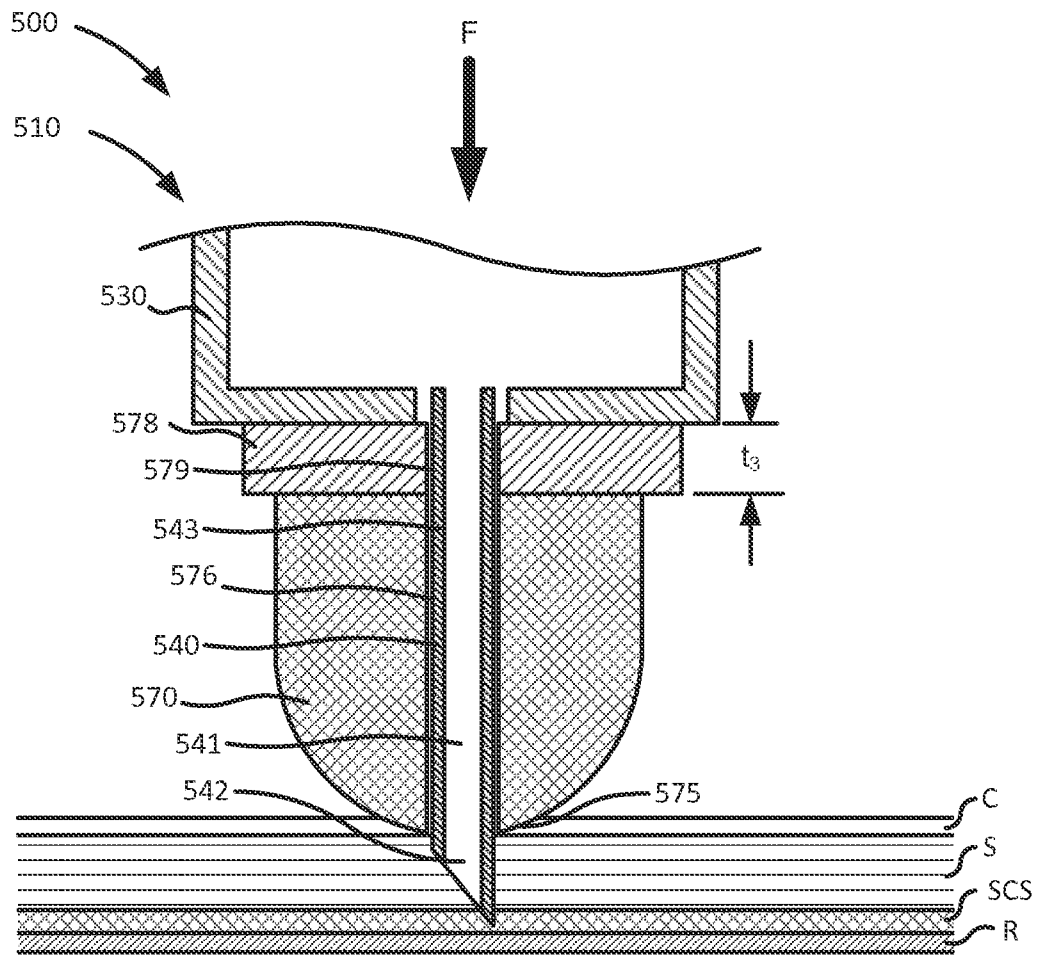

Fig. 16

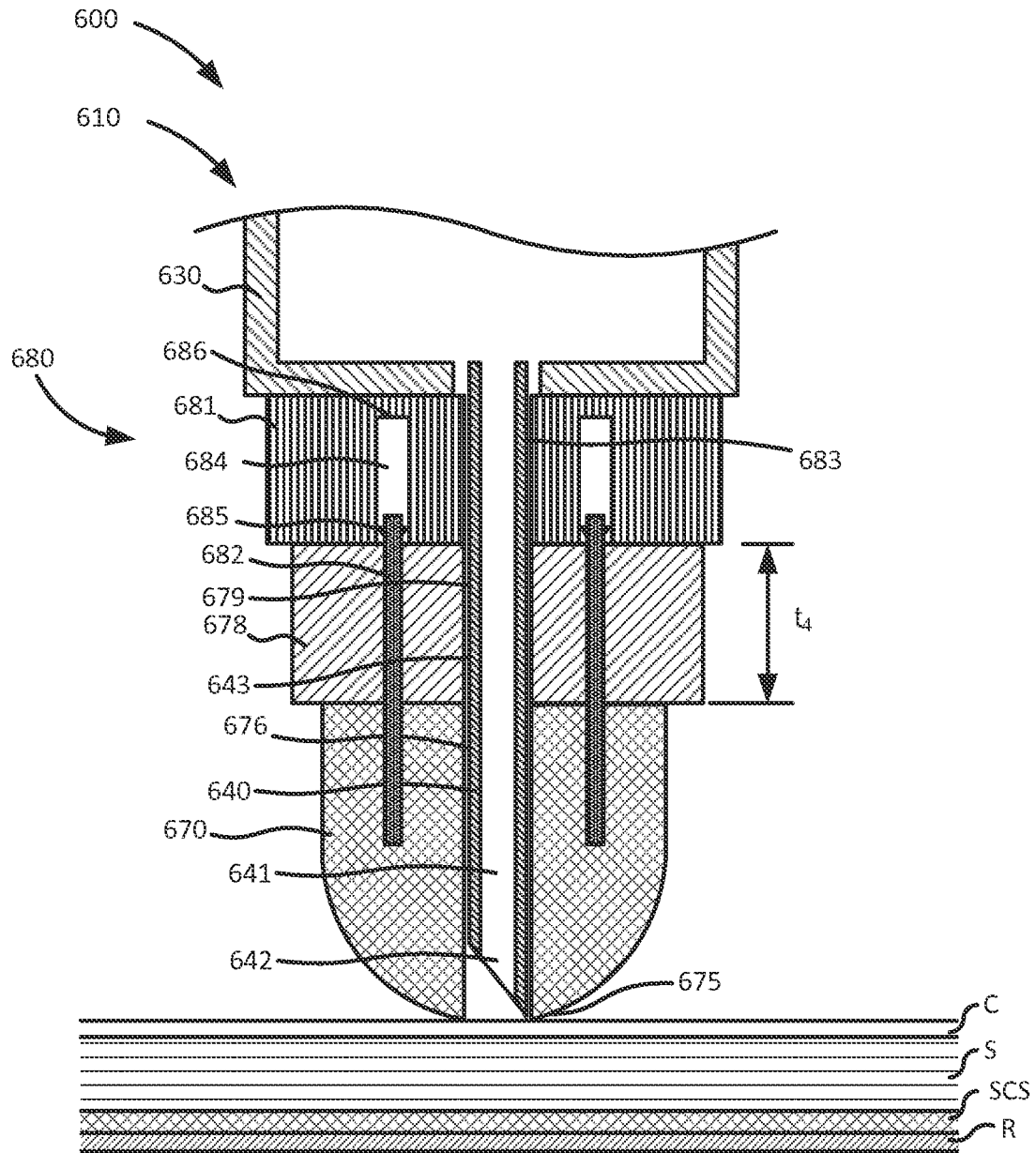

Fig. 17

