

(No Model.)

H. G. RUST & E. S. LYNN.
ATTACHMENT FOR SIGNAL LANTERNS.

No. 577,786.

Patented Feb. 23, 1897.

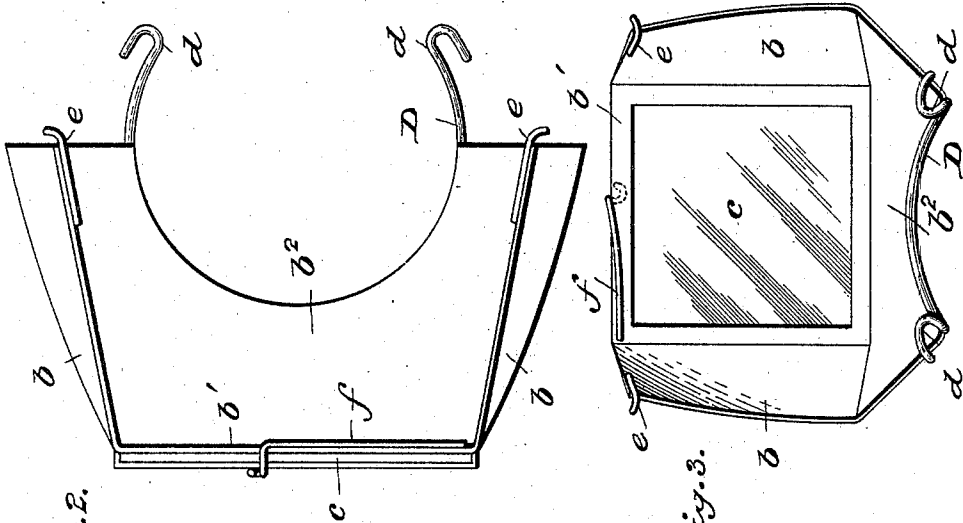

Fig. 2.

Fig. 3.

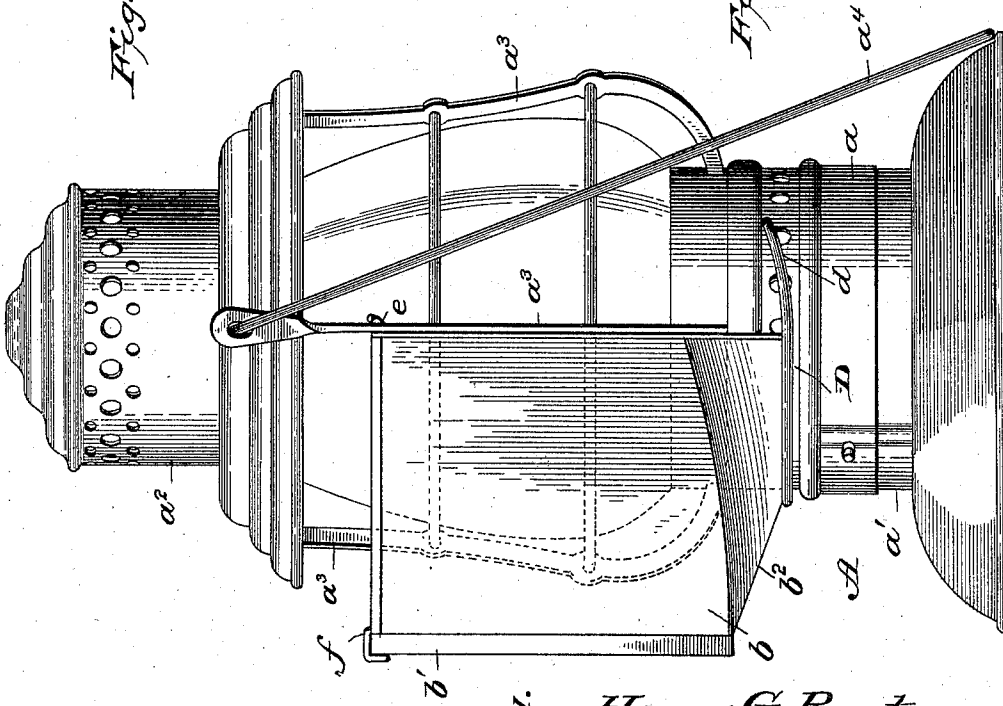
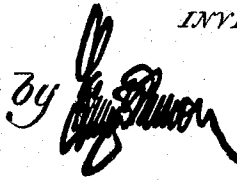

Fig. 1.

Henry G. Rust
Edwin S. Lynn
INVENTORS

WITNESSES
L. J. Elliott.
W. Johnson.

by  Attorney

UNITED STATES PATENT OFFICE.

HENRY G. RUST AND EDWIN STANTON LYNN, OF TOPEKA, KANSAS.

ATTACHMENT FOR SIGNAL-LANTERNS.

SPECIFICATION forming part of Letters Patent No. 577,786, dated February 23, 1897.

Application filed July 16, 1896. Serial No. 599,360. (No model.)

To all whom it may concern:

Be it known that we, HENRY G. RUST and EDWIN STANTON LYNN, citizens of the United States of America, residing at Topeka, in the county of Shawnee and State of Kansas, have invented certain new and useful Improvements in Attachments for Signal-Lanterns; and we do hereby declare the following to be a full, clear, and exact description of the invention, such as will enable others skilled in the art to which it appertains to make and use the same, reference being had to the accompanying drawings, and to letters of reference marked thereon, which form a part of this specification.

This invention relates to improvements in signal-lanterns of that class in which the lantern is provided with means for changing the color of the light, said means being entirely removable, so as to leave said lantern free when required for signaling with the ordinary white light.

The object of the invention is to provide a frame which is of peculiar construction to fit or engage certain parts of a signal-lantern of the ordinary type, and when in such engagement will be firmly held in place, as well as capable of being readily removed when desired, said frame presenting blinds for the sides of the lantern and having grooves or guides to receive glasses of the colors used in railroading.

With the above ends in view the invention consists in the particular construction of a supplemental frame carrying a colored glass and adapted to be removably attached to a signal-lantern, all as will be hereinafter fully described, and particularly pointed out in the claim.

In the accompanying drawings, forming part of this specification, Figure 1 is a side elevation showing the application of the invention to a signal-lantern. Fig. 2 is a plan view of the supplemental frame for the colored glass. Fig. 3 is a rear end view of same.

The signal-lantern A is of the ordinary construction or style employed in railroading, the casing being made up of a lower flat ring a , having the usual pins which engage the oil-reservoir a' , said flat ring being connected to the top or chimney a^2 by bars or supports a^3 , which are curved to correspond with the

shape of the globe and are connected to each other by the usual wire rings. The lantern-casing also has an ordinary handle or bail a^4 in swinging engagement with the extended ends of opposite supporting-bars a^3 .

Our improved supplemental frame for carrying colored glasses is made up of sheet metal, which is stamped or otherwise shaped to present side wings or blinds b , a front section b' , providing an opening, and a bottom plate b^2 . The front section is rectangular and consists of inwardly-projecting parallel flanges, forming guides and seats for the colored glasses, the upper part of said section presenting cross pieces or strips, between which the glass is slid to rest in the seats between the side and bottom flanges. The plate b^2 , which connects the lower ends of the wings b and front open section b' , is inclined, as shown, and the rear end of said plate is curved to bear against the ring a of the lantern, resting upon the bead formed on said ring. This curved inner edge has soldered or otherwise secured thereto a piece of spring-wire D, the ends d of which project beyond the plate and are curved inward, the terminals being bent outward to form grasping portions. It will be noted that the wire D embraces the flat ring a of the wire to prevent outward movement of the lower part of the supplemental frame, and the inner edge of the plate b^2 or wire D carried thereby rests upon the bead to prevent a vertical movement thereof.

The upper edges of the side pieces or wings b of the supplemental frame are each provided at their rear end with a short piece of wire soldered or otherwise connected thereto, and one end of these wires projects beyond the rear edge of the side pieces or wings and is bent outward to form hooks for the purpose hereinafter explained.

The upper end of the front open section of the supplemental frame has attached thereto a spring-arm f , the free end of which is bent outward to overlie the transverse slot or opening through which the glass is passed to hold said glass in place. This supplemental frame provides a very simple and effective device for applying colored glasses to lanterns, and in attaching the device the lower end is first placed in engagement with the flat ring a of

the lantern by causing the spring-wire D to embrace the same, and the upper rear ends of the side pieces or wings *b* are then pressed slightly inward, so that the hooked ends of the wires *e* can be brought into engagement with the adjoining vertical bars of the lantern-casing, the resiliency of the sheet-metal sides or wings serving to maintain this engagement, and the spring tendency of the wire D serves to securely hold the lower part of the supplemental frame in engagement with the lantern. The glass *c* can be readily changed for another by moving the spring-arm *f* to one side to permit of the removal and insertion of the glasses. By this arrangement the trainman can readily change the color to be displayed, and by removing the supplemental frame has a lantern which he can use for ordinary purposes or for signaling with a white light.

Having thus described our invention, what we claim as new, and desire to secure by Letters Patent, is—

The combination with a signal-lantern constructed substantially as shown provided with vertical bars and a flat ring having a

bead, of a supplemental frame for supporting colored glasses in connection with said lantern made up of sheet metal shaped to present side wings *b b*, a front section consisting of parallel flanges and cross pieces or strips, and a bottom plate the inner end of which is curved to correspond with the arc of the flat ring of the lantern; together with a spring-wire D secured to the curved end of the bottom plate and having projecting ends which are curved to embrace the flat ring, hooks *e* attached to the upper ends of the wings, and a flat spring *f* overlying the upper end of the front section *b'*, the lower end of the supplemental frame being adapted to bear upon the bead of the flat ring of the lantern, substantially as shown and for the purpose set forth.

In testimony whereof we affix our signatures in presence of two witnesses.

HENRY G. RUST.
EDWIN STANTON LYNN.

Witnesses:

JOHN H. RUMP,
A. SCHEIFE.