

(No Model.)

2 Sheets—Sheet 1.

J. MILLS.

DUMPING WAGON.

No. 245,202.

Patented Aug. 2, 1881.

Fig. 1.

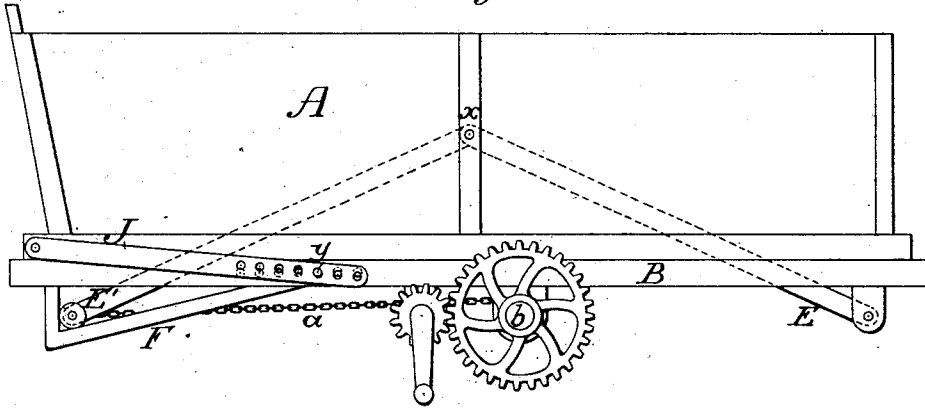
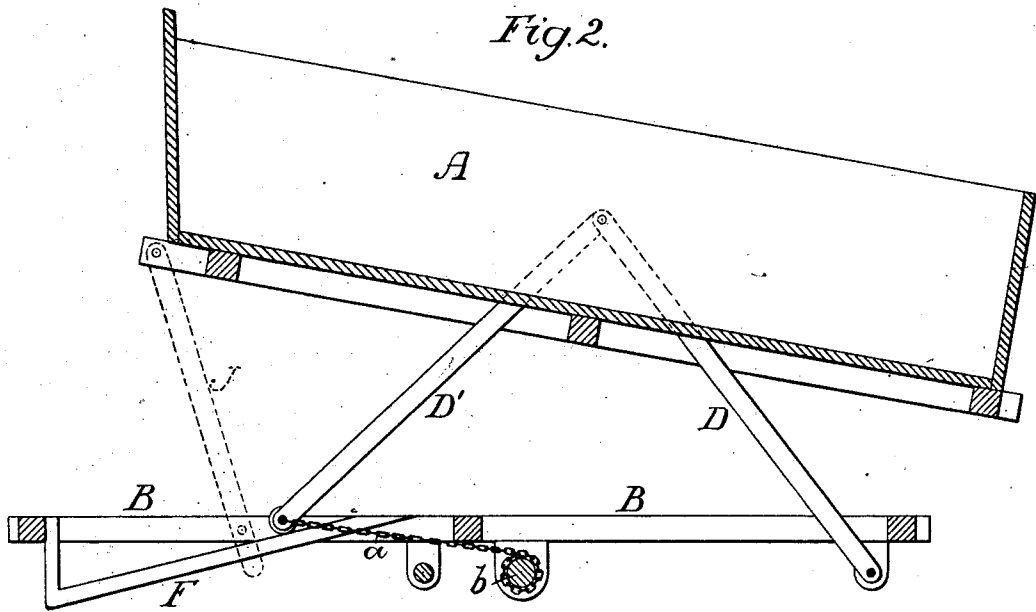

Fig. 2.



Witnesses
James F. Tobin
Harry Smith

Inventor
James Mills
by his Attorneys
Howell and Fry

UNITED STATES PATENT OFFICE.

JAMES MILLS, OF WILMINGTON, DELAWARE.

DUMPING-WAGON.

SPECIFICATION forming part of Letters Patent No. 245,202, dated August 2, 1881.

Application filed May 23, 1881. (No model.)

To all whom it may concern:

Be it known that I, JAMES MILLS, a citizen of the United States, residing in Wilmington, New Castle county, Delaware, have invented certain Improvements in Dumping-Wagons, of which the following is a specification.

My invention relates to certain improvements in the coal-wagon for which Letters Patent No. 218,999 were granted to James Mills and John Mills, Jr., August 26, 1879, my present improvements consisting of certain modifications of the hoisting mechanism, whereby, while retaining all the advantages of the former construction as regards the central pivoting of the body and the facility for elevating the same, I am enabled to cause a further rearward movement of the body than was possible with the former arrangement.

In the accompanying drawings, Figure 1 is a side view, partly in section, of sufficient of a coal-wagon to illustrate my improvements; Fig. 2, the same with the body elevated; and Fig. 3, Sheet 2, a perspective diagram of the elevating structure.

A is the body of the wagon, and B the sills forming part of the frame, the axles and running-gear not being shown, as they form no part of my invention.

The body A is hung at points midway or thereabout of its length to two pairs of arms, D D' and E E', the pivot on one side of the body receiving the upper ends of the arms D D' and the pivot on the opposite side of the body being adapted to the upper ends of the arms E E'. The lower end of the arm D is hung to a fixed pin carried by a projection on one of the sills B, and the lower end of the arm E is hung to a fixed pin on a projection of the opposite sill. The lower ends of the arms D' and E' are furnished with rollers adapted to traverse inclined ways F on the sills B, a transverse bar connecting the ends of the arms D' and E' and serving for the attachment of one end of a chain or rope, *a*, the opposite end of which is wound round a shaft, *b*, adapted to bearings on the sills B, suitable gearing being provided whereby the shaft can be turned so as to wind the chain thereon and draw the lower ends of the arms D' and E' rearward, thus causing the arms D and E to turn on their pivots and

thereby move the supporting-pivots *x* of the body A upward and rearward in arcs of circles concentric with the pivots of said arms D and E. By this means I am enabled to impart a much more extended rearward movement to the body A than was possible in the construction formerly patented, in which the lower ends of the arms D and E were caused to traverse longitudinally, as well as the lower ends of the arms D' and E', the movement of the pivot *x* in our former cart or wagon being substantially vertical. The increased rearward movement of the body is obtained without defeating the objects of the former invention as regards the height of elevation of the body and the facility with which the same can be tilted when elevated, owing to the central pivoting of the body to the arms.

The body may be tilted either during or after the elevating operation; and in order to readily accomplish this result I hang to the front end of the body, A, one end of a link, J, the opposite end of which is pivoted to one of the sills B of the frame by a pin, *y*. The distance between this pivot *y* and the point of connection of the link to the body A governs the degree of inclination imparted to the body, the inclination increasing as the distance between said points is increased. In order that the position of the pivot in respect to the point of connection of the link may be readily varied as the inclination to be imparted to the body may suggest, I form in the link and in the sill B a number of openings, to any coinciding pair of which the pivot-pin may be applied, the effective length of the link being thus increased or diminished.

When the pin is adjusted to the openings previous to the elevation of the body A, the tilting of the latter will be accomplished automatically as it is raised; but if desired the link may be disconnected from the sill B during the elevation of the body A, and may then be manipulated so as to impart the proper inclination to said body, being retained in position after adjustment by inserting the pin.

In the drawings I have shown a wagon with double sides, inclosing spaces for the reception of the arms; but the latter may be arranged on the outside of the body, if desired, and instead

of pivoting the body directly to the upper ends of the arms, as shown, the arms may be pivoted to a block, and the latter may carry the pivots for the body. In some cases, also, the link J may be pivoted to the body at the upper end and adapted at the lower end to a rack on the frame, the position of the lower end of the link on the rack governing the inclination of the body.

10 I claim as my invention—

1. The combination of the frame or sills B, having ways F, the elevating structure comprising opposite pairs of arms D D' and E E', the lower ends of the arms D and E being hung to fixed pivots on the frame or sills and the lower ends of the arms D' and E' being free to move on the ways F, mechanism for moving

said arms D' and E', and the body A pivoted to the elevating structure midway of its length, as set forth. 20

2. The combination of the frame or sills, an elevating structure, substantially as described, a body pivoted to said structure midway of its length, and a link, J, hung to the body and having a variable point of connection to or support on the frame or sills, as set forth. 25

In testimony whereof I have signed my name to this specification in the presence of two subscribing witnesses.

JAMES MILLS.

Witnesses:

EDGAR A. FINLEY,

SAML. H. WILSON.