



(19) **United States**

(12) **Patent Application Publication**
Saunders

(10) **Pub. No.: US 2002/0193866 A1**

(43) **Pub. Date: Dec. 19, 2002**

(54) **METHOD AND APPARATUS FOR DIRECT LASER CUTTING OF METAL STENTS**

now Pat. No. 5,780,807, which is a continuation of application No. 08/345,501, filed on Nov. 28, 1994, now abandoned.

(76) Inventor: **Richard J. Saunders**, Redwood City, CA (US)

Publication Classification

Correspondence Address:
FULWIDER PATTON LEE & UTECHT, LLP
HOWARD HUGHES CENTER
6060 CENTER DRIVE
TENTH FLOOR
LOS ANGELES, CA 90045 (US)

(51) **Int. Cl.⁷** **A61F 2/06; B23K 26/38**
(52) **U.S. Cl.** **623/1.15; 219/121.72**

(57) **ABSTRACT**

An improved expandable stent for implantation in a body lumen, such as an artery, and an improved method for making it from a single length of tubing. The stent consists of a plurality of radially expandable cut cylindrical elements generally aligned on a common axis and interconnected by one or more interconnective elements, the elements having a rectangular cross-section from cut-to-cut. The individual radially expandable cylindrical elements are disposed in an undulating pattern. The stent is manufactured by direct laser cutting from a single metal tube using a finely focused laser beam passing through a coaxial gas jet structure to impinge on the working surface of the tube as the linear and rotary velocity of the tube is precisely controlled.

(21) Appl. No.: **10/117,484**

(22) Filed: **Apr. 5, 2002**

Related U.S. Application Data

(60) Division of application No. 09/687,313, filed on Oct. 13, 2000, now Pat. No. 6,369,355, which is a division of application No. 09/114,656, filed on Jul. 13, 1998, now Pat. No. 6,131,266, which is a division of application No. 08/783,698, filed on Jan. 15, 1997,

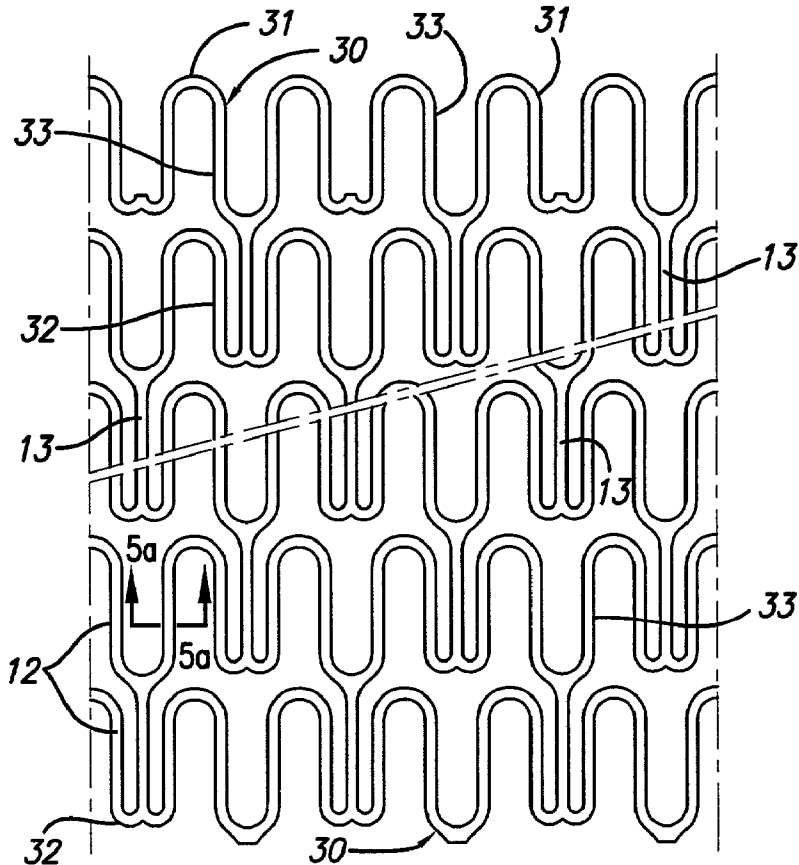

FIG. 1

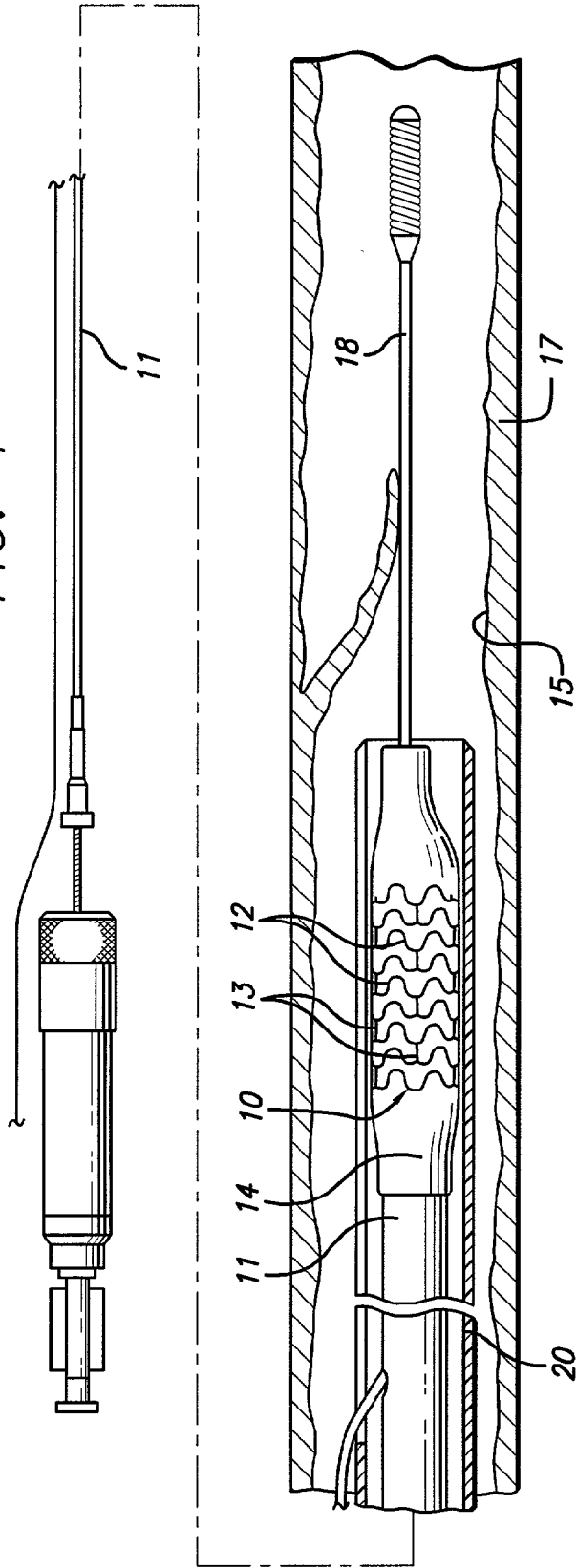
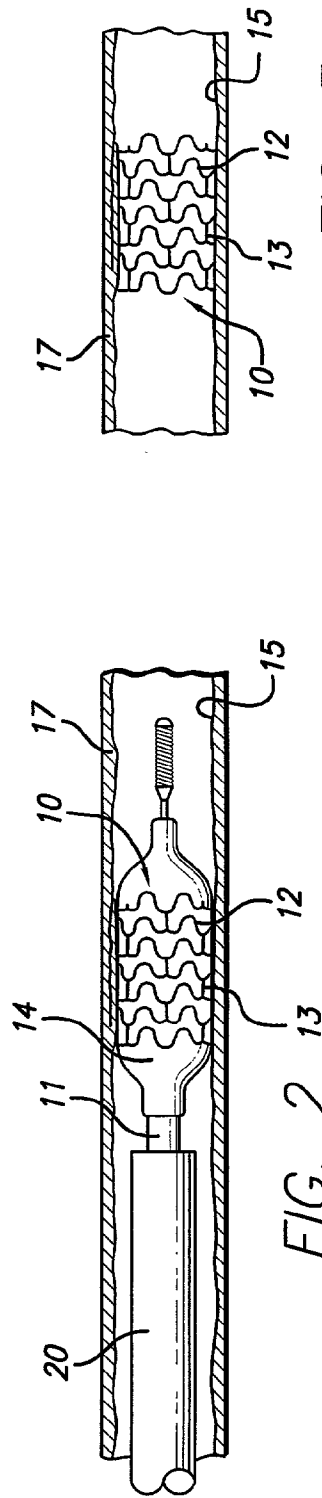

FIG. 3



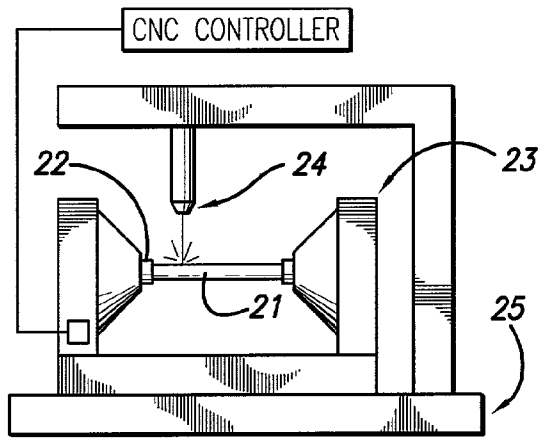
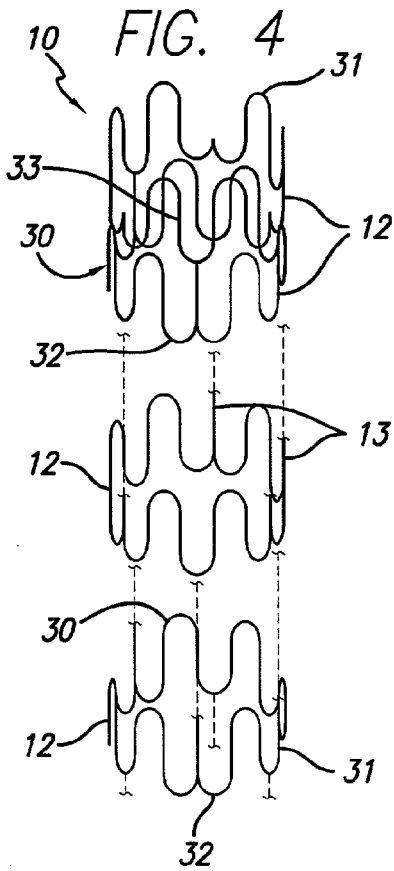

FIG. 6

FIG. 5

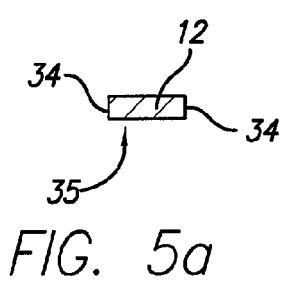
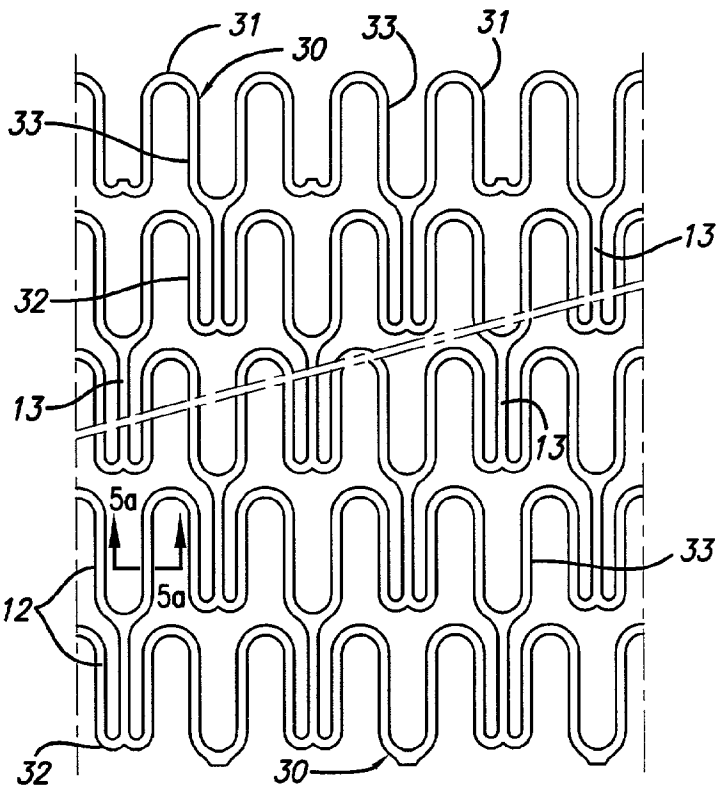

FIG. 5a

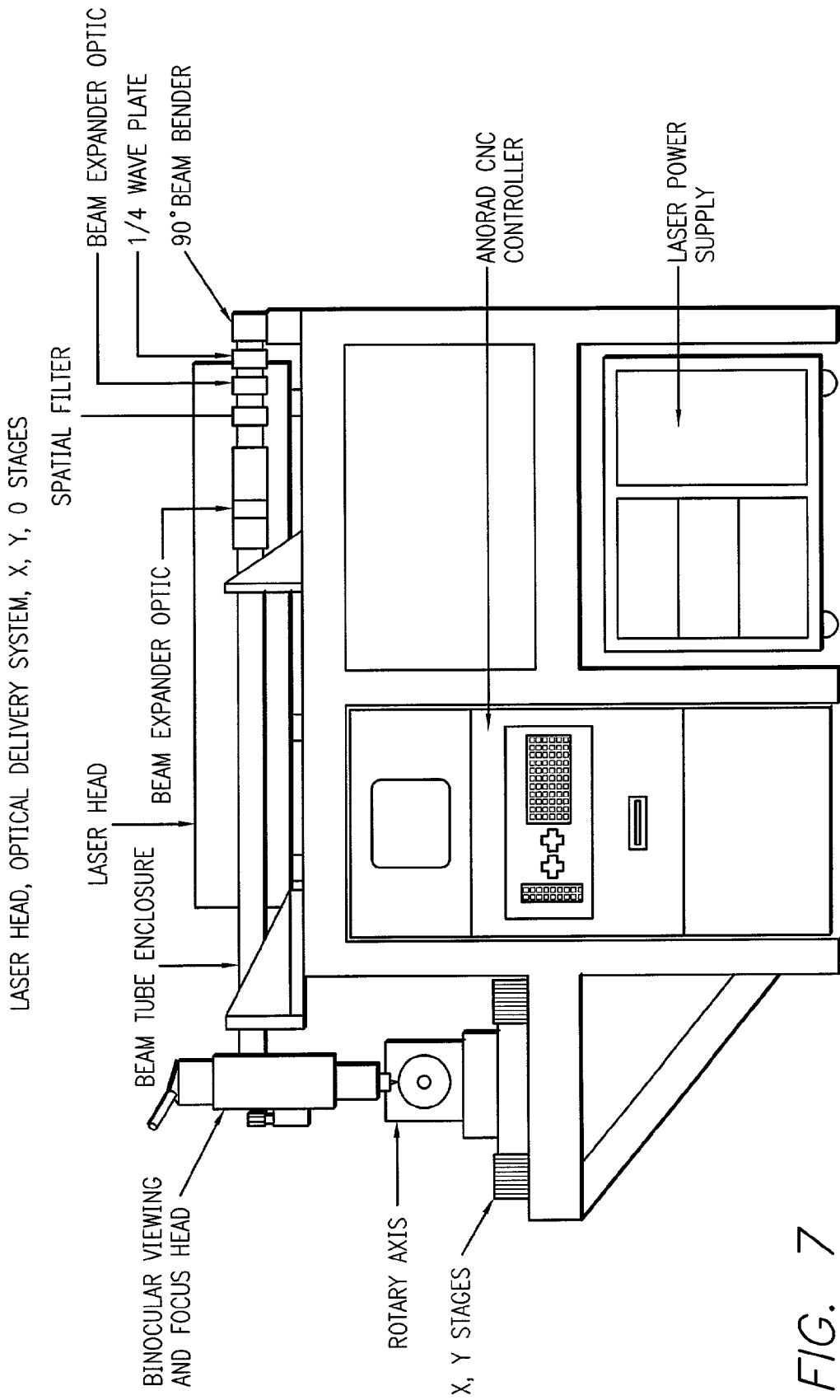
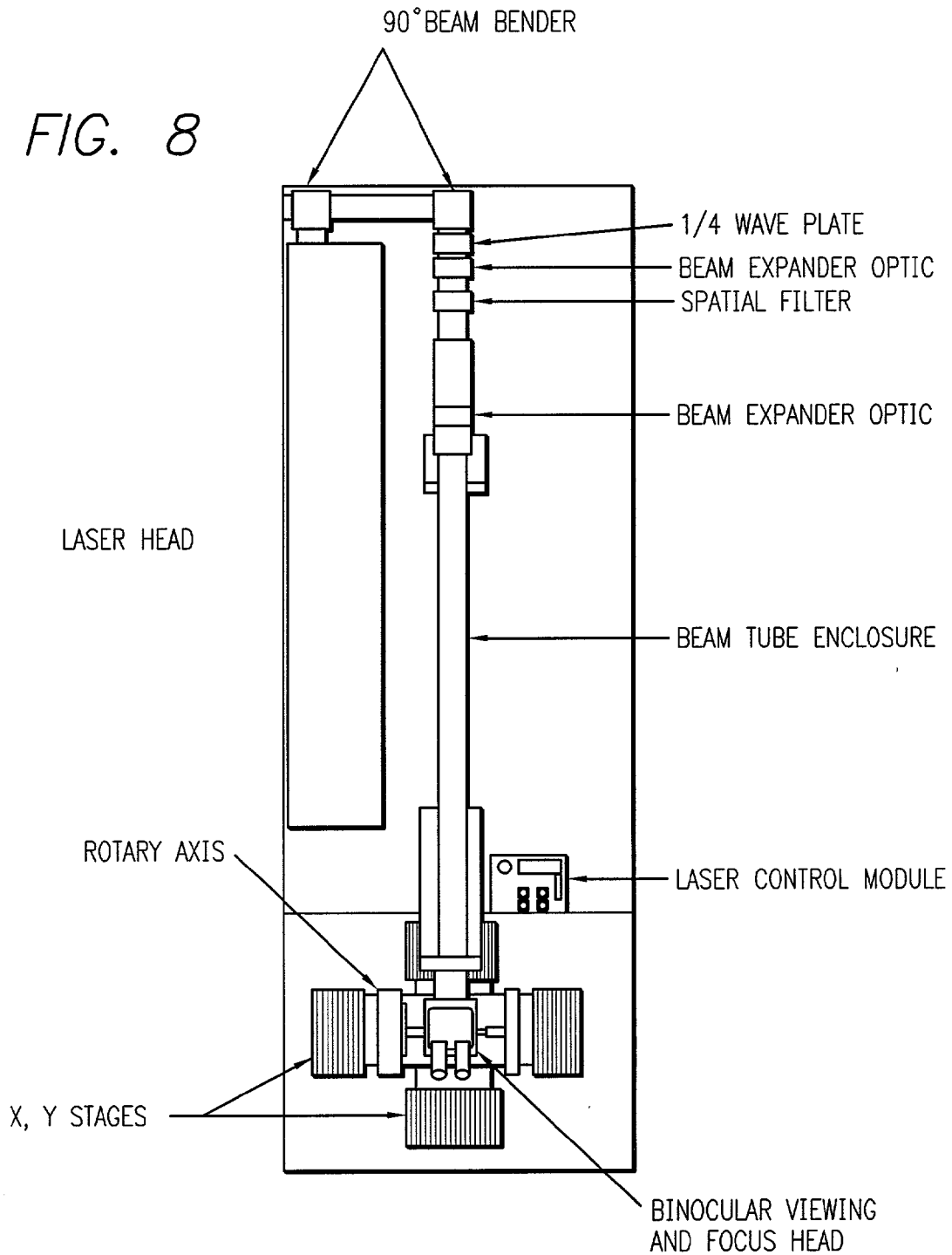

FIG. 7

LASER HEAD, OPTICAL DELIVERY SYSTEM, X, Y, Z STAGES

FIG. 8



COAXIAL GAS JET - ROTARY COLLECT AND
TUBE SUPPORT - TUBE BEAM BLOCK

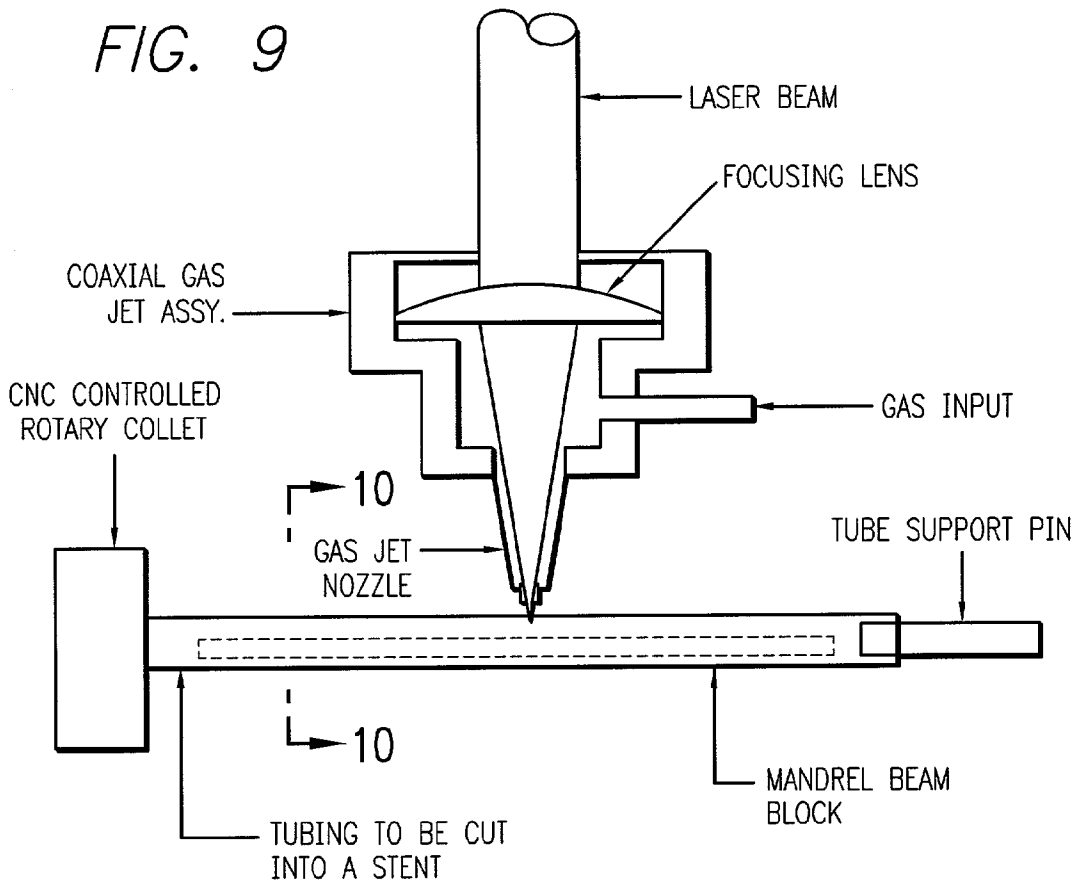
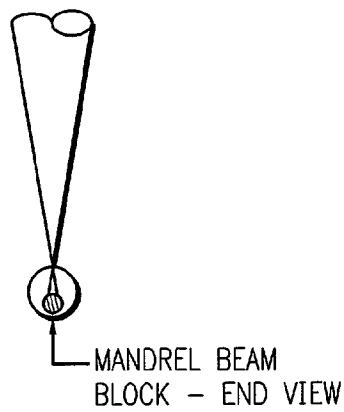
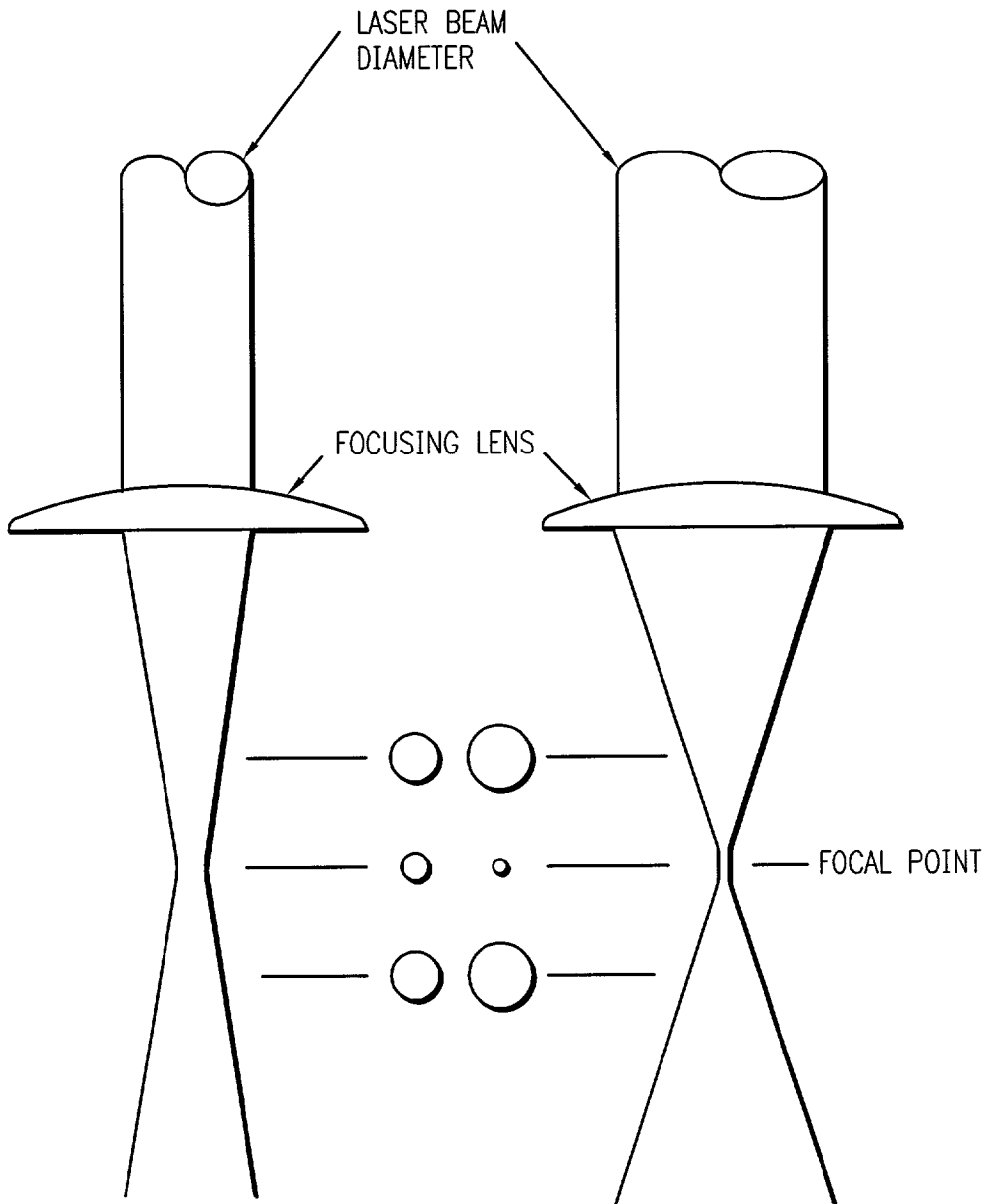

FIG. 10



BEAM DIAMETER VS SPOT SIZE AND DEPTH OF FOCUS

FIG. 11



FOCAL LENGTH VS SPOT SIZE AND DEPTH OF FOCUS

FIG. 12

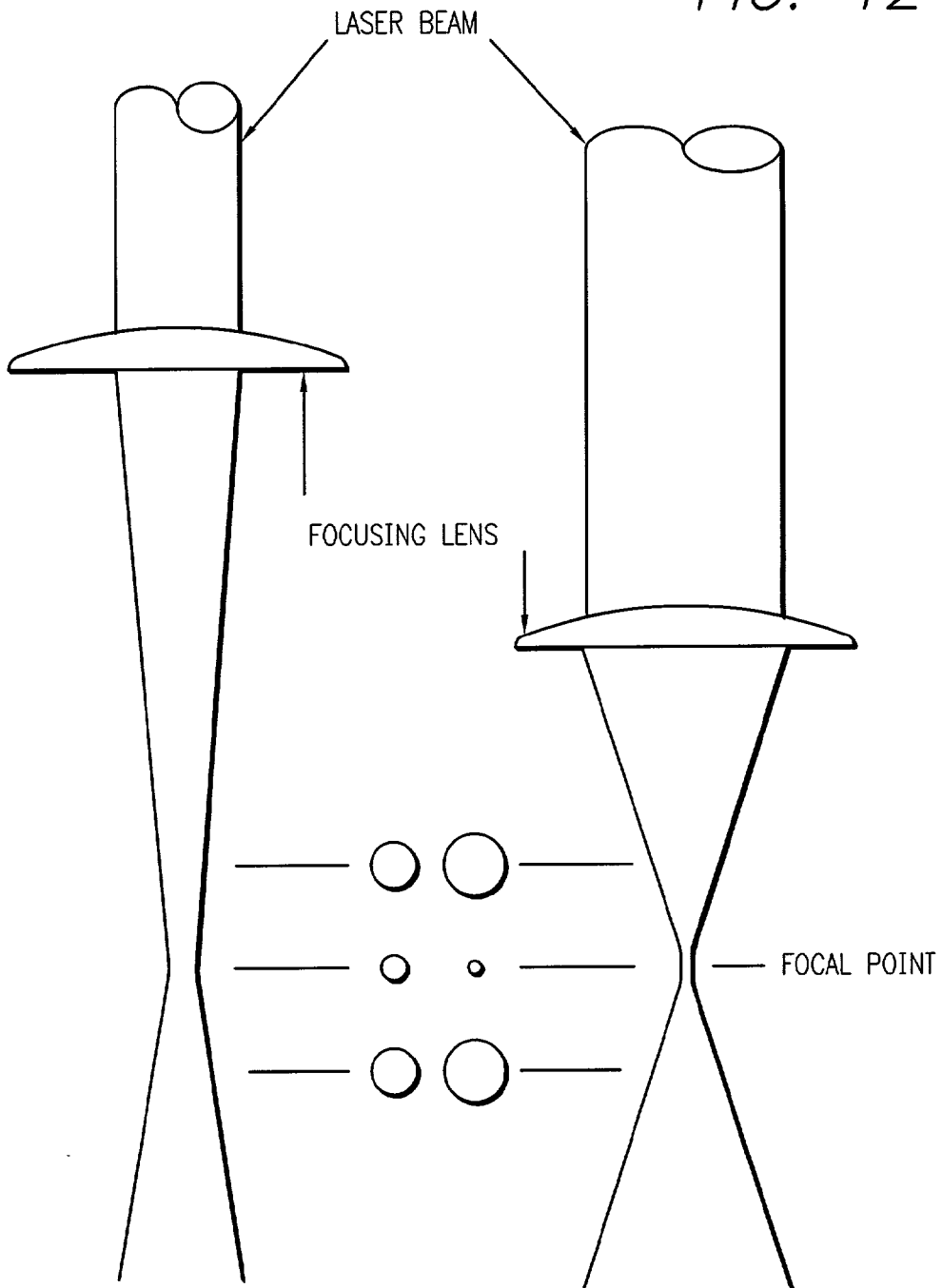

METHOD AND APPARATUS FOR DIRECT LASER CUTTING OF METAL STENTS

BACKGROUND OF THE INVENTION

[0001] This invention relates generally to improvements in the manufacture of expandable metal stents and, more particularly, to new and improved methods and apparatus for direct laser cutting of metal stents and providing stents of enhanced structural quality.

[0002] Stents are expandable endoprosthesis devices which are adapted to be implanted into a patient's body lumen, such as a blood vessel, to maintain the patency of the vessel. These devices are typically used in the treatment of atherosclerotic stenosis in blood vessels and the like.

[0003] In the medical arts, stents are generally tubular-shaped devices which function to hold open a segment of a blood vessel or other anatomical lumen. They are particularly suitable for use to support and hold back a dissected arterial lining which can occlude the fluid passageway.

[0004] Various means have been provided to deliver and implant stents. One method frequently described for delivering a stent to a desired intraluminal location includes mounting the expandable stent on an expandable member, such as a balloon, provided on the distal end of an intravascular catheter, advancing the catheter to the desired location within the patient's body lumen, inflating the balloon on the catheter to expand the stent into a permanent expanded condition and then deflating the balloon and removing the catheter.

[0005] One example of a particularly useful expandable stent is a stent which is relatively flexible along its longitudinal axis to facilitate delivery through tortuous body lumens, but which is stiff and stable enough radially in an expanded condition to maintain the patency of a body lumen such as an artery when implanted within the lumen. Such a desirable stent typically includes a plurality of radially expandable cylindrical elements which are relatively independent in their ability to expand and to flex relative to one another. The individual radially expandable cylindrical elements of the stent are precisely dimensioned so as to be longitudinally shorter than their own diameters. Interconnecting elements or struts extending between adjacent cylindrical elements provide increased stability and a preferable position to prevent warping of the stent when it is expanded. The resulting stent structure is a series of radially expandable cylindrical elements which are spaced longitudinally close enough so that small dissections in the wall of a body lumen may be pressed back into position against the luminal wall, but not so close as to compromise the longitudinal flexibilities of the stent. The individual cylindrical elements may rotate slightly relative to adjacent cylindrical elements without significant deformation, cumulatively giving a stent which is flexible along its length and about its longitudinal axis, but is still very stiff in the radial direction in order to resist collapse.

[0006] The aforescribed stents generally have a precisely layed out circumferential undulating pattern, e.g. serpentine. The transverse cross-section of the undulating component of the cylindrical element is relatively small and preferably has an aspect ratio of about two to one to about 0.5 to one. A one to one aspect ratio has been found particularly

suitable. The open reticulated structure of the stent allows for the perfusion of blood over a large portion of the arterial wall which can improve the healing and repair of a damaged arterial lining.

[0007] The radial expansion of the expandable cylinder deforms the undulating pattern similar to changes in a waveform which result from decreasing the waveform's amplitude and the frequency. Preferably, the undulating patterns of the individual cylindrical structures are in phase with each other in order to prevent the contraction of the stent along its length when it is expanded. The cylindrical structures of the stent are plastically deformed when expanded so that the stent will remain in the expanded condition and, therefore, they must be sufficiently rigid when expanded to prevent their collapse in use. During expansion of the stent, portions of the undulating pattern will tip outwardly resulting in projecting members on the outer surface of the expanded stent. These projecting members tip radially outwardly from the outer surface of the stent and embed in the vessel wall and help secure the expanded stent so that it does not move once it is implanted.

[0008] The elongated elements which interconnect adjacent cylindrical elements should have a precisely defined transverse cross-section similar to the transverse dimensions of the undulating components of the expandable cylindrical elements. The interconnecting elements may be formed as a unitary structure with the expandable cylindrical elements from the same intermediate product, such as a tubular element, or they may be formed independently and connected by suitable means, such as by welding or by mechanically securing the ends of the interconnecting elements to the ends of the expandable cylindrical elements. Preferably, all of the interconnecting elements of a stent are joined at either the peaks or the valleys of the undulating structure of the cylindrical elements which form the stent. In this manner, there is no shortening of the stent upon expansion.

[0009] The number and location of elements interconnecting adjacent cylindrical elements can be varied in order to develop the desired longitudinal flexibility in the stent structure both in the unexpanded, as well as the expanded condition. These properties are important to minimize alteration of the natural physiology of the body lumen into which the stent is implanted and to maintain the compliance of the body lumen which is internally supported by the stent. Generally, the greater the longitudinal flexibility of the stent, the easier and the more safely it can be delivered to the implantation site.

[0010] It will be apparent from the foregoing that conventional stents are very high precision, relatively fragile devices and, ideally, the most desirable metal stents incorporate a fine precision structure cut from a very small diameter, thin-walled cylindrical tube. In this regard, it is extremely important to make precisely dimensioned, smooth, narrow cuts in the stainless tubes in extremely fine geometries without damaging the narrow struts that make up the stent structure. While the various cutting processes, including chemical etching, heretofore utilized by the prior art to form such expandable metal stents, have been adequate, improvements have been sought to provide stents of enhanced structural quality in terms of resolution, reliability and yield.

[0011] Accordingly, those concerned with the development, manufacture and use of metal stents have long rec-

ognized the need for improved manufacturing processes for such stents. The present invention fulfills these needs.

SUMMARY OF THE INVENTION

[0012] Briefly, and in general terms, the present invention provides a new and improved method and apparatus for direct laser cutting of metal stents enabling greater precision, reliability, structural integrity and overall quality, without burrs, slag or other imperfections which might otherwise hamper stent integrity and performance.

[0013] Basically, the present invention provides an improved system for producing metal stents with a fine precision structure cut from a small diameter, thin-walled, cylindrical tube. The tubes are typically made of stainless steel and are fixtured under a laser and positioned utilizing a CNC to generate a very intricate and precise pattern. Due to the thin-wall and the small geometry of the stent pattern, it is necessary to have very precise control of the laser, its power level, the focus spot size, and the precise positioning of the laser cutting path.

[0014] In a presently preferred embodiment of the invention, in order to minimize the heat input, which prevents thermal distortion, uncontrolled burn out of the metal, and metallurgical damage due to excessive heat, a Q-switched Nd/YAG laser that is frequency doubled to produce a green beam at 532 nanometers is utilized. Q-switching produces very short pulses (<100 nS) of high peak powers (kilowatts), low energy per pulse (≤ 3 mJ), at high pulse rates (up to 40 kHz). The frequency doubling of the beam from 1.06 microns to 0.532 microns allows the beam to be focused to a spot size that is 2 times smaller and, therefore, increases the power density by a factor of four. With all of these parameters, it is possible to make smooth, narrow cuts in the stainless tubes in very fine geometries without damaging the narrow struts that make up to stent structure.

[0015] In addition to the laser and the CNC positioning equipment, the optical delivery system utilized in the practice of the present invention, includes a beam expander to increase the laser beam diameter, a circular polarizer to eliminate polarization effects in metal cutting, provisions for a spatial filter, a binocular viewing head and focusing lens, and a coaxial gas jet that provides for the introduction of a gas stream that surrounds the focused beam and is directed along the beam axis. The coaxial gas jet nozzle is centered around the focused beam with approximately 0.010" between the tip of the nozzle and the tubing. The jet is pressurized with oxygen at 20 psi and is directed at the tube with the focused laser beam exiting the tip of the nozzle. The oxygen reacts with the metal to assist in the cutting process very similar to oxyacetylene cutting. The focused laser beam acts as an ignition source and controls the reaction of the oxygen with the metal. In this manner, it is possible to cut the material with a very fine kerf with precision. In order to prevent burning by the beam and/or molten slag on the far wall of the tube inside diameter, a stainless steel mandrel is placed inside the tube and is allowed to toll on the bottom of the tube as the pattern is cut. This acts as a beam/debris block protecting the far wall inside diameter.

[0016] The cutting process utilizing oxygen with the finely focused green beam results in a very narrow kerf (approx. 0.0005") with the molten slag re-solidifying along the cut. This traps the cut out scrap of the pattern and requires further

processing. In order to remove the slag debris from the cut allowing the scrap to be removed from the remaining stent pattern, it is desirable to soak the cut tube in a solution of HCL for a selected time and temperature. Before it is soaked, the tube is placed in a bath of alcohol/water solution and ultrasonically cleaned for approximately 1 minute to remove the loose debris left from the cutting operation. After soaking, the tube is then ultrasonically cleaned in the heated HCL for a period of time dependent upon the wall thickness. To prevent cracking/breaking of the struts attached to the material left at the two ends of the stent pattern due to harmonic oscillations induced by the ultrasonic cleaner, a mandrel is placed down the center of the tube during the cleaning/scrap removal process. At completion of this process, the stent structures are rinsed in water. They are then ready for electropolishing.

[0017] Hence, the new and improved method and apparatus for direct laser cutting of metal stents, in accordance with the present invention, makes accurate, reliable, high resolution, expandable stents with patterns having smooth, narrow cuts and very fine geometries.

[0018] The above and other objects and advantages of this invention will be apparent from the following more detailed description when taken in conjunction with the accompanying drawings of exemplary embodiments.

DESCRIPTION OF THE DRAWINGS

[0019] **FIG. 1** is an elevational view, partially in section, of a stent embodying features of the invention which is mounted on a delivery catheter and disposed within a damaged artery;

[0020] **FIG. 2** is an elevational view, partially in section, similar to that shown in **FIG. 1** wherein the stent is expanded within a damaged artery, pressing the damaged lining against the arterial wall;

[0021] **FIG. 3** is an elevational view, partially in section showing the expanded stent within the artery after withdrawal of the delivery catheter;

[0022] **FIG. 4** is a perspective view of a stent embodying in an unexpanded state, with one end of the stent being shown in an exploded view to illustrate the details thereof;

[0023] **FIG. 5** is a plan view of a flattened section of a stent of the invention which illustrates the undulating pattern of the stent shown in **FIG. 4**;

[0024] **FIG. 5a** is a sectional view taken along the line 5a-5a in **FIG. 5**;

[0025] **FIG. 6** is a schematic representation of equipment for selectively cutting the tubing in the manufacture of stents, in accordance with the present invention;

[0026] **FIG. 7** is an elevational view of a system for cutting an appropriate pattern by laser in a metal tube to form a stent, in accordance with the invention;

[0027] **FIG. 8** is a plan view of the laser head and optical delivery subsystem for the laser cutting system shown in **FIG. 7**;

[0028] **FIG. 9** is an elevational view of a coaxial gas jet, rotary collet, tube support and beam blocking apparatus for use in the system of **FIG. 7**;

[0029] FIG. 10 is a sectional view taken along the line 10-10 in FIG. 9;

[0030] FIG. 11 is an elevational and schematic drawing of laser beam diameter vs. spot size and depth of focus; and

[0031] FIG. 12 is an elevational and schematic drawing of focal length vs. spot size and depth of focus.

DETAILED DESCRIPTION OF THE PREFERRED EMBODIMENTS

[0032] Referring now to the drawings, and particularly FIG. 1 thereof, there is shown a stent 10 which is mounted onto a delivery catheter 11. The stent 10 is a high precision patterned tubular device. The stent 10 typically comprises a plurality of radially expanded cylindrical elements 12 disposed generally coaxially and interconnected by elements 13 disposed between adjacent cylindrical elements. The delivery catheter 11 has an expandable portion or balloon 14 for expanding of the stent 10 within an artery 15. The artery 15, as shown in FIG. 1 has a dissected lining 16 which has occluded a portion of the arterial passageway.

[0033] The typical delivery catheter 11 onto which the stent 10 is mounted, is essentially the same as a conventional balloon dilatation catheter for angioplasty procedures. The balloon 14 may be formed of suitable materials such as polyethylene, polyethylene terephthalate, polyvinyl chloride, nylon and ionomers such as Surlyn® manufactured by the Polymer Products Division of the Du Pont Company. Other polymers may also be used. In order for the stent 10 to remain in place on the balloon 14 during delivery to the site of the damage within the artery 15, the stent 10 is compressed onto the balloon. A retractable protective delivery sleeve 20 as described in copending application Ser. No. 07/647,464 filed on April 25, 1990 and entitled STENT DELIVERY SYSTEM may be provided to further ensure that the stent stays in place on the expandable portion of the delivery catheter 11 and prevent abrasion of the body lumen by the open surface of the stent 20 during delivery to the desired arterial location. Other means for securing the stent 10 onto the balloon 14 may also be used, such as providing collars or ridges on the ends of the working portion, i.e. the cylindrical portion, of the balloon.

[0034] Each radially expandable cylindrical element 12 of the stent 10 may be independently expanded. Therefore, the balloon 14 may be provided with an inflated shape other than cylindrical, e.g. tapered, to facilitate implantation of the stent 10 in a variety of body lumen shapes.

[0035] The delivery of the stent 10 is accomplished in the following manner. The stent 10 is first mounted onto the inflatable balloon 14 on the distal extremity of the delivery catheter 11. The balloon 14 is slightly inflated to secure the stent 10 onto the exterior of the balloon. The catheter-stent assembly is introduced within the patient's vasculature in a conventional Seldinger technique through a guiding catheter (not shown). A guidewire 18 is disposed across the damaged arterial section with the detached or dissected lining 16 and then the catheter-stent assembly is advanced over a guidewire 18 within the artery 15 until the stent 10 is directly under the detached lining 16. The balloon 14 of the catheter is expanded, expanding the stent 10 against the artery 15, which is illustrated in FIG. 2. While not shown in the drawing, the artery 15 is preferably expanded slightly by the

expansion of the stent 10 to seat or otherwise fix the stent 10 to prevent movement. In some circumstances during the treatment of stenotic portions of an artery, the artery may have to be expanded considerably in order to facilitate passage of blood or other fluid therethrough.

[0036] The stent 10 serves to hold open the artery 15 after the catheter 11 is withdrawn, as illustrated by FIG. 3. Due to the formation of the stent 10 from elongated tubular member, the undulating component of the cylindrical elements of the stent 10 is relatively flat in transverse cross-section, so that when the stent is expanded, the cylindrical elements are pressed into the wall of the artery 15 and as a result do not interfere with the blood flow through the artery 15. The cylindrical elements 12 of the stent 10 which are pressed into the wall of the artery 15 will eventually be covered with endothelial cell growth which further minimizes blood flow interference. The undulating portion of the cylindrical sections 12 provide good tacking characteristics to prevent stent movement within the artery. Furthermore, the closely spaced cylindrical elements 12 at regular intervals provide uniform support for the wall of the artery 15, and consequently are well adapted to tack up and hold in place small flaps or dissections in the wall of the artery 15, as illustrated in FIGS. 2 and 3.

[0037] FIG. 4 is an enlarged perspective view of the stent 10 shown in FIG. 1 with one end of the stent shown in an exploded view to illustrate in greater detail the placement of interconnecting elements 13 between adjacent radially expandable cylindrical elements 12. Each pair of the interconnecting elements 13 on one side of a cylindrical element 12 are preferably placed to achieve maximum flexibility for a stent. In the embodiment shown in FIG. 4, the stent 10 has three interconnecting elements 13 between adjacent radially expandable cylindrical elements 12 which are 120° apart. Each pair of interconnecting elements 13 on one side of a cylindrical element 12 are offset radially 60° from the pair on the other side of the cylindrical element. The alternation of the interconnecting elements results in a stent which is longitudinally flexible in essentially all directions. Various configurations for the placement of interconnecting elements are possible. However, as previously mentioned, all of the interconnecting elements of an individual stent should be secured to either the peaks or valleys of the undulating structural elements in order to prevent shortening of the stent during the expansion thereof.

[0038] The number of undulations may also be varied to accommodate placement of interconnecting elements 13, e.g. at the peaks of the undulations or along the sides of the undulations as shown in FIG. 5.

[0039] As best observed in FIGS. 4 and 5, cylindrical elements 12 are in the form of a serpentine pattern 30. As previously mentioned, each cylindrical element 12 is connected by interconnecting elements 13. Serpentine pattern 30 is made up of a plurality of U-shaped members 31, W-shaped members 32, and Y-shaped members 33, each having a different radius so that expansion forces are more evenly distributed over the various members.

[0040] The aforescribed illustrative stent 10 and similar stent structures can be made in many ways. However, the preferred method of making the stent is to cut a thin-walled tubular member, such as stainless steel tubing to remove portions of the tubing in the desired pattern for the stent,

leaving relatively untouched the portions of the metallic tubing which are to form the stent. In accordance with the invention, it is preferred to cut the tubing in the desired pattern by means of a machine-controlled laser as illustrated schematically in FIG. 6.

[0041] The tubing may be made of suitable biocompatible material such as stainless steel. The stainless steel tube may be Alloy type: 316L SS, Special Chemistry per ASTM F138-92 or ASTM F139-92 grade 2. Special Chemistry of type 316L per ASTM F138-92 or ASTM F139-92 Stainless Steel for Surgical Implants in weight percent.

Carbon (C)	0.03% max.
Manganese (Mn)	2.00% max.
Phosphorous (P)	0.025% max.
Sulphur (S)	0.010% max.
Silicon (Si)	0.75% max.
Chromium (Cr)	17.00–19.00%
Nickel (Ni)	13.00–15.50%
Molybdenum (Mo)	2.00–3.00%
Nitrogen (N)	0.10% max.
Copper (Cu)	0.50% max.
Iron (Fe)	Balance

[0042] The stent diameter is very small, so the tubing from which it is made must necessarily also have a small diameter. Typically the stent has an outer diameter on the order of about 0.06 inch in the unexpanded condition, the same outer diameter of the tubing from which it is made, and can be expanded to an outer diameter of 0.1 inch or more. The wall thickness of the tubing is about 0.003 inch.

[0043] Referring to FIG. 6, the tubing 21 is put in a rotatable collet fixture 22 of a machine-controlled apparatus 23 for positioning the tubing 21 relative to a laser 24. According to machine-encoded instructions, the tubing 21 is rotated and moved longitudinally relative to the laser 24 which is also machine-controlled. The laser selectively removes the material from the tubing by ablation and a pattern is cut into the tube. The tube is therefore cut into the discrete pattern of the finished stent.

[0044] The process of cutting a pattern for the stent into the tubing is automated except for loading and unloading the length of tubing. Referring again to FIG. 6 it may be done, for example, using a CNC-opposing collet fixture 22 for axial rotation of the length of tubing, in conjunction with a CNC X/Y table 25 to move the length of tubing axially relative to a machine-controlled laser as described. The entire space between collets can be patterned using the CO₂ laser set-up of the foregoing example. The program for control of the apparatus is dependent on the particular configuration used and the pattern to be ablated in the coating.

[0045] Referring now to FIGS. 7-10 of the drawings, there is shown a process and apparatus, in accordance with the invention, for producing metal stents with a fine precision structure cut from a small diameter thin-walled cylindrical tube. Cutting a fine structure (0.0035" web width) requires minimal heat input and the ability to manipulate the tube with precision. It is also necessary to support the tube yet not allow the stent structure to distort during the cutting operation. In order to successfully achieve the desired end results, the entire system must be configured very carefully. The

tubes are made of stainless steel with an outside diameter of 0.060" to 0.066" and a wall thickness of 0.002" to 0.004". These tubes are fixtured under a laser and positioned utilizing a CNC to generate a very intricate and precise pattern. Due to the thin wall and the small geometry of the stent pattern (0.0035" typical web width), it is necessary to have very precise control of the laser, its power level, the focused spot size, and the precise positioning of the laser cutting path.

[0046] In order to minimize the heat input into the stent structure, which prevents thermal distortion, uncontrolled burn out of the metal, and metallurgical damage due to excessive heat, and thereby produce a smooth debris free cut, a Q-switched Nd/YAG, typically available from Quantronix of Hauppauge, N.Y., that is frequency doubled to produce a green beam at 532 nanometers is utilized. Q-switching produces very short pulses (<100 ns) of high peak powers (kilowatts), low energy per pulse (≤ 3 mJ), at high pulse rates (up to 40 kHz). The frequency doubling of the beam from 1.06 microns to 0.532 microns allows the beam to be focused to a spot size that is 2 times smaller, therefore increasing the power density by a factor of 4 times. With all of these parameters, it is possible to make smooth, narrow cuts in the stainless tubes in very fine geometries without damaging the narrow struts that make up to stent structure. Hence, the system of the present invention makes it possible to adjust the laser parameters to cut narrow kerf width which will minimize the heat input into the material.

[0047] The positioning of the tubular structure requires the use of precision CNC equipment such as that manufactured and sold by Anorad Corporation. In addition, a unique rotary mechanism has been provided that allows the computer program to be written as if the pattern were being cut from a flat sheet. This allows both circular and linear interpolation to be utilized in programming. Since the finished structure of the stent is very small, a precision drive mechanism is required that supports and drives both ends of the tubular structure as it is cut. Since both ends are driven, they must be aligned and precisely synchronized, otherwise the stent structure would twist and distort as it is being cut. A suitable computer program for controlling the CNC equipment is enclosed herewith as Appendix A.

[0048] The optical system which expands the original laser beam, delivers the beam through a viewing head and focuses the beam onto the surface of the tube, incorporates a coaxial gas jet and nozzle that helps to remove debris from the kerf and cools the region where the beam interacts with the material as the beam cuts and vaporizes the metal. It is also necessary to block the beam as it cuts through the top surface of the tube and prevent the beam, along with the molten metal and debris from the cut, from impinging on the opposite surface of the tube.

[0049] In addition to the laser and the CNC positioning equipment, the optical delivery system includes a beam expander to increase the laser beam diameter, a circular polarizer, typically in the form of a quarter wave plate, to eliminate polarization effects in metal cutting, provisions for a spatial filter, a binocular viewing head and focusing lens, and a coaxial gas jet that provides for the introduction of a gas stream that surrounds the focused beam and is directed along the beam axis. The coaxial gas jet nozzle (0.018" I.D.) is centered around the focused beam with approximately

0.010" between the tip of the nozzle and the tubing. The jet is pressurized with oxygen at 20 psi and is directed at the tube with the focused laser beam exiting the tip of the nozzle (0.018" dia.) The oxygen reacts with the metal to assist in the cutting process very similar to oxyacetylene cutting. The focused laser beam acts as an ignition source and controls the reaction of the oxygen with the metal. In this manner, it is possible to cut the material with a very fine kerf with precision. In order to prevent burning by the beam and/or molten slag on the far wall of the tube I.D., a stainless steel mandrel (approx. 0.034" dia.) is placed inside the tube and is allowed to roll on the bottom of the tube as the pattern is cut. This acts as a beam/debris block protecting the far wall I.D.

[0050] Alternatively, this may be accomplished by inserting a second tube inside the stent tube which has an opening to trap the excess energy in the beam which is transmitted through the kerf along which collecting the debris that is ejected from the laser cut kerf. A vacuum or positive pressure can be placed in this shielding tube to remove the collection of debris.

[0051] Another technique that could be utilized to remove the debris from the kerf and cool the surrounding material would be to use the inner beam blocking tube as an internal gas jet. By sealing one end of the tube and making a small hole in the side and placing it directly under the focused laser beam, gas pressure could be applied creating a small jet that would force the debris out of the, laser cut kerf from the inside out. This would eliminate any debris from forming or collecting on the inside of the stent structure. It would place all the debris on the outside. With the use of special protective coatings, the resultant debris can be easily removed.

[0052] In most cases, the gas utilized in the jets may be reactive or non-reactive (inert). In the case of reactive gas, oxygen or compressed air is used. Compressed air is used in this application since it offers more control of the material removed and reduces the thermal effects of the material itself. Inert gas such as argon, helium, or nitrogen can be used to eliminate any oxidation of the cut material. The result is a cut edge with no oxidation, but there is usually a tail of molten material that collects along the exit side of the gas jet that must be mechanically or chemically removed after the cutting operation.

[0053] The cutting process utilizing oxygen with the finely focused green beam results in a very narrow kerf (approx. 0.0005") with the molten slag re-solidifying along the cut. This traps the cut out scrap of the pattern requiring further processing. In order to remove the slag debris from the cut allowing the scrap to be removed from the remaining stent pattern, it is necessary to soak the cut tube in a solution of HCL for approximately 8 minutes at a temperature of approximately 55° C. Before it is soaked, the tube is placed in a bath of alcohol/water solution and ultrasonically cleaned for approximately 1 minute to remove the loose debris left

from the cutting operation. After soaking, the tube is then ultrasonically cleaned in the heated HCL for 1-4 minutes depending upon the wall thickness. To prevent cracking/breaking of the struts attached to the material left at the two ends of the stent pattern due to harmonic oscillations induced by the ultrasonic cleaner, a mandrel is placed down the center of the tube during the cleaning/scrap removal process. At completion of this process, the stent structures are rinsed in water. They are now ready for electropolishing.

[0054] The stents are preferably electrochemically polished in an acidic aqueous solution such as a solution of ELECTRO-GLO #300, sold by the ELECTRO-GLO Co., Inc. in Chicago, Ill., which is a mixture of sulfuric acid, carboxylic acids, phosphates, corrosion inhibitors and a biodegradable surface active agent. The bath temperature is maintained at about 110-135° F. and the current density is about 0.4 to about 1.5 amps per in.². Cathode to anode area should be at least about two to one. The stents may be further treated if desired, for example by applying a biocompatible coating.

[0055] Referring now more particularly to **FIGS. 11 and 12**, it will be apparent that both focused laser spot size and depth of focus can be controlled by selecting beam diameter (**FIG. 11**) and focal length for the focusing lens (**FIG. 12**). It will be apparent from **FIGS. 11 and 12** that increasing laser beam diameter, or reducing lens focal length, reduces spot size at the cost of depth of field.

[0056] Direct laser cutting produces edges which are essentially perpendicular to the axis of the laser cutting beam, in contrast with chemical etching and the like which produce pattern edges which are angled. Hence, the laser cutting process of the present invention essentially provides stent cross-sections, from cut-to-cut, which are square or rectangular, rather than trapezoidal; see **FIG. 5a**. The resulting stent structure provides superior performance.

[0057] It will be apparent from the foregoing that the present invention provides a new and improved method and apparatus for direct laser cutting of metal stents enabling greater precision, reliability, structural integrity and overall quality, without burrs, slag or other imperfections which might otherwise hamper stent integrity and performance. While the invention has been illustrated and described herein in terms of its use as an intravascular stent, it will be apparent to those skilled in the art that the stent can be used in other instances such as to expand prostatic urethras in cases of prostate hyperplasia. Other modifications and improvements may be made without departing from the scope of the invention.

[0058] It will be apparent from the foregoing that, while particular forms of the invention have been illustrated and described, various modifications can be made without departing from the spirit and scope of the invention. Accordingly, it is not intended that the invention be limited, except as by the appended claims.

APPENDIX A

PAGES 1-10

Path: C:\BRONCO\QSY
 File: 152C6048.QSY 11,074 .a.. 9-26-94 1:04:40 pm Page 1

152C6048.QSY
 CUTS 1 STENT
 UNEVEN U DES. W/END CONFIGS.
 0.0048 BAR WIDTH-.060 DIA.
 9/12/94
 PROGRAM 11 DISK 70
 CYCLE TIME = 20 MIN.20 SEC

G69 LINEAR CUT
 0 G69 ROTARY+LIN. CUT
 5 G69 R+L FR CUT (FINGER ENDS)
 0 G69 ROTARY CUT
 00 G69 ROTARY INDEX
 0 G69 SHORT STRAIGHT CUT
 5 G69 LONG SLANT
 0
 Z55 1
 Z.006

→ G68 Z-1 (MIRROR IMAGE OF Z AXIS)

X0 Y0 Z0F300

PROGRAM BODY

K.15 F200
 000 G69 CALL .015" HOLES
 000 G69 CALL CROSS HAIR
 Z-60 F300 G69 START PATTERN
 000 G69 CALL FIRST PATTERN
 Z-180 F300
 000
 Z-300 F300
 000
 X.042
 34
 Z0 F300
 200 R5 G69 MAIN PATTERN
 300 G69 ADDITIONAL PATTERN
 Z-37.8 F300
 X.0512
 000 G69 CALLS END PATTERN
 Z-157.8 F300
 000
 Z-277.8 F300
 000
 X1.2888 F200
 M109
 0 M108 FV4

APPENDIX A

Path: C:\BRONCO\QSY

File: 152C6048.QSY 11,074 .a.. 9-26-94 1:04:40 pm

Page 2

X0 F200
M109
I0 M108 FV4
X0 Y2.5 F300

I0 G69 MAIN PATTERN

Z0 FV5
I00
Z-120 FV5
I00
Z-240 FV5
I00
X.0492 F50
Z-300 FV5
I00
Z-180 FV5
I00
Z-60 FV5
I00
X.0492 F50

I0 G69 ADDITIONAL PATTERN

Z0 FV5
I00
Z-120 FV5
I00
Z-240 FV5
I00

I0 G69 CROSS HAIR SUB

M109 FV1
I M108
I05 Y.005
9
I1 M108
5 Y.005 F100

I0 G69 HOLES

9
075 F3
-.0075 J0 M108
0075 F200
Z180 F300
9
075 F3
-.0075J0M108

Path: C:\BRONCO\QSY

File: 152C6048.QSY 11,074 .a.. 9-26-94 1:04:40 pm

Page 3

0075 Z-180 F500
F200

00 G69 FIRST PATTERN
M109

01 G9X.028937 Z0 FV1
02 X.000780 Z-0.802141 FV2
03 X.001255 Z-4.663876
04 X.001866 Z-4.209330
05 X.002307 Z-3.239121
06 X.002646 Z-2.005352
07 X.002782 Z-0.511842 FV6
08 X.019383 Z0.000000 FV1
09 X.001651 Z0.511842 FV3
10 X.001187 Z0.647442
11 X.002137 Z1.944237
12 X.002171 Z1.684496 FV6
13 X.002510 Z0.324676
14 X.002476 Z-1.166924
15 X.002137 Z-2.526744 FV2
16 X.001459 Z-3.628733
17 X.000814 Z-4.276175
18 X.000034 Z-2.916355
19 X.000678 Z-3.304057
20 X.000882 Z-1.749431
21 X.002001 Z-1.359820 FV6
22 X.001764 Z0.129870
23 X.001866 Z1.166924
24 X.001560 Z1.424755 FV3
25 X.002001 Z0.972118
26 X.001852 Z0.242552
27 X.019467 Z0.000000 FV1
28 X.002462 Z-0.630254 FV3
29 X.002341 Z-1.684496

011 Z3
11 Z-3

30 X-.002103 Z-2.979381 FV2
31 X-.001730 Z-3.951499
32 X-.001255 Z-4.535916
33 X-.000432 Z-4.919798
34 X.000509 Z-4.923617
35 X.001195 Z-4.06609
36 X-.001195 Z-4.06609
37 X-.000509 Z-4.923617
38 X.000432 Z-4.919798
39 X.001255 Z-4.535916
40 X.001730 Z-3.951499
41 X.002103 Z-2.979381

Path: C:\BRONCO\QSY
File: 152C6048.QSY

11,074 .a.. 9-26-94 1:04:40 pm

Page 4

.1 Z-3

. Z3

2 X.002341 Z-1.684496 FV3
3 X.002462 Z-0.630254
4 X.019467 Z0 FV1
5 X.001852 Z0.242552 FV3
5 X.002001 Z0.972118
7 X.001560 Z1.424755
3 X.001866 Z1.166924 FV6
9 X.001764 Z0.129870
0 X.002001 Z-1.35982
1 X.000882 Z-1.749431 FV2
2 X.000678 Z-3.304057
3 X-.000034 Z-2.916355
4 X-.000814 Z-4.276175
5 X-.001459 Z-3.628733
6 X-.002137 Z-2.526744
7 X-.002476 Z-1.166924 FV6
8 X-.002510 Z0.324676
9 X-.002171 Z1.684496
0 X-.002137 Z1.944237 FV3
1 X-.001187 Z0.647442
2 X-.001651 Z0.511842
3 X-.019383 Z0 FV1
4 X-.002782 Z-0.511842 FV6
5 X-.002646 Z-2.005352 FV2
6 X-.002307 Z-3.239121
7 X-.001866 Z-4.20933
8 X-.001255 Z-4.663876
9 X-.000780 Z-0.802141
0 X-.028937 Z0 FV1

RETURN TRIP

1 X-.004643 Z0.324676 FV6
2 X-.002980 Z1.058062
3 X-.002772 Z2.513375 FV2
4 X-.002425 Z3.307876
5 X-.001940 Z4.763189
6 X-.000693 Z11.37703
7 X.002841 Z9.921719
8 X.005405 Z2.513375 FV6
9 X.005682 Z-2.513375
0 X.023615 Z-21.95383 FV2
1 X.006375 Z14.74984
2 X-.005026 Z13.11118
3 X-.001951 Z15.82891
4 X.001951 Z15.82891
5 X.005026 Z13.11118
6 X-.006375 Z14.74984
7 X-.023615 Z-21.95383

Path: C:\BRONCO\QSY
File: 152C6048.QSY

11,074 .a.. 9-26-94 1:04:40 pm

Page 5

3 X-.005682 Z-2.513375 FV6
 3 X-.005405 Z2.513375
 3 X-.002841 Z9.921719 FV2
 1 X.000693 Z11.37703
 2 X.001940 Z4.763189
 3 X.002425 Z3.307876
 1 X.002772 Z2.513375
 5 X.002980 Z1.058062 FV6
 5 X.004643 Z0.324676 GO M108

) G69 MAIN PATTERN

9X.036364 Z0 FV1
 K.000780 Z-0.802141 FV2
 K.001255 Z-4.663876
 K.001866 Z-4.209330

034 Z-3
34 Z3

X.002307 Z-3.239121
 X.002646 Z-2.005352
 X.002782 Z-0.511842 FV6
 X.019383 Z0 FV1
 X.001651 Z0.511842 FV6
 X.001187 Z0.647442
 X.002137 Z1.944237
 X.002171 Z1.684496
 X.002510 Z0.324676
 X.002476 Z-1.166924
 X.002137 Z-2.526744 FV2
 X.001459 Z-3.628733
 X.000814 Z-4.276175
 X.000034 Z-2.916355
 X-.000678 Z-3.304057
 X-.000882 Z-1.749431
 X-.002001 Z-1.359820 FV6
 X-.001764 Z0.129870
 X-.001866 Z1.166924
 X-.001560 Z1.424755
 X-.002001 Z0.972118
 X-.001852 Z0.242552

X-.019467 Z0.000000 FV1
 X-.002462 Z-0.630254 FV6
 X-.002341 Z-1.684496 FV2
 X-.002103 Z-2.979381
 X-.001730 Z-3.951499

004Z3

Path: C:\BRONCO\QSY
File: 152C6048.QSY

11,074 .a.. 9-26-94 1:04:40 pm

Page 6

4Z-3

X-.001255 Z-4.535916
X-.000432 Z-4.919798
X.000509 Z-4.923617
X.001195 Z-4.06609
X-.001195 Z-4.06609
X-.000509 Z-4.923617
X.000432 Z-4.919798
X.001255 Z-4.535916

04 Z-3
4 Z3

X.001730 Z-3.951499
X.002103 Z-2.979381
X.002341 Z-1.684496
X.002462 Z-0.630254 FV6
X.019467 Z0 FV1
X.001852 Z0.242552 FV6
X.002001 Z0.972118
X.001560 Z1.424755
X.001866 Z1.166924
X.001764 Z0.129870
X.002001 Z-1.35982
X.000882 Z-1.749431 FV2
X.000678 Z-3.304057
X-.000034 Z-2.916355
X-.000814 Z-4.276175
X-.001459 Z-3.628733
X-.002137 Z-2.526744
X-.002476 Z-1.166924 FV6
X-.002510 Z0.324676
X-.002171 Z1.684496
X-.002137 Z1.944237
X-.001187 Z0.647442
X-.001651 Z0.511842
X-.019383 Z0 FV1
X-.002782 Z-0.511842 FV6
X-.002646 Z-2.005352 FV2
X-.002307 Z-3.239121

034 Z3
34 Z-3

X-.001866 Z-4.20933
X-.001255 Z-4.663876
X-.000780 Z-0.802141
X-.036364 Z0 FV1

RETURN TRIP

Path: C:\BRONCO\QSY

File: 152C6048.QSY 11,074 .a.. 9-26-94 1:04:40 pm

Page 7

X-.000508 Z0.475555 FV3
X-.000882 Z1.294885
X-.000333 Z2.196338
X.000084 Z1.75898
X.000469 Z1.694045
X.000703 Z1.822006
X.001038 Z1.566085
X.001424 Z0.926282
X.020432 Z0 FV1
X.001965 Z-0.765854 FV6
X.002137 Z-1.879302
X.002510 Z-1.101989
X.002442 Z-0.194806
X.002374 Z0.907183
X.002239 Z2.202068 FV2
X.002001 Z3.239121
X.001560 Z4.728812
X.000746 Z5.246384
X-.000170 Z5.635995
X-.000916 Z5.443099
X-.001391 Z4.665786
X-.001823 Z3.884654
X-.002375 Z3.109251
X-.002714 Z2.267003
X-.002680 Z0.907183 FV6
X-.002884 Z-0.064935
X-.002714 Z-1.165014
X-.002273 Z-2.007262 FV3
X-.001798 Z-1.489690
0 X-.001081 Z-0.529031
1 X-.0018795 Z0.000000 FV1
2 X-.001766 Z0.655082 FV2
3 X-.001391 Z1.489690
4 X-.001187 Z2.396873
5 X-.000950 Z3.498862
6 X-.000101 Z2.188699
7 X.000101 Z2.188699
8 X.000950 Z3.498862
9 X.001187 Z2.396873
0 X.001391 Z1.489690
1 X.001766 Z0.655082
2 X.018795 Z0.000000 FV1
3 X.001081 Z-0.529031 FV3
4 X.001798 Z-1.489690
5 X.002273 Z-2.007262
6 X.002714 Z-1.165014 FV6
7 X.002884 Z-0.064935
8 X.002680 Z0.907183
9 X.002714 Z2.267003 FV2
0 X.002375 Z3.109251
1 X.001823 Z3.884654
2 X.001391 Z4.665786

Path: C:\BRONCO\QSY
File: 152C6048.QSY

11,074 .a.. 9-26-94 1:04:40 pm

Page 8

X.000916 Z5.443099
X.000170 Z5.635995
X-.000746 Z5.246384
X-.001560 Z4.728812
X-.002001 Z3.239121
X-.002239 Z2.202068
X-.002374 Z0.907183 FV6
X-.002442 Z-0.194806
X-.002510 Z-1.101989
X-.002137 Z-1.879302
X-.001965 Z-0.765854
X-.020432 Z0.000000 FV1
X-.001424 Z0.926282 FV3
X-.001038 Z1.566085
X-.000703 Z1.822006
X-.000469 Z1.694045
X-.000084 Z1.75898
X.000333 Z2.196338
X.000882 Z1.294885
X.000508 Z0.475555 M108 G0

0 G69 END PATTERN

109

1 G9X.020432 Z 0 FV1
2 X.001965 Z-.7659 FV8
3 X.002137 Z-1.8793
4 X.002510 Z-1.1020 FV6
5 X.002442 Z-.1948
6 X.002374 Z.9072
7 X.002239 Z 2.2021 FV8
8 X.002001 Z 3.2391
9 X.001560 Z 4.7288
0 X.035000 Z 0 FV1
1 X.005068 Z-1.6024 FV3
2 X.002576 Z-4.1024
3 X.001288 Z-6.5623
4 X-.000572 Z-5.4698
5 X-.003148 Z-8.4760
6 X-.005438 Z-6.0161
7 X-.008014 Z-2.1868
8 X-.019320 Z 10.1184 FV7
9 X-.003148 Z-8.7510

08 Z-4 — Z-7
8 Z4 — Z 7

0 X.005152 Z-13.1246 FV2
1 X0 Z-17.5287
2 X-.005152 Z-13.1246 FV3

Path: C:\BRONCO\QSY

File: 152C6048.QSY 11,074 .a.. 9-26-94 1:04:40 pm

Page 9

008 Z4 FV7
 08 Z-4

23 X.003148 Z-8.7510
 24 X.019320 Z 10.1184
 25 X.008014 Z-2.1868
 26 X.005438 Z-6.0161
 27 X.003148 Z-8.4760
 28 X.000572 Z-5.4698
 29 X-.001288 Z-6.5623
 30 X-.002576 Z-4.1024
 31 X-.005068 Z-1.6024
 32 X-.034424 Z 0 FV1
 33 X-.000916 Z 5.4431 FV2
 34 X-.001391 Z 4.6658
 35 X-.001823 Z 3.8847
 36 X-.002375 Z 3.1093
 37 X-.002714 Z 2.2670
 38 X-.002680 Z.9072 FV6
 39 X-.002884 Z-.0649
 40 X-.002714 Z-1.1650
 41 X-.002273 Z-2.0073 FV2
 42 X-.001798 Z-1.4897
 43 X-.001081 Z-.5290
 44 X-.018795 Z0 FV1
 45 X-.001766 Z .6551 FV3
 46 X-.001391 Z 1.4897
 47 X-.001187 Z 2.3969
 48 X-.000950 Z 3.4989
 49 X-.000101 Z 2.1887
 50 X-.000101 Z 2.1887
 51 X-.000950 Z 3.4989
 52 X-.001187 Z 2.3969
 53 X-.001391 Z 1.4897
 54 X-.001766 Z.6551
 55 X-.018795 Z 0 FV1
 56 X.001081 Z-.5290 FV2
 57 X.001798 Z-1.4897
 58 X.002273 Z-2.0073
 59 X.002714 Z-1.1650 FV6
 60 X.002884 Z-.0649
 61 X.002680 Z.9072
 62 X.002714 Z 2.2670 FV2
 63 X.002375 Z 3.1093
 64 X.001823 Z 3.8847
 65 X.001391 Z 4.6658
 66 X.000916 Z 5.4431
 67 X.000170 Z 5.6360
 68 X-.000746 Z 5.2464
 69 X-.001560 Z 4.7288
 70 X-.002001 Z 3.2391
 71 X-.002239 Z 2.2021

Path: C:\BRONCO\QSY

File: 152C6048.QSY 11,074 .a.. 9-26-94 1:04:40 pm

Page 10

72 X-.002374 Z.9072 FV6
73 X-.002442 Z-.1948
74 X-.002510 Z-1.1020
75 X-.002137 Z-1.8793 FV2
76 X-.001965 Z-.7659
77 X-.020432 Z0 FV1
78 X-.001424 Z.9263
79 X-.001038 Z 1.5661 FV3
80 X-.000703 Z 1.8220
81 X-.000469 Z 1.6940
82 X-.000084 Z 1.7590
83 X.000333 Z 2.1963
84 X.000869 Z 2.7120
85 X.000239 Z 2.2804
86 X0 Z 4.3086
87 X-.000239 Z 2.2804
88 X-.000869 Z 2.7120
89 X-.000333 Z 2.1963
90 X.000084 Z 1.7590
91 X.000469 Z 1.6940
92 X.000703 Z 1.8220
93 X.001038 Z 1.5661
94 X.001424 Z.9263G0
3

001
F300
Y2.5 Z0

1. A longitudinal flexible stent for implanting in a body lumen, comprising:

a plurality of cut cylindrical elements which are independently expandable in the radial direction and which are interconnected so as to be generally aligned on a common longitudinal axis, each cylindrical element having a rectangular cross-section from one cut edge to another; and

a plurality of connecting elements for interconnecting said cut cylindrical elements, said connecting elements configured to interconnect said cylindrical elements that are adjacent to each other.

2. The stent of claim 1, wherein said plurality of cut cylindrical elements include a plurality of peaks and valleys having a serpentine pattern.

3. The stent of claim 2, wherein said plurality of peaks and valleys include a plurality of U-shaped members, a plurality of Y-shaped members, and a plurality of W-shaped members, some of said U-shaped, Y-shaped, and W-shaped members being interconnected.

4. The stent of claim 1, wherein at least some of said plurality of cut cylindrical elements tip radially outwardly to form outwardly projecting edges upon radial expansion of said stent.

5. The stent of claim 1, wherein said cut cylindrical elements are capable of retaining their expanded condition upon the expansion thereof.

6. The stent of claim 1, wherein said stent is formed of stainless steel.

7. The stent of claim 1, wherein said stent is formed from a single piece of tubing.

8. A method of making an expandable metal stent, comprising the steps of:

supporting a metal tube for controlled linear and rotary motion;

impinging a finely focused laser beam upon the working surface of said metal tube; and

providing a protective mandrel within said tube to protect the tube wall opposite the tube wall being cut from being ablated by said laser beam,

whereby a precise pattern is cut into said tube to form said stent.

9. A method as set forth in claim 8, wherein said metal tube is stainless steel.

10. A method as set forth in claim 8, wherein said protective mandrel is stainless steel.

11. A method as set forth in claim 8, wherein said laser beam is circularly polarized.

12. A method as set forth in claim 11, wherein said circular polarization is accomplished by a quarter wave plate.

13. A method as set forth in claim 8, wherein said laser beam is spatially filtered.

14. A method as set forth in claim 8, wherein the size of the focused laser beam spot and depth of field is controlled by selecting beam diameter.

15. A method as set forth in claim 8, wherein the size of the focused laser beam spot and depth of field is controlled by selecting focal length of the beam focusing lens.

16. A method as set forth in claim 8, wherein said laser beam passes through a coaxial gas jet adjacent said tube.

17. A method as set forth in claim 16 wherein the gas is oxygen.

18. A method as set forth in claim 8 and further including the steps of:

ultrasonically cleaning said stent after it is formed.

19. A method as set forth in either of claim 1 or 18, and further including the step of electro-polishing said stent after it is formed.

* * * * *