

Sept. 6, 1960

G. MÖHRING  
MACHINE FOR THE TIGHTENING AND DRYING OF  
CURRENT STRIPS OF TEXTILE MATERIAL  
Filed Nov. 26, 1956

2,951,275

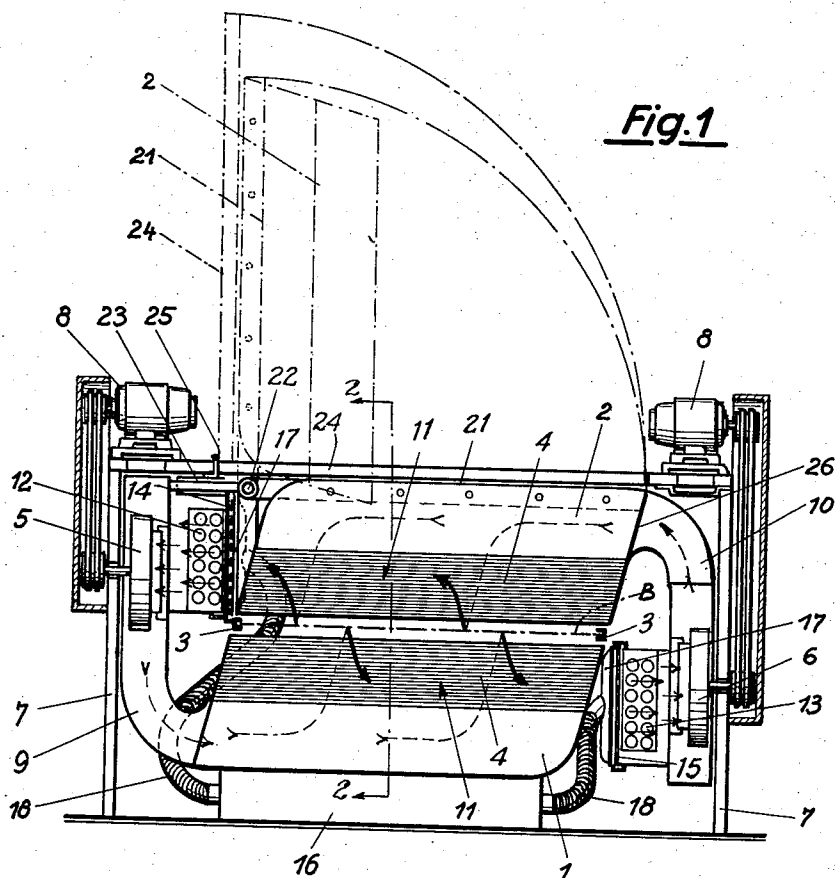

Fig. 1

Fig. 2

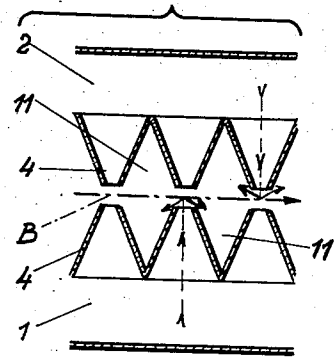

Fig. 3

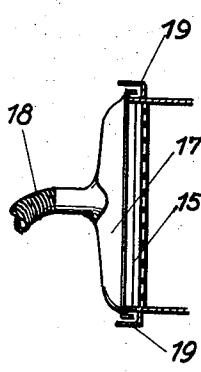
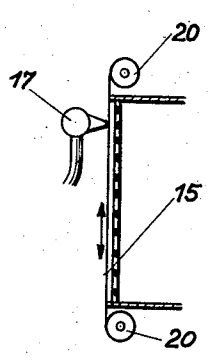

Fig. 4



INVENTOR:  
Gustav Möhring  
by Michael S. Stoker  
Pat.

1

2,951,275

## MACHINE FOR THE TIGHTENING AND DRYING OF CURRENT STRIPS OF TEXTILE MATERIAL

Gustav Möhring, Stuttgart, Germany, assignor to Fama-  
tex G.m.b.H., Stuttgart-Kornwestheim, Germany, a  
firm

Filed Nov. 26, 1956, Ser. No. 624,450

5 Claims. (Cl. 26—60)

This invention relates to a device for the tightening and drying of current strips of textile material, such as knitted fabric and the like, and is particularly directed to a machine, in which the guidance of the drying agent or drying means is so effected that, compared with known machines of this type, an improved drying effect within a smaller space is obtained, and that in addition thereto the machine is so devised that it provides special advantages regarding its accessibility as well as the possibility of cleaning the machine, so that the cleaning of the machine is thereby facilitated and its cost of maintenance considerably reduced.

The tightening and drying machine of the invention is provided with nozzles adapted for blowing the drying means onto the strip of textile material, and, furthermore, is equipped on the suction side of the blowers with heating elements and with filters for cleaning the drying means and arranged before the heating elements.

According to the invention the filters of the machine are provided with a self-cleaning contrivance operating with suction air. By means of this self-cleaning contrivance the sediments of impurities carried by the drying means, such as dust, fibres etc., are constantly drawn off or sucked off the filters.

Furthermore, the machine of the invention is so devised that its upper part as well as its upper nozzle box can be pivoted by means of hinges in upward direction, that is to say, in a direction transverse to the travelling direction of the textile strip.

Such a construction permits not only a profitable utilization of the available space and simplifies the maintenance of the machine at reduced cost, but also permits the cleaning of the machine and the removal of disturbing sediments etc. without difficulty, since after the pivoting of the upper part all essential parts of the machine are easily accessible.

Additional features and advantages of the machine will be understood from a consideration of the following detailed description taken in connection with the accompanying drawing, forming a part of this specification and in which an embodiment of the invention has been shown by way of example. However, I wish to say that the invention is not confined to any strict conformity with the showing of the drawing but may be changed or modified, so long as such changes or modifications mark no material departure from the salient features of the invention as expressed in the appending claims.

In the drawing, in which like parts are referred to by the same reference numerals in all of the several figures,

Fig. 1 is an end view of the machine seen in the travelling direction of the strip of textile material;

Fig. 2 is a cross-section through the drying nozzles of the machine taken along line 2—2 of Fig. 1;

Fig. 3 is a detail-view of a filter provided with a movable dust-removing suction element;

Fig. 4 is a detail-view of a movable filter and of a

2

dust-removing suction element stationarily arranged before the movable filter.

Referring now to the drawing in detail, the reference numerals 1 and 2 designate the two nozzle boxes of the machine, which nozzle boxes are positioned above and below the strip of fabric B moving through the machine by tightening chains 3. The nozzle boxes 1 and 2 are each provided with a plurality of elongated nozzles 4 arranged side by side and being preferably of triangular cross-section, which is to say, that they are tapering in the direction toward the strip of fabric. The nozzles 4 have their openings, respectively, located closely above or below the strip, whereby the upper and lower nozzles 4 are oppositely positioned.

The circulation of the drying means is effected, for example, by two blowers 5 and 6, rotatably secured to the machine frame 7 at both sides of the strip and actuated by means of motors 8. In order to obtain the aforesaid circulation of the drying means, the blowers 5 and 6 are connected by means of channels 9 and 10 with the lower and upper nozzle boxes 1 and 2 in such manner that the pressure side of the blower 5 on the left opens into the lower nozzle box 1 and that the pressure side of the blower 6 on the right opens into the upper nozzle box 2, while the suction sides of the two blowers are each in communication with the spaces 11 formed between the nozzles 4 and the strip B.

For the continuous heating of the drying means, for example ordinary air, two heating elements 12 and 13 are provided, while the removal of dust, etc. is effected by two filters 14 and 15, the construction being preferably so devised that each of the blowers forms with its appertaining heating element and filter an operating unit, and whereby the heating element and the filter are positioned between the suction side of the blowers 5 and 6 and the outlets at the spaces 11.

In order to obtain a compact structure and to utilize the available space in the best possible manner, the nozzle boxes 1 and 2 are so devised that their lateral end walls extend in a direction inclined to the vertical. In this way sufficient space is provided on the left side and right side of the nozzle boxes (on one side above and on the other side below) for the accommodation of the filters 14 or 15, of the heating elements 12 or 13, and of the blowers 5 or 6.

As a result of this arrangement the circulation of the drying means will be as follows: Starting from the blower 5 on the left, the drying means passes from the pressure side of this blower via the channel 9 into the interior of the nozzle box 1, and from there through the nozzles 4 against the moving strip B. As shown by the arrows in Figs. 1 and 2, the drying means is then deflected by the strip and gathers, in the form of whirling currents, in the spaces 11 between the nozzles and the strip, from where it is drawn off by the blower 6 on the right via the filter 15 and the heating element 13 and thus simultaneously cleaned and reheated. From this blower 6 the drying means passes again under pressure, via the channel 10 into the interior of the upper nozzle box 2 provided with the nozzles 4 and, after its passage through the nozzles and its deflection by the strip, gathers in the upper spaces 11, from where it is drawn off by the blower 5 via the filter 14 and the heating element 12, to thus complete the cycle of flow of the drying means.

As already mentioned, the filters 14 and 15 are provided with an automatically working cleaning contrivance consisting of a vacuum chamber 16 or the like (see Fig. 1) for the collection of the impurities and of two suction members 17 movably secured to the filters 14 and 15 (see Fig. 3) and in communication via the hoses or tubes 18 with the collecting chamber 16. The suction members 17 are of approximately the same width as the

filters 14 and 15 and guided in guiding means 19 in such manner that they can be moved to and fro directly before the filters by actuating means provided at the machine, whereby the filters may be devised as textile or metal filters, and whereby sediments of impurities, such as dust, fibres or the like, are drawn off into the collecting chamber 16, from where they can be removed either continuously or at predetermined intervals. The actuating means of the filter-cleaning contrivance are so devised that they can be switched into or out of action independently from the rest of the machine.

Instead of using a movable suction member 17 it is also possible to employ a stationary suction member, in which case the filter 15 must be caused to perform a reciprocating movement before the suction member, as shown in Fig. 4 of the drawing. Also in this case textile filters or metal filters are used. These filters are guided in the form of a band over rollers 20, or the band is rolled off or onto the rollers. The cleaning of the filters may be effected either continuously or at predetermined intervals.

In order to enable at any time a control of the strip B or necessary repairs, or cleaning operations at predetermined intervals, the machine is so devised that the upper part 21 of the machine including the upper nozzle box 2 and the nozzles 4 can be opened with the aid of hinges. The upper part 21 is normally covered up by a hinged cover 24. For this purpose the cover 24 is pivotable in upward direction about a hinge 25, while the upper part 21 can be pivoted in upward direction about a hinge 22 provided at the machine frame 7 above the filter 14 on the left side of the machine, this upward pivotal movement being facilitated by a balance weight 23 provided on the upper part 21 of the machine. The two end positions of the cover 24 and of the upper part 21 are respectively shown in Fig. 1 in full lines and in dot-and-dash lines.

The parting line 26 between the upper nozzle box 2 and the supply channel 10 for the drying means is inclined, so that lowering of the upper part into working position automatically results in sealing of the parting line 26, whereby losses of pressure are reliably avoided in the simplest manner.

The aforesaid construction permits quick and easy access to all important parts of the machine, even in cases where a plurality of machine units of the aforesaid kind are assembled to a large plant, which in this case is particularly simple as every unit works independently of the other units.

What I claim as new and desire to secure by Letters Patent of the United States is:

1. A machine for tightening and drying a moving strip of textile material, comprising, an outer framework; a pair of elongated nozzle boxes each provided with a plurality of nozzles aligned laterally beside one another, said pair of nozzle boxes being horizontally arranged above each other and parallel to each other and suitably spaced apart within said outer frame-work in such manner that the nozzles of one nozzle box confront the nozzles of the other nozzle box, the upper one of said pair of nozzle boxes being pivotally rotatably supported in the machine for movement in upward direction by means of hinges extending in the travelling direction of said strip of textile material; feeding means adapted to feed the strip of textile material in tightened condition through the machine between said plurality of confronting nozzles of said pair of nozzle boxes, said feeding means being located outside the space between said confronting nozzles so that upon pivotal movement of said upper nozzle box, the nozzles on the lower nozzle box become accessible; a blower for each of said nozzle boxes and connected on its pressure side by means of a channel with the interior of the appertaining nozzle box for blowing drying air via the nozzle box and its nozzles into the space between said pair of nozzle boxes and onto

the moving strip of textile material; a heating element arranged before the suction side of each of said blowers; and a filter adapted to remove impurities from the drying air arranged before each of said heating elements on the side turned away from the appertaining blower.

2. A machine as specified in claim 1, including a balancing weight connected to said upper nozzle box and extending from said hinges in opposite direction to said upper box so as to balance said nozzle box about said hinges.

3. A machine as specified in claim 1, in which the channel connecting one of the two blowers with the interior of the upper one of said pair of nozzle boxes is provided at its free end with an inclined edge adapted to loosely but snugly rest against the upper nozzle box and to permit its movement in upward and downward directions.

4. A machine as specified in claim 1, in which the channel connecting one of the two blowers with the interior of the upper one of said pair of nozzle boxes is provided at its free end with an inclined edge adapted to loosely but snugly rest against the upper nozzle box and to permit its movement in upward and downward directions; and including a pivotable cover provided in the framework of the machine above the upper nozzle box and permitting when pivoted into open position the movement of the upper nozzle box in upward and downward directions.

5. A machine for drying a moving strip of textile material comprising, in combination, a housing; a pair of elongated nozzle boxes each having a plurality of elongated nozzles arranged adjacent to each other in a direction transverse to the longitudinal direction of said boxes, each of said nozzles extending substantially along the whole length of the respective box and the nozzles on each box forming between themselves channels extending in the longitudinal direction of said boxes, respectively, said pair of nozzles boxes being mounted in said housing in substantially horizontal position one above the other and substantially parallel to each other and spaced apart in such a manner that the nozzles of one box confront and are spaced from the nozzles of the other box, the upper one of the pair of nozzle boxes being pivotally supported in the machine for pivotal movement in an upward direction by means of hinges extending in a direction transverse to the longitudinal direction of said box; feeding means for feeding a strip of textile material in tightened condition between said plurality of confronting nozzles of said pair of nozzle boxes in a direction transverse to the longitudinal direction of said boxes, said feeding means being located outside the space between said confronting nozzles, so that upon pivotal movement of said upper nozzle box, the nozzles on the lower nozzle box become also accessible; a first blower arranged at one lateral end of the upper box and a second blower arranged at the lateral end of the lower box located on the opposite side of said one lateral end of the upper box; conduit means connecting the pressure side of said first blower with the interior of said lower box and for connecting the pressure side of said second blower with the interior of said upper box so that drying air may be blown through said conduit means via the respective box and the nozzles thereof onto the strip of textile material moving between the confronting nozzles of said pair of nozzle boxes, the suction side of said first blower being located adjacent and facing said one lateral end of said upper box and the suction side of said second blower being located adjacent and facing said lateral end of said lower box so that the air blown onto opposite faces of said strip of textile material and deflected into said channels is sucked from said channels directly into the respective blower; a heating element arranged before the suction side of each of said blowers; and filter means arranged before each of said heating elements on the

2,951,278

5

side turned away from the appertaining blower for removing impurities from the air emanating from the channels before the same enters into said heating elements.

1,830,097  
2,083,141  
2,265,071  
2,495,163

References Cited in the file of this patent 5

UNITED STATES PATENTS

1,510,911 Zehfus ----- Oct. 7, 1924 727,058

6

Dollinger ----- Nov. 3, 1931  
Buck ----- June 8, 1937  
Hartenback ----- Dec. 2, 1941  
Dungler ----- Jan. 17, 1950

FOREIGN PATENTS

Great Britain ----- Mar. 30, 1955