



(11) **EP 3 392 113 B1**

(12) **EUROPEAN PATENT SPECIFICATION**

(45) Date of publication and mention of the grant of the patent:  
**11.11.2020 Bulletin 2020/46**

(51) Int Cl.:  
**B61D 3/18 (2006.01) B61D 47/00 (2006.01)**

(21) Application number: **16874740.0**

(86) International application number:  
**PCT/CN2016/108327**

(22) Date of filing: **02.12.2016**

(87) International publication number:  
**WO 2017/101683 (22.06.2017 Gazette 2017/25)**

(54) **RAILWAY WAGON FOR TRANSPORTING TRUCKS AND METHOD FOR LOADING AND UNLOADING TRUCK**

EISENBahnWAGEN ZUM TRANSPORTIEREN VON LASTKRAFTWAGEN UND VERFAHREN ZUM BE- UND ENTLADEN VON LASTKRAFTWAGEN

WAGON FERROVIAIRE POUR LE TRANSPORT DE CAMIONS, ET PROCÉDÉ DE CHARGEMENT ET DE DÉCHARGEMENT DE CAMION

(84) Designated Contracting States:  
**AL AT BE BG CH CY CZ DE DK EE ES FI FR GB GR HR HU IE IS IT LI LT LU LV MC MK MT NL NO PL PT RO RS SE SI SK SM TR**

- **HAN, Dongwei**  
**Beijing 100072 (CN)**
- **YIN, Xun**  
**Beijing 100072 (CN)**
- **ZHANG, Zhong**  
**Beijing 100072 (CN)**
- **DAI, Anguo**  
**Beijing 100072 (CN)**

(30) Priority: **17.12.2015 CN 201510954098**

(43) Date of publication of application:  
**24.10.2018 Bulletin 2018/43**

(73) Proprietor: **CRRC Qiqihar Rolling Stock Co., Ltd. Qiqihar, Heilongjiang 161002 (CN)**

(74) Representative: **Epping - Hermann - Fischer Patentanwaltsgesellschaft mbH Schloßschmidstraße 5 80639 München (DE)**

(72) Inventors:

- **YU, Jiangang**  
**Beijing 100072 (CN)**
- **ZHANG, Shiyong**  
**Beijing 100072 (CN)**
- **YIN, Li**  
**Beijing 100072 (CN)**

(56) References cited:  
**CN-A- 104 386 075 CN-A- 104 386 075**  
**CN-A- 105 480 236 CN-U- 204 323 346**  
**CN-U- 205 327 063 DE-A1- 10 104 005**  
**GB-A- 1 459 360 JP-A- H01 269 662**  
**US-A- 1 862 938 US-A- 5 032 044**

**EP 3 392 113 B1**

Note: Within nine months of the publication of the mention of the grant of the European patent in the European Patent Bulletin, any person may give notice to the European Patent Office of opposition to that patent, in accordance with the Implementing Regulations. Notice of opposition shall not be deemed to have been filed until the opposition fee has been paid. (Art. 99(1) European Patent Convention).

**Description****FIELD**

[0001] The present application relates to the technical field of railway transportation, and in particular to a railway wagon for transporting trucks and a method for loading and unloading trucks.

**BACKGROUND**

[0002] A long-distance transportation of commercial heavy-duty trucks is mainly by transported by roads and railways. In the road transportation, two trucks even three trucks supporting-transport mode is mostly adopted due to factors such as fuel consumption and work force consumption of the road transportation. That is, one truck transports one or two trucks. This transportation mode may cause an over-limit and over-load problem, which is not safe and may cause a traffic accident. Meanwhile, under the limit of the transportation mode, the losses of the trucks caused by the long-distance driving may be an unnegligible problem when the products are transported to the customer. In another aspect, since the railway transportation has dedicated transportation tracks, losses of trucks during the railway transportation may be omitted. In addition, the railway transportation is not affected by factors such as traffic jam. In this case, goods can be transported to a destination rapidly and on time. However, the shape and size of the commercial heavy-duty truck is substantially fixed, and the trucks may go beyond the gauge of the railway when being loaded on the existing railway wagon for transportation. Therefore, a piggyback transportation mode is mostly adopted, in which a truck full of goods is transported for a long distance by a dedicated railway vehicle on the railway. A piggyback flat car of the dedicated railway vehicle has features of low floor loading surface and large concentrated load bearing, and one railway wagon can be loaded with one truck.

[0003] CN104386075A discloses a wagon for transporting commercial trucks and a loading method for the wagon. The wagon comprises a wagon body, four lifting gears, four bridge plate devices and four cab apron devices, wherein the wagon body comprises a spliced middle beam; the middle section of the middle beam is connected with the lower concave bottom of the wagon body; two sides of the lower concave bottom are respectively provided with a guiding device; two ends of the middle section of the middle beam are respectively connected with an articulated beam; each articulated beam is connected with a slope of the wagon body; the other end of each articulated beam is connected with a towing beam; each towing beam is connected with an end part platform of the wagon body; two sides of the tops of the middle beam and the towing beams are respectively provided with a plurality of fastening seats; two sides of each slope are respectively provided with a bridge plate device; two

sides of the end parts of the wagon body are respectively connected with a cab apron device; two sides of tops of two side walls of the wagon body are oppositely provided with a lifting gear; each lifting gear is hinged to a moving arm; the end part of each moving arm is provided with a connecting hole for lapping another moving arm. The wagon can be widely applied to transportation of various vehicles.

**10 TECHNICAL PROBLEM**

[0004] In view of the above, a railway wagon, capable of fully utilizing space, that a loading truck can be normally driven into and out of, and a method for loading and unloading trucks, are provided according to the present application.

**SOLUTIONS FOR THE PROBLEM****20 TECHNICAL SOLUTIONS**

[0005] In order to achieve the above object, following technical solutions are adopted according to the present application. A railway wagon for transporting trucks includes a running plate device mounted relatively at a middle portion between two side wall assemblies of the railway wagon, wherein, the running plate device includes a middle running plate device, two ends of the middle running plate device are respectively provided with end running plate devices, and an outer end of each of the end running plate devices is provided with a bridge plate device; the middle running plate device includes multiple middle running plate assemblies arranged side by side, each of the middle running plate assemblies includes a first running plate rotatably connected with the side wall assembly, and at least one first support plate rotatably connected with the side wall assembly is arranged below the first running plate; the end running plate device includes multiple end running plate assemblies arranged side by side, each of the end running plate assemblies include a second running plate rotatably connected with the side wall assembly, and at least one second support plate rotatably connected with the side wall assembly is arranged below the second running plate; and the bridge plate device includes a bridge plate, one end of the bridge plate is connected with the second running plate via a connection plate, the other end of the bridge plate is rotatably connected with an underframe assembly of the railway wagon, and a bottom portion of the end of the bridge plate close to the connection plate is provided with a foldable support mechanism.

[0006] Two ends of the first running plate are each provided with a first pneumatic rod rotatably connected to the side wall assembly.

[0007] Two ends of the second running plate are each provided with a second pneumatic rod, a piston rod of the second pneumatic rod is rotatably connected to the side wall assembly, and a pressure tube of the second

pneumatic rod is securely connected with the second running plate via a connection member.

[0008] A bottom portion of the bridge plate is provided with multiple third pneumatic rods rotatably connected with the underframe assembly.

[0009] The middle running plate assemblies located at the two ends of the middle running plate device are arranged tiltedly, and the middle running plate assemblies located at the middle of the middle running plate device are arranged horizontally.

[0010] The foldable support mechanism includes two supports both having a right-angled triangle shape, the two supports are arranged against each other and are rotatably connected with each other, and the two supports are respectively rotatably connected with the bridge plate and the underframe assembly.

[0011] A second connection plate is arranged between the end running plate assembly and the middle running plate assembly.

[0012] A method for loading and unloading trucks is provided.

[0013] The method for loading the trucks includes: step 1, placing horizontally the first running plate of each of the middle running plate assemblies and opening the first support plate to support and fix the first running plate, flipping down the second running plate of each of the end running plate assemblies to placing the second running plate horizontally and opening the second support plate to support and fix the second running plate, supporting the bridge plate device with the foldable support mechanism and connecting the bridge plate device with the second running plate via the connection plate; step 2, driving a first truck into the railway wagon from the bridge plate device at one end of the railway wagon to the bridge plate device at the other end of the railway wagon and stopping the first truck at the bridge plate device at the other end of the railway wagon, to fix the first truck; step 3, closing the first support plate of each of the middle running plate assemblies to place the first running plate vertically, closing the second support plate of each of the end running plate assemblies at one end of the railway wagon to place the second running plate in a flip-up manner, and folding the foldable support mechanism of the bridge plate device at one end of the railway wagon and opening the connection plate to placing the bridge plate device on the underframe assembly; step 4, driving a second truck into the railway wagon from the underframe assembly at one end of the railway wagon to the underframe assembly at the other end of the railway wagon close to a position below the bridge plate where the first truck is located, and securing the second truck; step 5, driving a third truck into the railway wagon from the underframe assembly at one end of the railway wagon to a position close to the second truck, and securing the third truck; step 6, flipping the second running plate of each of the end running plate assemblies close to one end of the railway wagon down to place horizontally the second running plate, and opening the second support plate to

support and secure the second running plate, supporting the bridge plate device close to one end of the railway wagon with the foldable support mechanism and connecting the bridge plate device with the second running plate via the connection plate; and step 7, driving a fourth truck into the railway wagon from the bridge plate device over the third truck and stopping and securing the fourth truck at the bridge plate device.

[0014] The method for unloading the trucks includes: step 1, releasing the first truck and driving the first truck out of the bridge plate device at the other end of the railway wagon; step 2, closing the second support plate of each of the end running plate assemblies at the other end of the railway wagon, to place the second running plate in a flip-up manner, folding the foldable support mechanism of the bridge plate device at the other end of the railway wagon and opening the connection plate, to place the bridge plate device on the underframe assembly; step 3, releasing the second truck and driving the second truck from the underframe assembly at the other end of the railway wagon; step 4, releasing the third truck and driving the third truck from the underframe assembly at the other end of the railway wagon; step 5, placing horizontally the first running plate of each of the middle running plate assemblies and opening the first support plate to support the first running plate, flipping down the second running plate of each of the end running plate assemblies at the other end of the railway wagon to place the second running plate horizontally and opening the second support plate to support and secure the second running plate, supporting the bridge plate device at the other end of the railway wagon with the foldable support mechanism and connecting the bridge plate device with the second running plate via the connection plate; and step 6, releasing the fourth truck and driving the fourth truck out of the bridge plate device at the other end of the railway wagon.

## BENEFITS OF THE APPLICATION

### BENEFITS

[0015] The present application has the following advantages due to the above technical solutions. 1, according to the present application, the device is relatively mounted at the middle portion between two side wall assemblies of the railway wagon, inner space of the railway wagon is reasonably utilized, thereby increasing the number of trucks loaded into the wagon and improving the transportation efficiency. 2, according to the present application, the middle running plate assembly, the end running plate assembly and the bridge plate device each have a foldable structure, in this case, an upper layer truck may pass the running plates when the running plates are in a horizontal placed state, and an occupation on the inner space of the railway wagon may be reduced and a truck on the underframe assembly passes the running plates when the running plates are in a non-horizon-

tal state. 3, according to the present application, the steel middle running plate assembly, end running plate assembly and bridge plate are each provided with a pneumatic rod which provides an additional power output for a rotation of the running plate, thereby reducing the work strength of the loading workers and improving the loading and unloading efficiency; in the case that the middle running plate assembly and the end running plate assembly are made of aluminum alloy, the weight of the boards are reduced and no pneumatic rod may be provided. 4, with the devices according to the present application, the truck to be transported may not exceed the gauge of the wagon when being loaded and can be normally driven into and out of the railway wagon.

## BRIEF DESCRIPTION OF THE DRAWINGS

### DESCRIPTION OF THE DRAWINGS

**[0016]** Below, the present application is described in detail in conjunction with the drawings. It should be understood that, the drawings are only for better understanding of the present application and should not be understood to limit the present application.

Figure 1 is a schematic diagram of an entire structure according to the present application;

Figure 2 is a schematic structural diagram of a middle running plate assembly according to the present application;

Figure 3 is a schematic structural diagram of an end running plate assembly according to the present application;

Figure 4 is a schematic structural diagram of a bridge plate device according to the present application;

Figure 5 is a schematic diagram of a non-working position state of a bridge plate device according to the present application;

Figure 6 is a schematic diagram of a non-working position state of an end running plate assembly according to the present application;

Figure 7 is a schematic diagram showing a loading of a first truck according to the present application;

Figure 8 is a schematic diagram showing a loading of a second truck according to the present application;

Figure 9 is a schematic diagram showing a loading of a third truck according to the present application; and

Figure 10 is a schematic diagram showing a loading of a fourth truck according to the present application.

## EMBODIMENTS OF INVENTION

### EMBODIMENTS OF THE PRESENT APPLICATION

**[0017]** Hereinafter, the present application is described in detail in conjunction with the drawings and embodiments.

**[0018]** As shown in Figure 1, the present application includes a running plate device mounted relatively at a middle portion between two side wall assemblies of a railway wagon. The running plate device includes a middle running plate device 100. Two ends of the middle running plate device 100 are respectively provided with an end running plate device 200, and an outer ends of the end running plate device 200 is provided with a bridge plate device 300.

**[0019]** The middle running plate device 100 includes multiple middle running assemblies 1 arranged side by side. As shown in Figure 2, each of the middle running plate assemblies 1 includes a rectangular running plate 11 rotatably connected with a side wall assembly via an axle seat 14. Two support plates 12 rotatably connected with the side wall assembly via the axle seat 14 are arranged and spaced below the running plate 11, and the two support plates 12 together support the running plate 11, so as to maintain the running plate 11 being placed horizontally.

**[0020]** The end running plate device 200 includes multiple end running plate assembly 2 arranged side by side. As shown in Figure 3, each of the end running assembly 2 includes a rectangular running plate 21 rotatably connected with the side wall assembly via an axle seat 25. Two support plates 22 rotatably connected with the side wall assembly via the axle seat 25 are arranged and spaced below the running plate 21, and the two support plates 22 together support the running plate 21, so as to maintain the running plate 21 being placed horizontally.

**[0021]** As shown in Figure 4, the bridge plate device 300 includes a bridge plate 31. One end of the bridge plate 31 is connected with the running plate 21 via a connection plate 4, and the other end of the bridge plate 31 is rotatably connected with an underframe assembly. The bottom of the end of the bridge plate 31 close to the connection plate 4 is provided with a foldable support mechanism 32 for placing the bridge plate device 300 in a non-working state on the underframe assembly (as shown in Figure 5), thereby facilitating truck being loaded and unloaded.

**[0022]** In the above embodiment, two end of the running plate 11 are each provided with a pneumatic rod 13 rotatably connected with the side wall assembly. The pneumatic rod 13 can provide additional output power when the running plate 11 is rotated. The running plate may be made of steel or aluminum alloy. No pneumatic rod 13 may be provided when the running plate is made

of aluminum alloy.

**[0023]** In the above embodiment, the middle running assembly 1 located at the end portion of the middle running plate device 100 may be arranged tiltedly, and the middle running plate assembly 1 located at the middle portion of the middle running plate device 100 may be arranged horizontally. In this way, a recess structure is formed in the middle running plate device 100, thereby avoiding an interference between the truck and the middle running plate assembly 1 during a loading and unloading.

**[0024]** In the above embodiment, two ends of the running plate 21 are each provided with a pneumatic rod 23, and a piston rod 231 of the pneumatic rod 23 is rotatably connected with the side wall assembly. A pressure tube 23 of the pneumatic rod 23 is connected with the running plate 21 via a connection member 24. In this case, when the pneumatic rod 23 extends, the pressure tube 23 may drive the running plate 21 to rotate upwards (as shown in Figure 6). The running plate 21 may be made of steel or aluminum alloy. No pneumatic rod 23 may be provided when the running plate 21 is made of aluminum alloy.

**[0025]** In the above embodiment, the bottom of the bridge plate 31 is provided with multiple pneumatic rods 33 rotatably connected with the underframe assembly.

**[0026]** In the above embodiment, the foldable support mechanism 32 includes two supports 321 both having a right-angled triangle shape. The two supports 321 are arranged against to each other and rotatably connected with each other. Ends of the two supports 321 that are opposite to a joint connected to each other are respectively rotatably connected with the bridge plate 31 and the underframe assembly, thereby achieving a folding of the foldable support mechanism 32.

**[0027]** In the above embodiment, a connection plate 5 may be arranged between the end running plate assembly 2 and the middle running plate assembly 1.

**[0028]** In the above embodiment, the number of the middle running plate assemblies 1 is ten, the number of the end running plate assemblies 2 is eight, and four bridge plate devices 300 are provided.

**[0029]** A method for loading trucks is further provided according to the present application. As shown in Figures 7 to 10, the method includes steps 1 to 7.

**[0030]** In step 1, the running plate 11 of each of the middle running plate assemblies 1 is placed horizontally and the support plate 12 is opened to support and secure the running plate 11, the running plate 21 of each of the end running plate assemblies 2 is flipped down and placed horizontally and the support plate 22 is opened to support and secure the running plate 21, and each of the bridge plate devices 300 is supported with the foldable support mechanism 32 and is connected with the running plate 21 via the connection plate 4.

**[0031]** In step 2, a first truck 6 is driven into the railway wagon from the bridge plate device 300 at one end of the railway wagon to the bridge plate device 300 at the other end of the railway wagon and is stopped, and then,

the first truck 6 is secured.

**[0032]** In step 3, the support plate 12 of each of the middle running plate assemblies 1 is closed to place the running plate 11 vertically, and the support plate 22 of each of the end running plate assemblies 2 at one end of the railway wagon to place the running plate 21 in a flip-up manner, and the foldable support mechanism 32 of the bridge plate device 300 at one end of the railway wagon is folded and the connection plate 4 is opened to place the bridge plate device 300 on the underframe assembly.

**[0033]** In step 4, a second truck 7 is driven into the railway wagon from the underframe assembly at one end of the railway wagon to the underframe assembly at the other end of the railway wagon and close to a position below the bridge plate device 300 where the first truck 6 is located, and the second truck 7 is secured.

**[0034]** In step 5, a third truck is driven into the railway wagon from the underframe assembly at one end of the railway wagon to a position close to the second truck 7, and is secured.

**[0035]** In step 6, the running plate 21 of each of the end running plate assemblies 2 close to one end of the railway wagon is flipped down to place the running plate 21 horizontally, and the support plate 22 is opened to support and secure the running plate 21. The bridge plate device 300 close to one end of the railway wagon is supported with the foldable support mechanism 32 and is connected with the running plate 21 via the connection plate 4.

**[0036]** In step 7, a fourth truck 9 is driven into the railway wagon from the bridge plate device 300 over the third truck 8 and is stopped and secured at the bridge plate device 300.

**[0037]** A method for unloading trucks is further provided according to the present application. The method includes steps 1 to 6.

**[0038]** In step 1, the first truck 6 is released and driven out of the bridge plate device 300 at the other end of the railway wagon.

**[0039]** In step 2, the support plate 22 of each of the end running plate assemblies 2 at the other end of the railway wagon is closed to place the running plate 21 in a flip-up manner, the foldable support mechanism 32 of the bridge plate device 300 at the other end of the railway wagon is folded and the connection plate is opened to place the bridge plate device 300 on the underframe assembly.

**[0040]** In step 3, the second truck 7 is released and driven out of the underframe assembly at the other end of the railway wagon.

**[0041]** In step 4, the third truck 8 is released and driven out of the underframe assembly at the other end of the railway wagon.

**[0042]** In step 5, the running plate 11 of each of the middle running plate assemblies 1 is placed horizontally and the support plate 12 is opened to support and secure the running plate 11, the running plate 21 of each of the

end running plate assemblies 2 at the other end of the railway wagon is flipped down and placed horizontally and the support plate 22 is opened to support and secure the running plate 22. The bridge plate device 300 at the other end of the railway wagon is supported with the foldable support mechanism 32 and is connected with the running plate 21 via the connection plate 4.

**[0043]** In step 6, the fourth truck is released and driven out of the bridge plate device 300 at the other end of the railway wagon.

**[0044]** The above embodiments are only for further illustrating the objectives, technical solutions and benefits of the present application in detail, and are not intended to limit the present application. Accordingly, the application is not to be seen as limited by the foregoing description, but is only limited by the scope of the appended claims.

## Claims

### 1. A railway wagon for transporting trucks, comprising:

a running plate device mounted relatively at a middle portion between two side wall assemblies of the railway wagon,

wherein the running plate device comprises a middle running plate device (100), two ends of the middle running plate device (100) are each provided with an end running plate device (200), and an outer end of the end running plate device is provided with a bridge plate device (300); the middle running plate device (100) comprises a plurality of middle running plate assemblies (1) arranged side by side, each of the middle running plate assemblies (1) comprises a first running plate (11) rotatably connected with an side wall assembly, and at least one first support plate (12) rotatably connected with the side wall assembly is arranged below the first running plate (11);

the end running plate device (200) comprises a plurality of end running plate assemblies (2) arranged side by side, each of the end running plate assemblies (200) comprises a second running plate (21) rotatably connected with the side wall assembly, and at least one second support plate (22) rotatably connected with the side wall assembly is arranged below the second running plate (21); and

the bridge plate device (300) comprises a bridge plate (31), one end of the bridge plate (31) is connected with the second running plate (21) via a connection plate (4), the other end of the bridge plate (31) is rotatably connected with an underframe assembly of the railway wagon, and a bottom portion of the end of the bridge plate (31) close to the connection plate (4) is provided

with a foldable support mechanism (32).

2. The railway wagon for transporting trucks according to claim 1, wherein two ends of the first running plate (11) are each provided with a first pneumatic rod (13) rotatably connected to the side wall assembly.

3. The railway wagon for transporting trucks according to claim 1 or 2, wherein two ends of the second running plate (21) are each provided with a second pneumatic rod (23), a piston rod (231) of the second pneumatic rod (23) is rotatably connected to the side wall assembly, and a pressure tube (232) of the second pneumatic rod (23) is securely connected with the second running plate (21) via a connection member (24).

4. The railway wagon for transporting trucks according to claim 1 or 2, wherein a bottom portion of the bridge plate (31) is provided with a plurality of third pneumatic rods (33) rotatably connected with the underframe assembly.

5. The railway wagon for transporting trucks according to claim 1 or 2, wherein the middle running plate assemblies (100) located at the two ends of the middle running plate device (1) are arranged tiltedly, and the middle running plate assemblies located at the middle of the middle running plate device (1) are arranged horizontally.

6. The railway wagon for transporting trucks according to claim 1 or 2, wherein the foldable support mechanism (32) comprises two supports (321) both having a right-angled triangle shape, the two supports (321) are arranged against each other and are rotatably connected with each other, and the two supports (321) are respectively rotatably connected with the bridge plate (31) and the underframe assembly.

7. The railway wagon for transporting trucks according to claim 1 or 2, wherein a second connection plate (5) is arranged between the end running plate assembly (2) and the middle running plate assembly (1).

8. A method for loading and unloading trucks on the railway wagon according to any one of claims 1 to 7, wherein the method for loading the trucks comprising:

step 1, placing horizontally the first running plate (11) of each of the middle running plate assemblies (1) and opening the first support plate (12) to support and secure the first running plate (11), flipping down the second running plate of each of the end running plate assemblies (2) to place the second running plate (21) horizontally and

opening the second support plate (22) to support and secure the second running plate (21), supporting the bridge plate device (300) with the foldable support mechanism (32) and connecting the bridge plate device (300) with the second running plate (21) via the connection plate (4);

step 2, driving a first truck (6) from the bridge plate device at one end of the railway wagon to the bridge plate device (300) at the other end of the railway wagon and stopping the first truck at the bridge plate device (300) at the other end of the railway wagon, and securing the first truck;

step 3, closing the first support plate (12) of each of the middle running plate assemblies (1) to place the first running plate (11) vertically, closing the second support plate (2) of each of the end running plate assemblies (22) at one end of the railway wagon to place the second running plate (21) in a flip-up manner, and folding the foldable support mechanism (32) of the bridge plate device (300) at one end of the railway wagon and opening the connection plate (4) to place the bridge plate device (300) on the underframe assembly;

step 4, driving a second truck (7) into the railway wagon from the underframe assembly at one end of the railway wagon to the underframe assembly at the other end of the railway wagon close to a position below the bridge plate device (300) where the first truck (6) is located, and securing the second truck;

step 5, driving a third truck (8) into the railway wagon from the underframe assembly at one end of the railway wagon to a position close to the second truck (7), and securing the third truck (8);

step 6, flipping the second running plate (21) of each of the end running plate assemblies (2) close to one end of the railway wagon down to place horizontally the second running plate (21), and opening the second support plate (22) to support and secure the second running plate (21), supporting the bridge plate device (300) close to one end of the railway wagon with the foldable support mechanism (32) and connecting the bridge plate device (300) with the second running plate (21) via the connection plate (4); and

step 7, driving a fourth truck (9) into the railway wagon from the bridge plate device (300) over the third truck (8) and stopping and securing the fourth truck (9) at the bridge plate device (300); and

the method for unloading the trucks comprising:

step 1, releasing the first truck (6) and driving the first truck (6) out of the bridge plate device

(300) at the other end of the railway wagon;

step 2, closing the second support plate (22) of each of the end running plate assemblies (2) at the other end of the railway wagon to place the second running plate (21) in a flip-up manner, folding the foldable support mechanism (32) of the bridge plate device (300) at the other end of the railway wagon and opening the connection plate (4) to place the bridge plate device (300) on the underframe assembly;

step 3, releasing the second truck (7) and driving the second truck from the underframe assembly at the other end of the railway wagon;

step 4, releasing the third truck (8) and driving the third truck from the underframe assembly at the other end of the railway wagon;

step 5, placing horizontally the first running plate (11) of each of the middle running plate assemblies (1) and opening the first support plate (12) to support the first running plate (11), flipping down the second running plate (21) of each of the end running plate assemblies (2) at the other end of the railway wagon to place the second running plate (21) horizontally and opening the second support plate (22) to support and secure the second running plate (21), supporting the bridge plate device (300) at the other end of the railway wagon with the foldable support mechanism (32) and connecting the bridge plate device (300) with the second running plate (21) via the connection plate (4); and

step 6, releasing the fourth truck (9) and driving the fourth truck (9) out of the bridge plate device (300) at the other end of the railway wagon.

## Patentansprüche

1. Eisenbahnwagen zum Transportieren von Lastkraftwagen, aufweisend:

eine Laufplattenvorrichtung, die relativ an einem Mittelteil zwischen zwei Seitenwandanordnungen des Eisenbahnwagens angebracht ist, wobei die Laufplattenvorrichtung eine mittlere Laufplattenvorrichtung (100) aufweist, zwei Enden der mittleren Laufplattenvorrichtung (100) jeweils mit einer Endlaufplattenvorrichtung (200) versehen sind und ein äußeres Ende der Endlaufplattenvorrichtung mit einer Brückenplattenvorrichtung (300) versehen ist; die mittlere Laufplattenvorrichtung (100) eine Vielzahl von nebeneinander angeordneten mittleren Laufplattenanordnungen (1) aufweist, wobei jede der mittleren Laufplattenanordnungen (1) eine erste Laufplatte (11) aufweist, die drehbar mit einer Seitenwandanordnung verbunden ist, und mindestens eine erste Stützplatte (12),

- die drehbar mit der Seitenwandaanordnung verbunden ist, unterhalb der ersten Laufplatte (11) angeordnet ist;  
 die Endlaufplattenvorrichtung (200) eine Vielzahl von nebeneinander angeordneten Endlaufplattenanordnungen (2) aufweist, jede der Endlaufplattenanordnungen (200) eine zweite Laufplatte (21) aufweist, die drehbar mit der Seitenwandaanordnung verbunden ist, und mindestens eine zweite Stützplatte (22), die drehbar mit der Seitenwandaanordnung verbunden ist, unterhalb der zweiten Laufplatte (21) angeordnet ist; und die Brückenplattenvorrichtung (300) eine Brückenplatte (31) aufweist, ein Ende der Brückenplatte (31) über eine Verbindungsplatte (4) mit der zweiten Laufplatte (21) verbunden ist, das andere Ende der Brückenplatte (31) drehbar mit einer Untergestellanordnung des Eisenbahnwagens verbunden ist und ein unterer Abschnitt des Endes der Brückenplatte (31) nahe der Verbindungsplatte (4) mit einem klappbaren Stützmechanismus (32) versehen ist.
2. Eisenbahnwagen zum Transportieren von Lastkraftwagen nach Anspruch 1, wobei zwei Enden der ersten Laufplatte (11) jeweils mit einer ersten Pneumatikstange (13) versehen sind, die drehbar mit der Seitenwandaanordnung verbunden ist.
3. Eisenbahnwagen zum Transportieren von Lastkraftwagen nach Anspruch 1 oder 2, wobei zwei Enden der zweiten Laufplatte (21) jeweils mit einer zweiten Pneumatikstange (23) versehen sind, eine Kolbenstange (231) der zweiten Pneumatikstange (23) drehbar mit der Seitenwandaanordnung verbunden ist und ein Druckrohr (232) der zweiten Pneumatikstange (23) über ein Verbindungselement (24) fest mit der zweiten Laufplatte (21) verbunden ist.
4. Eisenbahnwagen zum Transportieren von Lastkraftwagen nach Anspruch 1 oder 2, wobei ein unterer Abschnitt der Brückenplatte (31) mit einer Vielzahl von dritten Pneumatikstangen (33) versehen ist, die drehbar mit der Untergestellanordnung verbunden sind.
5. Eisenbahnwagen zum Transportieren von Lastkraftwagen nach Anspruch 1 oder 2, wobei die an den beiden Enden der mittleren Laufplattenvorrichtung (1) befindlichen mittleren Laufplattenanordnungen (100) geneigt angeordnet sind und die in der Mitte der mittleren Laufplattenvorrichtung (1) befindlichen mittleren Laufplattenanordnungen horizontal angeordnet sind.
6. Eisenbahnwagen zum Transportieren von Lastkraftwagen nach Anspruch 1 oder 2, wobei der klappbare Stützmechanismus (32) zwei Stützen (321) aufweist, die beide eine rechtwinklige Dreiecksform aufweisen, die beiden Stützen (321) gegeneinander angeordnet und drehbar miteinander verbunden sind, und die beiden Stützen (321) jeweils drehbar mit der Brückenplatte (31) und der Untergestellanordnung verbunden sind.
7. Eisenbahnwagen zum Transportieren von Lastkraftwagen nach Anspruch 1 oder 2, wobei eine zweite Verbindungsplatte (5) zwischen der Endlaufplattenanordnung (2) und der mittleren Laufplattenanordnung (1) angeordnet ist.
8. Verfahren zum Auf- und Abladen von Lastkraftwagen auf den Eisenbahnwagen nach einem der Ansprüche 1 bis 7, wobei das Verfahren zum Aufladen der Lastkraftwagen Folgendes umfasst:
- Schritt 1, horizontales Platzieren der ersten Laufplatte (11) jeder der mittleren Laufplattenanordnungen (1) und Öffnen der ersten Stützplatte (12) zum Stützen und Sichern der ersten Laufplatte (11), Herunterklappen der zweiten Laufplatte jeder der Endlaufplattenanordnungen (2) zum horizontalen Platzieren der zweiten Laufplatte (21), und Öffnen der zweiten Stützplatte (21) zum Stützen und Sichern der zweiten Laufplatte (21), Stützen der Brückenplattenvorrichtung (300) mit dem klappbaren Stützmechanismus (32) und Verbinden der Brückenplattenvorrichtung (300) mit der zweiten Laufplatte (21) über die Verbindungsplatte (4);
- Schritt 2, Fahren eines ersten Lastkraftwagens (6) von der Brückenplattenvorrichtung an einem Ende des Eisenbahnwagens zu der Brückenplattenvorrichtung (300) am anderen Ende des Eisenbahnwagens und Anhalten des ersten Lastkraftwagens an der Brückenplattenvorrichtung (300) am anderen Ende des Eisenbahnwagens, und Sichern des ersten Lastkraftwagens;
- Schritt 3, Schließen der ersten Stützplatte (12) jeder der mittleren Laufplattenanordnungen (1), um die erste Laufplatte (11) vertikal zu platzieren, Schließen der zweiten Stützplatte (2) von jeder der Endlaufplattenanordnungen (22) an einem Ende des Eisenbahnwagens, um die zweite Laufplatte (21) hochklappbar zu platzieren, und Klappen des klappbaren Stützmechanismus (32) der Brückenplattenvorrichtung (300) an einem Ende des Eisenbahnwagens und Öffnen der Verbindungsplatte (4), um die Brückenplattenvorrichtung (300) auf der Untergestellanordnung zu platzieren;
- Schritt 4, Einfahren eines zweiten Lastkraftwagens (7) in den Eisenbahnwagen von der Untergestellanordnung an einem Ende des Eisenbahnwagens zu der Untergestellanordnung am

anderen Ende des Eisenbahnwagens in der Nähe einer Position unterhalb der Brückenplatten-  
vorrichtung (300), wo sich der erste Lastkraft-  
wagen (6) befindet, und Sichern des zweiten  
Lastkraftwagens;

Schritt 5, Einfahren eines dritten Lastkraftwa-  
gens (8) in den Eisenbahnwagen von der Un-  
tergestellanordnung an einem Ende des Eisen-  
bahnwagens zu einer Position nahe dem zwei-  
ten Lastkraftwagen (7), und Sichern des dritten  
Lastkraftwagens (8);

Schritt 6, Herunterklappen der zweiten Laufplat-  
te (21) jeder der Endlaufplattenanordnungen (2)  
in der Nähe eines Endes des Eisenbahnwa-  
gens, um die zweite Laufplatte (21) horizontal  
zu platzieren, und Öffnen der zweiten Stützplat-  
te (22), um die zweite Laufplatte (21) zu stützen  
und zu sichern, Stützen der Brückenplatten-  
vorrichtung (300) in der Nähe eines Endes des Ei-  
senbahnwagens mit dem klappbaren Stützme-  
chanismus (32) und Verbinden der Brückenplat-  
tenvorrichtung (300) mit der zweiten Laufplatte  
(21) über die Verbindungsplatte (4); und

Schritt 7, Einfahren eines vierten Lastkraftwa-  
gens (9) in den Eisenbahnwagen von der Brü-  
ckenplattenvorrichtung (300) über den dritten  
Lastkraftwagen (8) und Anhalten und Sichern  
des vierten Lastkraftwagens (9) an der Brü-  
ckenplattenvorrichtung (300); und

wobei das Verfahren zum Abladen der Lastkraftwa-  
gen Folgendes umfasst:

Schritt 1, Lösen des ersten Lastkraftwagens (6)  
und Herausfahren des ersten Lastkraftwagens  
(6) aus der Brückenplattenvorrichtung (300) am  
anderen Ende des Eisenbahnwagens;

Schritt 2, Schließen der zweiten Stützplatte (22)  
jeder der Endlaufplattenanordnungen (2) am  
anderen Ende des Eisenbahnwagens, um die  
zweite Laufplatte (21) hochklappbar zu platzie-  
ren, Klappen des klappbaren Stützmechani-  
smus (32) der Brückenplattenvorrichtung (300)  
am anderen Ende des Eisenbahnwagens und  
Öffnen der Verbindungsplatte (4), um die Brü-  
ckenplattenvorrichtung (300) auf der Unterge-  
stellanordnung zu platzieren;

Schritt 3, Lösen des zweiten Lastkraftwagens  
(7) und Wegfahren des zweiten Lastkraftwa-  
gens von der Untergestellanordnung am ande-  
ren Ende des Eisenbahnwagens;

Schritt 4, Lösen des dritten Lastkraftwagens (8)  
und Wegfahren des dritten Lastkraftwagens von  
der Untergestellanordnung am anderen Ende  
des Eisenbahnwagens;

Schritt 5, horizontales Platzieren der ersten  
Laufplatte (11) jeder der mittleren Laufplatten-  
anordnungen (1) und Öffnen der ersten Stützplat-

te (12) zum Stützen der ersten Laufplatte (11),  
Herunterklappen der zweiten Laufplatte (21) je-  
der der Endlaufplattenanordnungen (2) am an-  
deren Ende des Eisenbahnwagens, um die  
zweite Laufplatte (21) horizontal zu platzieren,  
und Öffnen der zweiten Stützplatte (22) zum  
Stützen und Sichern der zweiten Laufplatte (21),  
Stützen der Brückenplattenvorrichtung (300)  
am anderen Ende des Eisenbahnwagens mit  
dem klappbaren Stützmechanismus (32) und  
Verbinden der Brückenplattenvorrichtung (300)  
mit der zweiten Laufplatte (21) über die Verbind-  
ungsplatte (4); und

Schritt 6, Lösen des vierten Lastkraftwagens (9)  
und Herausfahren des vierten Lastkraftwagens  
(9) aus der Brückenplattenvorrichtung (300) am  
anderen Ende des Eisenbahnwagens.

## Revendications

1. Wagon de chemin de fer pour transporter des ca-  
mions, comprenant :

un dispositif de plaque de roulement monté re-  
lativement à une partie centrale entre deux en-  
sembles de parois latérales du wagon de che-  
min de fer,

dans lequel le dispositif de plaque de roulement  
comprend un dispositif de plaque de roulement  
central (100), deux extrémités du dispositif de  
plaque de roulement central (100) sont chacunes  
pourvues d'un dispositif de plaque de roulement  
d'extrémité (200), et une extrémité extérieure du  
dispositif de plaque de roulement d'extrémité est  
pourvue d'un dispositif de plaque de pont (300) ;  
le dispositif de plaque de roulement central (100)  
comprend une pluralité d'ensembles de plaques  
de roulement centrales (1) disposés côte à côte,  
chacun des ensembles de plaques de roulement  
centrales (1) comprend une première plaque  
de roulement (11) reliée de manière rotative  
à un ensemble de paroi latérale, et au moins  
une première plaque de support (12) reliée de  
manière rotative à l'ensemble de paroi latérale  
est disposée sous la première plaque de roulement  
(11) ;

le dispositif de plaque de roulement d'extrémité  
(200) comprend une pluralité d'ensembles de  
plaque de roulement d'extrémité (2) disposés  
côte à côte, chacun des ensembles de plaque  
de roulement d'extrémité (200) comprend une  
seconde plaque de roulement (21) reliée de ma-  
nière rotative à l'ensemble de paroi latérale, et  
au moins une seconde plaque de support (22)  
reliée de manière rotative à l'ensemble de paroi  
latérale est disposée sous la seconde plaque de  
roulement (21) ; et

- le dispositif de plaque de pont (300) comprend une plaque de pont (31), une extrémité de la plaque de pont (31) est reliée à la seconde plaque de roulement (21) via une plaque de connexion (4), l'autre extrémité de la plaque de pont (31) est reliée de manière rotative à un ensemble de châssis du wagon de chemin de fer, et une partie inférieure de l'extrémité de la plaque de pont (31) proche de la plaque de connexion (4) est pourvue d'un mécanisme de support pliable (32).
2. Wagon de chemin de fer pour transporter des camions selon la revendication 1, dans lequel deux extrémités de la première plaque de roulement (11) sont chacune pourvues d'une première tige pneumatique (13) reliée de manière rotative à l'ensemble de paroi latérale.
  3. Wagon de chemin de fer pour transporter des camions selon la revendication 1 ou 2, dans lequel deux extrémités de la seconde plaque de roulement (21) sont chacune pourvues d'une seconde tige pneumatique (23), une tige de piston (231) de la seconde tige pneumatique (23) est reliée de manière rotative à l'ensemble de paroi latérale, et un tube de force (232) de la seconde tige pneumatique (23) est relié de manière fixe à la seconde plaque de roulement (21) par un élément de connexion (24).
  4. Wagon de chemin de fer pour transporter des camions selon la revendication 1 ou 2, dans lequel une partie inférieure de la plaque de pont (31) est pourvue d'une pluralité de troisièmes tiges pneumatiques (33) reliées de manière rotative à l'ensemble de châssis.
  5. Wagon de chemin de fer pour transporter des camions selon la revendication 1 ou 2, dans lequel les ensembles de plaques de roulement centrales (100) situés aux deux extrémités du dispositif de plaque de roulement central (1) sont disposés de manière inclinée, et les ensembles de plaques de roulement centrales situés au milieu du dispositif de plaque de roulement central (1) sont disposés horizontalement.
  6. Wagon de chemin de fer pour transporter des camions selon la revendication 1 ou 2, dans lequel le mécanisme de support pliable (32) comprend deux supports (321) ayant tous les deux une forme de triangle rectangulaire, les deux supports (321) sont disposés l'un contre l'autre et sont reliés de manière rotative l'un avec l'autre, et les deux supports (321) sont respectivement reliés de manière rotative à la plaque de pont (31) et à l'ensemble de châssis.
  7. Wagon de chemin de fer pour transporter des ca-
- mions selon la revendication 1 ou 2, dans lequel une seconde plaque de connexion (5) est disposée entre l'ensemble de plaque de roulement d'extrémité (2) et l'ensemble de plaque de roulement centrale (1).
8. Procédé pour charger et décharger des camions du wagon de chemin de fer selon l'une quelconque des revendications 1 à 7, dans lequel le procédé pour charger les camions comprenant :
    - étape 1 : placer horizontalement la première plaque de roulement (11) de chacun des ensembles de plaques de roulement centrales (1) et ouvrir la première plaque de support (12) pour soutenir et fixer la première plaque de roulement (11), rabattre vers le bas la seconde plaque de roulement de chacun des ensembles de plaque de roulement d'extrémité (2) pour placer horizontalement la seconde plaque de roulement (21) et ouvrir la seconde plaque de support (22) pour soutenir et fixer la seconde plaque de roulement (21), soutenir le dispositif de plaque de pont (300) avec le mécanisme de support pliable (32) et relier le dispositif de plaque de pont (300) à la seconde plaque de roulement (21) par l'intermédiaire de la plaque de connexion (4) ;
    - étape 2 : conduire un premier camion (6) du dispositif de plaque de pont à une extrémité du wagon de chemin de fer sur le dispositif de plaque de pont (300) à l'autre extrémité du wagon de chemin de fer et arrêter le premier camion au dispositif de plaque de pont (300) à l'autre extrémité du wagon de chemin de fer, et fixer le premier camion ;
    - étape 3 : fermer la première plaque de support (12) de chacun des ensembles de plaques de roulement centrales (1) pour placer verticalement la première plaque de roulement (11), fermer la seconde plaque de support (2) de chacun des ensembles de plaque de roulement d'extrémité (22) à une extrémité du wagon de chemin de fer pour placer la seconde plaque de roulement (21) de manière à ce qu'elle soit relevée, et plier le mécanisme de support pliable (32) du dispositif de plaque de pont (300) à une extrémité du wagon de chemin de fer et ouvrir la plaque de connexion (4) pour placer le dispositif de plaque de pont (300) sur l'ensemble de châssis ;
    - étape 4 : conduire un second camion (7) dans le wagon de chemin de fer depuis l'ensemble de châssis à une extrémité du wagon de chemin de fer jusqu'à l'ensemble de châssis à l'autre extrémité du wagon de chemin de fer proche d'une position sous le dispositif de plaque de pont (300) où se trouve le premier camion (6), et fixer le second camion ;
    - étape 5 : conduire un troisième camion (8) dans le wagon de chemin de fer depuis l'ensemble

de châssis à une extrémité du wagon de chemin de fer jusqu'à une position proche du second camion (7), et fixer le troisième camion (8) ;  
 étape 6 : basculer vers le bas la seconde plaque de roulement (21) de chacun des ensembles de plaque de roulement d'extrémité (2) près d'une extrémité du wagon de chemin de fer pour placer horizontalement la seconde plaque de roulement (21), et ouvrir la seconde plaque de support (22) pour soutenir et fixer la seconde plaque de roulement (21), soutenir le dispositif de plaque de pont (300) proche d'une extrémité du wagon de chemin de fer avec le mécanisme de support pliable (32) et relier le dispositif de plaque de pont (300) à la seconde plaque de roulement (21) via la plaque de connexion (4) ; et  
 étape 7 : conduire un quatrième camion (9) dans le wagon de chemin de fer depuis le dispositif de plaque de pont (300) au-dessus du troisième camion (8) et arrêter et fixer le quatrième camion (9) au dispositif de plaque de pont (300) ; et

le procédé pour décharger les camions comprenant :

étape 1 : débloquer le premier camion (6) et conduire le premier camion (6) hors du dispositif de plaque de pont (300) à l'autre extrémité du wagon de chemin de fer ;  
 étape 2 : fermer la seconde plaque de support (22) de chacun des ensembles de plaque de roulement d'extrémité (2) à l'autre extrémité du wagon de chemin de fer pour placer la seconde plaque de roulement (21) de manière à ce qu'elle soit relevée, plier le mécanisme de support pliable (32) du dispositif de plaque de pont (300) à l'autre extrémité du wagon de chemin de fer et ouvrir la plaque de connexion (4) pour placer le dispositif de plaque de pont (300) sur l'ensemble de châssis ;  
 étape 3 : débloquer le second camion (7) et conduire le second camion depuis l'ensemble de châssis à l'autre extrémité du wagon de chemin de fer ;  
 étape 4 : débloquer le troisième camion (8) et conduire le troisième camion depuis l'ensemble de châssis à l'autre extrémité du wagon de chemin de fer ;  
 étape 5 : placer horizontalement la première plaque de roulement (11) de chacun des ensembles de plaques de roulement centrales (1) et ouvrir la première plaque de support (12) pour soutenir la première plaque de roulement (11), rabattre vers le bas la seconde plaque de roulement (21) de chacun des ensembles de plaque de roulement d'extrémité (2) à l'autre extrémité du wagon de chemin de fer pour placer horizontalement la seconde plaque de roulement (21)

et ouvrir la seconde plaque de support (22) pour soutenir et fixer la seconde plaque de roulement (21), soutenir le dispositif de plaque de pont (300) à l'autre extrémité du wagon de chemin de fer avec le mécanisme de support pliable (32) et relier le dispositif de plaque de pont (300) à la seconde plaque de roulement (21) via la plaque de connexion (4) ; et  
 étape 6 : débloquer le quatrième camion (9) et conduire le quatrième camion (9) hors du dispositif de plaque de pont (300) à l'autre extrémité du wagon de chemin de fer.

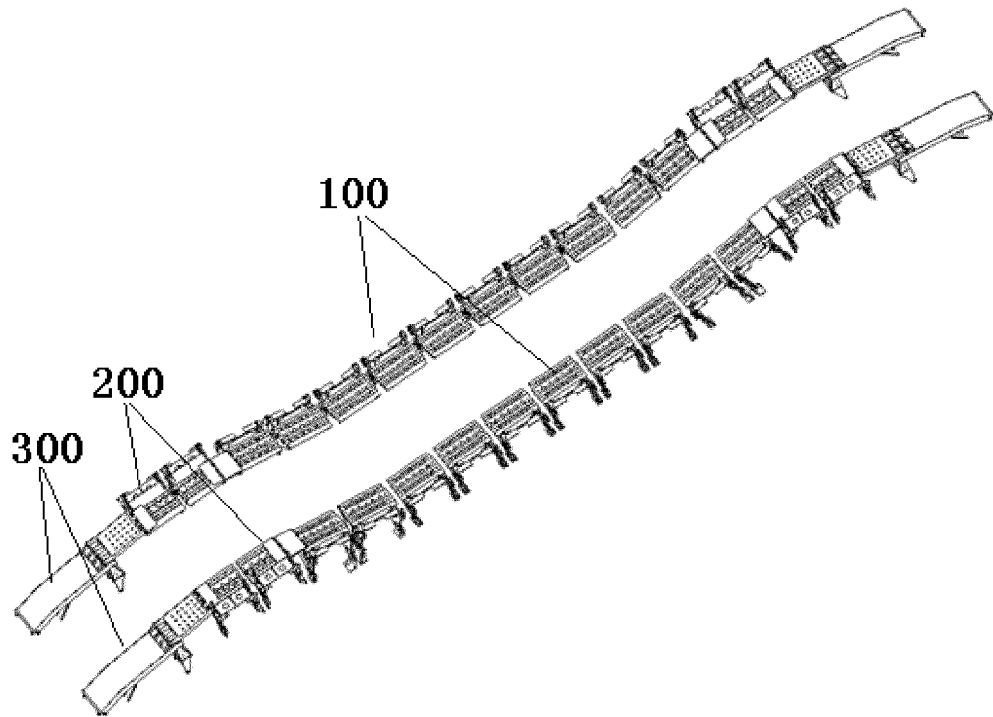

Figure 1

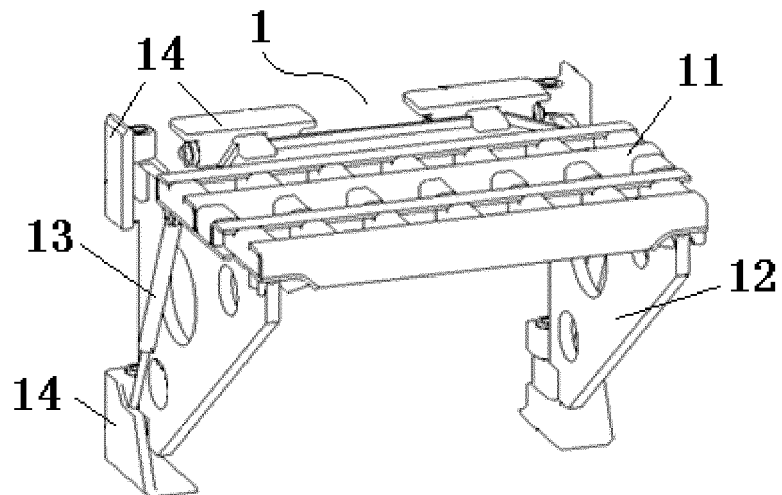

Figure 2

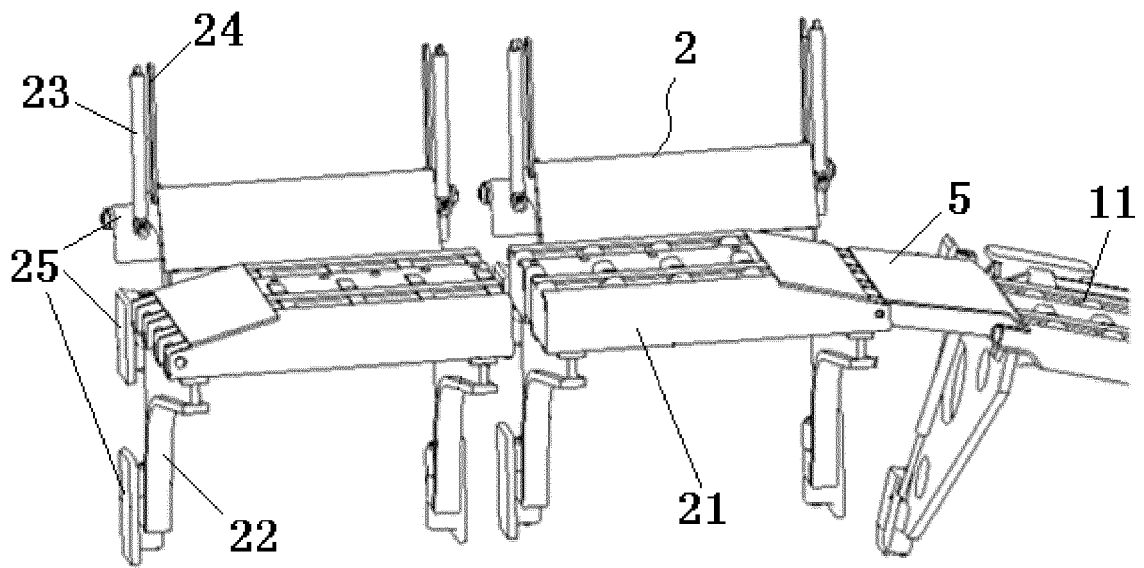

Figure 3

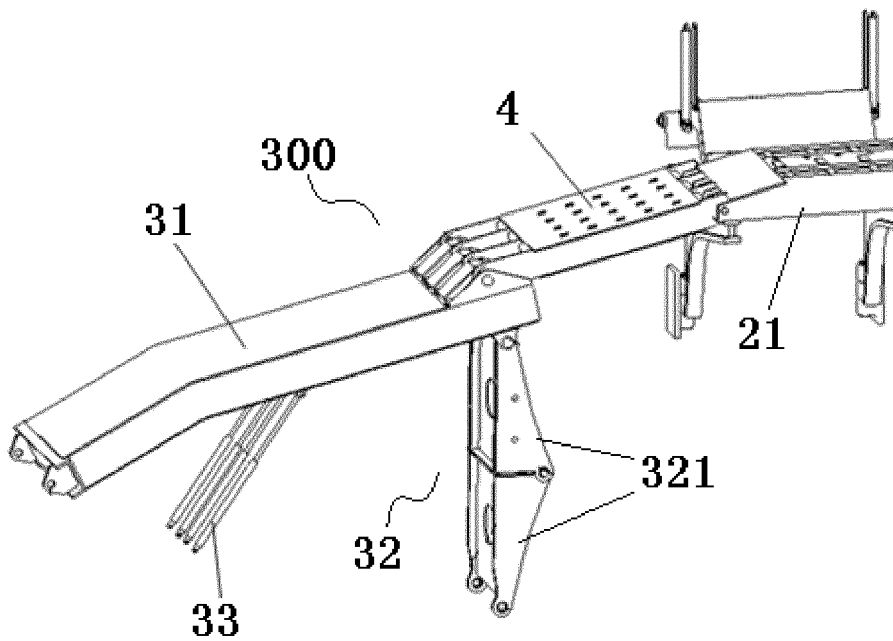

Figure 4

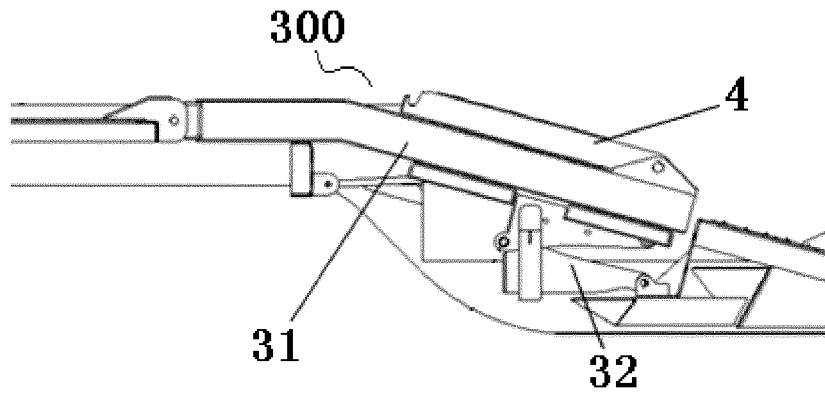

Figure 5

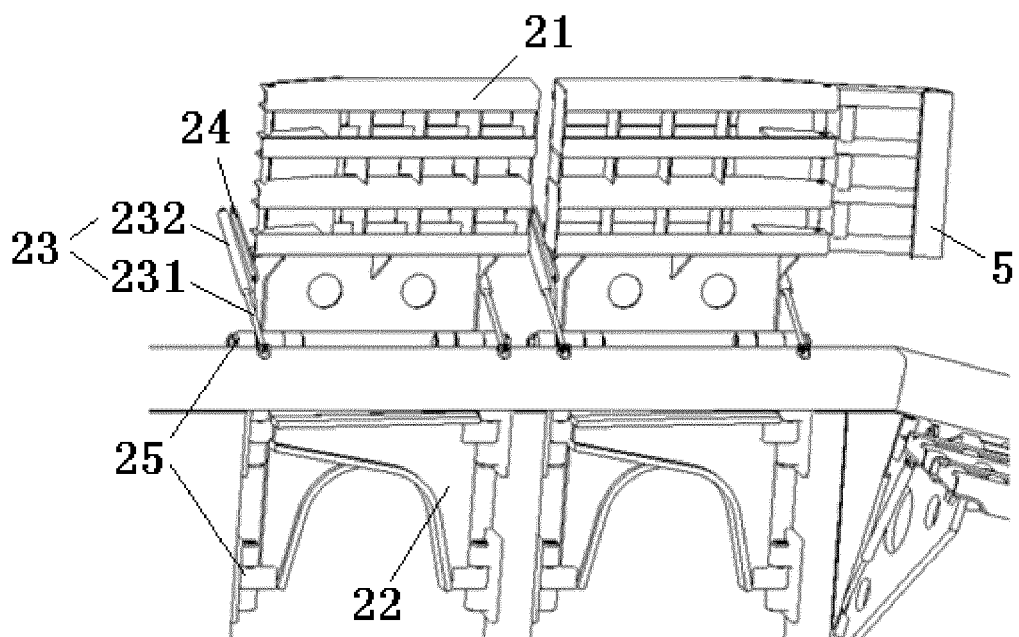

Figure 6

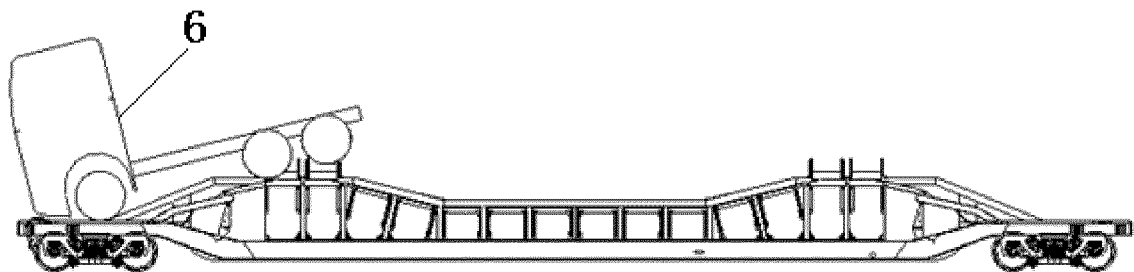

Figure 7

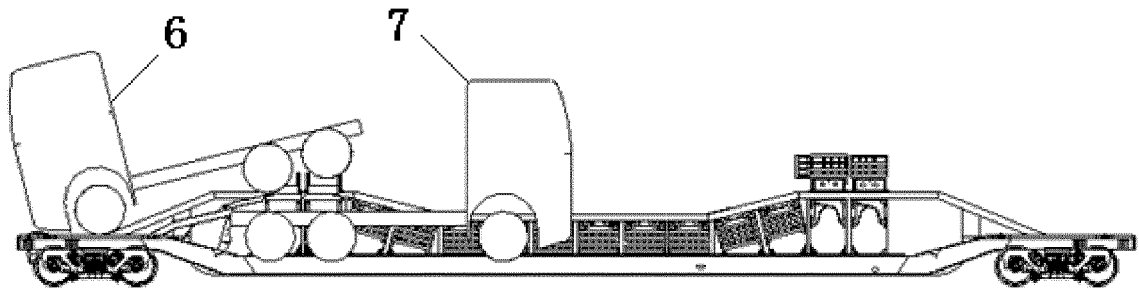

Figure 8

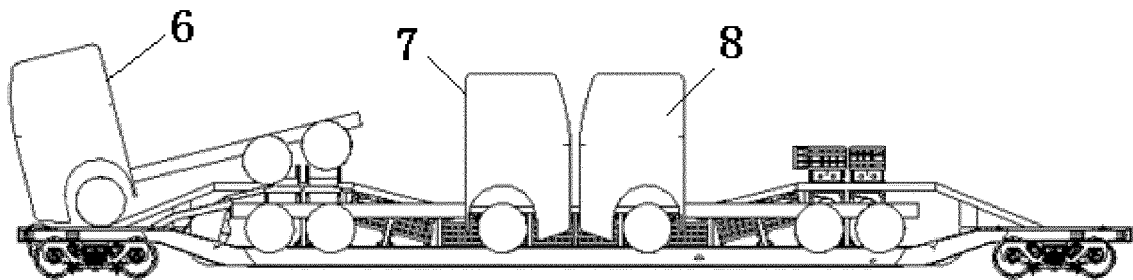

Figure 9

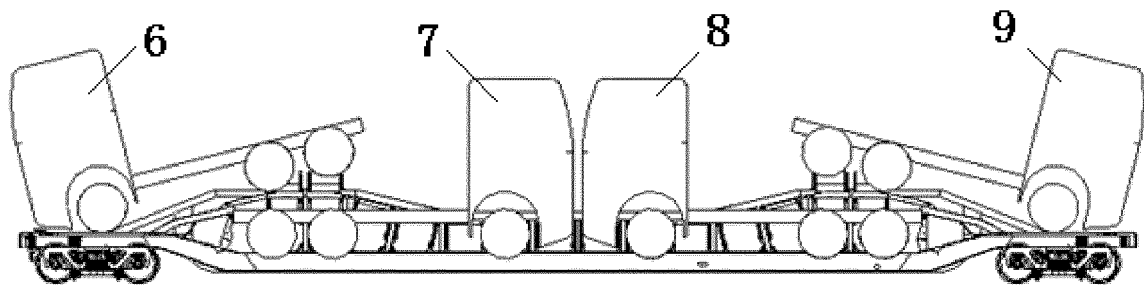

Figure 10

**REFERENCES CITED IN THE DESCRIPTION**

*This list of references cited by the applicant is for the reader's convenience only. It does not form part of the European patent document. Even though great care has been taken in compiling the references, errors or omissions cannot be excluded and the EPO disclaims all liability in this regard.*

**Patent documents cited in the description**

- CN 104386075 A [0003]