

(19)
(12)

(KR)
(A)

(51) 。 Int. Cl. ⁷
B60K 37/00

(11)
(43)

2002 - 0005428
2002 01 17

(21) 10 - 2001 - 0037360
(22) 2001 06 28

(30) 2000 - 208833 2000 07 10 (JP)

(71) 가 가

가 1 1

(72) 가 1 - 1,가 가

(74)

:

(54)

g) (裏面側) (scale plate) (steppin

1 1 .
 2 1 .
 3 2 .
 4 2 (bobbin) .
 5 4 .

*

10 : 20 :
 30 : 30a :
 30b : 30c : (magnet rotor)
 32 : (yoke) 33, 35 :
 34, 36 : 37 :
 38a : 38b, 38c :
 38d : 40 : (pointer)
 41 : 50 :
 60 : Ca, Cb :
 G : (列) M : (stepping motor)

()

2000 7 10

2000 - 208833

(stepping)

(pointer)

JP - A - 9 - 21655

(s

cale plate),

(裏面側)

(導光板),

(LED)

(rotor) (yoke)
(端部) LED가
가 , LED 가

가

(列)

(1)

10) 1 1 2 (20), (20) (10), ((30) , 2 (30a), (40) (30) (pointer base)(41) (30b) (20) (21) (10) (11) (30a) (30a) (31) (31) (31a) (20) (30a)

2 (G) (31) (30a) (31) (M) (30c) (M) (30d) (30d)
 (31) (底部) (32), (32) 1 (Ca, Cb) (Ca, Cb)
 U (32a, 32b 32c) (32) (32) (32) (32) (32)
 形) (Ca, Cb) (32b, 32c) (32)

(Ca) (33), (33) (34) (34)
 33) (矩形) (33a) " a" (2) (33c) , 1 (flange) (33a, 33b)
 (20) (22) (33b) " b" (2) (23)
 (33d) , 1 (34a)가 (33c) (34b) (33d)
 (33c, 33d) , (33c, 33d) (34a, 34b) (20)
 (34a, 34b) (20)

(Cb) (35), (35) (36) (36)
 (35) (矩形) (35a) " c" (2) (35c) , 1 (35a, 35b)
 () (35b) " d" (35d) ,
 (20) () (36a)가 (3)
 5c) (36b) (35d) (35c, 35d) ,
 (35c, 35d) (36a, 36b) (20)
 (36a, 36b) (20)

(Ca, Cb) , (37) (30b) X - X
 (Ca, Cb) (37) (Ca)
 (33b) (30c) (外周部) (Cb) (35b) (30
 c) (30c) (32a) (38a) (37)
 (Ca, Cb), (32) (32a) (磁極) (30c),
 Cb) (30c)가 (37) (31) (20) (Ca,
 (20)

2 (G) (38a), 2 (38b, 38c), (38d)
 (37) (30b) (38b, 38c) (39) (38b)
 (39) (31) (20) (38d)
 (38a) , (38c) , (30b) (38d)
 (30c) (G) 가 (30b)
 (G) (38a - 38d) , (G)

1 (照明) (40) (41) (30a) (30b) LED
 (50) (30b) (20) (10) (20)
 (41) (50) (10) (11) (50)
 LED

a" " b" " c" " d" (Ca) (33c, 33d) (30b) 가 "
 (Cb) (35c, 35d) (30b) 가
 (33c, 33d, 35c, 35d) (20) (30b)
 (50) (30b)
 (20) (50) (40)
 (41)

(2)

2 3 2 (10) (60) 가
 (61) 1 (20) (10) (60) (30b)
 (41) (41) (10) (31) (50)
 (40) (10) (10)

(Ca, Cb) (33c, 33d, 35c, 35d) (20) (30b)
 (50) (30b) 1
 2 (40)
 (10)

c, 33d)((33c, 33d) (33) 가 (33) 4 (50) 5 (33)
 (33c, 33d) (30) (20) (30c)
 (30b) (G)
 (Ca) (33d) (33c) " a"
 (Cb) (35d) (35c) " c"
 (33c, 33d, 35c, 35d) (20) (30b)
 (50)

(32)가 (Ca) (Cb)

가 . 가

(57)

1.

2.

1

3.

1

4.

2

5.

1 ,
 6.
 1 ,
 7.
 1 ,

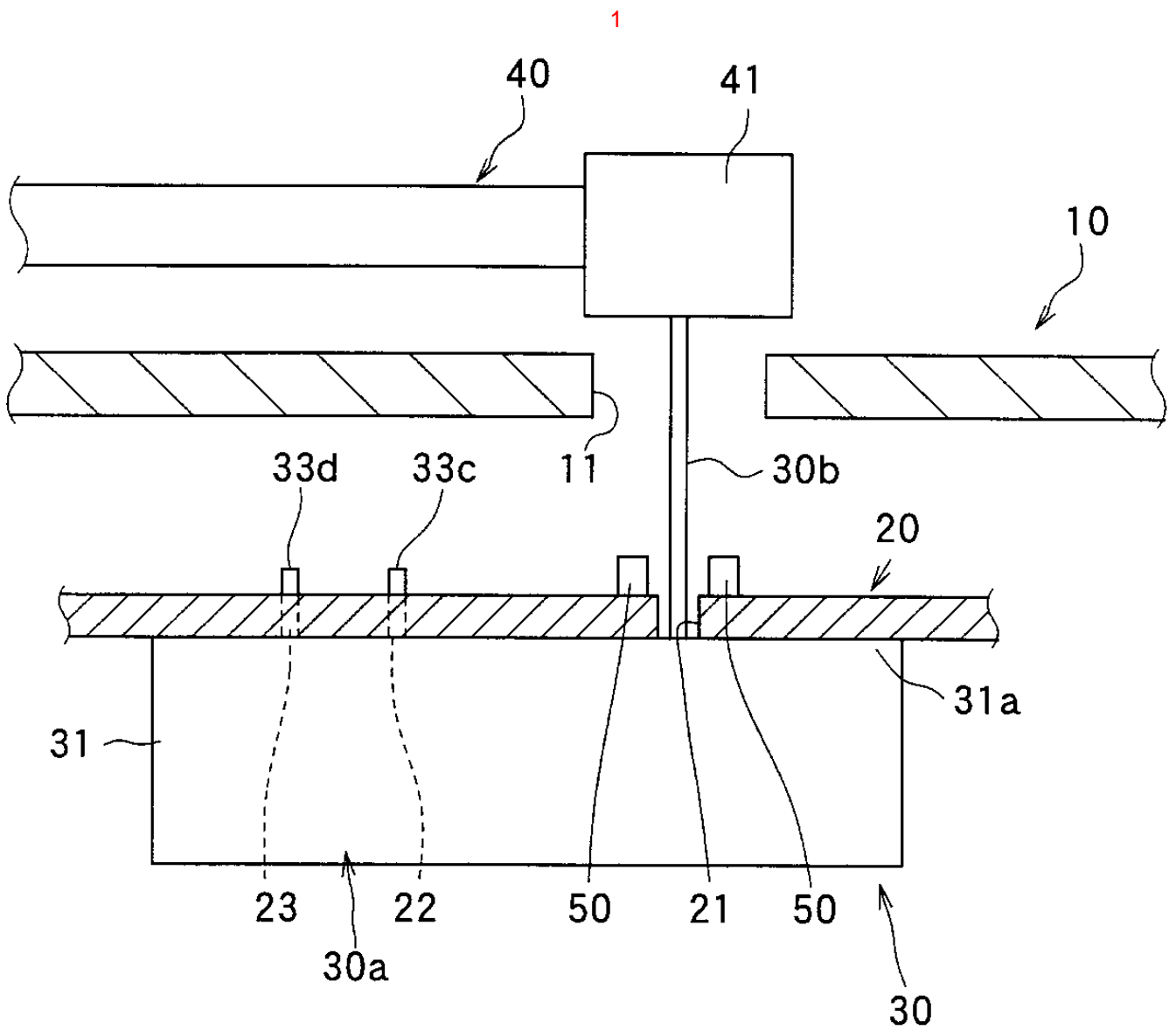

2

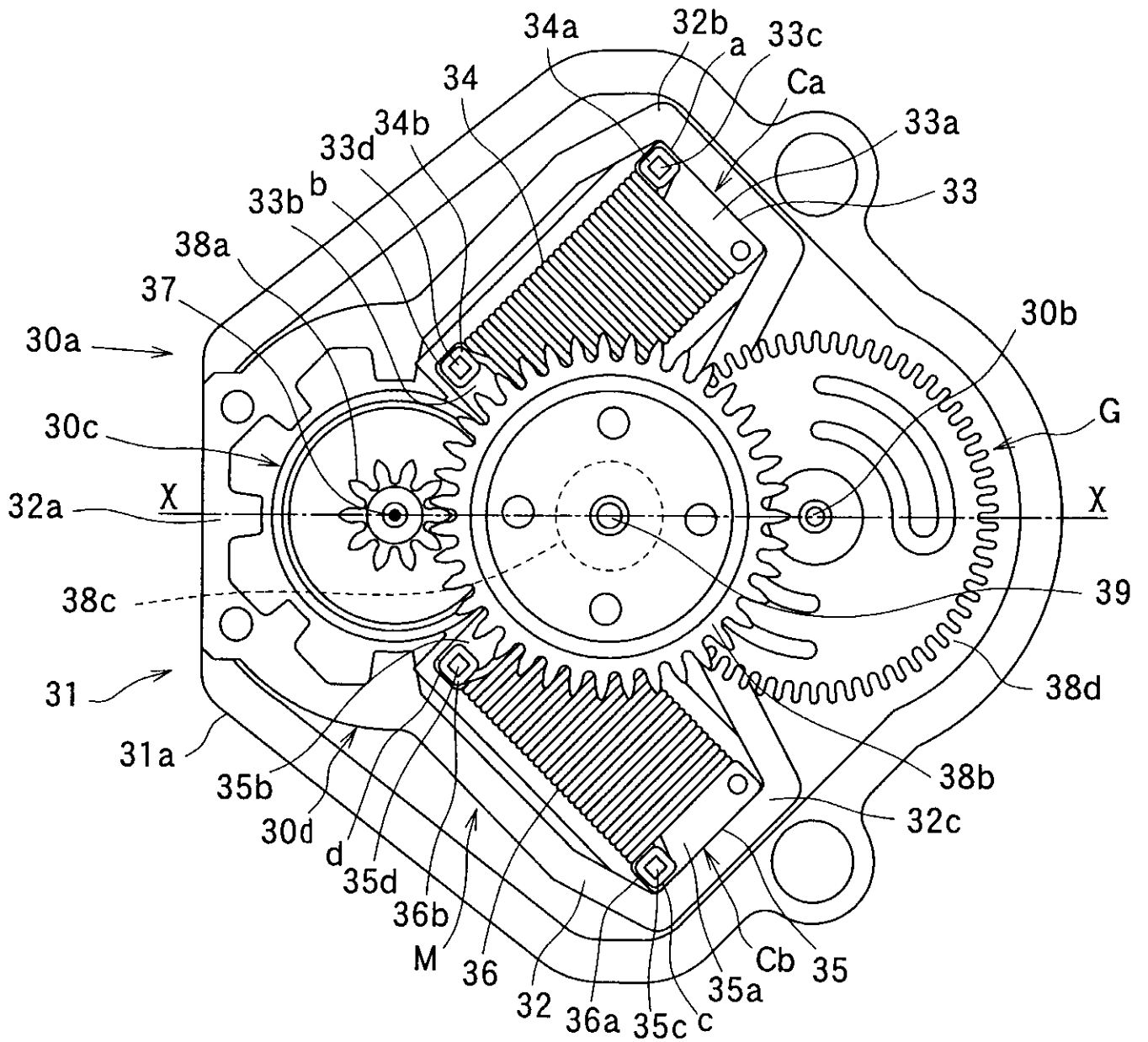

3

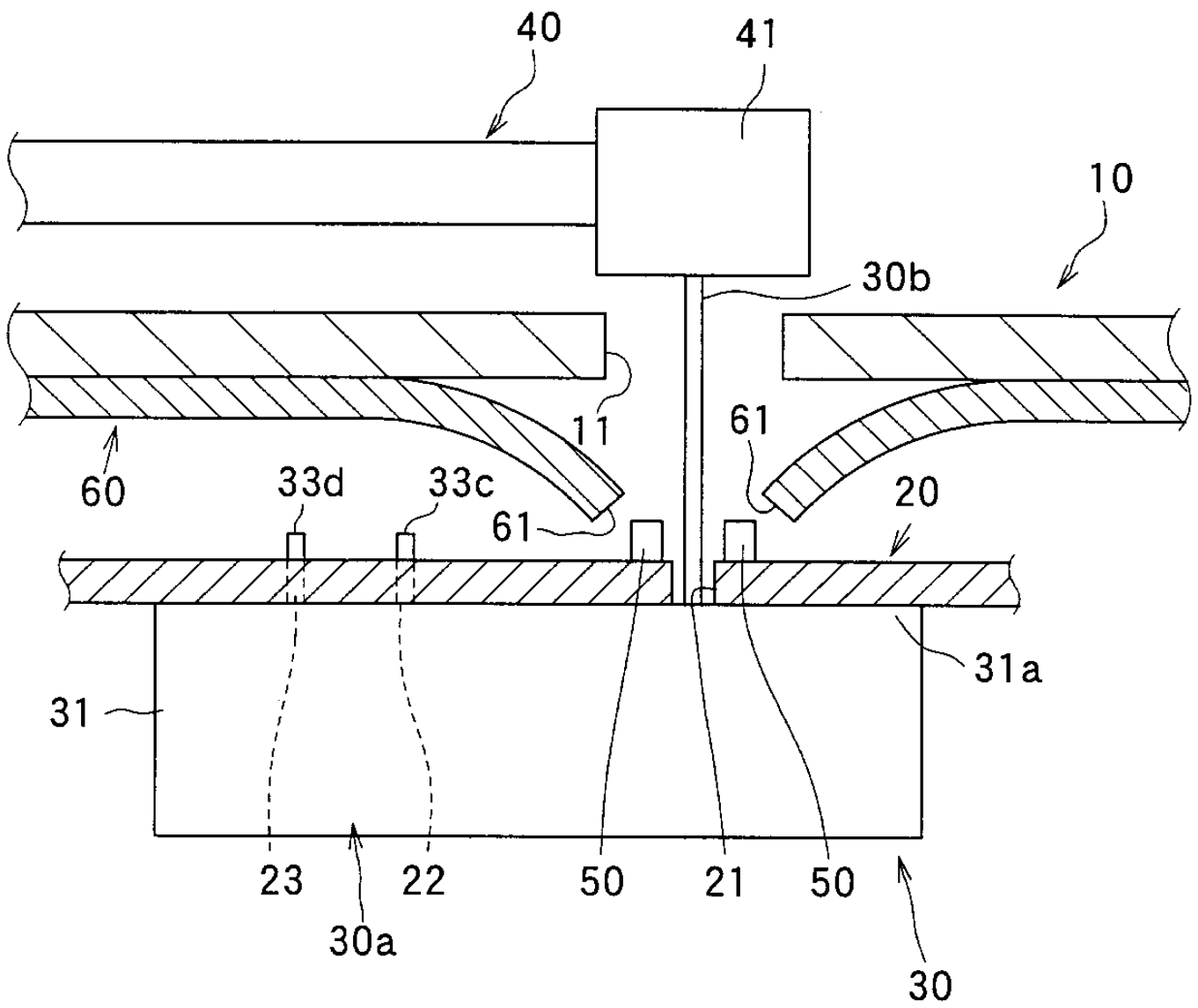

4

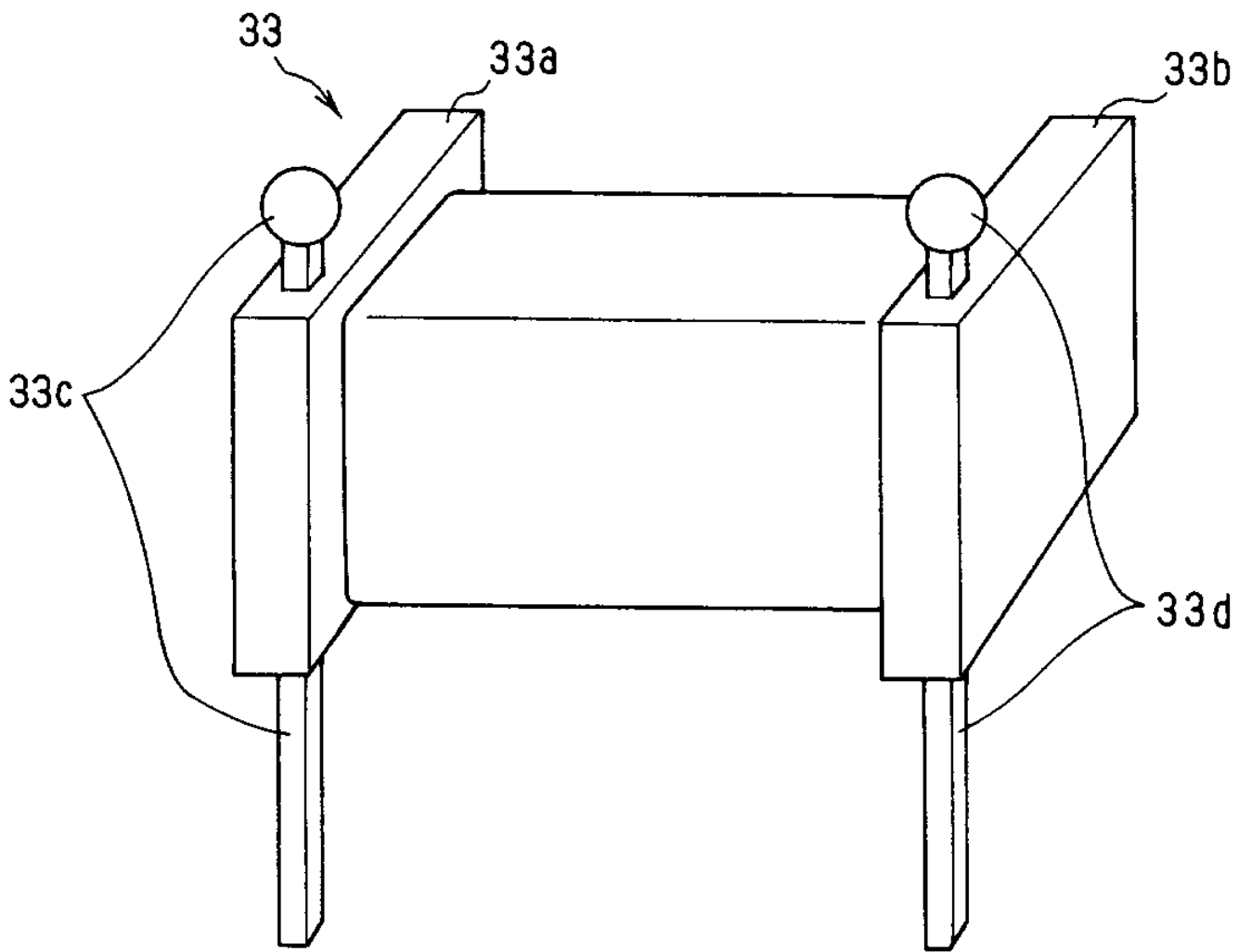

5

