

(19) World Intellectual Property Organization
International Bureau



(43) International Publication Date
5 July 2001 (05.07.2001)

PCT

(10) International Publication Number
WO 01/48505 A2

- (51) International Patent Classification⁷: **G01S 5/00**
- (21) International Application Number: PCT/US00/35205
- (22) International Filing Date:
26 December 2000 (26.12.2000)
- (25) Filing Language: English
- (26) Publication Language: English
- (30) Priority Data:
09/473,213 27 December 1999 (27.12.1999) US
- (71) Applicant: MAIN COURSE TECHNOLOGIES, INC.
[US/US]; 548 South Spring Street, Suite 1030, Los Angeles, CA 90013 (US).
- (72) Inventors: COGGINS, Pat; 1542 Roundup, Norco, CA 91760 (US). WILCOX, Jerry; 16686 Fieldstone Drive, Saratoga, CA 95070 (US).
- (74) Agents: CHEN, Eric, S. et al.; Pillsbury Madison & Sutro LLP, Suite 2800, 725 South Figueroa Street, Los Angeles, CA 90017 (US).
- (81) Designated States (*national*): AE, AG, AL, AM, AT, AU, AZ, BA, BB, BG, BR, BY, BZ, CA, CH, CN, CR, CU, CZ, DE, DK, DM, DZ, EE, ES, FI, GB, GD, GE, GH, GM, HR, HU, ID, IL, IN, IS, JP, KE, KG, KP, KR, KZ, LC, LK, LR, LS, LT, LU, LV, MA, MD, MG, MK, MN, MW, MX, MZ, NO, NZ, PL, PT, RO, RU, SD, SE, SG, SI, SK, SL, TJ, TM, TR, TT, TZ, UA, UG, UZ, VN, YU, ZA, ZW.
- (84) Designated States (*regional*): ARIPO patent (GH, GM, KE, LS, MW, MZ, SD, SL, SZ, TZ, UG, ZW), Eurasian patent (AM, AZ, BY, KG, KZ, MD, RU, TJ, TM), European patent (AT, BE, CH, CY, DE, DK, ES, FI, FR, GB, GR, IE, IT, LU, MC, NL, PT, SE, TR), OAPI patent (BF, BJ, CF, CG, CI, CM, GA, GN, GW, ML, MR, NE, SN, TD, TG).

Published:

— Without international search report and to be republished upon receipt of that report.

For two-letter codes and other abbreviations, refer to the "Guidance Notes on Codes and Abbreviations" appearing at the beginning of each regular issue of the PCT Gazette.



WO 01/48505 A2

(54) Title: WIRELESS/GPS ASSET TRACKING AND MONITORING SYSTEM

(57) Abstract: A system for asset tracking and monitoring including a data server coupled to a wireless network and global information network, a mapping database, a user interface, a plurality of wireless GPS devices having varying data formats. Each wireless GPS device (e.g., GPS/cellular phone, GPS/pager device) is registered in the system (i.e., identified by a unique address or the like). Users log into the system and request the location of the registered device via the global information network (e.g., Internet World wide Web interface). The data server receives GPS position information from the various GPS devices regarding the location of each device. This information can be explicitly polled (i.e., requested) by the data server or automatically sent, by the registered device, to the data server on a scheduled basis. A data converter processes the GPS position information into a common format. The data server then generates a map identified with the location of the device in question. The map is displayed to the user via the Internet (World Wide Web) interface.

WIRELESS/GPS ASSET TRACKING AND MONITORING SYSTEM

Background of the InventionField of the Invention

The invention relates to the field of tracking, monitoring and locating systems and in particular, wireless tracking, monitoring and locating systems. These systems are typically used to identify the location of a remote device and an associated individual or asset. Once the device is located the system plots the location on a map which is viewable by a user at a base station or on a display associated with the remote device.

Description of the Related Art

Asset tracking and monitoring systems are generally useful for identifying the location of any mobile asset or individual. For example, a business owning substantial numbers of mobile equipment (e.g., tractor trailers, containers or the like) may wish to track the location of its assets as they move. Tracking the location of mobile equipment and/or employees allows the business to coordinate its business operations (e.g., to determine the status of deliveries, to assess the availability of vehicles or containers for a new assignment, etc.).

There are several known methods in which the location of a given asset or individual can be identified, for example: LORAN-C, GLONASS or GPS. LORAN-C, or long-range navigation is a radio-navigation system using land-based radio transmitters operated by the United States Coast Guard (in the United States). LORAN-C receivers allow mariners, aviators, and (more recently) those interested in terrestrial navigation to determine their position based on signals they receive. GLONASS, or Global Navigation Satellite System, employs a constellation of active satellites which continuously transmit coded signals in two frequency bands. These signals can be received by users anywhere within range, and enable determination of the location and velocity of the receiver in real time. The system is a

counterpart to the United States Global Positioning System (GPS) and both systems share the similar principles in the data transmission and positioning methods.

GPS, or Global Positioning System, is a satellite-based navigation system consisting of a network of 24 orbiting satellites approximately eleven thousand nautical miles in space and in six different orbital paths. The satellites are constantly moving and make approximately two complete orbits around the Earth per day. GPS satellites are commonly referred to as NAVSTAR satellites.

GPS satellites transmit a signal containing a 'pseudo-random code' ephemeris, and almanac data. The transmission identifies which satellite is transmitting and contains information including the status of the satellite (healthy or unhealthy), current date and time. The almanac data defines the location where the GPS satellite should be at any particular time. Each satellite transmits almanac data showing the orbital information for the transmitting satellite and for the other satellites in the system.

A GPS receiver can be structured in two basic forms. In one form, the GPS receiver contains the receiver and a processor with associated programming information sufficient to triangulate its position, that is, to resolve according to some coordinate scheme the unique location or measured position of the receiver. In another form, the GPS receiver may transmit the raw information received from the GPS satellites to an associated base station having a processor and the associated programming information necessary to triangulate the receiver's position.

A GPS receiver and/or base station, upon receiving data from a given satellite compares the time a signal was transmitted by the satellite with the time it was received by the GPS receiver. The time difference tells the GPS receiver and/or base station the

receiver's distance from that particular transmitting satellite (resolving a spherical surface concentric with the transmitting satellite). The receiver and/or base station then similarly calculates distance measurements from at least two other satellites and triangulates the receiver's position to resolve a point of intersection of spheres. The GPS receiver and/or
5 base station can determine the receiver's latitude, longitude and altitude. By continuously updating its position, a GPS receiver and/or base station can also determine the receiver's speed and direction of travel (i.e., ground speed and ground track).

GPS is currently used in recreational applications as well as military and commercial applications. For example, hikers, hunters and the like can use GPS to keep track of their
10 location or to identify their speed and direction. In order to be useful, the location information must be referenced to some sort of coordinate system that is comprehensible to the user.

The functions of a GPS receiver and a cellular telephone can be combined to provide both location and communication functions to the user. For example the NAVTALK,
15 manufactured by GARMIN International, Inc. of Olathe, Kansas combines an analog cellular telephone (AMPS) and a GPS receiver (typically used as outdoor survival gear).

Combinations of GPS receivers and wireless pagers are also known. Generally, such devices are used to report location information to the person carrying the receiving device such that the person can move to a desired destination or find a way out of unfamiliar territory, etc.

20 Asset tracking and monitoring systems have been developed to rely on GPS location information. U.S. Patent No. 5,742,233, issued to Hoffman et al., discloses a personal tracking system and is hereby incorporated by reference. The system uses a portable signaling unit that communicates wirelessly (GPS) to a central dispatch station. A user wears

the portable signaling unit and activates the signaling unit in an emergency. The signals transmitted from the portable unit are received at the central dispatch. The central dispatch displays the location of the portable unit on a digital map along with other information. The central dispatch can also trigger the portable unit to report its location, thus allowing the base station to monitor the locations of its portable units.

U.S. Patent No. 5,712,899, issued to Pace II shows a mobile location reporting system which utilizes a combined mobile cellular telephone and GPS unit for communicating with a base station. The mobile unit receives GPS information and subsequently transmits this information to the base station. The base station resolves the GPS information into geographic location information and generates a map showing the location of the mobile unit. The base station as well as the mobile unit are operable to display the map information.

U.S. Patent 5,771,001, issued to Cobb shows a cellular based personal alarm system which can monitor the vital statistics (i.e., blood pressure, pulse rate, body temperature and the like) of an individual at a remote location. The system uses a portable transmitter which transmits cellular telephone based signals representing the vitals statistics as well as the location of the individual. A home receiver (i.e., base station) having a cellular based electronic receiver detects and receives the cellular signals and displays the vital statistics and location information.

GPS geographical location information in its raw form is essentially timing and ranging information. This information is converted by triangulation to a unique point and the point is located in a three dimensional coordinate system. In order to be meaningful and useful, the location information derived for the GPS receiver must be related to a coordinate system that sufficiently familiar to the user that the user can relate the location of a receiver

to other locations that are remote from the receiver, such as the locations of landmarks or other receivers. Latitude - longitude - altitude information may not be the most meaningful type of presentation in that regard. It is known to relate GPS information to graphic maps to address this need. U.S. Patent 5,959,577, issued to Fan et al., shows a method for processing 5 travel related information through a data processing station on a data network and is hereby incorporated by reference. A mobile GPS receiver obtains location information and subsequently transmits this information to the base station. The base station computes a measured position (i.e., performs triangulation in a coordinate system) and generates a map showing the location of the GPS receiver. The map can be transmitted in digital form to a 10 user via a data network such-as the Internet. In that case it is possible but not required (or perhaps likely) that the “user” is disposed at the location of the GPS receiver.

In such a system, numerous details are predetermined and must be adhered to if useful information is to result. There are specific formatting and timing requirements for timing data reception and for data reporting. Any communications must be formatted as 15 expected by the respective receiver or transponder. The various details could include, for example, the modulation technique, frequency, bit rate, number of bits, parity, checksum and other details. According to different designs, the nature of the data could vary from one application to another. The coordinates used, the nature of the display, the resolution, and many other specific attributes are predetermined. Thus all the component parts of the GPS 20 system are generally supplied as a unit or according to the specifications of a single service providing organization.

The Fan patent recognizes that different types of GPS receivers are in use. In one possibility mentioned, the GPS receiver triangulates its position and transmits its measured

position to the base station. In another possibility, the GPS receiver transmits pseudoranges and the base station calculates a measured position via triangulation. These possibilities are mutually exclusive. In order to function, the receiver and the base station of the particular system must both send and receive the form of data that is expected. Even assuming use of the same communication path and assuming that all the data necessary to resolve and display location information is present, a system designed to receive a different form of data will be unable to extract or process data that is not in the expected form. Fan does not disclose a structure or method for dealing with potential variation in the form of data or the method of its communication. It would be advantageous if such variation were to be accommodated.

Other systems such as military applications disclose various combinations of transmitters, receivers and base stations for identifying the location of remote personnel and equipment. See for example, U.S. patent 5,625,363 - Spilker and U.S. Patent 5,726,663 - Moyer et al. However they may be embodied, such systems also naturally are based on the proposition that sending and receiving elements in data communication are operating with the same expectations as to the nature of the data sent, received, processed, displayed, etc.

Thus a user who wishes to operate a GPS receiver is required to obtain and operate the specific type of GPS receiver supported by the base station. It would be desirable to provide a base station capable of supporting a wide range of GPS receivers. Thus, the user would be free to select the type of GPS receiver that best suits its needs. For example, a user may wish to purchase a pager based unit (i.e., relatively inexpensive and small) for one application and a more elaborate cellular based unit (i.e., more expensive and larger) for another application.

Another difficulty with known systems is the need for a base station in order to monitor the location of remote individuals or assets. Base stations typically include a digital processor, associated software including a mapping database and a wireless transmitter/receiver. Base stations are relatively costly and require periodic maintenance (e.g., software revisions, updates and/or corrections to the mapping database).

Known base stations are also specifically designed to work with a single type of remote transmitter with a specific data format and wireless capability. Thus, a user must replace either the entire base station or the cellular transmitter/receiver when upgrading communications capabilities of the base station. It would be desirable to provide remote monitoring capabilities to users without the need for a user owned and maintained base station.

Summary of the Invention

The invention provides for a new and novel system for asset tracking and monitoring, and generally includes a data server (i.e., host computer and associated software) coupled to a wireless network and global information network, a mapping database, a user interface, a plurality of wireless GPS devices. Each wireless GPS device (e.g., GPS/cellular phone, GPS/pager device) is registered in the system (i.e., identified by a unique address or the like). Users log into the system and request the location of the registered device via the global information network (e.g., Internet World Wide Web interface). The data server receives GPS position information from various GPS devices regarding the location of each device. This information can be explicitly polled (i.e., requested) by the data server or automatically sent, by the registered device, to the data server on a scheduled basis. A data converter processes the GPS position information into a common format. The data server then

generates a map identified with the location of the device in question. The map is the displayed to the user via the Internet (World Wide Web) interface.

Brief Description of the Drawings

There are shown in the drawings certain exemplary embodiments of the invention as
5 presently preferred. It should be understood that the invention is not limited to the
embodiments disclosed as examples, and is capable of variation within the scope of the
appended claims. In the drawings,

FIGURE 1 shows a schematic diagram of a wireless/GPS asset tracking and
monitoring system in accordance with the invention;

10 FIGURE 2 is a flow chart of the data server software;

FIGURE 3 is a flow chart showing a more detailed description of blocks 56 and 58 as
identified by A and B of Figure 2

FIGURE 4 is an data diagram of exemplary data from a wireless GPS device in
accordance with the invention.

15 Detailed Description of the Preferred Embodiments

The invention concerns a wireless/GPS asset tracking and monitoring system. The
system generally includes a data server (i.e., host computer and associated software) coupled
to a wireless network and global information network, a mapping database, a user interface,
and a plurality of wireless GPS devices. Each wireless GPS device (e.g., GPS/cellular
20 phone, GPS/pager device) is distinct in the system (e.g., identified by a unique telephone
number, IP address, serial number or combination of designations useful to distinguish that
device from other operating devices). Users log into the system and request the location of a
specific (e.g., registered) device via the global information network (e.g., Internet World

Wide Web interface). The data server receives GPS position information from the various GPS devices in various forms. This information generally identifies directly or indirectly the measured position or location of the registered device. This position information can be explicitly polled (i.e., requested) by the data server or automatically sent, by the registered
5 device, to the data server on demand or on a scheduled basis or upon the occurrence of some event. The data server receives this information via the wireless network or the Internet and generates an appropriate map identified with the location of the device in question. The map is the displayed to the user via the Internet (World Wide Web) interface.

The term “wireless GPS device” as used herein refers to a combined GPS receiver
10 and a wireless transmitter. The term “wireless GPS device” also encompasses a combined GPS receiver and a wireless receiver/transmitter. The GPS receiver receives geographical location information from several GPS satellites. Some wireless GPS devices triangulate their position and transmit measured position information (or location) to the data server.

The term “geographical location information” refers to the information received from
15 one or more GPS satellites. This information is in a “raw” form and generally includes a ‘pseudo-random code’, or ephemeris and almanac data. The pseudo-random code identifies which satellite is transmitting. Ephemeris data is constantly transmitted by each satellite and contains various types of information including the status of the satellite (healthy or unhealthy), current date, and time. The almanac data tells the GPS receiver where each GPS
20 satellite should be at any time throughout the day. Each satellite transmits almanac data showing the orbital information for that satellite and for the other satellites in the system. Further processing is required to derive a specific measured position or location for a given GPS receiver (i.e., latitude, longitude and altitude). Some GPS devices transmit unprocessed

or partially processed geographic location information. In this case, the data server calculates a measured position via known triangulation techniques.

The term "wireless network" is used in its broadest sense and includes typical analog and digital cellular networks (e.g., AT&T, Bell Atlantic, CellularOne, GTE), pager networks (e.g., Mobitex) and the like. Each of the wireless GPS devices transmits measured position information (or geographical location information) to the data server via the wireless network. The term "wireless network" also includes general satellite data transmission (for those devices having a satellite based ground station as discussed in more detail below). In this sense, the term "wireless" denotes that the wireless GPS devices are not fixed at any given location by a necessary communication connection as characterized by a situation in which devices are associated to a location by permanent connections of one form or another.

Figure 1 shows an exemplary schematic diagram of a wireless/GPS asset tracking and monitoring system. The system is operable to identify the location of a variety of different wireless GPS devices 10. Each of the wireless GPS devices receive geographical location information from several GPS satellites 12. The wireless GPS device transmits the geographical location information or measured position information to the data server 14 for conversion and/or map generation.

One type of currently available wireless GPS device is the NAVTALK, manufactured by GARMIN International, Inc. of Olathe, Kansas, which combines an analog cellular telephone (AMPS) and a GPS receiver. The NAVTALK includes the capability to triangulate its measured position as well as the capability to transmit its measured position via a series of touch-tones (i.e., Dual Tone Multi-Frequency or DTMF) on a wireless network (AMPS cellular network). The NAVTALK can be configured to periodically transmit

measured position or can be expressly polled by the data server 14. In order to minimize cellular usage, it is preferable that the data server poll the NAVTALK unit for its current location only upon a user request. In this case, the data server is operable to receive the measured position information from the NAVTALK via the wireless network using a DTMF
5 receiver or the like. The DTMF receiver is generally known in the art of telephony and converts the series of DTMF tones into digital data representing the measured position.

Another type of currently available wireless GPS device is the Magellan GSC-100, manufactured by the Magellan Corporation of Santa Clara California. The GSC-100 accesses the ORBCOMM satellite constellation and also provides integrated positioning and
10 navigation capabilities using the Global Positioning System (GPS) constellation. Unlike traditional land-line, cellular, or paging systems, the ORBCOMM satellite network facilitates communication to and from isolated parts of the world where conventional systems do not reach. The GSC-100 has an associated ground station 16 which is coupled directly to a global data network, Internet 18 (i.e., each GSC-100 is assigned its own Internet IP address).
15 The GSC-100 is preferably polled by the data server to obtain current location information. The data server 14 communicates with the GSC-100 base station via Internet e-mail in a proprietary format.

Another type of currently available wireless GPS device is the AirLink PINPOINT, manufactured by AirLink Communications, Inc. of San Jose, California. The PINPOINT
20 integrates a Cellular Digital Packet Data (CDPD) modem with a Global Positioning System (GPS) receiver to provide location information to mobile applications. CDPD is an efficient and secure wireless packet data technology that suited for sending and receiving messages to and from untethered applications. Each PINPOINT unit is associated with a ground station

and has a full time Internet IP address. The data server communicates with the PINPOINT via UPD (Unconnected Data Packets) in a proprietary format.

Other types of currently available wireless GPS devices include the CROSSCHECK family of products, manufactured by Trimble Navigation of Sunnyvale California. The
5 CROSSCHECK AMPS Cellular unit integrates GPS, a wireless cellular unit (AMPS) and computing technologies onto a mobile unit. The CROSSCHECK XR unit integrates GPS, cellular protocol support and computing power into a mobile unit ideal for integration with a separate cellular modem. When combined with an external radio, the CROSSCHECK XR allows the flexibility to function with a number of communications protocols including GSM
10 and transparent data.

CROSSCHECK units can be configured to automatically report its location (e.g., based on an external events such as time, distance traveled, vehicle ignition on or off ...). CROSSCHECK units contain an internal modem and generally communicates with the data server via standard ASCII data (as opposed audio and DTMF tones). The ASCII data
15 transmitted by CROSSCHECK units is also in a proprietary format and must be decoded by the data server.

Yet another type of currently available wireless GPS device is the RIM 950 pager. This device can be associated with NMEA compliant GPS receiver and subsequently transmit its measured position via a wireless network.

20 Other wireless location devices are acceptable for use with the invention. Including Internet enabled cellular phones and the like. These devices obtain position information via GPS or analogous sources and communicate via the wireless network. These devices may

also be associated with a ground station so that information measured position can be obtained via the Internet.

Each of the wireless GPS devices set out above perform triangulation internally and transmit measured position via a wireless network, although the system could be configured to perform triangulation at the data server. Each of the GPS devices transmit the measured position via a proprietary format which must be decoded by the data server. The decoding of this proprietary information is set in more detail below.

As shown in Figure 1, data server 14 is coupled in data communication with a wireless network 20 and a global data network (e.g., Internet 18). Preferably, the data server is a digital computer (with associated RAM, ROM, mass data storage devices, video display, input devices and the like) and an associated operating system (such as MICROSOFT WINDOWS, UNIX, LINUX or the like). The data server has a user interface 22, accessible by users via the Internet (i.e., World Wide Web page). The data server also has a user list 24, map database 26 and data converter 28 for translating the proprietary information from the various wireless GPS devices into a common format for use with the map database 26. The map database 26 is used to generate a map for display to users 30 via the Internet using a conventional web browser (not shown).

Figure 2 shows a flow chart of the basic operation of the data server user interface. Figure 2 shows only the basic topology as it pertains to providing a user with a User Id or the location of a specific wireless GPS device. For matters of simplicity, Fig 2 is generally shown as a programming loop. It is understood that other functions are performed by the data server and user interface and that various error checking and maintenance routines and the like must be provided (i.e., invalid password, duplicate User ID, report generation and the

like). It is also understood that it is possible and/or necessary to exit the programming loop under certain circumstances. However, these aspects of the operation of the user interface are routine and fully appreciated by those skilled in the art of basic computer programming.

In order to access the system, the user must obtain a User ID from the data server 14.

5 The user must also identify the specific device to be tracked by the system. In general, the user accesses the system via the Internet using a typical web browser. Initially, The data server prompts for a User ID (and associated password), block 40. The data server searches the user list 24 for a match, see block 42. If the User ID is not contained in the user list, control is passed to block 44 and the system requests further information from the user (i.e.,
10 name, address, phone number, e-mail address and the like). The user is then assigned a User ID (i.e., the information is stored in the user list), block 46. The particular User ID is preferably selected by the user.

The user is then queried for information on the first wireless GPS device they wish to register in the system, block 48. The system requests information necessary for identifying
15 the device (i.e., make and model of device, IP address, phone number or the like). The wireless GPS device is assigned a Device ID, block 50. This information is also stored in the user list 24. The user interface requests if additional devices are to be identified (block 52), and if so, control is passed back to block 48 until all devices are identified or registered. If no further devices are to be entered, control is passed back to the start.

20 In the case of existing users, the system identifies that the User ID provided at block 40 is in the user list 24, see block 42. Control is passed to block 54 and the system prompts for the Device ID. Since the Device ID is already present in the user list, the data server can identify the type of wireless GPS device in question (i.e., make and model, IP address,

telephone number, propriety data format etc., etc.), block 56. The data server then obtains the location of the wireless GPS device, block 58. A map is then generated and displayed to the user, block 60. The system queries whether the user wishes to identify the location of other devices (block 62), if so control is passed to block 54. Otherwise, control is passed
5 back to the start.

Figure 3 shows a more detailed description of blocks 56 and 58 as identified by A and B of Figure 2. Based on the device type, the data server obtains the measured position from the proper source and converts the data appropriately.

For non-pollled devices (i.e., automatically or periodically updated), the data server
10 maintains a current position of each registered device (e.g., associated with the user list). See blocks 70 and 72. The position information stored in the data server memory for these devices and is preferably in the proper format for interfacing with the mapping database. In the alternative, the data can be converted as discussed in more detail below.

Polled devices fall into several categories as discussed above. For example,
15 NAVTALK units communicate with the data server directly via the cellular network (i.e., via DTMF tones). See block 74. In this case, the Device ID is the NAVTALK cellular number. The data server places a call to the particular NAVTALK unit and queries the unit for its current location. The measured position of the unit is returned via audio DTMF tones in a proprietary format, block 76. Thus the measured position must be decoded by data decoder
20 28, as generally shown by block 78. An example of the decoding process is set forth in more detail below.

UPD based devices such as the AirLink PINPOINT communicate the data server 14 via UPD (Unconnected Data Packets) in a proprietary format. Each PINPOINT unit is

associated with a ground station 16 and has a full time Internet IP address. The data server communicates with the PINPOINT directly via the Internet without placing a cellular call or communication via a wireless network, see blocks 80 and 82. Thus, the PINPOINT unit communicates wirelessly only with its associated ground station (maintained independently of the disclosed system). Similarly, the measured position must be decoded by data decoder 28, as generally shown by block 84.

E-mail based devices such as the Magellan GSC-100 also has an associated ground station 16 which is coupled directly to the Internet 18 (i.e., each GSC-100 is assigned its own Internet IP address). The data server 14 communicates with the GSC-100 base station via Internet e-mail in a proprietary format. See blocks 86 and 88. Similarly, the measured position must be decoded by data decoder 28, as generally shown by block 90. If the device does not fall into one of the categories, an error condition exists as shown generally at block 92.

Figure 4 shows the basic format for the Trimble CROSSCHECK family of wireless GPS devices. A CROSSCHECK AMPS unit includes a modem for communication with the data server via the cellular (AMPS) wireless network. The measured position must be decoded by data decoder 28, as generally shown by block 78 (figure 2).

As shown in Figure 4, a typical event message transmitted by the CROSSCHECK unit is a series of ASCII characters (in this case the EV short format event message, 36 characters in length). A complete listing of the CROSSCHECK message protocol is contained in the TAIP/IQ Event Engine Reference, Version 1.0, Revision B, August 1999, Trimble Navigation Limited and is available from the Trimble Internet Web Site (<http://www.trimble.com>).

The first 12 characters (i.e., AABBBBCDDDD) pertain to information beyond the scope of this application. The next 23 characters (i.e., EEEEEFFFGGGGHHHHHJJJK) are of particular importance and contain the latitude, longitude, speed and heading. The latitude and longitude information are provided in WGS-84 format. Decoder 28 strips this portion of the event message and converts it into measured position data in a common format for use in conjunction with the mapping database

The measured position information used to generate a map showing the location of wireless GPS device in question. Various types of mapping databases are suitable for use in conjunction with the invention. For example, standard mapping databases are available from Environmental Systems Research Institute, Inc. of Redlands California. These databases are generally linked to the data server software and generate mapping information based on a known format such as SHP (or shape file format). Once the data from the various wireless GPS device is decoded from their respective proprietary formats, conversion to a common format (such as SHP) is routine and generally known in the art.

The user is then presented with a map showing the location of the registered device. The user can also be presented with various other options such as the ability to pan and zoom the mapping information to suit their needs.

The invention having been disclosed in connection with the foregoing variations and examples, additional variations will now be apparent to persons skilled in the art. The invention is not intended to be limited to the variations specifically mentioned, and accordingly reference should be made to the appended claims rather than the foregoing discussion of preferred examples, to assess the scope of the invention in which exclusive rights are claimed.

Claims

1. A wireless asset tracking and monitoring system for providing a user of a global information network with location information from a geographical location system via a wireless network and a global information network, the system comprising:

5 at least one wireless remote receiver/transmitter unit having geographical location information receiver, a wireless network receiver/transmitter an associated address, the wireless remote receiver/transmitter unit receiving geographical location information from the geographical location system and transmitting at least one of geographical location information in a first format and measured position in a first format via the wireless network;

10 a data server having a wireless network data communications channel and a global information network data channel, the data server receiving via one of the wireless network and global information network, at least one of the geographical location information in the first format and measured position in a first format from the first remote receiver/transmitter unit;

15 a data converter operable to convert data in at least two different formats into a common format, the data converter being operable to convert at least one of the geographical location information in the first format and measured position in a first format into measured position data in a common format;

20 wherein the data server has a user interface associated with the global information network for providing the measured position in the common format to the global information network user via the global information network.

2. The system of claim I further comprising a second wireless remote receiver/transmitter unit having geographical location information receiver, a wireless

network receiver/transmitter an associated address, the wireless remote receiver/transmitter unit receiving geographical location information from the geographical location system and transmitting at least one of geographical location information in a second format and measured position in a second format via the wireless network.

5 3. The system of claim 1 further comprising a mapping database in data communication with the data server wherein the data server retrieves mapping information from the mapping database based on the measure position data in the common format, wherein the mapping information is provided to the user via the user interface.

 4. The system of claim 1 wherein the geographical location system is GPS.

10 5. The system of claim 1 wherein the wireless remote receiver/transmitter unit is a GPS receiver and at least one of a cellular telephone and a pager.

 6. The system of claim 1 wherein the global information network is the Internet and the user interface is an Internet world wide web server.

 7. The system of claim 1 further comprising a user list in data communication
15 with the data server wherein the user list contains a User ID associated with the user and the unique address of the wireless remote receiver/transmitter unit, wherein the user interface prompts the user for the user ID, verifies that the user ID is valid and provides the geographical location information to the user via the global information network.

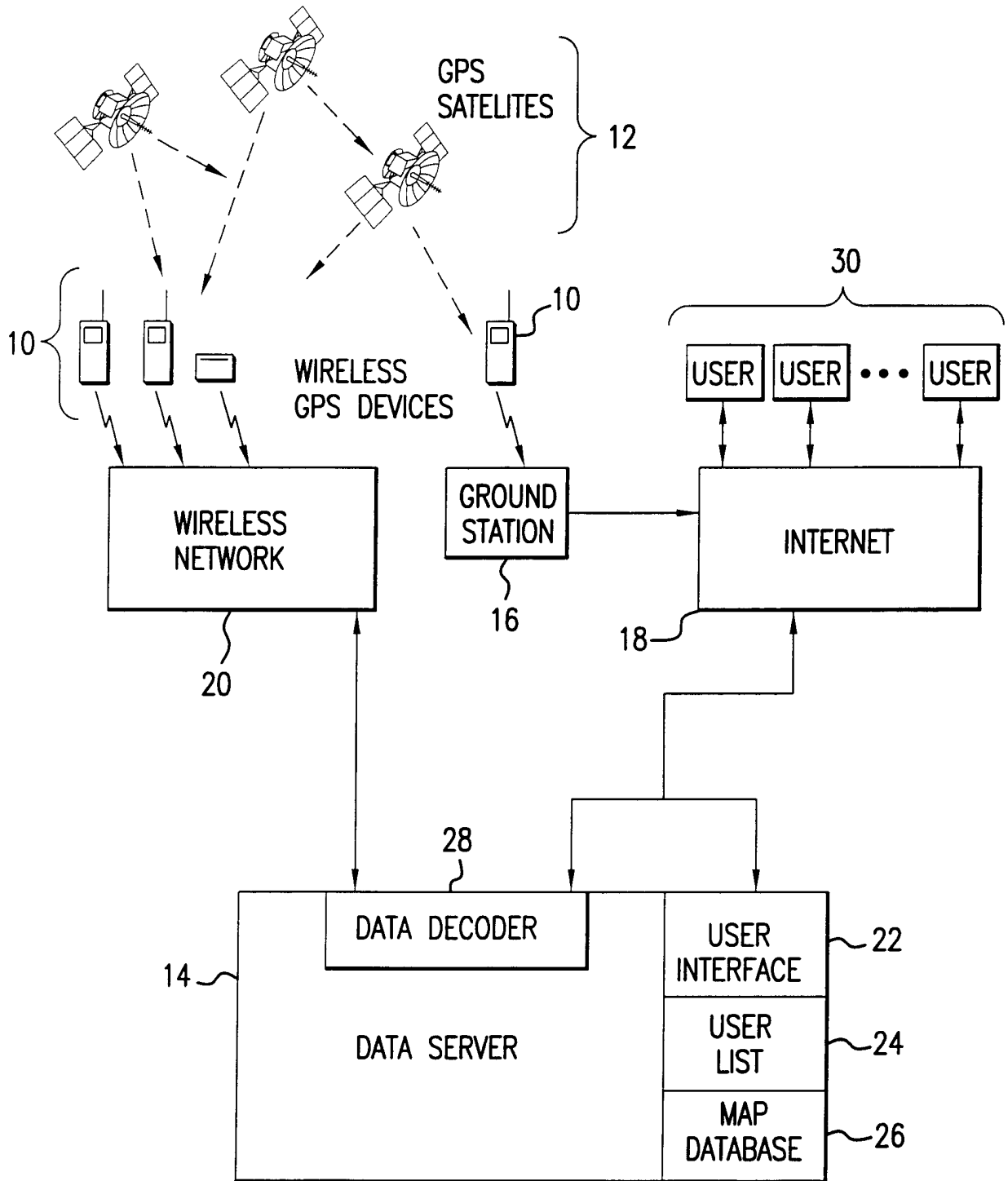

FIG.1

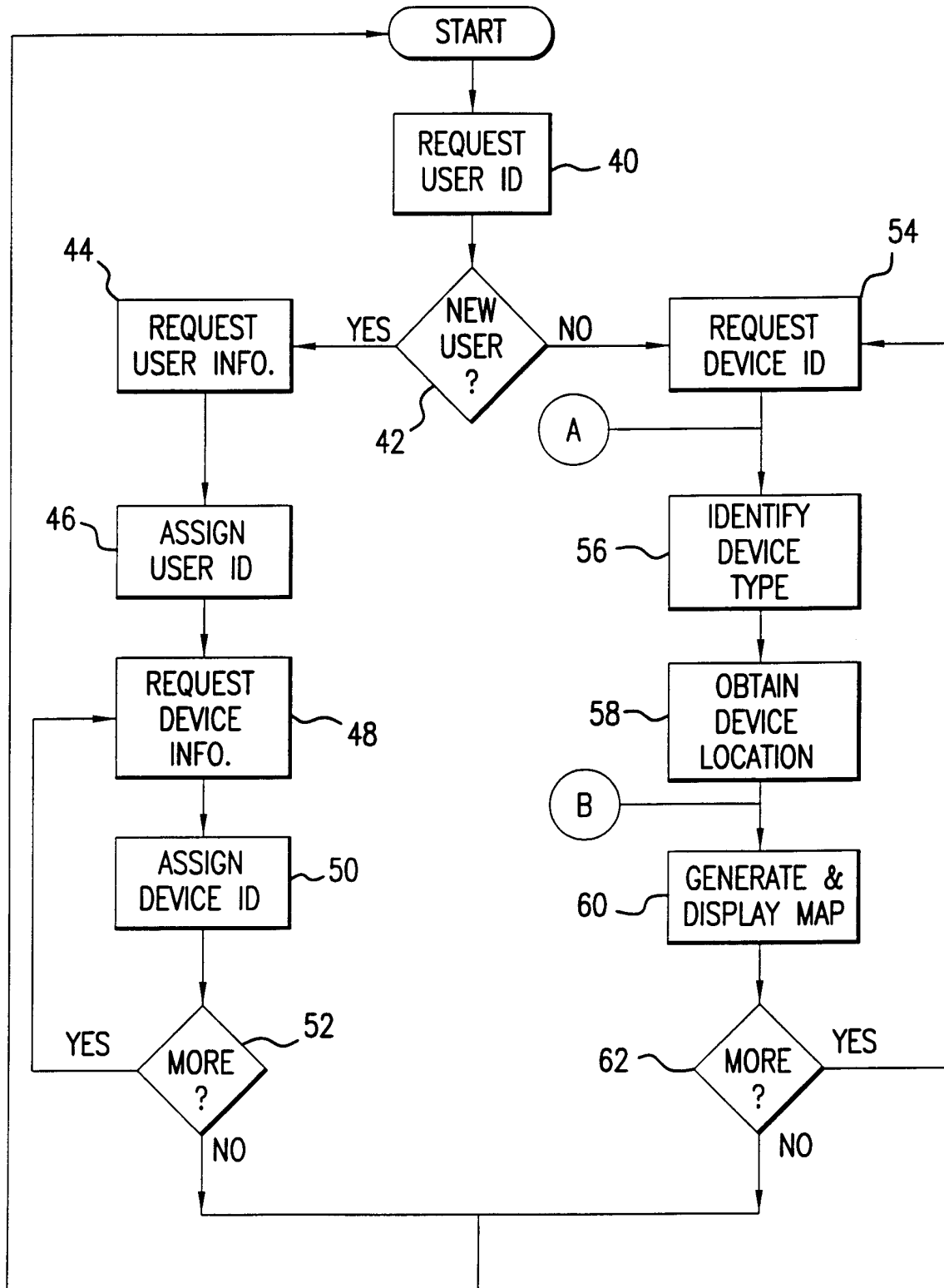

FIG.2

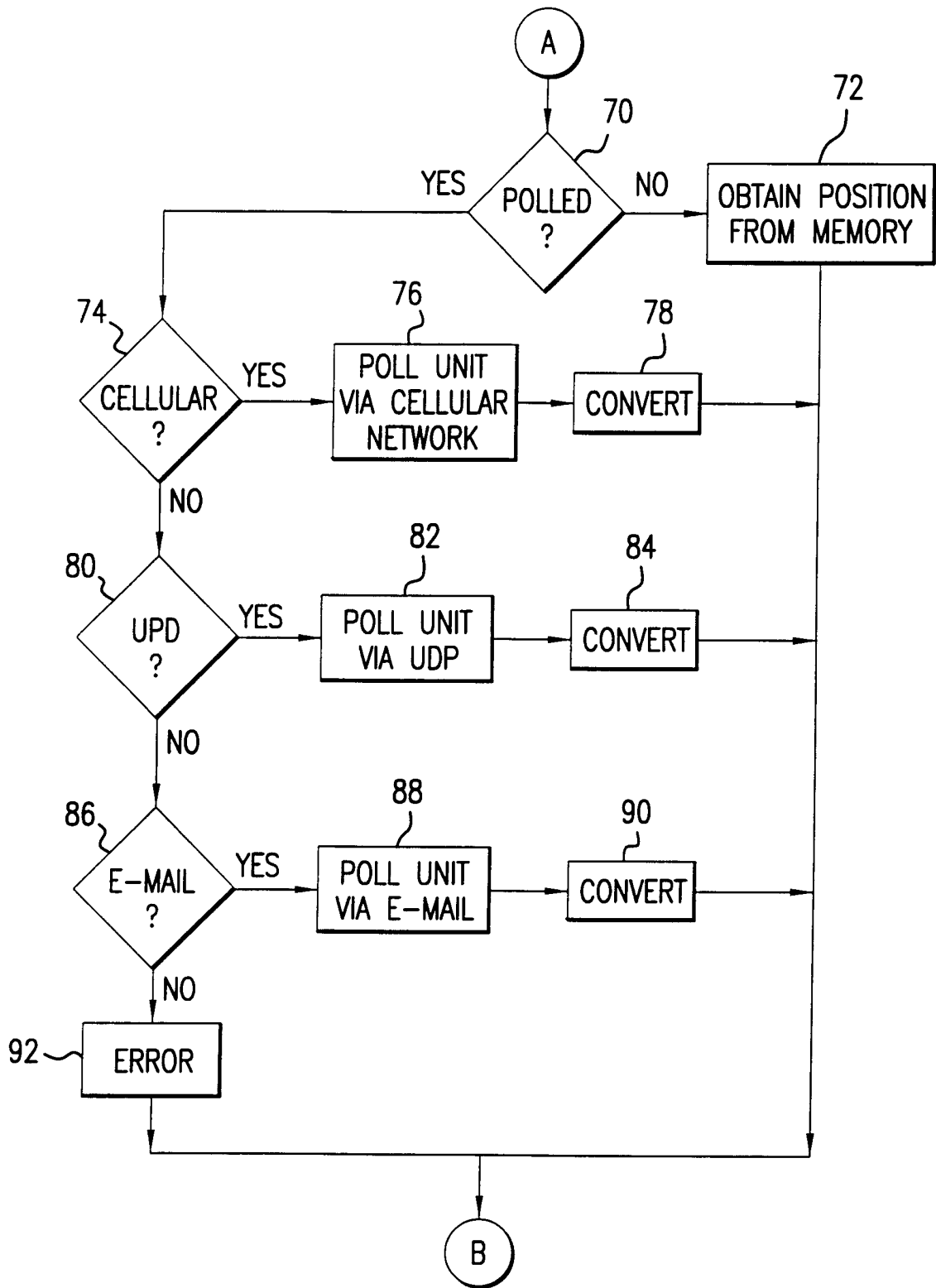

FIG.3

Data Format:

AABBBCDDDEEEFFGGHHHIIJJK

Where:

- AA - Event ID
- BBBB - Week Number
- C - Day of the Week
- DDDDD - GPS Time or Event Time
- EEE.FFFFF - Latitude (WGS-84 Latitude coordinate - positive = north)
- GCGG.HHHHH - Longitude (WGS-84 Longitude coordinate - positive = east)
- III - Speed (Mph)
- JJJ - Heading (Degrees)
- K - Data source

FIG.4