

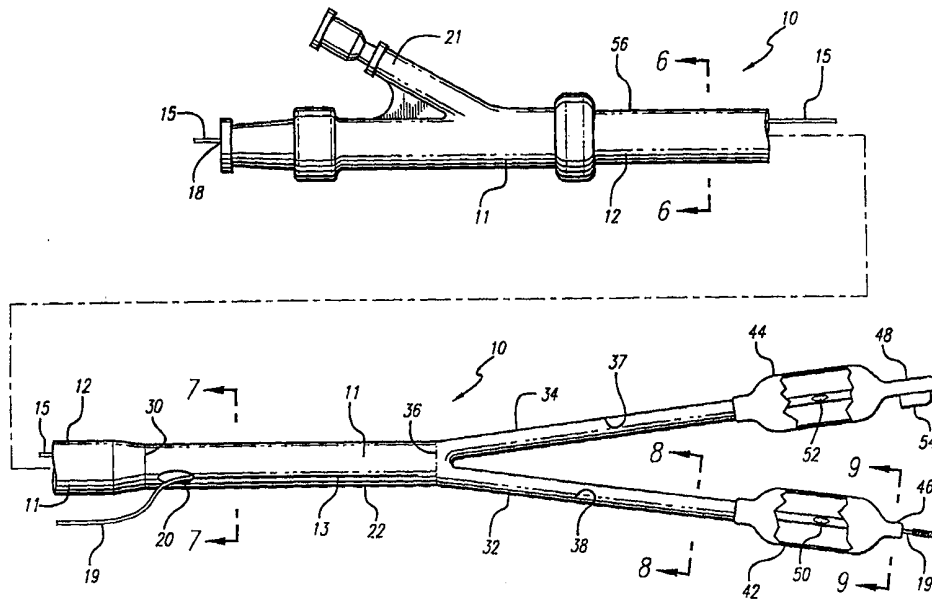

INTERNATIONAL APPLICATION PUBLISHED UNDER THE PATENT COOPERATION TREATY (PCT)

<p>(51) International Patent Classification ⁷ : A61F 2/06</p>	<p>A1</p>	<p>(11) International Publication Number: WO 00/10489 (43) International Publication Date: 2 March 2000 (02.03.00)</p>
<p>(21) International Application Number: PCT/US99/19127 (22) International Filing Date: 24 August 1999 (24.08.99) (30) Priority Data: 09/138,844 24 August 1998 (24.08.98) US (71) Applicant: ADVANCED CARDIOVASCULAR SYSTEMS, INC. [US/US]; 3200 Lakeside Drive, Santa Clara, CA 95054-8167 (US). (72) Inventor: MAUCH, Kevin, M.; 782 Hamann Drive, San Jose, CA 95117 (US). (74) Agents: MAHER, Pamela, G. et al.; Fulwider Patton Lee & Utecht, LLP, 10th floor, 10877 Wilshire Boulevard, Los Angeles, CA 90024 (US).</p>		<p>(81) Designated States: AE, AL, AM, AT, AU, AZ, BA, BB, BG, BR, BY, CA, CH, CN, CU, CZ, DE, DK, EE, ES, FI, GB, GD, GE, GH, GM, HR, HU, ID, IL, IN, IS, JP, KE, KG, KP, KR, KZ, LC, LK, LR, LS, LT, LU, LV, MD, MG, MK, MN, MW, MX, NO, NZ, PL, PT, RO, RU, SD, SE, SG, SI, SK, SL, TJ, TM, TR, TT, UA, UG, UZ, VN, YU, ZA, ZW, ARIPO patent (GH, GM, KE, LS, MW, SD, SL, SZ, UG, ZW), Eurasian patent (AM, AZ, BY, KG, KZ, MD, RU, TJ, TM), European patent (AT, BE, CH, CY, DE, DK, ES, FI, FR, GB, GR, IE, IT, LU, MC, NL, PT, SE), OAPI patent (BF, BJ, CF, CG, CI, CM, GA, GN, GW, ML, MR, NE, SN, TD, TG).</p> <p>Published <i>With international search report.</i></p>

(54) Title: BIFURCATED CATHETER ASSEMBLY



(57) Abstract

A bifurcated catheter assembly is provided for treating bifurcated vessels. The bifurcated catheter assembly comprises an elongate main catheter shaft having a stiffer proximal portion, a more flexible distal portion, and a pair of branch catheters attached to the distal portion. An expandable member is located on each of the branch catheters. The balloons are held together to provide a low profile as the device is advanced over the tracking guide wire. Upon reaching the bifurcated vessel, the balloons separated and are advanced over separate guide wires into separate branches of the bifurcated vessel. The bifurcated catheter assembly can be used to dilate a stenosis or deliver and implant a Y-shaped stent in the bifurcation.

FOR THE PURPOSES OF INFORMATION ONLY

Codes used to identify States party to the PCT on the front pages of pamphlets publishing international applications under the PCT.

AL	Albania	ES	Spain	LS	Lesotho	SI	Slovenia
AM	Armenia	FI	Finland	LT	Lithuania	SK	Slovakia
AT	Austria	FR	France	LU	Luxembourg	SN	Senegal
AU	Australia	GA	Gabon	LV	Latvia	SZ	Swaziland
AZ	Azerbaijan	GB	United Kingdom	MC	Monaco	TD	Chad
BA	Bosnia and Herzegovina	GE	Georgia	MD	Republic of Moldova	TG	Togo
BB	Barbados	GH	Ghana	MG	Madagascar	TJ	Tajikistan
BE	Belgium	GN	Guinea	MK	The former Yugoslav Republic of Macedonia	TM	Turkmenistan
BF	Burkina Faso	GR	Greece			TR	Turkey
BG	Bulgaria	HU	Hungary	ML	Mali	TT	Trinidad and Tobago
BJ	Benin	IE	Ireland	MN	Mongolia	UA	Ukraine
BR	Brazil	IL	Israel	MR	Mauritania	UG	Uganda
BY	Belarus	IS	Iceland	MW	Malawi	US	United States of America
CA	Canada	IT	Italy	MX	Mexico	UZ	Uzbekistan
CF	Central African Republic	JP	Japan	NE	Niger	VN	Viet Nam
CG	Congo	KE	Kenya	NL	Netherlands	YU	Yugoslavia
CH	Switzerland	KG	Kyrgyzstan	NO	Norway	ZW	Zimbabwe
CI	Côte d'Ivoire	KP	Democratic People's Republic of Korea	NZ	New Zealand		
CM	Cameroon		Republic of Korea	PL	Poland		
CN	China	KR	Republic of Korea	PT	Portugal		
CU	Cuba	KZ	Kazakstan	RO	Romania		
CZ	Czech Republic	LC	Saint Lucia	RU	Russian Federation		
DE	Germany	LI	Liechtenstein	SD	Sudan		
DK	Denmark	LK	Sri Lanka	SE	Sweden		
EE	Estonia	LR	Liberia	SG	Singapore		

BIFURCATED CATHETER ASSEMBLY

BACKGROUND OF THE INVENTION

The present invention relates in general to balloon catheters employed in the treatment of vascular diseases. More particularly, the present invention relates to a bifurcated catheter assembly which has two dilation balloons in parallel at the distal end of a single catheter shaft. The bifurcated catheter assembly provides an
5 improved means for treating arterial bifurcations.

In a medical procedure known as percutaneous transluminal coronary angioplasty (PTCA), a balloon catheter is used to treat a coronary artery (or other vessel) which has become narrowed or restricted due to the accumulation of plaque along the artery wall. In the PTCA procedure, a balloon catheter is inserted
10 percutaneously and is advanced through the lumen of the coronary artery to the site of a stenosis. The balloon is then inflated to press the plaque against the artery wall thereby dilating the lumen of the artery and establishing adequate blood flow.

After the PTCA procedure has been performed, a stent (which is well known in the art) may be deployed in the treated area to prevent restenosis and maintain a
15 clear pathway for the flow of blood. A balloon catheter with an expandable stent mounted over the balloon is advanced through the lumen until the stent is in the desired location. The balloon is then temporarily inflated thereby expanding and implanting the stent in the vessel. The balloon is then deflated and the balloon catheter assembly is removed from the lumen, leaving the implanted stent in the
20 vessel to support the vessel wall and prevent development of restenosis.

Although most diseased arteries can be successfully treated in this manner using conventional balloon catheters and stents, arteries which are diseased at a bifurcation are difficult to treat with the devices currently available. For example, when a conventional balloon catheter is used to treat one of the vessel passages at a
25 bifurcation during PTCA, the pressure from the expansion of the balloon in the

- 2 -

treated passage can restrict the flow of blood to the untreated passage by pushing the carina over the ostium of the untreated vessel. In addition, the pressure of the balloon in the treated passage may shift the plaque from the treated passage to the untreated passage. If sufficient plaque is shifted to the untreated passage, the ostium
5 of the untreated passage can become so occluded that it becomes difficult or impossible to insert a guide wire and catheter to perform a PTCA in the untreated vessel.

Deploying a stent at a bifurcation is also very challenging because the stent must overlay the entire diseased area of the bifurcation, yet not itself compromise
10 blood flow. Conventional stents are designed to repair areas of blood vessels that are removed from bifurcations and, since a conventional stent generally terminates at right angles to its longitudinal axis, the use of conventional stents in the region of a vessel bifurcation may result in blocking blood flow of a side branch (commonly referred to as "jailing" the side branch) or fail to repair the bifurcation to the fullest
15 extent necessary. To be effective, the stent must overlay the entire circumference of the ostium to a diseased portion and extend to a point within and beyond the diseased portion. Where the stent does not overlay the entire circumference of the ostium to the diseased portion, the stent fails to completely repair the bifurcated vessel.

20 To overcome the problems and limitations associated with the use of conventional stents, a Y-shaped stent has been proposed for the treatment of bifurcations. Such a stent has the advantage of completely repairing the vessel at the bifurcation without obstructing blood flow in other portions of the bifurcation. In addition, such a stent allows access to all portions of the bifurcated vessel should
25 further interventional treatment be necessary. In a situation involving disease in the origin of an angulated aorta-ostial vessel, such a stent would have the advantage of completely repairing the vessel origin without protruding into the aorta or complicating repeat access. The proposed Y-shaped stent provides an improved

- 3 -

device for repairing bifurcations, however, the delivery and deployment of such a stent cannot be easily accomplished with a conventional balloon catheter.

Because a conventional balloon catheter is not adequate for treating an arterial bifurcation, many physicians currently employ a "kissing balloons" technique in which two separate balloon catheters are inserted into a guide catheter and each balloon tracks over a separate guide wire. The guide catheter is advanced to a point proximal of the bifurcation site and two guide wires are then advanced from the distal end of the guide catheter into separate vessel passages. The two balloon catheters then track the guide wires into the respective passages. The balloons are simultaneously inflated using either separate inflation media or from a single source using a manifold which divides the flow. The two catheters are used together for PTCA or stenting so that both vessel passages at a bifurcation site can be treated simultaneously.

Although generally effective, the use of two single balloon catheters to treat arterial bifurcations has significant drawbacks. For example, the presence of two similar catheters exiting the proximal end of the guide catheter makes it difficult for a physician to manage both devices without becoming confused as to which catheter controls which balloon. Furthermore, the presence of two balloon catheters within one guide catheter creates a large device profile thereby limiting the amount of radiopaque dye which can be injected into the vessel to allow the physician to view the bifurcation.

Efforts have been made to develop a balloon catheter which is designed specifically for the treatment of arterial bifurcations. Such efforts have led to the proposal of a Y-shaped balloon disposed at the distal end of a catheter which is inflated in a bifurcation to treat both passages simultaneously. Although a Y-shaped balloon would provide an improvement over the use of two separate balloon catheters, the proposed device may not be practical due to challenges of manufacturing a Y-shaped balloon, attaching it to a catheter shaft, and properly

- 4 -

positioning it at a bifurcated blood vessel. A device of this type is described in the international patent application WO 97/16217 dated October 30, 1995 and entitled Angioplasty Device for Arterial Bifurcation.

Thus, there exists a need for an improved balloon catheter which can be used
5 to effectively treat arterial bifurcations both for PTCA and stent delivery and deployment. It is also desirable that such a balloon catheter be easy to use, inexpensive to manufacture, and constructed from materials which are common in the industry today. The present invention addresses this need.

SUMMARY OF THE INVENTION

10 The present invention provides a bifurcated catheter assembly which can be used to simultaneously dilate stenoses in both the main and the side branch vessels of a bifurcation and also provides a means to quickly and easily deliver and deploy a Y-shaped stent. The invention comprises a single catheter shaft having two individual parallel balloons at the distal end. The parallel balloons track separate
15 guide wires into separate blood vessel passages at a bifurcation and are inflated simultaneously by inflation media from a common source. The present invention is designed primarily for use in coronary arteries, however, it may also be used to treat other vessels such as the renals, abdominal aorta, femoral, and carotid arteries.

The bifurcated catheter assembly of the present invention includes a main
20 catheter body with three lumens in its distal portion. The first lumen is an inflation lumen for pressurized inflation media which is used to inflate and deflate the balloons. The second lumen is a guide wire lumen which contains the tracking guide wire and the third lumen is also a guide wire lumen which contains an integrated guide wire.

25 Two parallel catheter branches are connected to the distal end of the main catheter body. Each of the parallel catheter branches has two lumens. One lumen is

- 5 -

an inflation lumen which communicates with the inflation lumen in the main catheter body and the other lumen is a guide wire lumen in communication with one of the guide wire lumens in the main catheter body. An expandable member such as a balloon is located on the periphery of each catheter branch which is in
5 communication with the inflation lumen in each catheter branch. An inflation notch on the side of each catheter branch allows pressurized inflation media to enter and exit the balloons. The guide wire lumen in each catheter branch extends all the way to the distal end allowing the guide wires to exit distally from the respective branches.

10 The tracking guide wire is advanced through the main vessel and the integrated guide wire is advanced through the ostium and into the side branch vessel at the bifurcation. With one guide wire advanced into each passage of the bifurcation, the bifurcated catheter assembly is advanced so that the first balloon tracks the tracking guide wire into the main vessel passage and the second balloon
15 tracks the integrated guide wire into the side-branch vessel passage.

The bifurcated catheter assembly can be used at an arterial bifurcation both for PTCA and for stent delivery and implanting. Other features and advantages of the present invention will become apparent from the following detailed description, taken in conjunction with the accompanying drawings, which illustrate, by way of
20 example, the features of the invention.

BRIEF DESCRIPTION OF THE DRAWINGS

FIGURE 1 is a sectional view of a diseased arterial bifurcation;

FIG. 2 is a sectional view of an arterial bifurcation showing a prior art single balloon catheter used to dilate the main vessel.

- 6 -

FIG. 3 is an sectional view of an arterial bifurcation showing two prior art balloon catheters used to simultaneously dilate both the main and side branch vessels.

FIG. 4 is an sectional view of an arterial bifurcation showing a prior art Y-shaped balloon used to dilate both the main and side branch vessels.

FIG. 5 is a side elevational view of a bifurcated dilation catheter embodying the present invention.

FIG. 6 is a cross-sectional view in enlarged scale taken along the line 6-6 in FIG. 5 of the proximal portion of the main catheter body.

FIG. 7 is a cross-sectional view in enlarged scale taken along the line 7-7 in FIG. 5 of the distal portion of the main catheter body.

FIG. 8 is a cross-sectional view in enlarged scale taken along the line 8-8 in FIG. 5 of the proximal portion of one of the catheter branches.

FIG. 9 is a cross-sectional view in enlarged scale taken along the line 9-9 in FIG. 5 of the distal portion of one of the catheter branches.

FIG. 10 is a sectional view of an arterial bifurcation showing both balloons dilated during PTCA.

FIG. 11 is a sectional view of an arterial bifurcation showing the invention deploying a stent.

- 7 -

FIG. 12 is an elevational view of the bifurcated catheter assembly showing the catheter branches coupled together.

DETAILED DESCRIPTION OF THE PREFERRED EMBODIMENTS

The present invention includes an assembly and method for treating
5 bifurcations in the coronary arteries, veins, arteries and other vessels in the body. As shown in FIG. 1, an arterial bifurcation is a site within the vasculature of a body where an artery divides into two vessel passages. FIG. 1 also illustrates how plaque can build up on the artery walls creating a narrowing known as a stenosis. The stenosis can be dilated using a balloon catheter to compress the plaque against the
10 vessel wall in a procedure known as PTCA. After the PTCA procedure, a stent is deployed in the vessel to reduce the likelihood of the development of restenosis.

Prior art techniques for treating arterial bifurcations have proved less than satisfactory. For example, FIGS. 2-4 depict prior art techniques for treating arterial bifurcations which include using a single balloon, two single balloons and a Y-
15 shaped balloon. Referring to FIG. 2, a single balloon catheter is inserted into one branch of a bifurcation and is inflated to dilate the stenosis. Using a single balloon catheter to treat an arterial bifurcation requires dilating each vessel passage of the bifurcation individually. Using this approach, the dilation of the treated passage may push against the wall of the untreated passage thereby impeding the blood flow
20 to the untreated branch and also may shift plaque from the treated passage to the untreated passage. Therefore, this technique is inadequate and often produces undesirable results which can harm the patient.

Many physicians attempt to treat a bifurcation by employing a "kissing balloon" technique. Referring to FIG. 3, this prior art device and method uses two
25 separate balloon catheters which are both inserted into a guide catheter and track separate guide wires. One balloon is advanced into each of the vessel passages at

- 8 -

the bifurcation site and the balloons are simultaneously inflated to dilate a stenosis or to deliver and deploy two separate stents to the bifurcation site after the vessels have been dilated. In practice, however, the use of two separate single balloon catheters is cumbersome and it can be difficult for a physician to manage both
5 devices. In addition, the flow of contrast through the guide catheter is restricted by the presence of two catheter shafts within the guide catheter lumen thereby making it difficult for the physician to view the area being treated.

As illustrated in FIG. 4, another prior art device includes a single catheter with a Y-shaped balloon at the distal end and has been proposed as an improved
10 means for treating arterial bifurcations. The prior art discloses a Y-shaped balloon being advanced through the lumen of a vessel and inflated at a bifurcation to dilate both passages simultaneously or to implant a Y-shaped stent. Although the Y-shaped balloon would provide an improvement over the kissing balloons technique, the practicality of the proposed Y-shaped balloon is doubtful because it presents
15 manufacturing challenges, problems associated with positioning (e.g. wire wrapping) and deployment at the bifurcation, and higher profiles.

All of the prior art methods for treating an arterial bifurcation depicted in FIGS. 2-4 have various drawbacks which have been solved by the present invention.

Referring to FIGS. 5-10 and 12, the bifurcated catheter assembly of the
20 present invention provides two separate balloons in parallel which can be advanced into separate passages of an arterial bifurcation and inflated simultaneously to dilate stenoses or to deploy a stent. The bifurcated catheter assembly 10 includes, generally, a main catheter body 11 with a proximal portion 12 having a first inflation lumen 14 and a first guide wire lumen 16 extending therethrough. The
25 proximal portion of the main catheter body preferably is a stainless steel tube surrounded by a polymer jacket (not shown) which can be formed of various materials to increase lubricity including polyethylene, nylon, polyethyl ether ketone,

- 9 -

and copolyester-elastomer. An inflation hub 21 is located at the proximal end of the proximal portion of the main catheter body for attaching an inflation device.

In the preferred embodiment, the bifurcated catheter assembly is of the rapid exchange type, which is known in the art. Referring to FIGS. 5 and 6, a first guide wire lumen 16 includes a first exit port 18 which is at the proximal end of the catheter assembly 10. An integrated guide wire 15 slidably extends from outside the first exit port 18 and into and through the first guide wire lumen 16. As depicted in FIG. 7, a second guide wire lumen 17 is of the rapid exchange type and is configured to slidably receive a tracking guide wire 19. The second guide wire lumen exits the catheter body 11 at a second exit port 20.

Optionally, a slit 13 could be provided in the catheter body 22 between the guide wire exit port 20 and a location just proximal of the balloon 42. This would allow the catheter body to be "peeled away" from the tracking guide wire 19 to allow for more convenient catheter exchange.

The proximal portion 12 of the main catheter body 11 is connected to the distal portion 22 of the main catheter body 11. The distal portion of the main catheter body preferably is formed from a polymer material to provide increased flexibility in the distal portion of the catheter. The distal portion of the main catheter body includes an extension of the first inflation lumen 14 for carrying inflation media, the first guide wire lumen 16 containing the integrated guide wire 15 and the second guide wire lumen 17 containing the tracking guide wire 19. The connection 30 between the proximal portion and the distal portion of the main catheter body allows for the continuous flow of inflation media between the proximal and distal portions with no leaks.

A cross-section through the catheter branch 32 is illustrated in FIG. 8. The catheter branch 34 has a similar cross-sectional configuration.

The distal portion 22 of the main catheter body 11 is connected to the first and second parallel catheter branches 32 and 34, respectively. The connection 36

- 10 -

between the distal portion of the main catheter body and each of the parallel catheter branches allows for continuous flow of inflation media from the first inflation lumen in the distal shaft to second and third inflation lumens 37, 38 in each of the catheter branches. The parallel catheter branches 32,34 respectively contain second and
5 third inflation lumens 37,38 for communicating inflation media and first and second guide wire lumens 16,17 for carrying the integrated guide wire 15 and the tracking guide wire 19. The first and second catheter branches have distal tips 46,48, respectively, through which the guide wires exit the guide wire lumens. The tracking guide wire 19 exits from the distal tip 46 of the first catheter branch 32 and
10 the integrated guide wire 15 exits from the distal tip 48 of the second catheter branch 34. As shown in FIG 12, attached to the side of the distal end of the second catheter branch 34 is a coupling device 54 in the form of a short tube. During advancement of the catheter assembly, the tracking guide wire 19 exits the first catheter branch 32 and is threaded through the coupling device in the second
15 catheter branch 34 to hold the two catheter branches together.

Mounted on the catheter branches 32, 34, respectively are expandable members preferably in the form of balloons 42,44. The balloons can be formed of many different materials including polyethylene, polyolefin copolymer, polyethylene terephthalate, nylon, and Pebax. The inflation hub 21 receives
20 pressurized inflation fluid and supplies the inflation fluid to the inflation lumens 14, 37 and 38. Each catheter branch includes an inflation notch (notches 50 and 52 respectively), which notches allow inflation media to exit the catheter and to inflate the expandable members.

In the preferred embodiment, the overall catheter is about 135 cm to 150 cm
25 long, and the main catheter body between the inflation hub 21 and the connection 30 is about 125 cm in length. The proximal portion of the main catheter body preferably has a diameter of about 0.75 mm and the distal portion of the main catheter body between the connection between the proximal portion and the distal

- 11 -

portion of the main catheter body and the connection 36 between the distal portion of the main catheter body and each of the parallel catheter branches has a diameter of about 1.5 mm. The first catheter branch 32 preferably is about 10 cm in length with a diameter of about 1 mm, and the second catheter branch 34 is about 12 cm in
5 length with a diameter of about 1 mm. Typically, the expandable members are balloons which preferably are from about 1.5 mm to about 4.5 mm in diameter when expanded and are about 20 mm in length, for treating coronary arteries. The foregoing dimensions will vary greatly depending upon the particular application and body lumen being treated.

10 The assembly of the present invention is configured for low profile delivery without compromising pushability and trackability over both guide wires. The proximal portion 12 of the main catheter shaft 11 may be made by necking the jacket material over the stainless steel tubing. The jacketed tube then is connected to the distal portion 22 of the main catheter shaft. Mandrels are inserted into the
15 guide wire lumens 16, 17 and the inflation lumens to prevent the lumens from collapsing during the fusing phase when heat is applied and the proximal portion is heat fused to the distal portion of the main catheter shaft. After the junction 30 has cooled, the mandrels are removed, leaving continuous and leak-proof inflation lumens which extend all the way through the catheter assembly shaft.

20 Each of the parallel catheter branches 32 and 34 is constructed as is standard in the art of catheter assembly. The balloons 42 and 44 are attached to each of the branches using a known technique such as heat seal, adhesive, laser weld, or solvent bond, alternatively, or the balloons are formed as one piece from the same tubing material as catheter branches. The two parallel catheter branches then are connected
25 to the distal portion of the main catheter body, also through the use of heat, to complete the assembly. The method of assembly of the catheter may vary depending upon available materials and manufacturer preferences.

- 12 -

In operation, the tracking guide wire 19 is inserted percutaneously into, for instance, the femoral artery, and is maneuvered to the bifurcation site such that the distal end of the tracking guide wire is in the main vessel passage distal to the bifurcation. The proximal end of the tracking wire 19 is inserted into the short tube
5 of the coupling device 54, passing the tracking wire 19 through the tips of both branches together. The proximal end of the tracking wire 19 then is inserted into the distal tip 46 of the catheter branch 32. This allows for smooth, uninterrupted movement of the catheter to the target site. The bifurcated catheter assembly 10 then is advanced over the tracking guide wire such that the balloons 42 and 44 are in
10 the main vessel passage just distal to the bifurcation. Because this invention is a rapid-exchange type of catheter, a portion of the tracking guide wire 19 is located external to the catheter and therefore there is very little frictional drag during advancement of the assembly. When the balloons have been advanced distally beyond the bifurcation, the tracking guide wire 19 is withdrawn proximally until its
15 distal end pulls out of coupling device 54, thereby decoupling the balloons from each other. Then tracking wire 19 then is advanced back through the tip 46 into the main vessel passage. The bifurcated catheter assembly then is withdrawn proximally along the tracking guide wire so that the balloons are proximal to the bifurcation. With the tracking guide wire still in the main vessel passage, the
20 integrated guide wire, which has been contained within the second guide wire lumen 17, is advanced from the distal tip of the other catheter branch 34 into the side-branch vessel. At this point, there is one guide wire exiting the distal tip of each catheter branch and entering a separate passage of the bifurcation whereby the tracking guide wire is in the main vessel passage and the integrated guide wire is in
25 the side branch vessel passage. The catheter assembly then is advanced over the guide wires whereby each balloon tracks a guide wire into a separate passage of the bifurcation until the balloons are positioned at the stenosed areas.

- 13 -

An inflation syringe (or pump) located outside the patient's body is attached to the inflation hub 21 and supplies pressurized inflation media through the inflation lumens and into the balloons 42 and 44. With one balloon in each passage, the balloons simultaneously can be inflated to dilate a stenosis during a PTCA procedure as illustrated in FIG. 10. Because both passages of the bifurcation are treated simultaneously, neither of the passages is pinched off or damaged by the procedure. In addition, all of the plaque in the bifurcation is compressed at the same time and therefore there is no shifting of plaque from one passage to the other. After the stenosed areas have been dilated, the balloons are deflated to their minimum dimensions so that they can be easily withdrawn from the vessels.

In the preferred embodiment shown in the figures, the device could be removed together with the integrated wire 17, while the tracking wire 19 remains in the main vessel passage. This is facilitated by the rapid-exchange configuration of the device, wherein the tracking wire 19 exits the catheter body 22 through the exit port 20, which exit port is located about 25 cm proximal from the distal end of the balloon.

The slitted configuration mentioned above would further facilitate a rapid-exchange procedure. Optionally, the lumen 16 through which the integrated wire 17 passes, could be provided with a rapid-exchange guide wire exit port on the catheter body. This would allow maintaining of each wire in position in their respective vessels during the catheter exchange. As a further option, the lumen 16 also could be slitted to further facilitate rapid exchange. In this case, a second guide wire exit port would be provided distal of the proximal hub.

Another advantage of the invention is the ability to deliver and implant a Y-shaped stent to the bifurcation as shown in FIG. 11. In this procedure, the bifurcated catheter assembly 10 has a Y-shaped stent 60 mounted onto the balloons. The balloons 42 and 44 are held together during delivery to provide a low profile, allowing room for radiopaque dye to be injected into the bloodstream during the

- 14 -

procedure. The tracking guide wire is advanced into the main vessel to a point distal of the bifurcation. The bifurcated catheter assembly then is advanced over the tracking guide wire so that the stent is distal to the bifurcation. The tracking guide wire then is withdrawn proximally, thereby decoupling the balloons. The catheter assembly then is withdrawn proximally until it is proximal to the bifurcation with the tracking guide wire remaining in the main vessel. The integrated guide wire then is advanced out of the branch catheter 34 and into the side-branch vessel. The catheter assembly is advanced over both guide wires until the balloons and stent are anchored in the bifurcation. The balloons are inflated and the stent expanded and
5
10 implanted in the bifurcation.

From the foregoing, it will be appreciated that the bifurcated catheter assembly of the invention allows both passages of a diseased bifurcation to be dilated simultaneously during a PTCA procedure, thereby avoiding any possible damage to the vessels and avoiding the transfer of plaque from one passage to the
15 other. The bifurcated catheter assembly also facilitates the delivery and deployment of a Y-shaped stent which is designed specifically for use in a bifurcation. The invention is made of materials commonly used in the industry today and is simple to use and easy to manufacture.

While a particular form of the invention has been illustrated and described, it
20 will be apparent that various modifications can be made without departing from the spirit and scope of the invention.

- 15 -

WHAT IS CLAIMED IS:

1. A bifurcated catheter assembly for treating bifurcated vessels,
comprising:

an elongate main catheter body having a proximal portion and a distal
portion, a first inflation lumen, a first guide wire lumen, and a second guide wire
5 lumen;

a first catheter branch connected to the distal portion of the main
catheter body and having a second inflation lumen in fluid communication with the
first inflation lumen in the main catheter body and the first guide wire lumen
extending therethrough and in communication with the first guide wire lumen in the
10 main catheter body;

a second catheter branch connected to the distal portion of the main
catheter body and having a third inflation lumen in fluid communication with the
first inflation lumen and the second guide wire lumen extending therethrough and in
communication with the second guide wire lumen in the main catheter body;

15 a first expandable member associated with the first catheter branch
and in fluid communication with the second inflation lumen;

a second expandable member associated with the second catheter
branch in fluid communication with the third inflation lumen;

20 whereby the first expandable member and the second expandable
member are positioned across a stenosis in a main vessel and in a side branch vessel
respectively so that the expandable members can be inflated simultaneously to dilate
the stenosis and to restore patency to the main vessel and the side branch vessel.

2. The bifurcated catheter assembly as set forth in claim 1, wherein
the first and second expandable members are balloons.

- 16 -

3. The bifurcated catheter assembly as set forth in claim 1, wherein the first, second and third inflation lumens communicate pressurized fluid to the first and second expandable members.

4. The bifurcated catheter assembly as set forth in claim 1, wherein the main catheter body includes a coupler mounted on distal end of the first catheter branch for coupling to a distal end of the second catheter branch.

5. The bifurcated catheter assembly as set forth in claim 1, wherein the bifurcated catheter assembly includes an integrated guide wire slidably received in the first guide wire lumen and a tracking guide wire slidably received in the second guide wire lumen.

6. The bifurcated catheter assembly as set forth in claim 1, wherein the first and second branches are non-movably connected to the main catheter body.

1/5

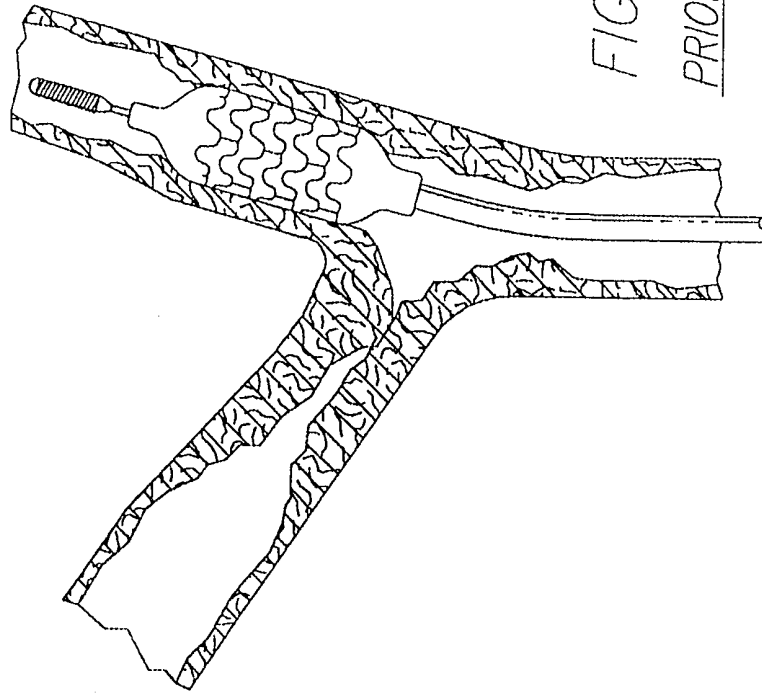

FIG. 2
PRIOR ART

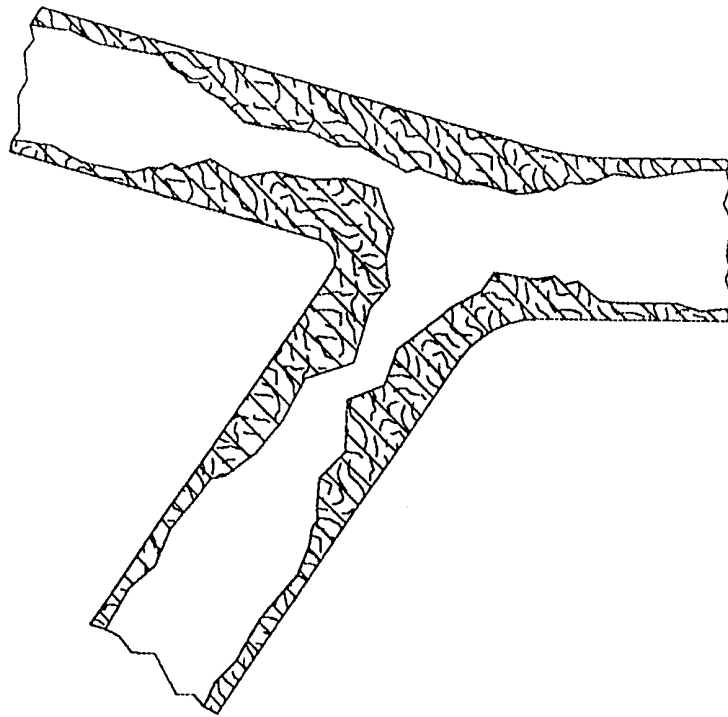

FIG. 1

FIG. 4

PRIOR ART

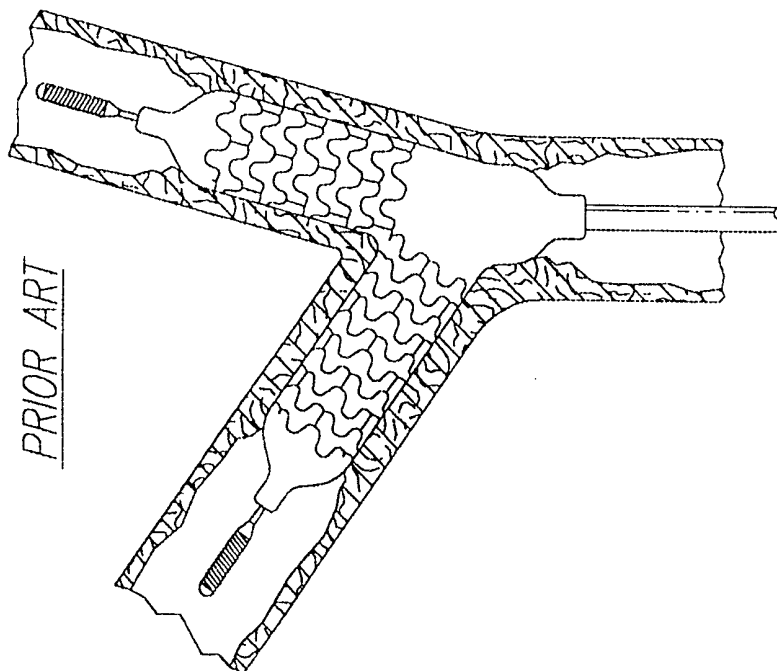
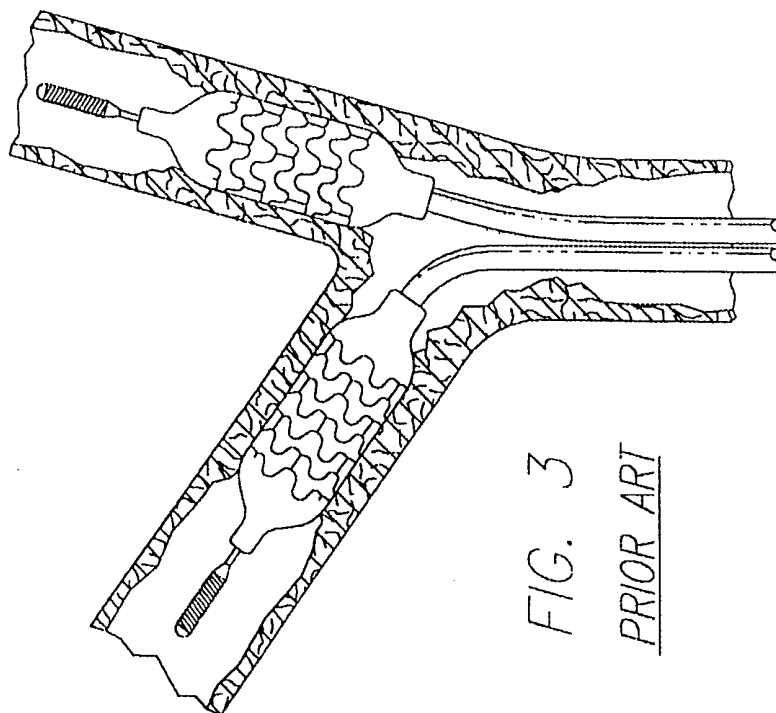
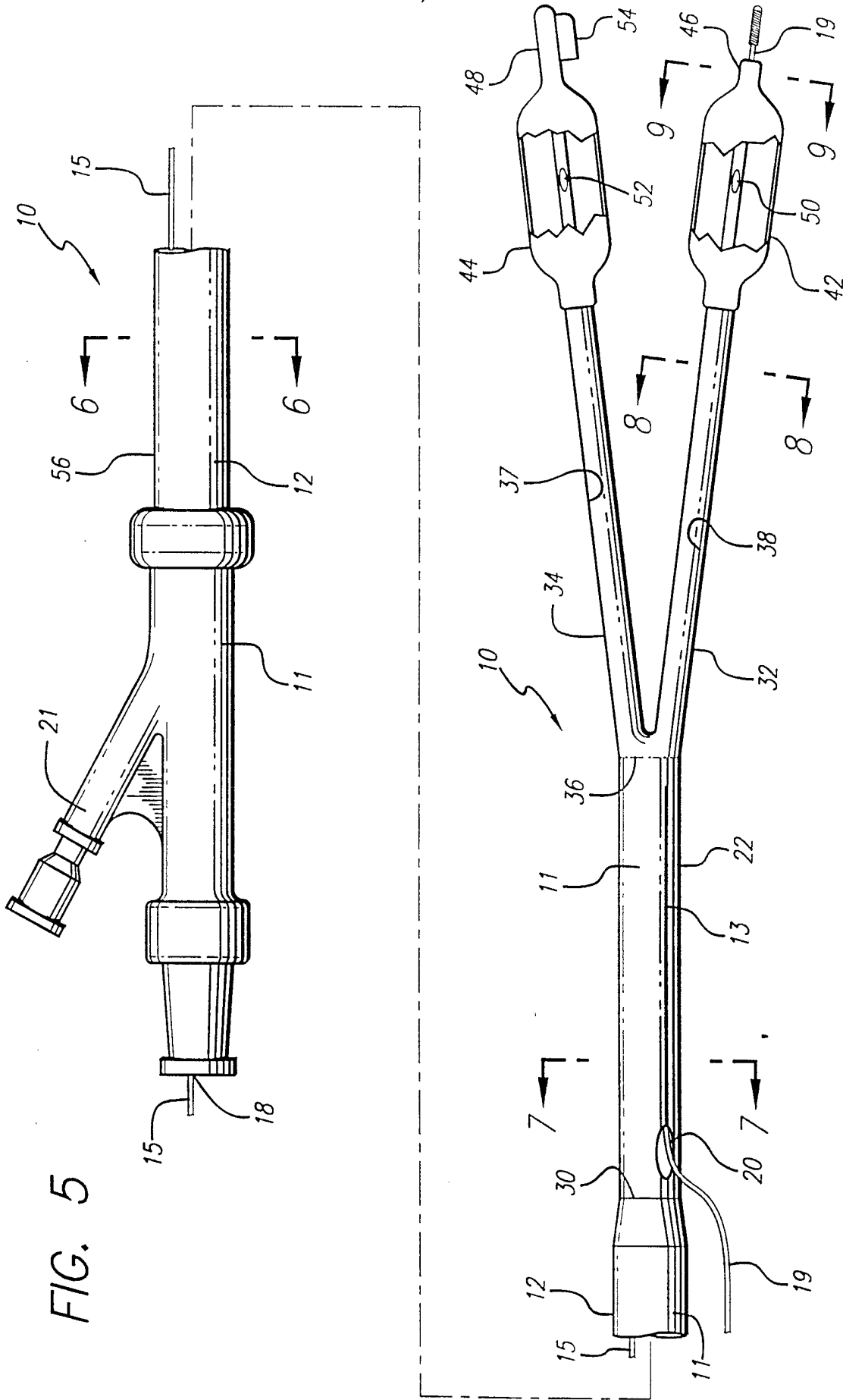

FIG. 3

PRIOR ART





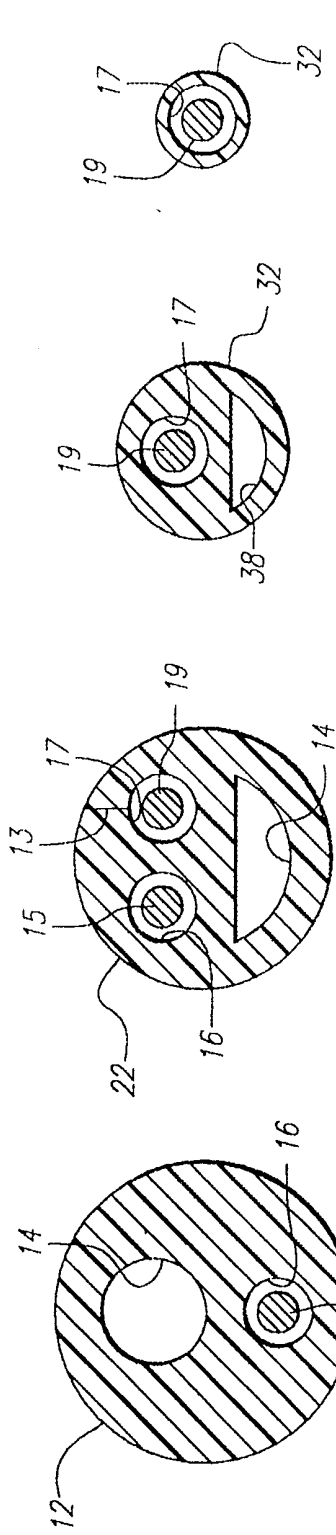

FIG. 9

FIG. 8

FIG. 7

FIG. 6

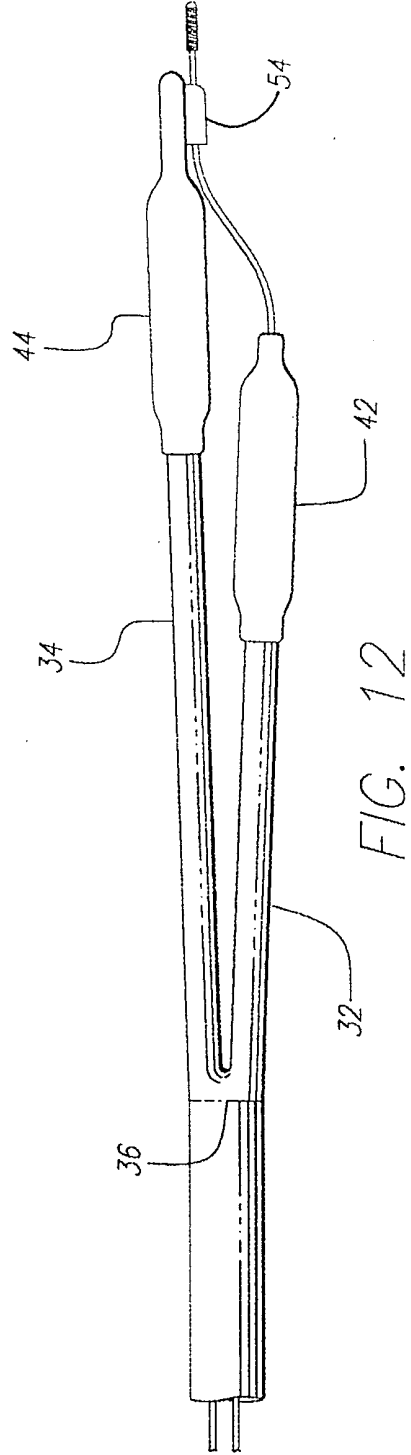

FIG. 12

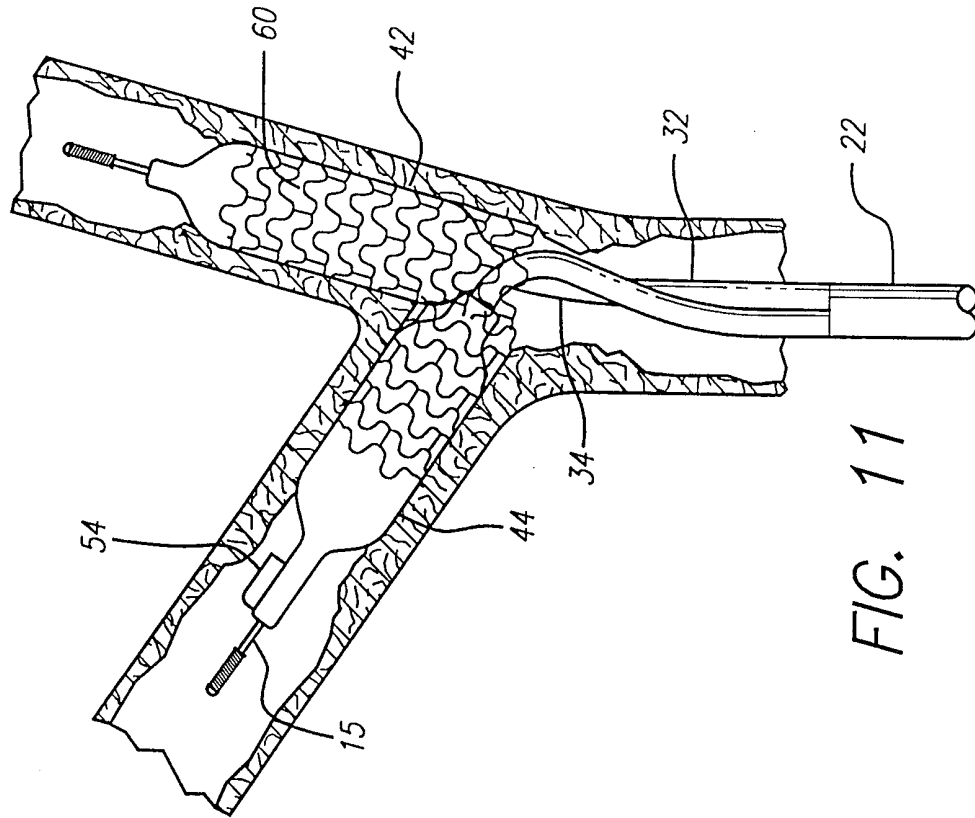

FIG. 11

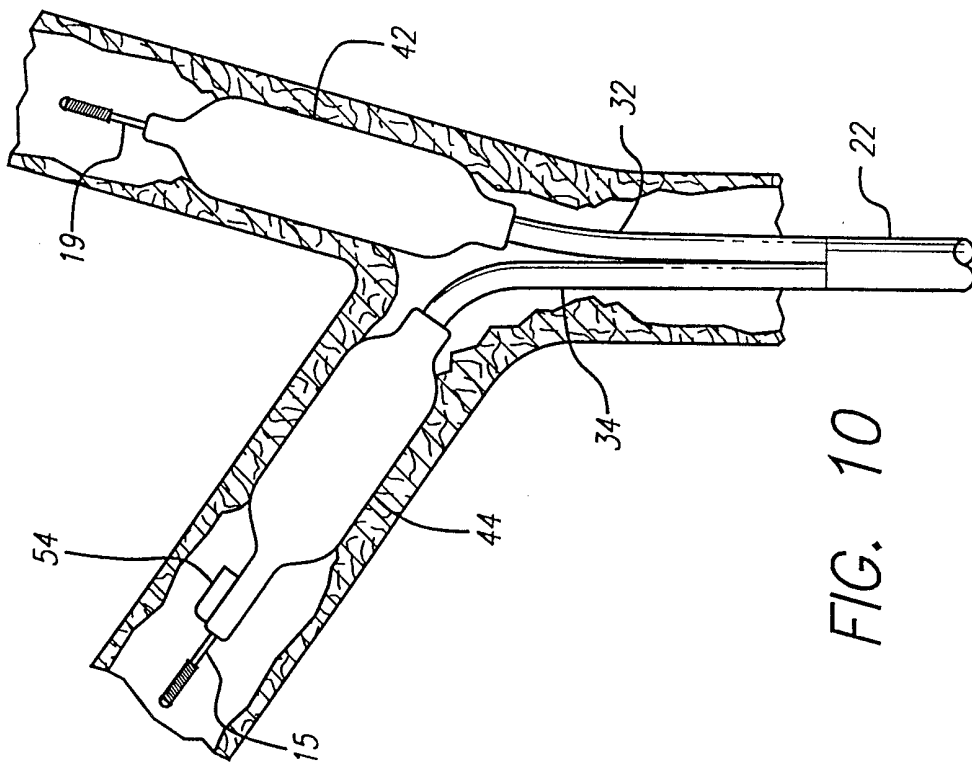

FIG. 10

INTERNATIONAL SEARCH REPORT

Intern. Application No
PCT/US 99/19127

A. CLASSIFICATION OF SUBJECT MATTER IPC 7 A61F2/06		
According to International Patent Classification (IPC) or to both national classification and IPC		
B. FIELDS SEARCHED Minimum documentation searched (classification system followed by classification symbols) IPC 7 A61F		
Documentation searched other than minimum documentation to the extent that such documents are included in the fields searched		
Electronic data base consulted during the international search (name of data base and, where practical, search terms used)		
C. DOCUMENTS CONSIDERED TO BE RELEVANT		
Category °	Citation of document, with indication, where appropriate, of the relevant passages	Relevant to claim No.
A	WO 96 34580 A (DIBIE) 7 November 1996 (1996-11-07) page 8, paragraph 4 - paragraph 5; figures 11-13 ----	1
A	US 5 755 771 A (PENN) 26 May 1998 (1998-05-26) column 7, paragraph 5; figure 6 ----	1
A	US 5 669 924 A (SHAKNOVICH) 23 September 1997 (1997-09-23) column 9, paragraph 4; figure 14 ----	1
A	FR 2 740 346 A (DEBIOTECH) 30 April 1997 (1997-04-30) cited in the application figure 1 ----	1
-/--		
<input checked="" type="checkbox"/> Further documents are listed in the continuation of box C. <input checked="" type="checkbox"/> Patent family members are listed in annex.		
° Special categories of cited documents :		
"A" document defining the general state of the art which is not considered to be of particular relevance "E" earlier document but published on or after the international filing date "L" document which may throw doubts on priority claim(s) or which is cited to establish the publication date of another citation or other special reason (as specified) "O" document referring to an oral disclosure, use, exhibition or other means "P" document published prior to the international filing date but later than the priority date claimed	"T" later document published after the international filing date or priority date and not in conflict with the application but cited to understand the principle or theory underlying the invention "X" document of particular relevance; the claimed invention cannot be considered novel or cannot be considered to involve an inventive step when the document is taken alone "Y" document of particular relevance; the claimed invention cannot be considered to involve an inventive step when the document is combined with one or more other such documents, such combination being obvious to a person skilled in the art. "&" document member of the same patent family	
Date of the actual completion of the international search <div style="text-align: center; font-weight: bold;">18 November 1999</div>	Date of mailing of the international search report <div style="text-align: center; font-weight: bold;">06/12/1999</div>	
Name and mailing address of the ISA European Patent Office, P.B. 5818 Patentlaan 2 NL - 2280 HV Rijswijk Tel. (+31-70) 340-2040, Tx. 31 651 epo nl, Fax: (+31-70) 340-3016	Authorized officer <div style="text-align: center; font-weight: bold;">Barton, S</div>	

INTERNATIONAL SEARCH REPORT

International Application No

PCT/US 99/19127

C.(Continuation) DOCUMENTS CONSIDERED TO BE RELEVANT

Category *	Citation of document, with indication, where appropriate, of the relevant passages	Relevant to claim No.
A	WO 97 45073 A (BARD GALWAY) 4 December 1997 (1997-12-04) page 16, paragraph 2 -page 17, paragraph 1; figure 1 -----	1
P,X	EP 0 897 700 A (ADVANCED CARDIOVASCULAR) 24 February 1999 (1999-02-24) figure 27B -----	1-6

INTERNATIONAL SEARCH REPORT

Information on patent family members

International Application No

PCT/US 99/19127

Patent document cited in search report	Publication date	Patent family member(s)	Publication date
WO 9634580 A	07-11-1996	FR 2733682 A	08-11-1996
		AU 709513 B	02-09-1999
		AU 5345096 A	21-11-1996
		CA 2220141 A	07-11-1996
		JP 11504824 T	11-05-1999
US 5755771 A	26-05-1998	CA 2134997 A	04-05-1996
		AT 166783 T	15-06-1998
		AU 3739795 A	31-05-1996
		WO 9614028 A	17-05-1996
		CZ 9701329 A	17-12-1997
		DE 69502817 D	09-07-1998
		DE 69502817 T	25-02-1999
		EP 0751752 A	08-01-1997
		EP 0847734 A	17-06-1998
		ES 2119487 T	01-10-1998
		GR 3027774 T	30-11-1998
		HK 1009322 A	28-05-1999
		JP 10508234 T	18-08-1998
		US 5906640 A	25-05-1999
US 5669924 A	23-09-1997	AU 7472796 A	15-05-1997
		WO 9715346 A	01-05-1997
FR 2740346 A	30-04-1997	AU 7499296 A	22-05-1997
		WO 9716217 A	09-05-1997
WO 9745073 A	04-12-1997	IT B0960294 A	01-12-1997
		IT B0970228 A	16-10-1998
		AU 2785597 A	05-01-1998
		BR 9702255 A	17-02-1999
		EP 0844853 A	03-06-1998
		JP 11509767 T	31-08-1999
EP 897700 A	24-02-1999	JP 11057019 A	02-03-1999