

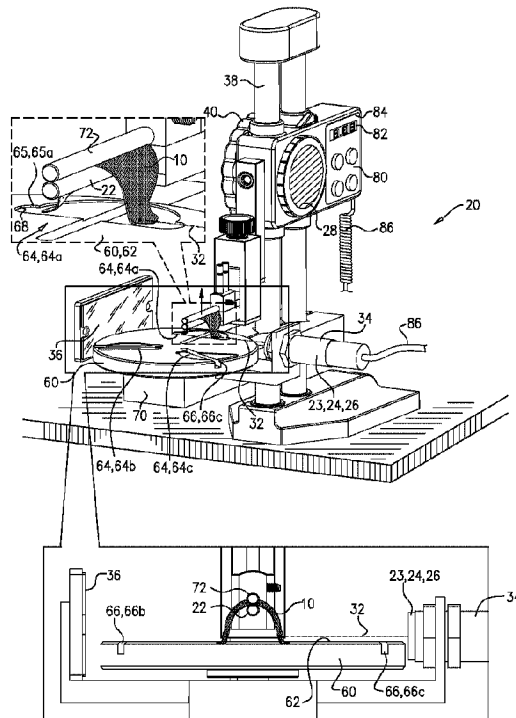

(86) Date de dépôt PCT/PCT Filing Date: 2018/01/08
 (87) Date publication PCT/PCT Publication Date: 2019/04/25
 (45) Date de délivrance/Issue Date: 2024/05/28
 (85) Entrée phase nationale/National Entry: 2020/03/31
 (86) N° demande PCT/PCT Application No.: IL 2018/050024
 (87) N° publication PCT/PCT Publication No.: 2019/077595
 (30) Priorité/Priority: 2017/10/19 (US15/788,407)

(51) Cl.Int./Int.Cl. *A61F 2/24* (2006.01)
 (72) Inventeurs/Inventors:
 HARARI, BOAZ, IL;
 HARITON, ILIA, IL
 (73) Propriétaire/Owner:
 CARDIOVALVE LTD., IL
 (74) Agent: VANTEK INTELLECTUAL PROPERTY LLP

(54) Titre : TECHNIQUES A UTILISER POUR FEUILLETS DE VALVULE PROTHETIQUE
 (54) Title: TECHNIQUES FOR USE WITH PROSTHETIC VALVE LEAFLETS



(57) **Abrégé/Abstract:**

Apparatus (20) for testing a prosthetic leaflet (10) includes a bar (22); a light source (24); a detector (26); an actuator (40); a gauge (28); a display (82); and circuitry (84). The leaflet is draped over the bar. The light source emits a beam of light (32). The detector detects the beam, and generates a detection-signal indicative of detection of the beam. Actuation of the actuator moves the bar with respect to the beam. The gauge measures an elevation of the bar above the beam, the elevation changing with the moving of the bar by the actuator. The circuitry is configured: (i) to receive the measured elevation from the gauge, (ii) to receive the detection-signal from the detector, and (iii) in response to the detection-signal, to drive the display to display the elevation that was measured when the detection-signal was received by the circuitry.

(12) INTERNATIONAL APPLICATION PUBLISHED UNDER THE PATENT COOPERATION TREATY (PCT)

CORRECTED VERSION

(19) World Intellectual Property
Organization

International Bureau

(43) International Publication Date
25 April 2019 (25.04.2019)(10) International Publication Number
WO 2019/077595 A9

- (51) **International Patent Classification:**
A61F 2/24 (2006.01)
- (21) **International Application Number:**
PCT/IL2018/050024
- (22) **International Filing Date:**
08 January 2018 (08.01.2018)
- (25) **Filing Language:** English
- (26) **Publication Language:** English
- (30) **Priority Data:**
15/788,407 19 October 2017 (19.10.2017) US
- (63) **Related by continuation (CON) or continuation-in-part (CIP) to earlier application:**
US 15/788,407 (CON)
Filed on 19 October 2017 (19.10.2017)
- (71) **Applicant: CARDIOVALVE LTD.** [IL/IL]; 1 Yahadut Canada Street, 6037501 Or Yehuda (IL).
- (72) **Inventors: HARARI, Boaz;** 7/50 Derech Hamelech Street, 55900 Ganey Tikva (IL). **HARITON, Ilia;** 14B Orvani Street, 30900 Zichron Yaakov (IL).
- (74) **Agent: COLB, Sanford T.** et al.; SANFORD T. COLB & CO., 4 Shaar Hagai Street, P.O. Box 2273, 7612201 Rehovot (IL).
- (81) **Designated States** (unless otherwise indicated, for every kind of national protection available): AE, AG, AL, AM, AO, AT, AU, AZ, BA, BB, BG, BH, BN, BR, BW, BY, BZ, CA, CH, CL, CN, CO, CR, CU, CZ, DE, DJ, DK, DM, DO, DZ, EC, EE, EG, ES, FI, GB, GD, GE, GH, GM, GT, HN, HR, HU, ID, IL, IN, IR, IS, JO, JP, KE, KG, KH, KN, KP, KR, KW, KZ, LA, LC, LK, LR, LS, LU, LY, MA, MD, ME, MG, MK, MN, MW, MX, MY, MZ, NA, NG, NI, NO, NZ, OM, PA, PE, PG, PH, PL, PT, QA, RO, RS, RU, RW, SA, SC, SD, SE, SG, SK, SL, SM, ST, SV, SY, TH, TJ, TM, TN, TR, TT, TZ, UA, UG, US, UZ, VC, VN, ZA, ZM, ZW.
- (84) **Designated States** (unless otherwise indicated, for every kind of regional protection available): ARIPO (BW, GH, GM, KE, LR, LS, MW, MZ, NA, RW, SD, SL, ST, SZ, TZ, UG, ZM, ZW), Eurasian (AM, AZ, BY, KG, KZ, RU, TJ, TM), European (AL, AT, BE, BG, CH, CY, CZ, DE, DK, EE, ES, FI, FR, GB, GR, HR, HU, IE, IS, IT, LT, LU, LV, MC, MK, MT, NL, NO, PL, PT, RO, RS, SE, SI, SK, SM,

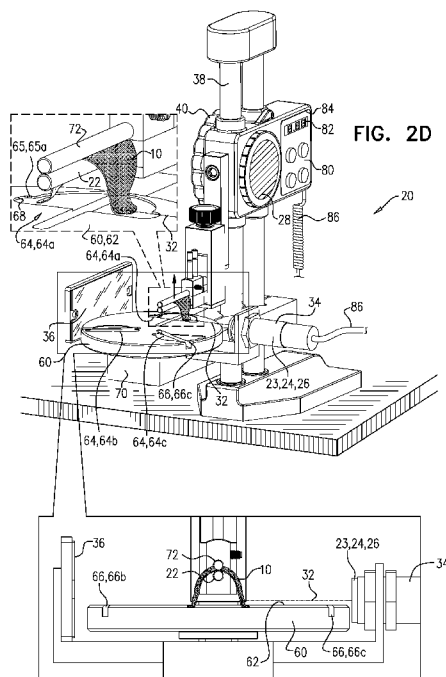
(54) **Title:** TECHNIQUES FOR USE WITH PROSTHETIC VALVE LEAFLETS

(57) **Abstract:** Apparatus (20) for testing a prosthetic leaflet (10) includes a bar (22); a light source (24); a detector (26); an actuator (40); a gauge (28); a display (82); and circuitry (84). The leaflet is draped over the bar. The light source emits a beam of light (32). The detector detects the beam, and generates a detection-signal indicative of detection of the beam. Actuation of the actuator moves the bar with respect to the beam. The gauge measures an elevation of the bar above the beam, the elevation changing with the moving of the bar by the actuator. The circuitry is configured: (i) to receive the measured elevation from the gauge, (ii) to receive the detection-signal from the detector, and (iii) in response to the detection-signal, to drive the display to display the elevation that was measured when the detection-signal was received by the circuitry.

WO 2019/077595 A9

[Continued on next page]

WO 2019/077595 A9 

TR), OAPI (BF, BJ, CF, CG, CI, CM, GA, GN, GQ, GW,
KM, ML, MR, NE, SN, TD, TG).

Published:

— *with international search report (Art. 21(3))*

(48) Date of publication of this corrected version:

15 August 2019 (15.08.2019)

(15) Information about Correction:

see Notice of 15 August 2019 (15.08.2019)

TECHNIQUES FOR USE WITH PROSTHETIC VALVE LEAFLETS

CROSS-REFERENCES TO RELATED APPLICATIONS

The present application claims priority from, and is a Continuation of, US Patent Application 15/788,407 to Harari et al., filed October 19, 2017, and entitled "Techniques for use with prosthetic valve leaflets."

FIELD OF THE INVENTION

Some applications of the present invention relate in general to prosthetic heart valves. More specifically, some applications of the present invention relate to techniques for testing the flexibility of prosthetic leaflets to be used in prosthetic heart valves.

10

BACKGROUND

Prosthetic heart valves may be constructed of a frame to which prosthetic leaflets are attached, the leaflets providing check-valve functionality by opening in response to blood flow in a first direction, and closing in response to blood flow in a second direction. In order to inhibit leakage ("regurgitation") of blood between the closed leaflets in the second direction, it is important that the leaflets coapt well against each other.

15

SUMMARY OF THE INVENTION

Techniques are provided for determining one or more flexibility values of a prosthetic valve leaflet by draping the leaflet over a bar in one or more orientations, and measuring how low the leaflet hangs below the bar. This measurement is made by elevating the bar and measuring an elevation of the bar with respect to a reference. For some applications, the bar is positioned such that the leaflet draped over the bar blocks a light beam, and the bar is then elevated until the leaflet no longer blocks the light beam. The flexibility value is determined responsively to the elevation of the bar at which the leaflet no longer blocks the light beam.

20

Prosthetic valves are constructed using prosthetic valve leaflets that have complementary flexibility values.

25

There is therefore provided, in accordance with an application of the present invention, apparatus for testing a prosthetic heart valve leaflet, the apparatus including:

a vertical post, having a longitudinal axis;

a horizontal bar having a bar-axis that lies on a vertical bar-plane, the bar being configured to support the leaflet along the bar-axis such that the leaflet drapes over the bar;

30

a linear actuator, movably coupling the bar to the post, actuation of the actuator moving the bar vertically in the bar-plane;

a light source, configured to emit a beam of light, and oriented to direct the beam through the bar-plane;

- 5 a gauge, configured to measure an elevation of the bar above the beam; and
a detector, configured and positioned to detect the beam, and to generate a detection-signal indicative of detection of the beam.

In an application, the bar extends laterally away from the post.

In an application, the light source is disposed laterally from the post.

- 10 In an application, the light source is oriented to direct the beam horizontally through the bar-plane.

In an application, the coupling, by the actuator, of the bar to the post, is such that the moving of the bar vertically in the bar-plane includes moving the bar vertically through the beam.

- 15 In an application, the light source includes a laser, and the light beam includes a laser beam.

In an application, the apparatus further includes a platform having a surface, the platform coupled to the post such that the bar-plane intersects the platform, the actuation of the actuator moving the bar vertically, in the bar-plane, with respect to the platform.

- 20 In an application, the light source is adjustably coupled to the platform, such that a distance between the beam of light and the surface is adjustable by adjusting a position of the light source with respect to the platform.

In an application, the bar has an initial position with respect to the platform, in which the leaflet is placeable across the bar and in contact with the surface.

- 25 In an application, in the initial position, the bar is disposed below the surface.

- In an application, the platform has a guide that defines a guide-outline that (i) corresponds to a leaflet-outline of the leaflet, and (ii) has a guide-outline position and a guide-outline orientation that indicate, respectively, a leaflet-outline position and a leaflet-outline orientation in which the leaflet is to be placed when the leaflet is placed across the bar and in
30 contact with the surface.

In an application, the platform is coupled to the post such that the bar-plane bisects the guide-outline.

In an application, the platform is coupled to the post such that the bar-plane bisects the guide-outline symmetrically.

5 In an application:
 the platform is a first platform,
 the guide is a first guide,
 the guide-outline is a first guide-outline,
 the apparatus further includes a coupling,
 10 the first platform is removably couplable to the post via the coupling
 when the first platform is coupled to the post via the coupling, the bar-plane bisects the first guide-outline at a first angle,

the apparatus further includes a second platform that has a second guide that defines a second guide-outline that corresponds to the leaflet-outline of the leaflet,

15 the second platform is removably couplable to the post via the coupling, and
 when the second platform is coupled to the post via the coupling, the bar-plane bisects the second guide-outline at a second angle.

In an application:

the guide is a first guide,
 20 the guide-outline is a first guide-outline,
 the platform has a second guide that defines a second guide-outline that corresponds to the leaflet-outline of the leaflet,

the apparatus has a first guide-state in which the bar-plane bisects the first guide-outline,

the apparatus has a second guide-state in which the bar-plane bisects the second guide-
 25 outline, and

the apparatus further includes a coupling via which the platform is movably coupled to the post, such that movement of the platform with respect to the post transitions the apparatus between the first guide-state and the second guide-state.

30 In an application, in the first guide-state, the bar-plane bisects the first guide-outline at a first angle, and in the second guide-state, the bar-plane bisects the second guide-outline at a second angle.

In an application, in the first guide-state, the bar-plane bisects the first guide-outline symmetrically, but in the second guide-state, the bar-plane bisects the second guide-outline asymmetrically.

5 In an application, the coupling is a rotating coupling, and rotation of the platform with respect to the post via the rotating coupling transitions the apparatus between the first guide-state and the second guide-state.

In an application, the platform defines a longitudinal hollow that lies on the bar-plane, and the bar, in its initial position, is disposed in the hollow.

10 In an application, the apparatus further includes a clamping element, movably coupled to the bar, and configured to clamp the leaflet to the bar.

In an application, the clamping element includes a rod, parallel to the bar, and configured to clamp the leaflet against the bar along the bar-axis.

In an application, the apparatus further includes a spring that provides a clamping force to clamping element.

15 There is further provided, in accordance with an application of the present invention, apparatus for testing a prosthetic heart valve leaflet, the apparatus including:

a bar having a bar-axis, the bar being configured to support the leaflet along the bar-axis such that the leaflet drapes over the bar;

a light source, configured to emit a beam of light;

20 a detector, configured to detect the beam, and to generate a detection-signal indicative of detection of the beam;

a linear actuator, movably coupling the bar to the light source, actuation of the actuator moving the bar with respect to the beam;

25 a gauge, configured to measure an elevation of the bar above the beam, the elevation changing with the moving of the bar by the actuator;

a display, and

circuitry, electrically connected to the detector, the gauge, and the display, and configured:

to receive, from the gauge, the measured elevation,

30 to receive the detection-signal from the detector, and

in response to the detection-signal, to drive the display to display the elevation that was measured when the detection-signal was received by the circuitry.

In an application, the linear actuator is configured such that the actuation of the actuator moves the bar through the beam.

5 In an application, the gauge is configured to continuously measure the elevation, and the circuitry is configured to continuously receive the measured elevation.

In an application, the circuitry is configured:

while the detection-signal is not received by the circuitry, to continuously drive the display to display the continuously-measured elevation, and

10 in response to the detection-signal, to maintain, on the display, the elevation that was measured at a time that the detection-signal was received by the circuitry.

There is further provided, in accordance with an application of the present invention, a method for determining a flexibility of a prosthetic heart valve leaflet, the method including:

15 placing the leaflet across a bar, and positioning the bar such that the leaflet drapes over the bar and blocks a beam of light emitted by a light source;

while the leaflet remains draped over the bar, elevating the bar at least until the leaflet stops blocking the beam;

identifying an elevation, of the bar from the beam, at which the leaflet stopped blocking the beam; and

20 responsively to the identified elevation, assigning a flexibility value to the leaflet.

In an application, elevating the bar at least until the leaflet stops blocking the beam includes moving the bar through the beam.

In an application, the bar is movably coupled to a post via a linear actuator, and elevating the bar includes actuating the linear actuator.

25 In an application, the light source is a laser, and the beam of light is a laser beam, and: positioning the bar such that the leaflet blocks the beam of light includes positioning the bar such that the leaflet blocks the laser beam; and

elevating the bar at least until the leaflet stops blocking the beam includes elevating the bar at least until the leaflet stops blocking the laser beam.

30 In an application, the method further includes clamping the leaflet to the bar.

In an application, determining the flexibility of the leaflet includes determining the flexibility of a first leaflet, and the method further includes:

determining a flexibility of a second prosthetic heart valve leaflet;

5 identifying that the flexibility of the first leaflet and the flexibility of the second leaflet are within a threshold flexibility difference of each other; and

in response to the identifying, assembling a prosthetic heart valve by attaching the first leaflet and the second leaflet to a frame.

In an application:

10 positioning the bar such that the leaflet blocks the beam includes positioning the bar such that the leaflet blocks the beam from reaching a detector configured to detect the beam,

elevating the bar at least until the leaflet stops blocking the beam includes elevating the bar at least until the detector detects the beam, and

identifying the elevation includes identifying the elevation, from the beam, at which the bar was disposed when the detector detected the beam.

15 In an application, placing the leaflet across the bar includes placing the leaflet on a surface of a platform.

In an application, elevating the bar at least until the leaflet stops blocking the beam includes elevating the bar at least until a gap forms between the leaflet and the platform, and the beam passes through the gap.

20 In an application, the method further includes, prior to elevating the bar, adjusting a distance between the beam and the surface by adjusting a position of the light source with respect to the platform.

In an application, placing the leaflet on the surface of the platform includes placing the leaflet on the surface of the platform while the bar is disposed below the surface of the platform.

25 In an application, placing the leaflet across the bar includes placing the leaflet across the bar in a first orientation of the leaflet with respect to the bar, the elevation is a first elevation, and assigning the flexibility value to the leaflet includes assigning a first flexibility value to the leaflet, and the method further includes:

30 placing the leaflet across the bar in a second orientation of the leaflet with respect to the bar, and positioning the bar such that the leaflet drapes over the bar in the second orientation and blocks the beam;

while the leaflet remains draped over the bar in the second orientation, elevating the bar at least until the leaflet stops blocking the beam;

identifying a second elevation, of the bar from the beam, at which the leaflet in the second orientation stopped blocking the beam; and

5 responsively to the identified second elevation, assigning a second flexibility value to the leaflet.

In an application, in the first orientation, the leaflet is draped symmetrically over the bar, and in the second orientation, the leaflet is draped asymmetrically over the bar.

10 In an application, placing the leaflet across the bar in the first orientation includes placing the leaflet within a first guide defined by a surface of a platform, and placing the leaflet across the bar in the second orientation includes placing the leaflet within a second guide defined by the surface of the platform.

In an application:

15 placing the leaflet across the bar in the first orientation includes placing the leaflet within the first guide while the first guide is aligned with the bar;

 placing the leaflet across the bar in the second orientation includes placing the leaflet within the second guide while the second guide is aligned with the bar; and

20 the method further includes, prior to placing the leaflet across the bar in the second orientation, aligning the second guide with the bar by rotating the platform with respect to the bar.

There is further provided, in accordance with an application of the present invention, apparatus for testing a prosthetic heart valve leaflet, the apparatus including:

a platform having a surface;

a bar:

25 movably coupled to the platform,

 having an initial position with respect to the platform, in which the leaflet is placeable across the bar and in contact with the surface, and

 being movable out of the initial position and away from the surface, so as to lift the leaflet away from the surface;

30 a gauge, coupled to the platform and the bar, and configured to measure an elevation between the bar and the platform; and

a sensor, configured to detect a gap between the leaflet and the surface, and to generate a detection-signal indicative of detection of the gap.

In an application, the detection-signal is an audio signal, and the sensor is configured to generate the audio signal.

5 In an application, the detection-signal is a visual signal, and the sensor is configured to generate the visual signal.

In an application, the gauge is configured to measure an elevation-difference between (i) a present elevation between the bar and the platform, and (ii) an initial-position elevation between the bar and the platform when the bar is in the initial position.

10 In an application, the platform is shaped such that the surface is a horizontal surface, the bar is a horizontal bar, the apparatus further includes a vertical post that is coupled to and extends upward from the platform, and the bar is movably coupled to the platform by being coupled to the post and vertically slidable along the post.

In an application, the sensor:

15 includes at least one electrode positioned on the platform to be in contact with the leaflet, is configured to detect electrical contact between the leaflet and the electrode, and is configured to detect the gap by detecting a reduction in the electrical contact.

In an application, the apparatus further includes a controller, and:

the controller includes:

20 a display; and
circuitry that interfaces with the display, the gauge and the sensor, and the circuitry, upon receipt of the detection-signal, drives the display to display the elevation.

25 In an application, the circuitry drives the gauge to measure the elevation upon receipt of the detection-signal.

In an application, the gauge is configured to generate an elevation-signal indicative of the measured elevation, and the apparatus further includes a controller, the controller including circuitry configured to:

30 receive the detection-signal and the elevation-signal, and
responsively to the detection-signal and the elevation-signal, to provide an output indicative of an elevation, between the bar and the platform, at which the gap is detected.

In an application, the circuitry is configured to, in response to the detection-signal, drive the gauge to generate the elevation-signal.

In an application, the gauge is configured to generate the elevation-signal independently of the circuitry receiving the detection-signal.

5 In an application, the apparatus further includes a display, and:

the circuitry is configured to drive the display to display the elevation independently of the circuitry receiving the detection-signal, and

the circuitry is configured to provide the output by maintaining, on the display, the elevation that was measured at a time that the detection-signal was received by the circuitry.

10 In an application, the sensor includes:

a laser, configured to emit a laser beam, and positioned to direct the laser beam to pass across the surface; and

a detector, configured to detect that the laser beam has passed across the surface.

15 In an application, the laser is positioned to direct the laser beam to pass across the surface within 2 mm of the surface.

In an application, the laser is positioned to direct the laser beam to pass across the surface between 0.4 and 0.6 mm of the surface.

In an application:

the platform is shaped such that the surface is a horizontal surface,

20 the bar is a horizontal bar,

the laser is positioned to direct the laser beam horizontally,

the apparatus further includes a vertical post that is coupled to and extends upward from the platform, and

25 the bar is movably coupled to the platform by being coupled to the post and vertically slidable along the post.

In an application, sliding of the bar vertically along the post moves the bar through the laser beam.

In an application, the laser beam is orthogonal to the bar.

30 In an application, the platform defines a guide that indicates an orientation in which the leaflet is to be placed on the surface.

In an application, the leaflet has a size and a shape, and the guide has a size and a shape that match the size and the shape of the leaflet.

In an application, the guide is a marking on the surface.

In an application, the guide is a depression in the surface.

5 In an application, the guide is a first guide, the orientation is a first orientation, and the platform further defines a second guide that indicates a second orientation that is different to the first orientation.

In an application, the platform is movable between a first-guide state and a second-guide state, such that:

10 in the first-guide state, the first guide is at a location with respect to the sensor, and is in the first orientation, and

in the second-guide state, the second guide is at the location in the second orientation.

In an application, the second orientation is orthogonal to the first orientation.

15 It will be appreciated by persons skilled in the art that the present invention is not limited to what has been particularly shown and described hereinabove. Rather, the scope of the present invention includes both combinations and subcombinations of the various features described hereinabove, as well as variations and modifications thereof that are not in the prior art, which would occur to persons skilled in the art upon reading the foregoing description.

20 **BRIEF DESCRIPTION OF THE DRAWINGS**

Figs. 1, 2A-E, and 3 are schematic illustrations of a system for testing prosthetic heart valve leaflets, in accordance with some applications of the invention.

DETAILED DESCRIPTION OF EMBODIMENTS

Reference is made to Figs. 1, 2A-E, and 3, which are schematic illustrations of a system
25 20 for testing a prosthetic heart valve leaflet 10, in accordance with some applications of the invention. Fig. 1 shows system 20 alone, and Figs. 2A-E show the system being used to test leaflet 10, in accordance with some applications of the invention. Prosthetic heart valve leaflets 10 are typically cut from animal tissue such as bovine pericardium, whose flexibility naturally varies between animals, and even between regions of the tissue within the same animal.
30 Typically, system 20 is used to determine the flexibility of leaflets 10. For example, the system may be used to determine one or more flexibility values of the leaflet. The leaflet may be

categorized according to the one or more flexibility values. Such categorization is hypothesized by the inventors to facilitate construction of prosthetic valves comprising such leaflets in order to reduce or eliminate regurgitation of blood between the prosthetic leaflets of the prosthetic valve. For example, for an individual prosthetic valve, prosthetic leaflets would be selected
5 having similar or otherwise complementary flexibility values to one other.

System 20 comprises a horizontal bar 22, a sensor 23, and a gauge 28. Sensor 23 typically comprises a light source 24 and a detector 26. Bar 22 has a bar-axis ax1 that lies on a bar-plane 30. Bar 22 is movable with respect to light source 24, and bar-plane 30 is defined by the movement of axis ax1 when bar 22 is moved, as described hereinbelow. Typically, bar 22
10 is movable vertically, so bar-plane 30 is typically a vertical plane, as shown. Bar 22 is configured to support, along bar-axis ax1, the leaflet being tested such that the leaflet drapes over the bar. This draping is visible in Figs. 2D-E.

Light source 24 is configured to emit a beam 32 of light, and is oriented to direct the beam through bar-plane 30. It is to be noted that, in this context, the term "light" (including in
15 the specification and the claims) includes frequencies that are invisible to the human eye, but that are blocked by leaflet 10. Typically, light source 24 is a laser, configured to emit a laser beam.

Detector 26 is configured and positioned to detect beam 32, and is configured to generate a detection-signal indicative of detection of the beam. For example, detector 26 may
20 be directly opposite light source 24, facing the light source. Alternatively, and as shown, system 20 may comprise a reflector 36 that reflects beam 32 toward detector 26, e.g., to facilitate more convenient positioning of detector 26. For some applications, and as shown, light source 24 and detector 26 are integrated within a housing 34, and reflector 36 reflects beam 32 back toward the housing from which the beam originated.

Gauge 28 is configured to measure a distance between bar 22 and beam 32 (e.g., an
25 elevation of bar 22 above beam 32). It is to be noted that in this patent application, including in the specification and the claims, this includes measuring a distance that is indicative of the elevation of the bar above the beam, e.g., without directly measuring the specific distance between the bar and the beam. For example, if there is a fixed distance between beam 32 and
30 another element of system 20, gauge 28 may measure the distance between bar 22 and the other element.

Bar 22 is movable with respect to light source 24 and beam 32, the movement of the bar defining bar-plane 30. Typically, this is achieved by bar 22 being movably coupled to a post

(e.g., a vertical post) 38, to which light source 24 is coupled (e.g., fixedly coupled). For some applications, this is achieved by bar 22 being coupled to post 38 via a linear actuator 40, actuation of which moves the bar with respect to the post and within bar-plane 30. Actuator 40 may be mechanical, electronic, or any suitable type. Post 38 has a longitudinal axis ax2.

5 There is therefore provided, in accordance with some applications of the invention, apparatus for testing a prosthetic heart valve leaflet, the apparatus comprising:

a vertical post, having a longitudinal axis;

a horizontal bar having a bar-axis that lies on a vertical bar-plane, the bar being configured to support the leaflet along the bar-axis such that the leaflet drapes over the
10 bar;

a linear actuator, movably coupling the bar to the post, actuation of the actuator moving the bar vertically in the bar-plane;

a light source, configured to emit a beam of light, and oriented to direct the beam through the bar-plane;

15 a gauge, configured to measure an elevation of the bar above the beam; and

a detector, configured and positioned to detect the beam, and to generate a detection-signal indicative of detection of the beam.

For some applications, and as shown, bar 22 extends laterally away from post 38 (e.g., such that the post lies on bar-plane 30). For some applications, and as shown, light source 24
20 is disposed laterally from post 38. Typically, light source 24 is oriented to direct beam 32 through the bar-plane horizontally (e.g., such that the beam is perpendicular to the bar-plane). For some applications, the movement of bar 22 in the bar-plane, described hereinabove, includes movement of the bar through (e.g., vertically through) beam 32. That is, for some applications, bar 22 is coupled to post 38 such that the bar is movable, within the bar-plane,
25 through (e.g., vertically through) the beam. It is to be noted that, in practice, leaflet 10 may block beam 32 from reaching bar 22 as the bar moves through the beam.

A brief, general description of a use of system 20 is as follows: Leaflet 10 is placed across bar 22, and the bar is positioned such that the leaflet drapes over the bar and blocks beam 32 (Figs. 2B-D). While leaflet 10 remains draped over bar 22, the bar is elevated at least until
30 the leaflet stops blocking the beam (Fig. 2E). An elevation of the bar from the beam at which the leaflet stopped blocking the beam is identified, and responsively to the identified elevation, a flexibility value is assigned to the leaflet. It is hypothesized by the inventors that, a leaflet which is more flexible about the bar-plane will drape more steeply, and therefore further down,

from bar 22, thereby requiring a higher elevation above beam 32 before the leaflet stops blocking the beam.

For some applications, and as shown, system 20 comprises a platform 60 that has a surface 62 (e.g., an upper surface that is typically horizontal). Bar-plane 30 intersects platform 60, and the movement of bar 22 (e.g., via actuation of actuator 40) is with respect to the platform. Bar 22 has an initial position in which leaflet 10 is placeable across the bar and in contact with the surface. For some applications, in the initial position, bar 22 is disposed at least partly (e.g., completely) below the surface, as shown in Fig. 2A.

Typically, leaflets 10 that are to be tested using system 20 are cut from an animal tissue such as bovine pericardium. Further typically, leaflets 10 are cut to have consistent shape and size, the shape and size defining a leaflet-outline. For some applications, platform 60 has a guide 64 that defines a guide-outline 65 that corresponds to the leaflet-outline. Guide-outline 65 has a guide-outline position and a guide-outline orientation that indicate the position and orientation in which leaflet 10 is to be placed across the bar and in contact with the surface. Bar-plane 30 bisects guide-outline 65.

For some applications, system 20 has a plurality of guides 64, e.g., comprising a first guide 64a, a second guide 64b, and a third guide 64c, each of the guides at a defining a respective guide-outline 65a, 65b, and 65c. System 20 has a respective guide-state in which bar-plane 30 bisects a respective guide 64 (e.g., the guide-outline 65 thereof). For example, system 20 may have a first guide-state in which bar-plane 30 bisects guide 64a, a second guide-state in which the bar-plane bisects guide 64b, and a third guide-state in which the bar-plane bisects guide 64c. In its respective guide-state, each guide 64 is bisected by bar-plane 30 at a different angle. Typically, bar-plane 30 bisects at least one of the guides symmetrically when system 20 is in the corresponding guide-state, and bisects at least one of the other guides asymmetrically when the system is in the guide-state that corresponds to that guide.

For some such applications, and as shown, platform 60 defines the plurality of guides 64, and is movably (e.g., rotatably) coupled to post 38 via a coupling 70. System 20 is transitioned between its guide-states via movement (e.g., rotation) of platform 60, the movement bringing the respective guides 64 into alignment with bar-plane 30. Fig. 2A shows system 20 in a first guide-state, in which bar-plane 30 bisects first guide 64a (e.g., first guide-outline 65a) symmetrically. Fig. 3 shows system 20 in a second guide-state, following rotation

of platform 60, in which bar-plane 30 bisects the second guide 64b (e.g., second guide-outline 65b) asymmetrically.

Alternatively, system 20 comprises more than one platform 60, each platform defining a respective guide, and being removably couplable to a coupling (e.g., couplable to post 38 via the coupling). For such applications, each guide-state is achieved by coupling the
5 corresponding platform to the coupling.

As described hereinabove, for some applications, in the initial position, bar 22 is disposed at least partly (e.g., completely) below the surface. To achieve this, platform 60 typically defines a longitudinal hollow 66 that lies on bar-plane 30. When bar 22 is in its initial
10 position, it is disposed in hollow 66. Hollow 66 is shown as a groove in platform 60, but may alternatively be a slot cut all the way through the platform. Irrespective of whether platform 60 defines hollow 66, the initial position of bar 22 may be such that the placement of leaflet 10 across the bar places the leaflet in contact with the bar. Alternatively, the initial position of bar 22 (facilitated by the depth of hollow 66) may be such that the leaflet spans the hollow but does
15 not actually touch the bar. In this context, the leaflet being "placed across the bar" includes such a configuration.

For applications in which system 20 has more than one guide 64 (e.g., applications in which platform 60 defines more than one guide), each guide typically has a corresponding hollow 66 appropriately aligned with the corresponding guide-outline 65. For example, and as
20 shown, platform 60 may define a hollow 66a, a hollow 66b, and a hollow 66c. Transitioning of the system into a given guide-state aligns the corresponding hollow 66 with bar-plane 30.

For some applications, and as shown, each guide-outline 65 is defined by a ridge 68 that facilitates correct placement of leaflet 10, e.g., by at least partially inhibiting movement of the leaflet. For some such applications, and as shown, platform 60 defines each guide 64 as a
25 depression, ridge 68 being the boundary of the depression. Alternatively, guide-outline 65 may simply be a marking.

For some applications, light source 24 is adjustably coupled to platform 60, such that a distance between the beam of light and the surface is adjustable by adjusting a position of the light source with respect to the platform. For some applications, light source 24 is positioned
30 (or is positionable via adjustment) such that beam 32 passes across surface 62 within 2 mm of the surface, e.g., 0.1-1.5 mm (such as 0.1-1 mm, e.g., 0.1-0.5 mm, or such as 0.4-1.5 mm, e.g., 0.4-1 mm, such as 0.4-0.6 mm, such as about 0.46 mm) from the surface. For some applications,

light source 24 is positioned such that beam 32 in effect skims surface 62. For such applications, system 20 is therefore configured to detect a gap between leaflet 10 and surface 62, and is used to determine the distance (e.g., elevation) between bar 22 and platform 60 at which the gap is formed. For such applications, there is therefore provided apparatus comprising:

- 5 a platform having a surface;
- a bar:
 - movably coupled to the platform,
 - having an initial position with respect to the platform, in which the leaflet is placeable across the bar and in contact with the surface, and
 - 10 being movable out of the initial position and away from the surface, so as to lift the leaflet away from the surface;
 - a gauge, coupled to the platform and the bar, and configured to measure a distance between the bar and the platform; and
 - a sensor, configured to detect a gap between the leaflet and the surface, and to
 - 15 generate a detection-signal indicative of detection of the gap.

For some applications, detection of the gap is achieved through means other than detecting the unblocking of a beam of light. For example, instead of light source 24 and detector 26, sensor 23 may comprise at least one electrode positioned on platform 60 such that the electrode is in contact with leaflet 10 when the leaflet is placed across the bar and in contact

20 with the platform. Via the electrode, the sensor detects electrical contact between the leaflet and the electrode, and detects the gap by detecting a reduction in (e.g., loss of) the electrical contact.

Fig. 2A shows system 20, in a first guide-state, with bar 22 in its initial position. Bar 22 is disposed in hollow 66, and is completely below surface 62 of platform 60. Leaflet 10 is

25 positioned within guide-outline 65a of guide 64a, thereby placing the leaflet across bar 22 (Fig. 2B).

For some applications, and as shown, system 20 further comprises a clamping element 72, movably coupled to bar 22, and configured to clamp leaflet 10 to the bar. Fig. 2C shows a

30 step in which clamping element is moved toward the bar in order to clamp the leaflet to the bar, to prevent the leaflet from slipping off the bar when the bar is elevated. As shown, the clamping element may comprise a rod, parallel to the bar, and configured to clamp the leaflet against the bar along bar-axis ax1. For some applications, system 20 comprises a spring that provides a

clamping force to element 72, the clamping force having a magnitude sufficiently great to secure leaflet 10, but sufficiently small to avoid damaging the leaflet.

Bar 22 is positioned such that leaflet 10 drapes over the bar and blocks beam 32. For some applications, in the initial position of bar 22, the bar is positioned in this manner.
5 Alternatively, and as shown in Fig. 2D, bar 22 is positioned in this manner by elevating the bar.

While leaflet 10 remains draped over bar 22, the bar is elevated at least until the leaflet stops blocking beam 32 (Fig. 2E). Detector 26 detects beam 32, and responsively generates a detection-signal, indicative of detection of the beam. For some applications, the detection-signal is an audio signal. For some applications, the detection signal is a visual signal.

10 For some applications, the operator stops elevating bar 22 (e.g., actuating actuator 40) upon perceiving the detection-signal, reads the elevation measured by gauge 28, and responsively assigns a flexibility value to the leaflet.

For some applications, system 20 is at least partly automated, e.g., by electronically coupling sensor 23 to gauge 28. This is represented by a cable 86 connecting housing 34 to
15 controller 80, but it is to be understood that the scope of the invention includes other means, both wired and wireless, of electronically coupling the sensor to the controller. For example, system 20 may comprise a controller 80 that comprises a display 82, and circuitry 84 that interfaces with the display, gauge 28, and sensor 23 (e.g., detector 26 thereof). Controller 80 (e.g., circuitry 84) is configured to receive the detection-signal, and to responsively drive
20 display 82 to display the elevation of bar 22, with respect to beam 32, at which the beam was detected.

For example, gauge 28 may continuously (or repeatedly) measure the elevation of bar 22 with respect to beam 32, e.g., continuously providing an elevation-signal. Upon receipt of the detection-signal, controller 80 (e.g., circuitry 84) drives display 82 to display the elevation
25 at which the beam was detected (i.e., the elevation measured at the time that the detection-signal was received by the controller), and continues to display that elevation even if bar 22 is moved further. Alternatively, gauge 28 may only measure the elevation in response to the detection-signal (e.g., controller 80 may be configured to, in response to receiving the detection-signal, drive gauge 28 to measure the elevation).

30 There is therefore provided, in accordance with some applications of the invention, apparatus comprising:

a bar having a bar-axis, the bar being configured to support a prosthetic heart valve leaflet along the bar-axis such that the leaflet drapes over the bar;

a light source, configured to emit a beam of light;

a detector, configured to detect the beam, and to generate a detection-signal indicative of detection of the beam;

a linear actuator, movably coupling the bar to the light source, actuation of the actuator moving the bar with respect to the beam;

a gauge, configured to measure an elevation of the bar above the beam, the elevation changing with the moving of the bar by the actuator;

a display, and

circuitry, electrically connected to the detector, the gauge, and the display, and configured:

to receive, from the gauge, the measured elevation,

to receive the detection-signal from the detector, and

in response to the detection-signal, to drive the display to display the elevation that was measured when the detection-signal was received by the circuitry.

It is to be understood that display 82 is merely an example of an output that controller 80 (e.g., circuitry 84 thereof) may provide in response to receipt of the detection-signal, and that the scope of the invention includes the controller providing other outputs, such as an electronic output signal that is received by a computer system.

As described hereinabove, the flexibility of animal tissue from which leaflets 10 are typically cut is naturally variable. Moreover, such tissue may have anisotropic flexibility, and therefore each leaflet 10 may be more flexible on one axis than on another. It is hypothesized by the inventors that testing the flexibility of leaflets on more than one axis advantageously improves matching of complementary leaflets for use within a single prosthetic valve. Therefore, as described hereinabove, for some applications system 20 has a plurality of guides 64 and a plurality of guide-states, for testing the flexibility of leaflet 10 in different orientations (e.g., rotational orientations) with respect to bar 22. In the example shown, system 20 has three guides 64 and three guide-states. Fig. 3 shows system 20 after it has been transitioned into another guide-state by rotating platform 60 such that guide 64b is aligned with (and bisected by) bar-plane 30. The steps described with reference to Figs. 2B-E are typically repeated for each guide state. When in its corresponding guide-state, guide 64b is disposed with respect to

bar-plane 30 at an orientation that is orthogonal to that of guide 64a in its corresponding guide-state. When in its corresponding guide-state, guide 64c is disposed with respect to bar-plane 30 at an orientation that is between that of guide 64a in its corresponding guide-state, and that of guide 64b in its corresponding guide state.

5 For some applications, for one or more of the guide states, leaflet 10 is tested one side up and the other side up.

For some applications, system 20 does not comprise post 38, and another mechanism is used to movably couple bar 22 to light source 24.

10 It will be appreciated by persons skilled in the art that the present invention is not limited to what has been particularly shown and described hereinabove. Rather, the scope of the present invention includes both combinations and subcombinations of the various features described hereinabove, as well as variations and modifications thereof that are not in the prior art, which would occur to persons skilled in the art upon reading the foregoing description.

CLAIMS

1. Apparatus for testing a prosthetic heart valve leaflet, the apparatus comprising:
 - a bar having a bar-axis, the bar being configured to support the leaflet along the bar-axis such that the leaflet drapes over the bar;
 - 5 a light source, configured to emit a beam of light;
 - a detector, configured to detect the beam, and to generate a detection-signal indicative of detection of the beam;
 - a linear actuator, movably coupling the bar to the light source, actuation of the actuator moving the bar with respect to the beam;
 - 10 a gauge, configured to measure an elevation of the bar above the beam, the elevation changing with the moving of the bar by the actuator;
 - a display; and
 - circuitry, electrically connected to the detector, the gauge, and the display, and configured:
 - 15 to receive, from the gauge, the measured elevation,
 - to receive the detection-signal from the detector, and
 - in response to the detection-signal, to drive the display to display the elevation that was measured when the detection-signal was received by the circuitry.
2. The apparatus according to claim 1, wherein the linear actuator is configured such that
20 the actuation of the actuator moves the bar through the beam.
3. The apparatus according to any one of claims 1-2, wherein the gauge is configured to continuously measure the elevation, and wherein the circuitry is configured to continuously receive the measured elevation.
4. The apparatus according to claim 3, wherein the circuitry is configured:
 - 25 while the detection-signal is not received by the circuitry, to continuously drive the display to display the continuously-measured elevation, and
 - in response to the detection-signal, to maintain, on the display, the elevation that was measured at a time that the detection-signal was received by the circuitry.
5. A method for determining a flexibility of a prosthetic heart valve leaflet, the method
30 comprising:

placing the leaflet across a bar, and positioning the bar such that the leaflet drapes over the bar and blocks a beam of light emitted by a light source;

while the leaflet remains draped over the bar, elevating the bar at least until the leaflet stops blocking the beam;

5 identifying an elevation, of the bar from the beam, at which the leaflet stopped blocking the beam; and

responsively to the identified elevation, assigning a flexibility value to the leaflet.

6. The method according to claim 5, wherein elevating the bar at least until the leaflet stops blocking the beam comprises moving the bar through the beam.

10 7. The method according to claim 5, wherein the bar is movably coupled to a post via a linear actuator, and wherein elevating the bar comprises actuating the linear actuator.

8. The method according to claim 5, wherein the light source is a laser, and the beam of light is a laser beam, and wherein:

15 positioning the bar such that the leaflet blocks the beam of light comprises positioning the bar such that the leaflet blocks the laser beam; and

elevating the bar at least until the leaflet stops blocking the beam comprises elevating the bar at least until the leaflet stops blocking the laser beam.

9. The method according to claim 5, further comprising clamping the leaflet to the bar.

20 10. The method according to claim 5, wherein determining the flexibility of the leaflet comprises determining the flexibility of a first leaflet, and wherein the method further comprises:

determining a flexibility of a second prosthetic heart valve leaflet;

identifying that the flexibility of the first leaflet and the flexibility of the second leaflet are within a threshold flexibility difference of each other; and

25 in response to the identifying, assembling a prosthetic heart valve by attaching the first leaflet and the second leaflet to a frame.

11. The method according to claim 5, wherein:

positioning the bar such that the leaflet blocks the beam comprises positioning the bar such that the leaflet blocks the beam from reaching a detector configured to detect the beam,

30 elevating the bar at least until the leaflet stops blocking the beam comprises elevating the bar at least until the detector detects the beam, and

identifying the elevation comprises identifying the elevation, from the beam, at which the bar was disposed when the detector detected the beam.

12. The method according to any one of claims 5-11, wherein placing the leaflet across the bar comprises placing the leaflet on a surface of a platform.

5 13. The method according to claim 12, wherein elevating the bar at least until the leaflet stops blocking the beam comprises elevating the bar at least until a gap forms between the leaflet and the platform, and the beam passes through the gap.

14. The method according to claim 13, further comprising, prior to elevating the bar, adjusting a distance between the beam and the surface by adjusting a position of the light source
10 with respect to the platform.

15. The method according to claim 12, wherein placing the leaflet on the surface of the platform comprises placing the leaflet on the surface of the platform while the bar is disposed below the surface of the platform.

16. The method according to any one of claims 5-11, wherein placing the leaflet across the
15 bar comprises placing the leaflet across the bar in a first orientation of the leaflet with respect to the bar, the elevation is a first elevation, and assigning the flexibility value to the leaflet comprises assigning a first flexibility value to the leaflet, and wherein the method further comprises:

placing the leaflet across the bar in a second orientation of the leaflet with respect to the
20 bar, and positioning the bar such that the leaflet drapes over the bar in the second orientation and blocks the beam;

while the leaflet remains draped over the bar in the second orientation, elevating the bar at least until the leaflet stops blocking the beam;

25 identifying a second elevation, of the bar from the beam, at which the leaflet in the second orientation stopped blocking the beam; and

responsively to the identified second elevation, assigning a second flexibility value to the leaflet.

17. The method according to claim 16, wherein in the first orientation, the leaflet is draped symmetrically over the bar, and in the second orientation, the leaflet is draped asymmetrically
30 over the bar.

18. The method according to claim 16, wherein placing the leaflet across the bar in the first orientation comprises placing the leaflet within a first guide defined by a surface of a platform,

and wherein placing the leaflet across the bar in the second orientation comprises placing the leaflet within a second guide defined by the surface of the platform.

19. The method according to claim 18, wherein:

placing the leaflet across the bar in the first orientation comprises placing the leaflet within the first guide while the first guide is aligned with the bar;

placing the leaflet across the bar in the second orientation comprises placing the leaflet within the second guide while the second guide is aligned with the bar; and

the method further comprises, prior to placing the leaflet across the bar in the second orientation, aligning the second guide with the bar by rotating the platform with respect to the bar.

20. Apparatus for testing a prosthetic heart valve leaflet, the apparatus comprising:

a platform having a surface;

a bar:

movably coupled to the platform,

having an initial position with respect to the platform, in which the leaflet is placeable across the bar and in contact with the surface, and

being movable out of the initial position and away from the surface, so as to lift the leaflet away from the surface;

a gauge, coupled to the platform and the bar, and configured to measure an elevation between the bar and the platform; and

a sensor, configured to detect a gap between the leaflet and the surface, and to generate a detection-signal indicative of detection of the gap.

21. The apparatus according to claim 20, wherein the detection-signal is an audio signal, and wherein the sensor is configured to generate the audio signal.

22. The apparatus according to claim 20, wherein the detection-signal is a visual signal, and wherein the sensor is configured to generate the visual signal.

23. The apparatus according to claim 20, wherein the gauge is configured to measure an elevation-difference between (i) a present elevation between the bar and the platform, and (ii) an initial-position elevation between the bar and the platform when the bar is in the initial position.

24. The apparatus according to claim 20, wherein the platform is shaped such that the surface is a horizontal surface, the bar is a horizontal bar, the apparatus further comprises a vertical post that is coupled to and extends upward from the platform, and the bar is movably coupled to the platform by being coupled to the post and vertically slidable along the post.
- 5 25. The apparatus according to claim 20, wherein the sensor:
comprises at least one electrode positioned on the platform to be in contact with the leaflet,
is configured to detect electrical contact between the leaflet and the electrode, and
is configured to detect the gap by detecting a reduction in the electrical contact.
- 10 26. The apparatus according to any one of claims 20-25, further comprising a controller, wherein:
the controller comprises:
a display; and
circuitry that interfaces with the display, the gauge and the sensor, and
15 the circuitry, upon receipt of the detection-signal, drives the display to display the elevation.
27. The apparatus according to claim 26, wherein the circuitry drives the gauge to measure the elevation upon receipt of the detection-signal.
28. The apparatus according to any one of claims 20-25, wherein the gauge is configured to
20 generate an elevation-signal indicative of the measured elevation, and wherein the apparatus further comprises a controller, the controller comprising circuitry configured to:
receive the detection-signal and the elevation-signal, and
responsively to the detection-signal and the elevation-signal, to provide an output indicative of an elevation, between the bar and the platform, at which the gap is detected.
- 25 29. The apparatus according to claim 28, wherein the circuitry is configured to, in response to the detection-signal, drive the gauge to generate the elevation-signal.
30. The apparatus according to claim 28, wherein the gauge is configured to generate the elevation-signal independently of the circuitry receiving the detection-signal.
31. The apparatus according to claim 30, further comprising a display, wherein:
30 the circuitry is configured to drive the display to display the elevation independently of the circuitry receiving the detection-signal, and

the circuitry is configured to provide the output by maintaining, on the display, the elevation that was measured at a time that the detection-signal was received by the circuitry.

32. The apparatus according to any one of claims 20-25, wherein the sensor comprises:
a laser, configured to emit a laser beam, and positioned to direct the laser beam to pass
5 across the surface; and
a detector, configured to detect that the laser beam has passed across the surface.
33. The apparatus according to claim 32, wherein the laser is positioned to direct the laser beam to pass across the surface within 2 mm of the surface.
34. The apparatus according to claim 33, wherein the laser is positioned to direct the laser
10 beam to pass across the surface between 0.4 and 0.6 mm of the surface.
35. The apparatus according to claim 32, wherein:
the platform is shaped such that the surface is a horizontal surface,
the bar is a horizontal bar,
the laser is positioned to direct the laser beam horizontally,
15 the apparatus further comprises a vertical post that is coupled to and extends upward
from the platform, and
the bar is movably coupled to the platform by being coupled to the post and vertically
slidable along the post.
36. The apparatus according to claim 35, wherein sliding of the bar vertically along the post
20 moves the bar through the laser beam.
37. The apparatus according to claim 35, wherein the laser beam is orthogonal to the bar.
38. The apparatus according to any one of claims 20-25, wherein the platform defines a
guide that indicates an orientation in which the leaflet is to be placed on the surface.
39. The apparatus according to claim 38, wherein the leaflet has a size and a shape, and the
25 guide has a size and a shape that match the size and the shape of the leaflet.
40. The apparatus according to claim 38, wherein the guide is a marking on the surface.
41. The apparatus according to claim 38, wherein the guide is a depression in the surface.
42. The apparatus according to claim 38, wherein the guide is a first guide, the orientation
is a first orientation, and the platform further defines a second guide that indicates a second
30 orientation that is different to the first orientation.

43. The apparatus according to claim 42, wherein the platform is movable between a first-guide state and a second-guide state, such that:

in the first-guide state, the first guide is at a location with respect to the sensor, and is in the first orientation, and

5 in the second-guide state, the second guide is at the location in the second orientation.

44. The apparatus according to claim 42, wherein the second orientation is orthogonal to the first orientation.

45. Apparatus for testing a prosthetic heart valve leaflet, the apparatus comprising:

a vertical post, having a longitudinal axis;

10 a horizontal bar having a bar-axis that lies on a vertical bar-plane, the bar being configured to support the leaflet along the bar-axis such that the leaflet drapes over the bar;

a linear actuator, movably coupling the bar to the post, actuation of the actuator moving the bar vertically in the bar-plane;

15 a light source, configured to emit a beam of light, and oriented to direct the beam through the bar-plane;

a gauge, configured to measure an elevation of the bar above the beam; and

a detector, configured and positioned to detect the beam, and to generate a detection-signal indicative of detection of the beam.

20 46. The apparatus according to claim 45, wherein the bar extends laterally away from the post.

47. The apparatus according to claim 45, wherein the light source is disposed laterally from the post.

48. The apparatus according to claim 45, wherein the light source is oriented to direct the beam horizontally through the bar-plane.

25 49. The apparatus according to claim 45, wherein the coupling, by the actuator, of the bar to the post, is such that the moving of the bar vertically in the bar-plane includes moving the bar vertically through the beam.

50. The apparatus according to claim 45, wherein the light source comprises a laser, and the light beam comprises a laser beam.

30 51. The apparatus according to any one of claims 45-50, further comprising a platform having a surface, the platform coupled to the post such that the bar-plane intersects the platform,

the actuation of the actuator moving the bar vertically, in the bar-plane, with respect to the platform.

52. The apparatus according to claim 51, wherein the light source is adjustably coupled to the platform, such that a distance between the beam of light and the surface is adjustable by
5 adjusting a position of the light source with respect to the platform.
53. The apparatus according to claim 51, wherein the bar has an initial position with respect to the platform, in which the leaflet is placeable across the bar and in contact with the surface.
54. The apparatus according to claim 53, wherein, in the initial position, the bar is disposed below the surface.
- 10 55. The apparatus according to claim 53, wherein the platform has a guide that defines a guide-outline that (i) corresponds to a leaflet-outline of the leaflet, and (ii) has a guide-outline position and a guide-outline orientation that indicate, respectively, a leaflet-outline position and a leaflet-outline orientation in which the leaflet is to be placed when the leaflet is placed across the bar and in contact with the surface.
- 15 56. The apparatus according to claim 55, wherein the platform is coupled to the post such that the bar-plane bisects the guide-outline.
57. The apparatus according to claim 56, wherein the platform is coupled to the post such that the bar-plane bisects the guide-outline symmetrically.
58. The apparatus according to claim 56, wherein:
20 the platform is a first platform,
the guide is a first guide,
the guide-outline is a first guide-outline,
the apparatus further comprises a coupling,
the first platform is removably couplable to the post via the coupling
25 when the first platform is coupled to the post via the coupling, the bar-plane bisects the first guide-outline at a first angle,
the apparatus further comprises a second platform that has a second guide that defines a second guide-outline that corresponds to the leaflet-outline of the leaflet,
the second platform is removably couplable to the post via the coupling, and
30 when the second platform is coupled to the post via the coupling, the bar-plane bisects the second guide-outline at a second angle.

59. The apparatus according to claim 56, wherein:
the guide is a first guide,
the guide-outline is a first guide-outline,
the platform has a second guide that defines a second guide-outline that corresponds to
5 the leaflet-outline of the leaflet,
the apparatus has a first guide-state in which the bar-plane bisects the first guide-outline,
the apparatus has a second guide-state in which the bar-plane bisects the second guide-
outline, and
the apparatus further comprises a coupling via which the platform is movably coupled
10 to the post, such that movement of the platform with respect to the post transitions the apparatus
between the first guide-state and the second guide-state.
60. The apparatus according to claim 59, wherein in the first guide-state, the bar-plane
bisects the first guide-outline at a first angle, and in the second guide-state, the bar-plane bisects
the second guide-outline at a second angle.
- 15 61. The apparatus according to claim 59, wherein in the first guide-state, the bar-plane
bisects the first guide-outline symmetrically, but in the second guide-state, the bar-plane bisects
the second guide-outline asymmetrically.
62. The apparatus according to claim 59, wherein the coupling is a rotating coupling, and
wherein rotation of the platform with respect to the post via the rotating coupling transitions the
20 apparatus between the first guide-state and the second guide-state.
63. The apparatus according to claim 55, wherein the platform defines a longitudinal hollow
that lies on the bar-plane, and wherein the bar, in its initial position, is disposed in the hollow.
64. The apparatus according to any one of claims 45-50, further comprising a clamping
element, movably coupled to the bar, and configured to clamp the leaflet to the bar.
- 25 65. The apparatus according to claim 64, wherein the clamping element comprises a rod,
parallel to the bar, and configured to clamp the leaflet against the bar along the bar-axis.
66. The apparatus according to claim 64, further comprising a spring that provides a
clamping force to clamping element.

1/7

FIG. 1

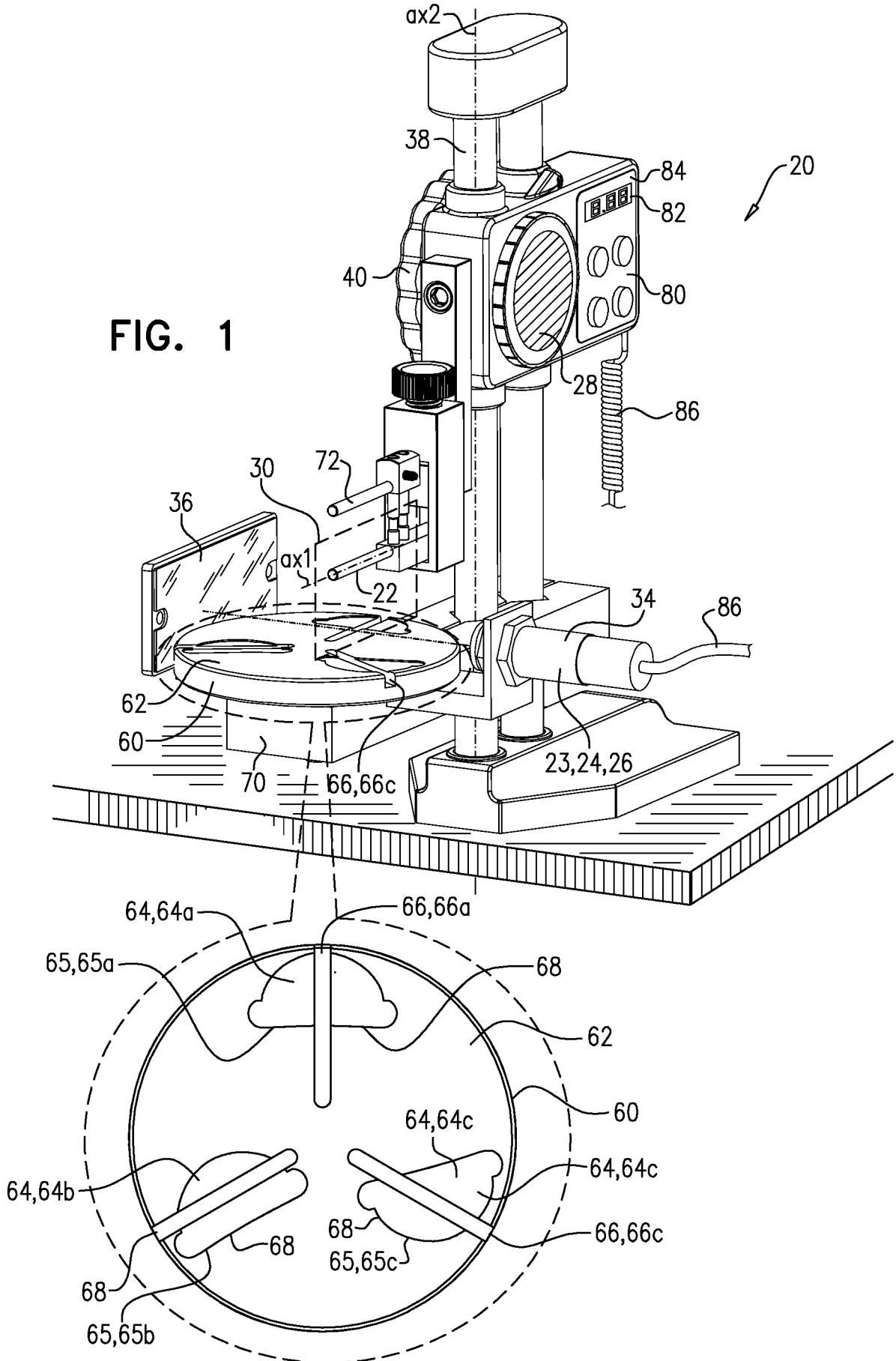

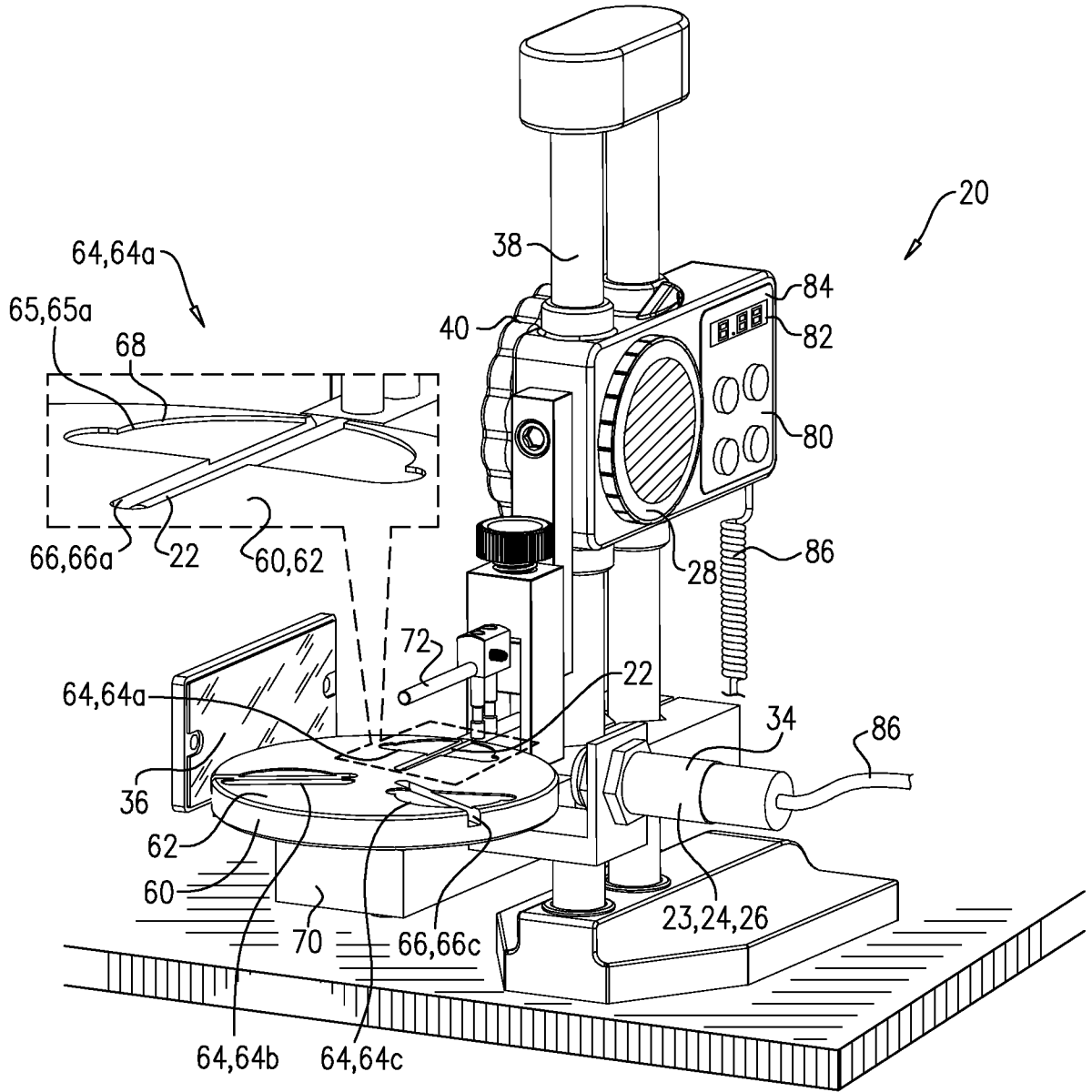
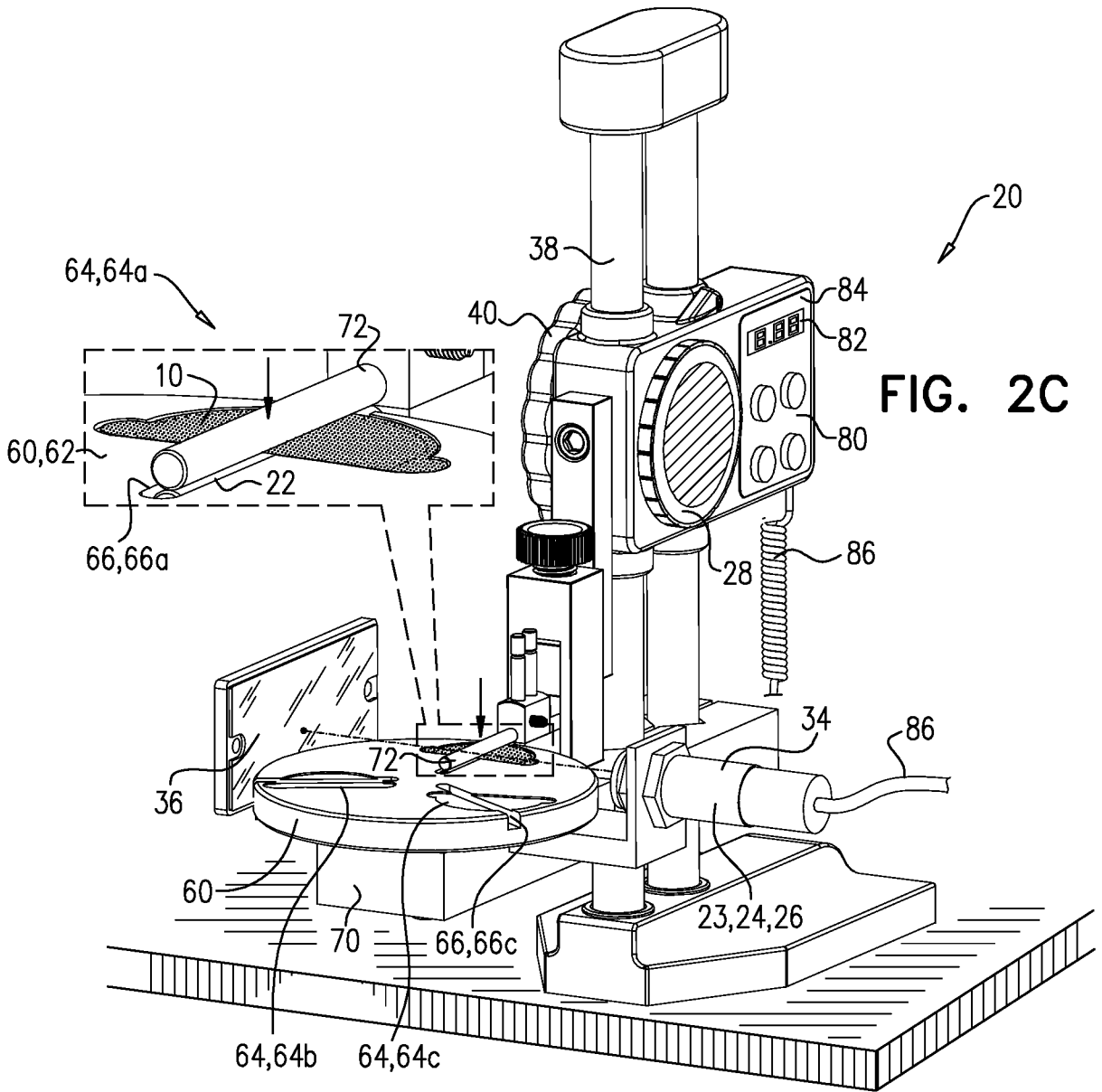
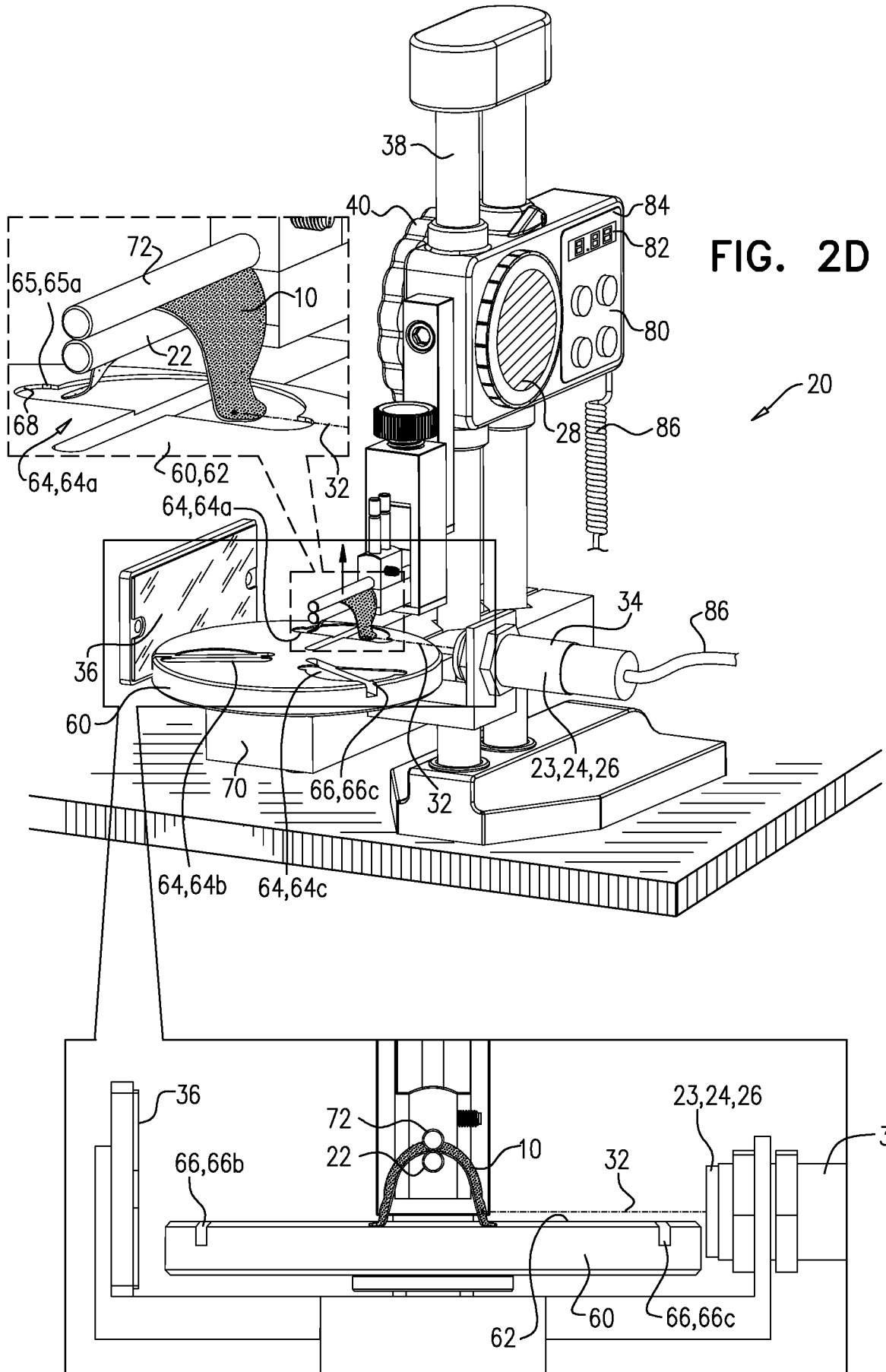

FIG. 2A



5/7



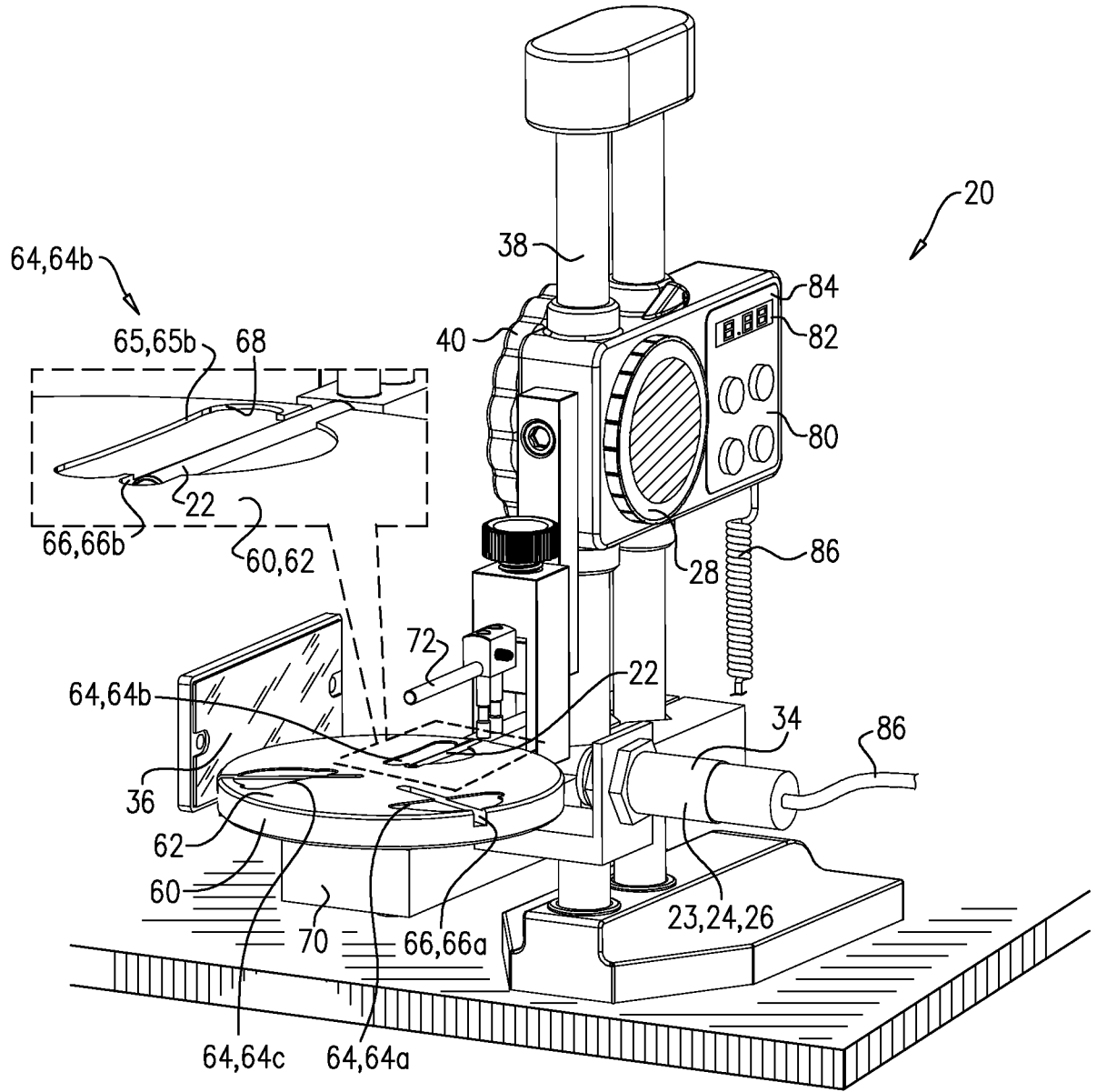

FIG. 3

