

[54] **REFRIGERATED DISPLAY CASE**  
[72] Inventor: **Fayez F. Ibrahim, Niles, Mich.**  
[73] Assignee: **Clark Equipment Company**  
[22] Filed: **Dec. 3, 1970**  
[21] Appl. No.: **94,711**

3,365,908 1/1968 MacMaster.....62/256  
3,528,258 9/1970 Brennan .....62/256

*Primary Examiner*—William J. Wye  
*Attorney*—Kenneth C. Witt, John C. Wiessler, Robert H. Johnson and Lewis Buchanan

[52] U.S. Cl.....**62/256, 62/256**  
[51] Int. Cl.....**A47I 3/04**  
[58] Field of Search.....**62/255, 256**

[57] **ABSTRACT**

This is a refrigerated display case with a front opening for unimpeded access to the refrigerated area and a movable closure section rear opening to provide intermittent access to the refrigerated area. The case has a curtain of refrigerated air across the front access opening and air conduits along the side of the rear opening to provide recirculation of the refrigerated air. The case has a separate horizontal curtain of refrigerated air across the lower portion of the refrigerated space to provide two vertically adjacent zones of refrigeration within the refrigerated space. The case also has a curtain of non-refrigerated air under the bottom of the refrigerated space to remove spillover cold air from the floor in front of the case.

[56] **References Cited**

**UNITED STATES PATENTS**

2,882,696	4/1959	Hermann.....	62/256
2,993,349	7/1961	Detwiler.....	62/256
3,063,254	11/1962	Dickson.....	62/256
3,063,255	11/1962	Fanick.....	62/256
3,229,475	1/1966	Balk.....	62/256
3,304,736	2/1967	Brennan.....	62/256

**5 Claims, 3 Drawing Figures**

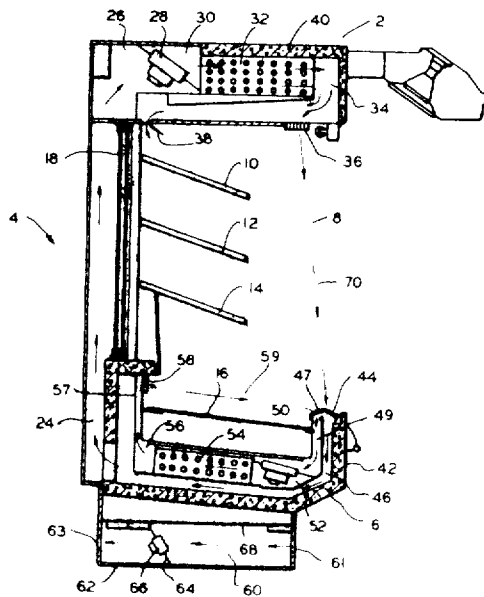

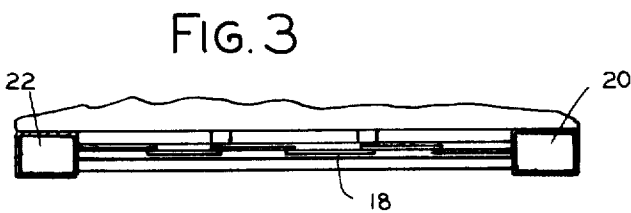
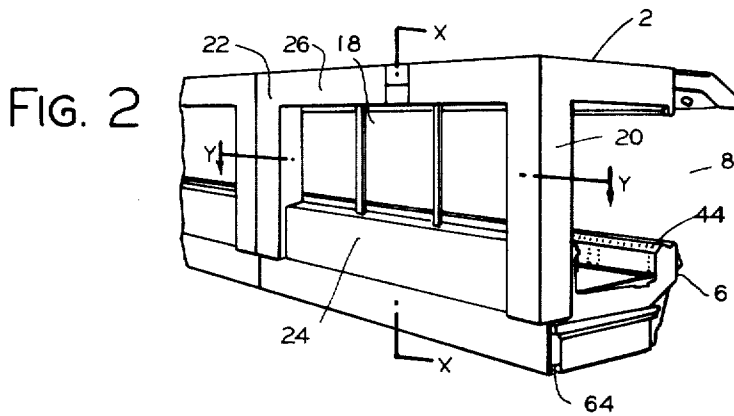
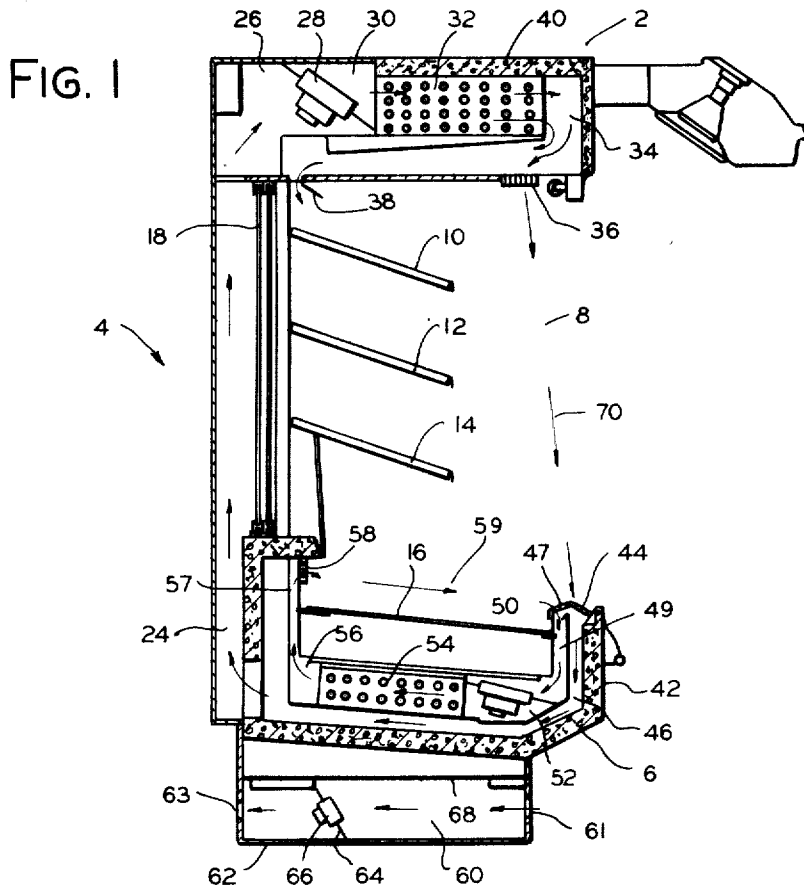

INVENTOR  
FAYEZ F. IBRAHIM  
BY *Lewis J. Lamm*  
ATTORNEY

## REFRIGERATED DISPLAY CASE

## BACKGROUND AND SUMMARY OF THE INVENTION

This invention relates to refrigerated display cases of the type having an opening in front for unimpeded access to the refrigerated space. In the present invention there is a curtain of refrigerated air circulated downwardly across this opening and downwardly through the refrigerated space then through ductwork in the base of the case and back up again through air ducts at the rear of the case. A second and independent refrigerated air circulation system provides a horizontal air curtain across the bottom area of the refrigerated space to form a separate zone of refrigeration in the display area. The case also has movable closures across an opening in the rear of the refrigerated space to provide access from the rear for replenishing the case. In one particular embodiment of the case, forced circulation of nonrefrigerated air is provided under the case to remove cold air from the floor area adjacent the front of the case.

Representative of the closest known prior art is the following reference material: U.S. Pat. No. 3,358,467, to Hickox et al. discloses a refrigerated case having horizontal circulation of refrigerated air.

U.S. Pat. No. 3,392,543, to Miller discloses a case having refrigerated air used both as an air curtain and directed to flow across the material under refrigeration.

U.S. Pat. No. 3,392,544, to Perez discloses the use of two air curtains.

U.S. Pat. No. 3,528,258, to Brennan discloses the use of two vertical air curtains disposed 90° with respect to each other.

In the present invention, there are two separate and distinct refrigerated air curtain systems. The first of these systems provides a vertical curtain of refrigerated air across the access opening at the front of the refrigerated display case. The second of these circulating systems provides a horizontal curtain of refrigerated air which flows across the bottom of the refrigerated display area. One modification of the present invention has movable closure access openings at the rear of the refrigerated case with vertical return air ducts located at the sides of the access openings.

Another modification of the present invention provides for a third air circulating system which circulates unrefrigerated air across the bottom of the case.

It is, therefore, an object of the present invention to provide a refrigerated display case with two vertically displaced refrigeration zones of display area.

It is another object of the present invention to provide a refrigerated display case having a vertical curtain of refrigerated air across the front of the case and a horizontal curtain of refrigerated air across the bottom area of the refrigerated space.

It is a further object of the present invention to provide a refrigerated case having unimpeded access to the front of the case and limited access to the rear of the case with two zones of refrigeration within said case.

It is a further object of the present invention to provide a refrigerated case having a curtain of nonrefrigerated air circulating under said case.

Further objects of the present invention will become apparent upon inspection of the drawing and specification, and will be pointed out in the claims.

## BRIEF DESCRIPTION OF PREFERRED EMBODIMENT

Referring to the drawing,

FIG. 1 is a transverse cross section of the refrigerated display case;

FIG. 2 is a rear three quarter view of the case; and

FIG. 3 is a longitudinal cross section of the back of the case.

FIG. 1 is essentially the cross section XX of FIG. 2 and FIG. 3 essentially the cross section YY of FIG. 2.

Part 2 is the top of the display case, while 4 is the rear wall and 6 is the bottom or base. The present case is the type used for displaying and merchandising refrigerated items, particu-

larly food stuff. This case has an unimpeded access opening 8 in the front thereof and shelves 10, 12 and 14 in the upper part of the cabinet for the storage and display of merchandise. It also has a shelf or support 16 which is refrigerated by a separate and distinct system and is designed for the storage and display of merchandise which may be maintained at a lower temperature than that merchandise stored on shelves 10, 12 and 14.

A horizontal curtain of refrigerated air circulating across the merchandise on shelf 16 is independent from the vertical air curtain and the merchandise on this shelf can, therefore, be maintained at a preselected lower temperature than that maintained for the merchandise stored on shelves 10, 12 and 14.

This dual air curtain system is a novel feature of this refrigerated case construction.

Another novel feature of this case is the rear wall 4 which contains sliding windows or doors 18 for access to the refrigerated space from the rear of the case to expedite replenishing the supply of merchandise stored in the case. The back or rear wall of the case also contains cold air return ducts 20 and 22. These ducts 20 and 22 are structural members which support the top 2 of the case. The cold air circulating upwardly through these ducts first enters a plenum chamber 24 below the ducts from which it flows into the ducts and then upward through the ducts 20 and 22 into a top plenum chamber 26.

## SPECIFIC DESCRIPTION OF THE PREFERRED EMBODIMENT

Referring now to FIG. 1, the top of the case 2 includes, in addition to the plenum chamber 26, an air circulating fan 28, a second chamber 30, evaporator coils 32, a cold air chamber 34, directional air louvers 36, and air outlets 38. The top of the case is covered by an insulating wall 40. The bottom or base of the case 6 is also covered with an insulating wall here indicated as 42. The bottom of the case 6 in addition to containing shelves 16, has an air inlet grill work 44 in communication with a cold air passage 46 which in turn is in communication with the plenum chamber 24.

The base of this case has a self-contained refrigerated air system containing inlet ports 47, a plenum chamber 48, an air circulating fan 50, a second plenum chamber 52, an evaporator 54, an outlet plenum chamber 56, and directional parts 58.

Located in the base below the cold air chambers and insulated therefrom is a nonrefrigerated air circulating system. This nonrefrigerated air circulating system includes an inlet chamber 60, an outlet chamber 62, and a baffle 64 therebetween all extending the length of the case. Located in the baffle 64 is an air circulating fan 66. The function of this air circulating system is to pull ambient air in at the front of the bottom of the case and exhaust it at the rear and thus remove the cold air which may otherwise appear on the floor area extending along the bottom of the case. A major function of this nonrefrigerated air circulation system is to remove this cold air which spills out of the access opening in front of the case onto the floor. The removal of this cold air from in front of the case promotes the comfort of the shopper since this cold air is then replaced by warm ambient air.

## OPERATION OF THE PREFERRED EMBODIMENT

Referring to the drawing, the refrigerated display case illustrated has two separate and distinct refrigerated air cooling systems and one nonrefrigerated air circulation system.

The first of the refrigerated air systems provides a curtain of refrigerated air across the access opening of the case and also provides for maintaining the upper part of the case a desired storage temperature, which in the preferred embodiment of the invention, may be 35° to 50° F. The air in this system is circulated by fan 28 maintaining the pressure of the air in the chamber 30 above that of the air in the chamber 26. The air circulates in the chamber 30 past the evaporator coils 32 where the air is refrigerated. The air circulates out of the

evaporator 32 into the chamber 34. Part of the air in chamber 34 is formed into a cold air curtain by means of directional louvers 36 in the lower part of the chamber. This air is directed across the access opening 8 to form a continuous air curtain 70 which tends to keep the high temperature ambient air from entering the refrigerated space lying between this air curtain and the rear of the case, and containing the shelves 10, 12 and 14. Part of the air from the chamber 34 flows through the openings 38, which together with the air curtain 70, maintains the temperature in the space behind the air curtain at the desired cold temperature. The inlet orifices 44, located along the lip of the base 6 exhausts the same amount of air that has been previously introduced through the openings 36 and 38 to aid in maintaining the continuity of the air curtain 70 and to provide air balance within the case. The air entering the orifices 44 travels through ductwork 46 across the bottom of the base to the plenum chamber 24 extending along the rear of the base. This air then travels upwardly through ducts 20 and 22 on either side of the access doors or windows 18 to the chamber 26 which extends the length of the case between the two ducts 20 and 22. The fan 28 then moves the air from the chamber 26 to chamber 30 and the air circulation cycle repeats.

If a refrigerated space such as storage space or meat cutting room is located to the rear of the case and the air in this room is maintained at substantially the same pressure and temperature as that desired in the portion of the case including the shelves 10, 12 and 14, then the doors or windows 18 may be omitted and continuous access between the rear of the case to the case permitted. Under normal operations where the air temperature and pressure to the rear of the case is not maintained at substantially that appearing within the case, then the sliding doors or windows must be provided for intermittent access for replenishing the supply of material carried on the shelves 10, 12, 14 and 16.

A separate and distinct refrigerated air curtain system is provided in the base of the case to prevent this area becoming a dead air space and also to permit the temperature of this area of the case to be maintained at a lower temperature than that maintained in the upper part of the case. For example, it may be desired to store frozen food on the shelf 16 and retain it in the frozen condition until removed by the customer through the access opening 8. The air in this system may also be maintained at the same temperature as that in the upper system with a minimum of interference between the air circulation of the two systems.

In the lower system, air is exhausted from the area surrounding the shelf 16 through the opening 47 in the front lip of the base 6. This air proceeds to the plenum chamber 48 through the duct 49. The fan 50 transfers the air from the chamber 48 to chamber 52, thus maintaining the pressure in the chamber 52 above that appearing in the chamber 48. The air from chamber 52 is then forced through the evaporator 54 to a chamber 56 extending longitudinally along the case to the rear of evaporator 54. The cold air in this chamber 56 then proceeds upwardly through the duct 57 and out into the storage space along the bottom of the case through the directional louvers 58 to form a horizontal air curtain 59 extending across the top of the space including the shelf 16. This air curtain 59 is exhausted from the space through orifices 47 and the air circulation cycle repeats itself. Since the weight of air per unit volume varies inversely with temperature, cold air tends to settle to the bottom of an air mass. For this reason, the horizontal air curtain circulating across the top of the shelf 16 may be maintained at below 32° F. to maintain the frozen material stored on this shelf in the frozen condition while the material stored on shelves 10, 12 and 14 are maintained at a temperature above freezing. This permits the case which is the subject of the present invention to be used as a combined frozen food and refrigerated food display case.

Since cold air is heavier than warm air, the refrigerated air in the case will tend to spill over the bottom of the access opening in the front of the case and collect along the floor ad-

jacent the base. This collection of cold air must be removed to prevent discomfort to shoppers removing material through the front access opening. The present invention provides a non-refrigerated air circulating system to remove this cold air from the front of the case and exhaust it to the rear of the case. This system includes an intake chamber 60 with openings 61 extending the length of the front of the case. A second chamber 62 extends along the rear of the case and may either have openings 63 to exhaust the air to the rear of the case or have openings 64 to exhaust the air at the side of the case, as desired. A baffle 64 separates the chambers 60 and 62 and a fan 66 provides circulation of the air by providing air pressure in the chamber 60 at below ambient pressure and pressure in the chamber 62 at above ambient pressure.

It may thus be seen that the present invention provides a refrigerated case having unimpeded access from the front thereof and either unimpeded or movable closure access from the rear thereof with an air curtain across the unimpeded access opening and return air ducts adjacent the access from the rear of the case. This case also provides a horizontal air curtain dividing the case into two vertically adjacent refrigerated zones, the lower of which may be maintained below freezing, while the upper is maintained at above freezing.

The present invention also provides a means for removing the cold air which spills over into the area outside the case, below the unimpeded access opening.

Having thus described the preferred embodiment of the present invention, it will, of course, be understood that various changes may be made in the form, details, arrangement and proportions of the parts without departing from the scope of the invention which consists of the matter shown and described herein and set forth in the appended claims.

I claim:

1. A refrigerated case of the type having an access opening in the front thereof for unimpeded access to material refrigerated within said case comprising:

means for refrigerating said space,

means for establishing an air curtain directed across said access opening and serving to oppose the passage of ambient air through said access opening into said refrigerated space,

including other means for establishing another air curtain within said refrigerated space and substantially horizontally in a plane extending substantially at right angles to said access opening,

said latter curtain serving to divide said refrigerated space into separate vertically adjacent zones of refrigerated space,

and including movable closure means in the rear of said refrigerated case providing access to said refrigeration space through said movable closure means, and having vertically extending refrigerated air ducts in the rear of said refrigerated case to provide for the vertical movement of refrigerated air outside of said refrigerated space.

2. A refrigerated case of the type having an insulated bottom, a movable section back wall, and an insulated top extending above a refrigerated display space

said display space being open at the front,

means establishing a vertical curtain of refrigerated air adjacent the open front of said display space,

means for establishing a horizontal curtain of refrigerated air adjacent the bottom of said display space,

whereby two vertically adjacent zones of refrigerated space are provided, in which

the cases are arranged in end-to-end relation to provide a continuous extended display space having two vertically displaced horizontal zones of refrigerated space, in which the lower of the two vertically displaced zones is maintained at a lower temperature than the upper of said two zones, and including

vertically extending refrigerated air ducts in the rear of said refrigerated case to provide for the vertical movement of refrigerated air outside of said refrigerated space.

5

3. A refrigerated case of the type having an access opening in the front thereof for unimpeded access to material refrigerated within said case comprising:

means for refrigerating said space,

means for establishing an air curtain directed across said access opening and serving to oppose the passage of ambient air through said access opening into said refrigerated space,

access opening in the rear of said refrigerated case providing access to said refrigerated space through said opening, and including

vertically extending refrigerated air ducts in the rear of said refrigerated case to provide for the vertical movement of refrigerated air outside of said refrigerated space.

4. A refrigerated case of the type having an access opening in the front thereof for unimpeded access to material refrigerated within said case comprising:

means for refrigerating said space,

means for establishing an air curtain directed across said access opening and serving to oppose the passage of ambient air through said access opening into said refrigerated space,

movable closure means in the rear of said refrigerated case providing access to said refrigeration space through said

6

movable closure means, and including vertically extending refrigerated air ducts in the rear of said refrigerated case to provide for the vertical movement of refrigerated air outside of said refrigerated space.

5. A refrigerated case of the type having an access opening in the front thereof for unimpeded access to material refrigerated within said case comprising:

means for refrigerating said space,

means for establishing an air curtain directed across said access opening and serving to oppose the passage of ambient air through said access opening into said refrigerated space, and including

other means for establishing another air curtain within said refrigerated space and directed substantially horizontally in a plane extending substantially at right angles to said access opening,

said latter curtain serving to divide said refrigerated space into separate vertically adjacent zones of refrigerated space, and including

vertically extending refrigerated air ducts in the rear of said refrigerated case to provide for the vertical movement of refrigerated air outside of said refrigerated space.

\* \* \* \* \*

25  
30  
35  
40  
45  
50  
55  
60  
65  
70  
75

UNITED STATES PATENT OFFICE  
CERTIFICATE OF CORRECTION

Patent No. 3,675,440 Dated July 11, 1972

Inventor(s) Fayez F. Ibrahim

It is certified that error appears in the above-identified patent and that said Letters Patent are hereby corrected as shown below:

Abstract: Line 6, "he" should be -- the --

Column 2, line 45, "parts" should be -- ports --

Claim 4, column 6, line 3, "provice" should be -- provide --

Claim 5, column 6, line 17, "provice" should be -- provide --

Signed and sealed this 26th day of December 1972.

(SEAL)  
Attest:

EDWARD M. FLETCHER, JR.  
Attesting Officer

ROBERT GOTTSCHALK  
Commissioner of Patents

UNITED STATES PATENT OFFICE  
CERTIFICATE OF CORRECTION

Patent No. 3,675,440 Dated July 11, 1972

Inventor(s) Fayez F. Ibrahim

It is certified that error appears in the above-identified patent and that said Letters Patent are hereby corrected as shown below:

On the Title Page, after Attorney:, it should read

-- Kenneth C. Witt, John C. Wiessler, Robert H. Johnson and Lewis J. Lamm --  
rather than "Kenneth C. Witt, John C. Wiessler, Robert H. Johnson and Lewis  
Buchanan"

Signed and sealed this 1st day of May 1973.

(SEAL)  
Attest:

EDWARD M. FLETCHER, JR.  
Attesting Officer

ROBERT GOTTSCHALK  
Commissioner of Patents