

Jan. 30, 1962

H. RUTZ ETAL
AIR SUCTION SYSTEM FOR REMOVING THREADS, FLY AND
DUST FROM SPINNING MACHINES
Filed Sept. 19, 1960

3,018,603

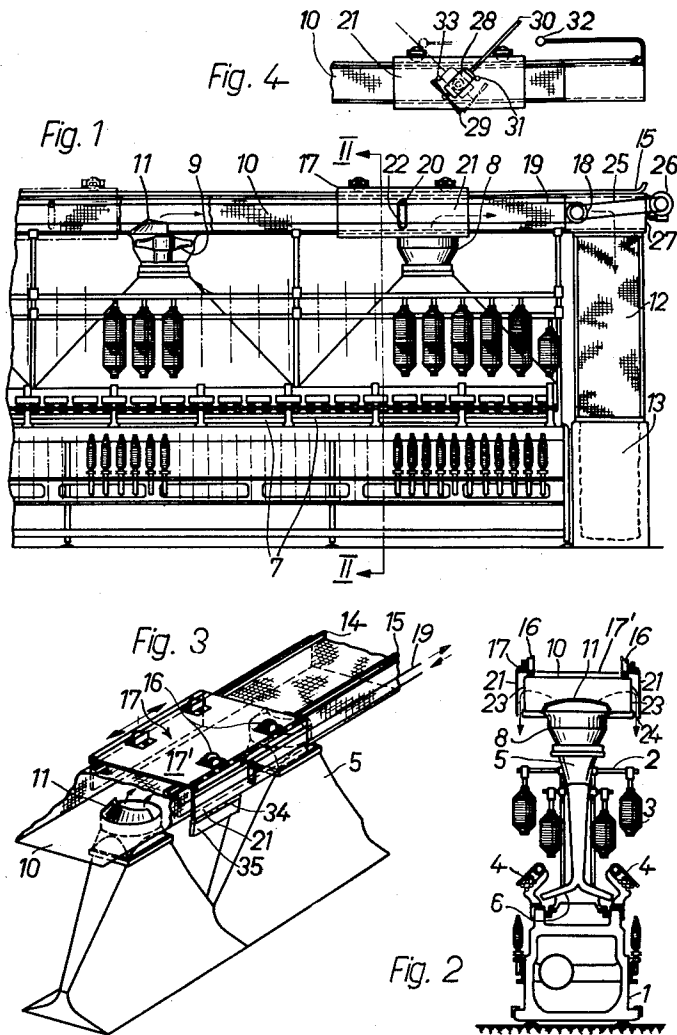

INVENTOR.
HANS RUTZ
RUDOLF HUBER
BY
K. A. Mays
ATTORNEY.

3,018,603

**AIR SUCTION SYSTEM FOR REMOVING
THREADS, FLY AND DUST FROM SPIN-
NING MACHINES**

Hans Rutz and Rudolf Huber, Winterthur, Switzerland,
assignors to Actiengesellschaft Joh. Jacob Rieter &
Cie., Winterthur, Switzerland, a corporation of Swit-
zerland

Filed Sept. 19, 1960, Ser. No. 56,897

Claims priority, application Switzerland Sept. 25, 1959
7 Claims. (Cl. 57-56)

The present invention relates to an air suction system for removing threads fly and dust from spinning machines.

Thread and fly suction devices for spinning machines are known which include vertical suction ducts extending along the longitudinal center plane of the machine and having air inlets adjacent to the drafting arrangements. These ducts taper in the upward direction and are provided with suction fans placed in the upper portions of the ducts for producing an upwardly directed air current. A netting acting as a filter is placed across the outlet on top of the ducts. The netting must be periodically removed for cleaning which involves additional time-consuming work.

It is an object of the present invention to provide a pneumatic thread and dust removing system for spinning machines which is self-cleaning and does not require periodic removal of filters and the like. The system according to the invention includes a plurality of vertical ducts placed along the center line of the spinning machine and having inlets adjacent to the drafting arrangements. The cross section of the vertical ducts becomes smaller in the upward direction and the outlets of the vertical ducts are connected to a horizontal duct placed on top of the spinning machine and extending in the longitudinal direction thereof. A suction fan is provided in each vertical duct adjacent to the horizontal duct for drawing air from the inlet of the respective vertical duct through the vertical duct and discharging the air into the horizontal duct on top of the spinning machine.

At the junctions of the vertical ducts and the horizontal duct means are provided for diverting the air discharged by the suction fans into the horizontal duct to cause the air discharged by all fans to move in the same direction in the duct.

The horizontal duct has perforated wall portions permitting escape of air from the inside of the horizontal duct to the outside but retaining pieces of thread fly lint and dust within the horizontal duct. The retained material has a tendency to stick to the inside of the perforated wall portions of the horizontal duct. In order to temporarily periodically impede or stop the flow of air from the inside of the horizontal duct through the perforated wall portions to the outside a carriage is moved along the horizontal duct which carriage has platelike means covering the perforated wall portions as the carriage moves along the horizontal duct. This impedes flow of air through the perforated wall portions so that the matter retained by the perforated wall portions is not pressed thereonto by the escaping air but is moved along with the air current which flows in the longitudinal direction of the horizontal duct. Since no air can escape through the parts of the perforated wall portions of the horizontal duct which are covered by the carriage more air flows along these parts inside the longitudinal duct and longitudinally thereof so that the air velocity is increased producing a scraping effect of the air current on the inside of the perforated wall portions whereby removal of dust and the like therefrom is assisted. The platelike means forming part of the carriage may be slightly spaced from the perforated wall portions so that some air can

escape therethrough and the platelike means may be so shaped as to direct the air escaping through the perforated wall portions downwards and on to the spinning machine for removing dust therefrom. This dust-laden air is then drawn in through the inlets of the upright portions of the duct system. The platelike means associated with the carriage may include hinged flaps for adjusting the effective area of the platelike means and also the air guide effect of said means.

The novel features which are considered characteristic of the invention are set forth with particularity in the appended claims. The invention itself however and additional objects and advantages thereof will best be understood from the following description of embodiments thereof when read in connection with the accompanying drawing wherein:

FIG. 1 is a lateral elevation of a portion of a spinning machine equipped according to the invention.

FIG. 2 is a cross sectional elevation of the spinning machine shown in FIG. 1 the section being made along line II-II of said figure.

FIG. 3 is a perspective view of a portion of the duct and self-cleaning system according to the invention.

FIG. 4 is a side elevation of a carriage forming part of the system according to the invention the carriage being equipped with modified propelling means.

Referring more particularly to the drawing, numeral 1 designates a frame on which a creel 2 is mounted in the conventional manner, the creel supporting a plurality of vertical skewers for holding roving bobbins 3 grouped on either side of the machine and supplying spinning material to drafting arrangement 4. Suction duct means are placed along the longitudinal center plane of the spinning machine. These duct means have laterally extending inlet portions 6 provided with inlet slots 7 which are below the drafting arrangements 4 and extend longitudinally of the machine. The suction duct means have upright portions 5 which are tapered in the upward direction and longitudinally of the machine. On top of each upright portion a housing 8 containing a suction fan 9 is provided for drawing air into the duct system through the inlets 7 and discharging the air in upward direction. The tops of the housings 8 are connected for air flow to the bottom of a duct 10 extending longitudinally of the machine and having a substantially rectangular cross sectional configuration. The lateral walls and the top wall of the duct 10 are perforated to form a strainer through which the air discharged by the fans 9 moves to the outside of the duct 10. Since the perforated wall portions of the duct 10 are very large compared with the rate of flow of the air through the duct and through the perforations, the air enters the spinning room at a low velocity so that pieces of thread, fly, lint and dust will be retained by the perforated wall portions inside the duct 10. Diverting plates or baffles 11 are provided at the junctions of the blower housings 8 and the duct 10 for diverting the air leaving the housings 8 and matter carried along by the air into the longitudinal direction of the duct 10 so that the air moves from the left end to the right end of the spinning machine shown in FIG. 1. The right end of the longitudinal duct 10 terminates in a vertical duct 12 which is also provided with perforated walls. The vertical duct 12 terminates in a container 13 placed on the floor of the spinning room and receiving matter carried along by the air. The container 13 is preferably made removable and interchangeable.

As seen in FIGS. 1 to 3, rails 14 and 15 are provided on top and longitudinally of the duct 10. These rails support running wheels 16 of a carriage 17 which can be pulled along the duct 10 by means of an endless rope 19 laid around pulleys 18 at the ends of the spinning machine, only one pulley 18 being shown in FIG. 1. A dog 20,

3

movable in a vertical slot 22 in a vertical lateral wall member 21 of the carriage 17, is connected to the rope 19. One of the pulleys 18 is driven by a belt 25 driven by a motor 26 mounted to the end wall 27 of the longitudinal duct 10. In the position shown in FIG. 1 the dogs 20 extend from the upper run of the rope 19. If the latter moves clockwise, the carriages 17 run from left to right in FIG. 1. When a dog reaches the pulley 18 it moves clockwise therearound and downward in the respective slot 22 to the lower run, causing movement of the carriage to the left in FIG. 1. The opposite happens at the left end of the machine which end is not shown.

As seen in FIG. 2, the carriage 17 is provided with plate-like vertical lateral members 21 which are adapted to cover portions of the perforated lateral walls 23 of the longitudinal duct 10, a slight clearance 24 being provided between the members 21 and the lateral walls 23 of the duct 10. A similar clearance is provided between the top wall of the duct 10 and a covering plate 17' (FIG. 3) provided on top of the carriage 17. The length of the latter corresponds approximately to the spacing between two fan housings 8.

FIG. 4 illustrates a modified propelling system for the carriage 17 which omits ropes and belts. A propelling unit including an electric motor 28 driving an air propeller 29 is provided on either side of the carriage and is swingable on a horizontal axis which is normal to the propeller shaft and to the longitudinal axis of the duct 10. Abutments 31 and 33 extend from the lateral plates 21 supported by the carriage 17, limiting the rocking movement of the units 28, 29. In the position of the units shown in FIG. 4, the air propellers 29 move the carriage from the left to the right. When the carriage has reached the extreme right position, rods 30 extending from the units 28, 29 abut against a stationary abutment 32 so that the units 28, 29 are swung in counterclockwise direction until they abut against the abutments 33. In the new position, the units propel the carriage from right to left in FIG. 4 until the rods 30 meet an abutment corresponding to the abutment 32 at the left end of the machine, which is not shown. In the modification shown in FIG. 4 the rails 14 and 15 are preferably used as electric conductors for supplying current to the motors 28. The rails 14 and 15 must therefore be insulated from the duct 10.

As seen in FIG. 3, the lateral plates 21 forming part of the carriage 17 are provided with flaps 35 which are connected to the plates 21 by means of self-locking hinges 34 so that air can be directed onto the bobbins 3 to most efficiently blow undesired matter therefrom.

The system according to the invention operates as follows:

The air discharged by the fans 9 passes through the perforated wall portions of the longitudinal duct 10 to the outside of the duct. Impurities, such as pieces of threads, fly and dust, are retained on the inside of the perforated wall portions and form a filter retaining fine dust. Matter which does not settle on the inside of the perforated wall portions is moved along through the duct 10 by the air current directed by the diverting plates or baffles 11 and is finally deposited in the container 13. The fly and dust settled on the inside of the perforated wall portions of the duct 10 must be periodically removed. This is done by moving the carriage 17 along the duct 10 and thereby temporarily covering the outside of the perforated wall portions. Passage of air through the perforated wall portions is thereby impeded or even completely stopped so that the matter adhering to the inside of the perforated wall portions is not pressed thereonto

4

while the carriage passes by. Since passage of the carriage impedes or prevents escape of air to the outside of the duct 10, the velocity of the air moving inside the duct is increased and the more rapidly flowing air takes along the dust adhering to but not pressed against the inside of the perforated wall portions and carries it through the duct 12 to the collecting container 13.

We claim:

1. In an oblong spinning machine, air suction duct means having inlets extending longitudinally of the machine and upright portions, a horizontal duct extending longitudinally of the machine, said upright portions terminating in said horizontal duct, suction fans individually placed in said upright portions for drawing air through said inlets into said upright portions and delivering the air into said horizontal duct, the latter having perforated wall portions permitting air to escape to the outside of the horizontal duct and retaining threads, fly and dust within said horizontal duct, a carriage movably supported by said horizontal duct to move lengthwise of said horizontal duct, said carriage including means covering said perforated wall portions for impeding flow of air therethrough, and means operatively connected to said carriage for moving said carriage along said duct for periodically interrupting pressing of fly and dust to the inside of said perforated wall portions by the air escaping to the outside of the horizontal duct and promoting flow of air and of fly and dust inside said horizontal duct.

2. In a spinning machine as defined in claim 1, guide means placed in said horizontal duct at the junctions of the latter and said upright duct portions for unidirectionally diverting the air leaving said upright portions into the direction of the longitudinal extension of said horizontal duct.

3. In a spinning machine as defined in claim 2, a fly and dust accumulating receptacle connected to the end of said horizontal duct towards which end the air flows in said horizontal duct.

4. In a spinning machine as defined in claim 1 and wherein said horizontal duct is on top of the spinning machine and has a side facing the spinning machine and sides averse from the spinning machine, said perforated wall portions being on the sides of said horizontal duct averse from the spinning machine.

5. In a spinning machine as defined in claim 1 and wherein said horizontal duct is on top of the spinning machine and has a substantially rectangular cross sectional configuration and said perforated wall portions form at least the lateral walls of said horizontal duct.

6. In a spinning machine as defined in claim 1 and wherein said means covering said perforated wall portions include plates slightly spaced from said perforated wall portions, said plates being adapted to permit air to escape through said perforated wall portions and to guide the escaped air towards the spinning machine for blowing fly and dust therefrom.

7. In a spinning machine according to claim 6 wherein said plates include hinged flaps for adjusting the effective area and guide effect of said plates.

References Cited in the file of this patent

UNITED STATES PATENTS

2,720,074	Bühler	Oct. 11, 1955
2,901,881	Byrum	Sept. 1, 1959
2,976,668	Reiterer	Mar. 28, 1961