

(19) World Intellectual Property
Organization
International Bureau



(43) International Publication Date
15 January 2004 (15.01.2004)

PCT

(10) International Publication Number
WO 2004/004601 A2

- (51) International Patent Classification⁷: **A61F 2/00**
- (21) International Application Number: PCT/US2003/022330
- (22) International Filing Date: 8 July 2003 (08.07.2003)
- (25) Filing Language: English
- (26) Publication Language: English
- (30) Priority Data:
60/394,804 8 July 2002 (08.07.2002) US
- (71) Applicant (for all designated States except US): **ÖSSUR ENGINEERING, INC.** [US/US]; 910 Burstein Drive, Albion, MI 49224 (US).
- (72) Inventors; and
- (75) Inventors/Applicants (for US only): **JANUSSON, Hilmar, Br.** [—/IS]; Valhusabraut 33, IS-170 Seltjarnarnes (IS). **THORSTEINSSON, Freygardur** [—/IS]; Fjardaras 18, IS-110 Reykjavik (IS). **KARASON, Gudjon, G.** [—/SE]; Ryavägen 146, S-191 63 Sollentuna (SE).
- (74) Agent: **DELANEY, Karoline, A.**; Knobbe, Martens, Olson & Bear, LLP, 2040 Main Street, 14th Floor, Irvine, CA 92614 (US).
- (81) Designated States (national): AE, AG, AL, AM, AT, AU, AZ, BA, BB, BG, BR, BY, BZ, CA, CH, CN, CO, CR, CU, CZ (utility model), CZ, DE (utility model), DE, DK (utility model), DK, DM, DZ, EC, EE (utility model), EE, ES, FI (utility model), FI, GB, GD, GE, GH, GM, HR, HU, ID, IL, IN, IS, JP, KE, KG, KP, KR, KZ, LC, LK, LR, LS, LT, LU, LV, MA, MD, MG, MK, MN, MW, MX, MZ, NI, NO, NZ, OM, PG, PH, PL, PT, RO, RU, SC, SD, SE, SG, SK (utility model), SK, SL, SY, TJ, TM, TN, TR, TT, TZ, UA, UG, US, UZ, VC, VN, YU, ZA, ZM, ZW.
- (84) Designated States (regional): ARIPO patent (GH, GM, KE, LS, MW, MZ, SD, SL, SZ, TZ, UG, ZM, ZW), Eurasian patent (AM, AZ, BY, KG, KZ, MD, RU, TJ, TM),

[Continued on next page]

(54) Title: SOCKET LINER INCORPORATING SENSORS TO MONITOR AMPUTEE PROGRESS

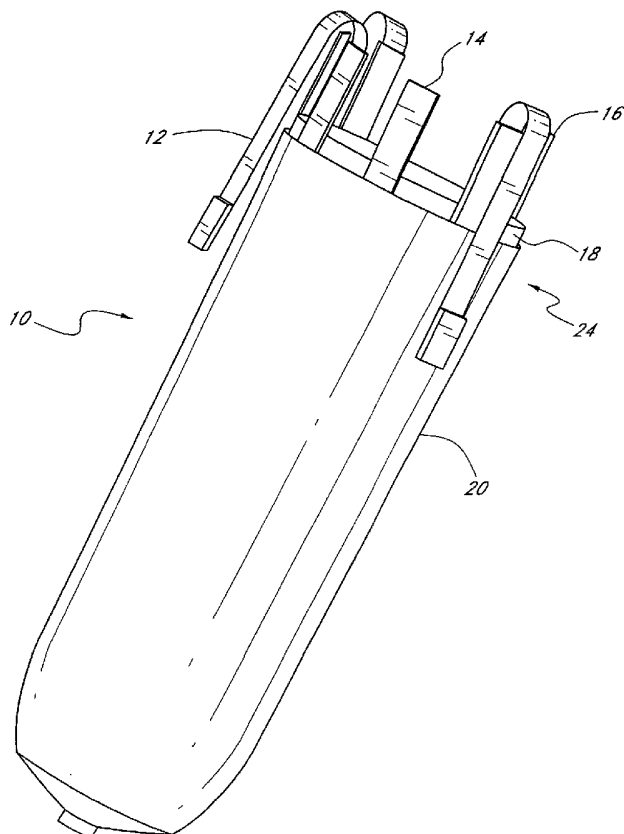

(57) Abstract: Disclosed is a device and method to aid in the monitoring of the health of an amputee's limb. The device employs a socket preferably including a liner. The liner may be constructed of an inner layer and an outer layer. The inner layer is configured to hold a plurality of sensors able to monitor the physiological health of the enclosed limb. The inner layer further employs a transmission device able to receive data from the sensors and send such data to an end user; the end user being a computer, the amputee, or a doctor. Through receipt of such data, the end user is aided in monitoring the health of the limb.

WO 2004/004601 A2



European patent (AT, BE, BG, CH, CY, CZ, DE, DK, EE, ES, FI, FR, GB, GR, HU, IE, IT, LU, MC, NL, PT, RO, SE, SI, SK, TR), OAPI patent (BF, BJ, CF, CG, CI, CM, GA, GN, GQ, GW, ML, MR, NE, SN, TD, TG).

Published:

— *without international search report and to be republished upon receipt of that report*

Declaration under Rule 4.17:

— *of inventorship (Rule 4.17(iv)) for US only*

For two-letter codes and other abbreviations, refer to the "Guidance Notes on Codes and Abbreviations" appearing at the beginning of each regular issue of the PCT Gazette.

SOCKET LINER INCORPORATING SENSORS TO MONITOR AMPUTEE PROGRESS

Background of the Invention

5 Field of the Invention

The field relates generally to a device and method for monitoring of the health of a person's limbs. More specifically, some embodiments relate to the analysis of data affecting the health of an amputee's limb. Some embodiments are targeted towards monitoring a limb through the use of a socket liner.

Description of the Related Art

10 Through the use of ever improving technology, amputees are finding more ways to function through the use of prosthetic devices. Often an amputee uses a socket placed over a limb which is thereby attached to the prosthetic device. The prosthesis may function as a leg, arm, foot, or hand for the amputee.

Use of sockets, however, may cause irritation, volumetric shrinkage and other adverse reactions to the user. Often liners, socks, sleeves, and other limb coverings are used to aid in the prevention of injury to
15 the limb while the socket is in place. Damage to the limb may still occur despite the protection that a liner may provide.

There exists a need for new devices and methods that provide additional functionality to an amputee who uses a socket.

Summary of the Invention

20 Briefly stated, embodiments of the present invention provide a device and method that allows an amputee or a person such as a doctor or prosthetist to monitor various characteristics of a limb. More specifically, the monitoring occurs when the limb is covered by a garment such as a socket or other item having a receiving portion adapted to receive the limb. Preferably, the limb is covered with a socket liner. Optionally the liner may be of a single or multiple layer construction. The liner is configured to hold sensors
25 such as physiological sensors adapted to receive data from the limb throughout the day. The sensors may be constructed to receive a variety of physiological traits from the limb. Preferably, the liner further comprises a transmitter configured to receive data from the sensors and transmit such data to a computer, a user, a doctor or a prosthetist. The receiver of the data is thereby aided in monitoring the health of the enclosed limb.

Accordingly, in one embodiment, a socket is provided for receiving a limb of an amputee. The
30 socket comprises a liner adapted to receive a limb of an amputee, and one or more sensors provided in the liner, the sensors being adapted to monitor physiological data received therein. In one embodiment the liner includes a plurality of grooves for receiving the sensors. The sensors in one embodiment are strips provided along a surface of the liner. In other embodiments, the sensors may be composed of various shapes and sizes. For example, ring-like sensors could be placed around or within the liner. Also, smaller sensors could

be placed at discreet locations along the length of the liner. These smaller sensors may be composed of circular or other geometric shapes. In one embodiment the liner is made from two parts adhered together.

One embodiment of a socket liner includes a liner and one or more sensors provided in the liner adapted to monitor data. One liner includes an inner layer, an outer layer, and a sensor in a channel used to monitor physiological characteristics of a limb. Another liner holds a physiological sensor for receiving data from a limb and transmitter for sending the data to a receiver. Another embodiment discloses a garment with a receiving portion to hold a plurality of sensors wherein the garment is configured to transmit received data to an end user. Also provided is a method of monitoring the physiological characteristics of a limb by using data accumulated from a liner having one physiological sensor located therein.

10

Brief Summary of the Drawings

Figure 1 depicts an assembled embodiment of a two-layered socket liner.

Figure 2 shows an inner liner with a pressure sensor wrapping over its bottom layer.

Figure 3 depicts an alternative view of the inner liner of Figure 2.

Figure 4 shows an embodiment of an inner layer of a socket liner having an oxygen sensor and pressure sensors.

15

Figure 5 depicts an alternative view of the socket liner of Figure 4.

Figure 6 is a side view of a two-layered liner.

Figure 6a is a top end view of the liner of Figure 6.

Figure 7 is a side view of an inner layer with sensors.

20

Figure 8 is a cross-sectional view of a two-layered liner.

Figure 9 is an isometric view of an inner layer with pressure sensors.

Detailed Description of the Preferred Embodiments

Preferred embodiments of the present invention are directed to developing an interface for amputees, where physical data for a limb can be gathered over a period of time in normal action. In one embodiment a socket is used as an interface between the limb and a prosthesis. Amputees may use liners to provide suspension and comfort inside of the socket. A liner may be made of silicone or other material and may provide a locking mechanism with the socket. Locking liners incorporate a pin and are relied upon for suspension of the socket. Non-locking liners or cushion liners are generally used for comfort purposes and use belts or other mechanisms to provide suspension of the socket. The term liner is meant to be construed as a broad term and may encompass a sock, a sleeve, an insert or other coverings placed over an amputee's limb. At the same time, liner is meant to be used in its plain and ordinary meaning. In one embodiment, described further below, sensors are incorporated into the socket liner that is placed between the limb and the socket. In alternative embodiments, sensors may be incorporated into a socket sock or in the socket itself. Typically socks provide cushioning for the limb and add volume to the limb that is lost throughout the day.

35

Preferably, sensors are placed in a silicone or other polymer material (e.g., thermoplastic elastomers or polyurethane) that comprise the socket liner. Sensors may include, but are not limited to:

- Oxygen sensors for the measurement and mapping of peripheral oxygen, such as by means of an array of high sensitivity Spo2 sensors;
- 5 • Pressure sensors detecting the fit of the liner and/or socket over the limb;
- Temperature sensors;
- Sensors to measure blood pressure;
- Humidity sensors;
- Sensors to measure glucose;
- 10 • Sensors to measure limb movement within the liner and/or socket throughout the gait;
- Sensors to measure volume fluctuation of the limb throughout the day;
- Sensors to measure body fat;
- Activity monitoring sensors, i.e. how long the prosthesis is worn from day to day and whether there are high periods of activity.
- 15 • Sensors to measure the shear forces exerted on a limb by the liner and/or socket.

It will be appreciated that other sensors may be used in the liner for different applications and for other diagnostic or physiological measurements.

Data obtained by the sensors can be sent to a remote location to a rehabilitation doctor and/or a CPO (Certified Prosthetist/Orthotist) using telecommunications equipment incorporated into or with the liner.

- 20 This approach assists amputees to integrate into the society and maximize the comfort and use of their prosthesis. Another objective is to gather medical information about amputees in a statistical way, thus giving possibilities for better treatment. The sensors may be held in place within the liner through the use of grooves, channels, or pockets. The pockets may have opened or closed ends. Alternatively, a combination of grooves, channels, and pockets may exist. Further, the sensors may extend over the liner. The sensors
- 25 may be made of rigid, soft, or a combination of rigid and soft materials.

Two ways that sensors can be incorporated into a socket liner are integrated sensors, and sensors placed in-between layers of the socket liner. Sensors, however may be placed into socks, socket inserts, the socket itself, as well as other layers of material that may be incorporated into a device placed over an amputee's limb.

- 30 Figure 1 illustrates one embodiment of a socket liner incorporating physiological sensors, more preferably pressure sensors 14, 16 and oxygen sensors 12. The term "physiological sensor" is meant to define a broad term as well as its ordinary meaning. Physiological sensors may be used to measure peripheral oxygen, temperature, humidity, body fat, blood gasses, blood pressure, blood glucose levels, and other related data such as described above. Physiological pressure sensors 14, 16 may be used to monitor
- 35 the pressure exerted by the limb onto the liner which can be used as a measure of a patient's health. The

pressure sensors 14, 16 may also monitor the pressure exerted by the liner 10 and/or socket on the limb. Oxygen sensors 12 may be used to measure peripheral oxygen such as described above.

The liner 10 may comprise a single or multiple layers. Preferably the liner 10 is made in two layers 18, 20. In one embodiment, the inner layer 18 preferably includes up to six longitudinal grooves or channels 22 that the sensors 12, 14, 16 are placed in. Sensors 12, 14, 16 may be placed in one or more of the grooves 22. Once the sensors 12, 14, 16 have been correctly positioned, the outer layer 20 is positioned over the inner layer 18. Next, the inner 18 and outer layers 20 are adhered together. Both parts are preferably made of silicone, although other suitable materials may be used as well.

Figures 2 and 3 illustrate the inner layer 18 of the liner 10 with six pressure sensors 14, 16 provided therein. As shown in greater detail in Figures 6-9, in one embodiment there are provided five short pressure sensors 14, and one long pressure sensor 16. The five short pressure sensors 14 are preferably provided about 45° apart along the circumference of the liner 10, with the one long pressure sensor 16 being positioned 180° opposite the centralmost of the five short sensors 14. In an example where a 300 mm long silicone liner 10 is used, the short sensors 14 are preferably about 260 mm long, and the one long sensor 16 is about 410 mm long, wrapping around the bottom of the inner layer 18 to the opposite side. These lengths provided above refer to the total length of the flexible part of the respective sensor 14, 16. The sensors 14, 16 preferably further include a rigid part 26, located above the upper edge 24 of the liner 10 (as shown in Figs. 6-9). Any portion of the sensors may be constructed of soft or rigid materials. The sensors may be constructed of silicone and other similar polymer materials. In one embodiment the sensors may be made of a metal and foam combination. In the illustrated embodiment, the rigid part 26 is preferably about 30 mm long.

Figures 4 and 5 illustrate the inner layer 18 of the liner provided with an oxygen sensor 12 therein. The oxygen sensor 12 may be positioned in a variety of positions including next to, under or extending over the pressure sensors 14, 16. As illustrated in Figures 4 and 5, an oxygen sensor 12 is provided over a pressure sensor 14, and both the oxygen sensor 12 and pressure sensors 14, 16 extend over the edge 24 of the liner 10. In another embodiment (not shown), the sensors 12, 14, 16 are completely positioned between the inner 18 and outer layers 20 of the liner 10. In another embodiment, the oxygen sensors 12 are incorporated into the liner 10 without being connected to a pressure sensor 14, 16. Alternatively, oxygen sensors 12 may be incorporated into a liner 10, sock, insert, and/or socket in combination with any of the previously mentioned physiological sensors 12, 14, 16 or by themselves. As illustrated in Figure 1, in one embodiment of an assembled liner 10, three oxygen sensors 12 are provided in the liner 10.

It will be appreciated that the number and arrangement of sensors 12, 14, 16 in the liner 10 can be varied. It will also be appreciated that other ways of incorporating the sensors 12, 14, 16 into the liner 10 can be used as well. Furthermore, sensors 12, 14, 16 need not be positioned in the liner 10 and may be positioned in the socket itself. Other variations of the described device are also contemplated. Thus, the scope of this invention is not to be limited to the preferred embodiments described above.

WHAT IS CLAIMED IS:

1. A socket liner for receiving a limb of an amputee, comprising:
a liner adapted to receive a limb of an amputee; and
one or more sensors provided in the liner, the sensors being adapted to monitor data
5 received therein.
2. The socket of Claim 1, wherein the sensors are pressure sensors.
3. The socket of Claim 1, wherein the sensors are oxygen sensors.
4. The socket of Claim 1, wherein the sensors comprise both pressure sensors and oxygen
sensors.
- 10 5. The socket of Claim 1, wherein the liner includes a plurality of grooves for receiving the
sensors.
6. The socket of Claim 1, wherein the liner includes a plurality of pockets for receiving the
sensors.
7. The socket of Claim 1, wherein the sensors are strips provided along a surface of the liner.
- 15 8. The socket of Claim 1, wherein the liner is made from two parts adhered together.
9. The sensor of Claim 7, wherein one sensor wraps around a bottom of the inner layer.
10. A liner for receiving a limb of an amputee comprising:
an inner layer and an outer layer;
the inner layer comprising at least one channel;
20 at least one sensor provided in the at least one channel used to monitor physiological
characteristics of the limb; and
the outer layer configured to cover the inner layer.
11. The liner of Claim 10 wherein the channel is a pocket.
12. The liner of Claim 10 wherein the sensor is an oxygen sensor.
- 25 13. The liner of Claim 10 wherein the sensor is a pressure sensor.
14. The liner of Claim 10 wherein the sensor is a strip.
15. The liner of Claim 14, wherein the sensor wraps around a bottom of the inner layer.
16. A socket liner for receiving a limb of an amputee comprising:
a liner for holding a physiological sensor;
30 a physiological sensor configured to receive data from a limb regarding its physiological
characteristics;
the sensor being in communication with a transmitter;
the transmitter configured to send data to a receiver to allow an end user to analyze the
physiological characteristics of the limb.
- 35 17. The socket of Claim 16 wherein:

- the liner has an inner and an outer layer;
the inner layer is configured to hold the sensor; and
the outer layer serves to provide an interface between the inner layer and the socket.
- 5 18. The socket of Claim 17, wherein the sensor wraps around a bottom of the inner layer.
19. A garment for receiving a limb of an amputee comprising:
a receiving portion adapted to receive the limb and to hold a plurality of sensors;
the sensors adapted to receive physiological data from the limb;
the garment configured to transmit the physiological data to an end user to monitor the
health of the limb.
- 10 20. A method for monitoring the physiological characteristics of a limb comprising:
providing a liner having at least one physiological sensor therein; and
monitoring physiological characteristics of the limb using data accumulated from the sensor.

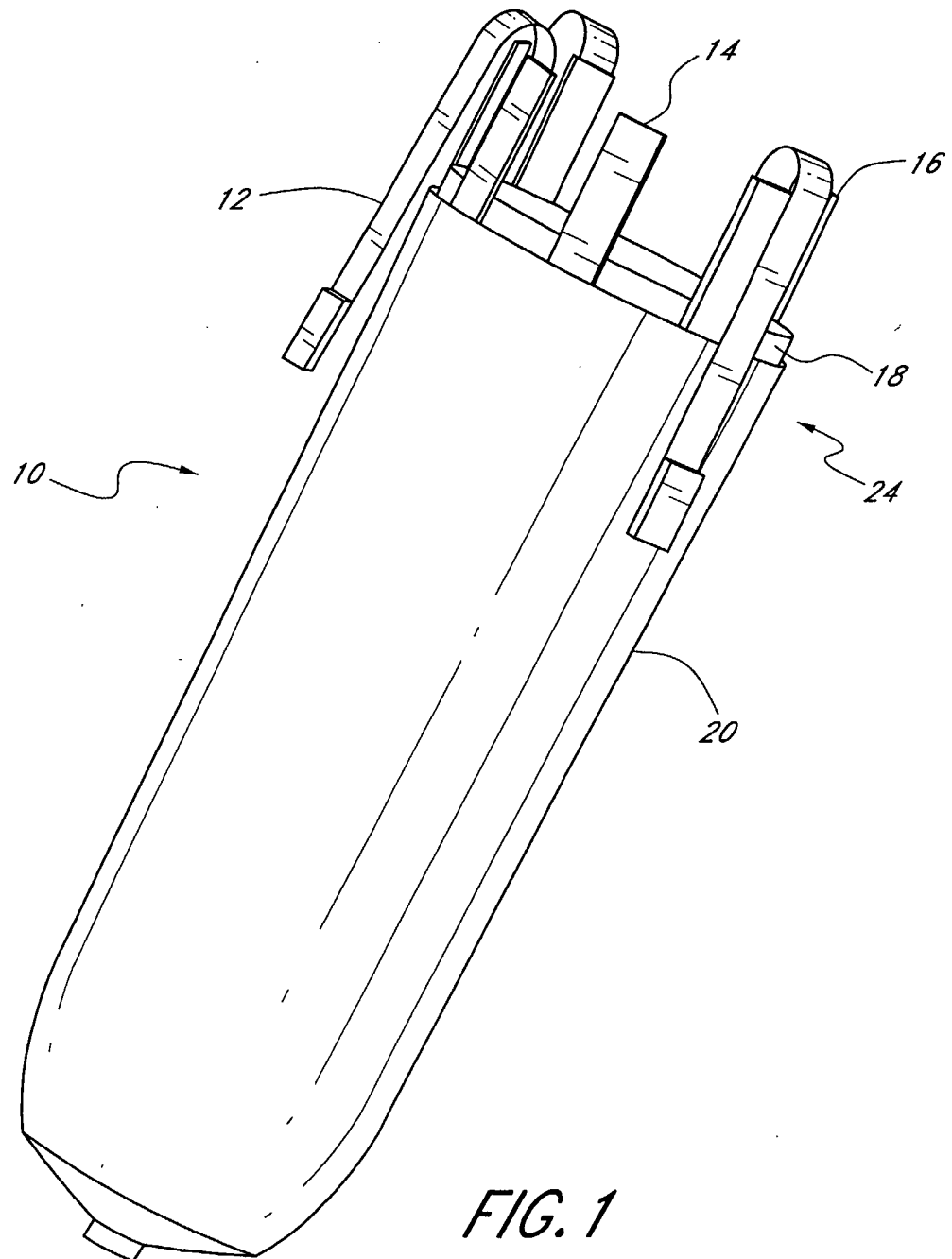

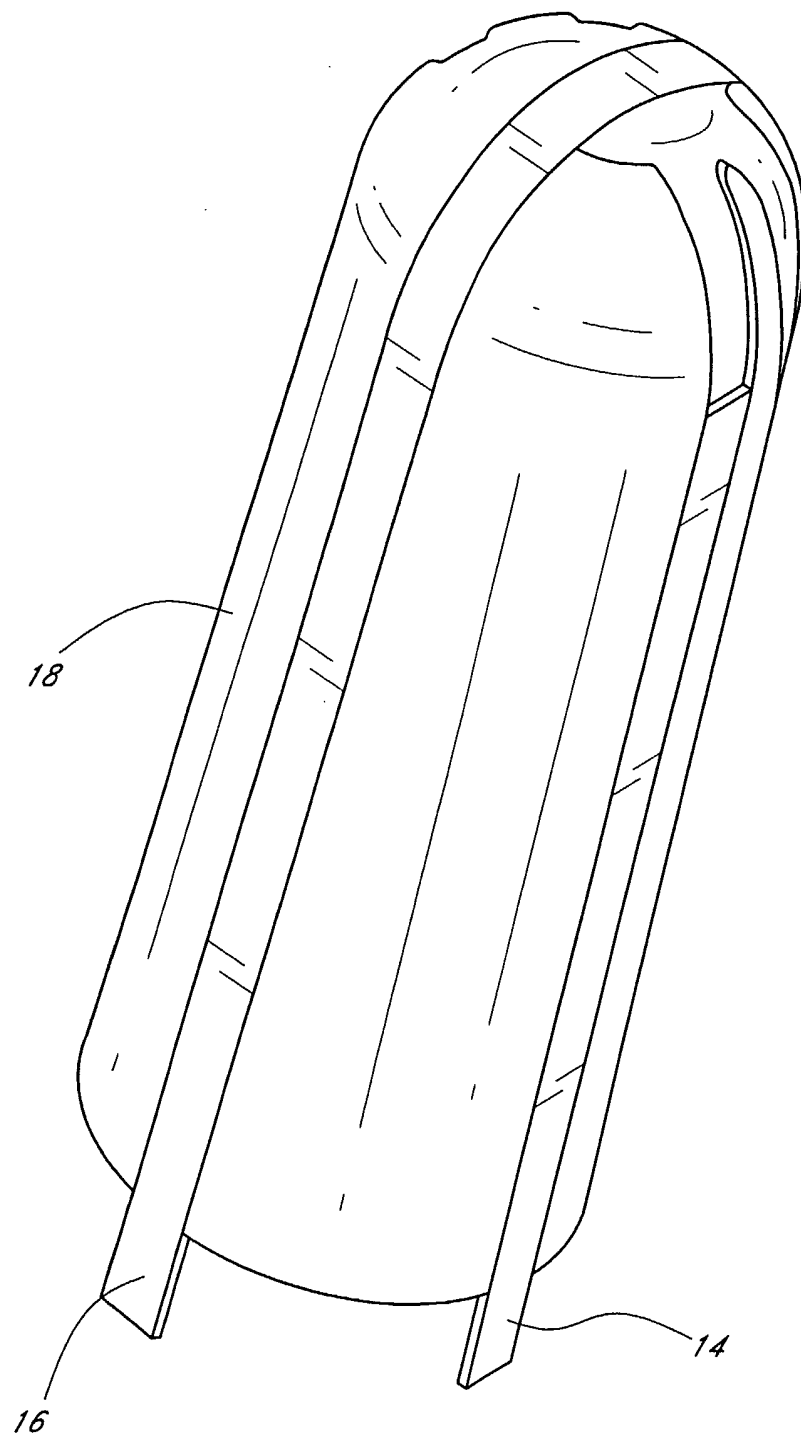
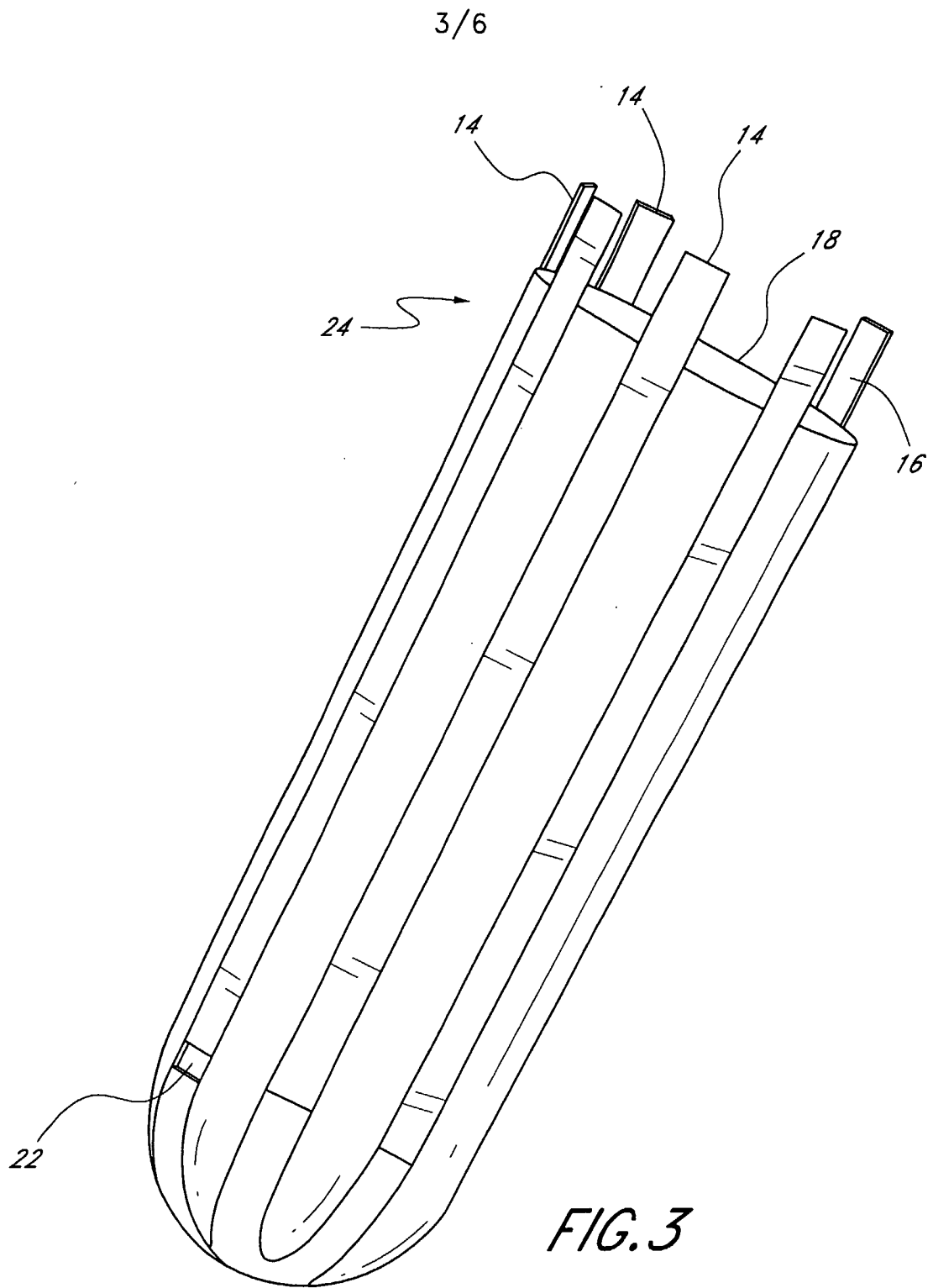

FIG. 2



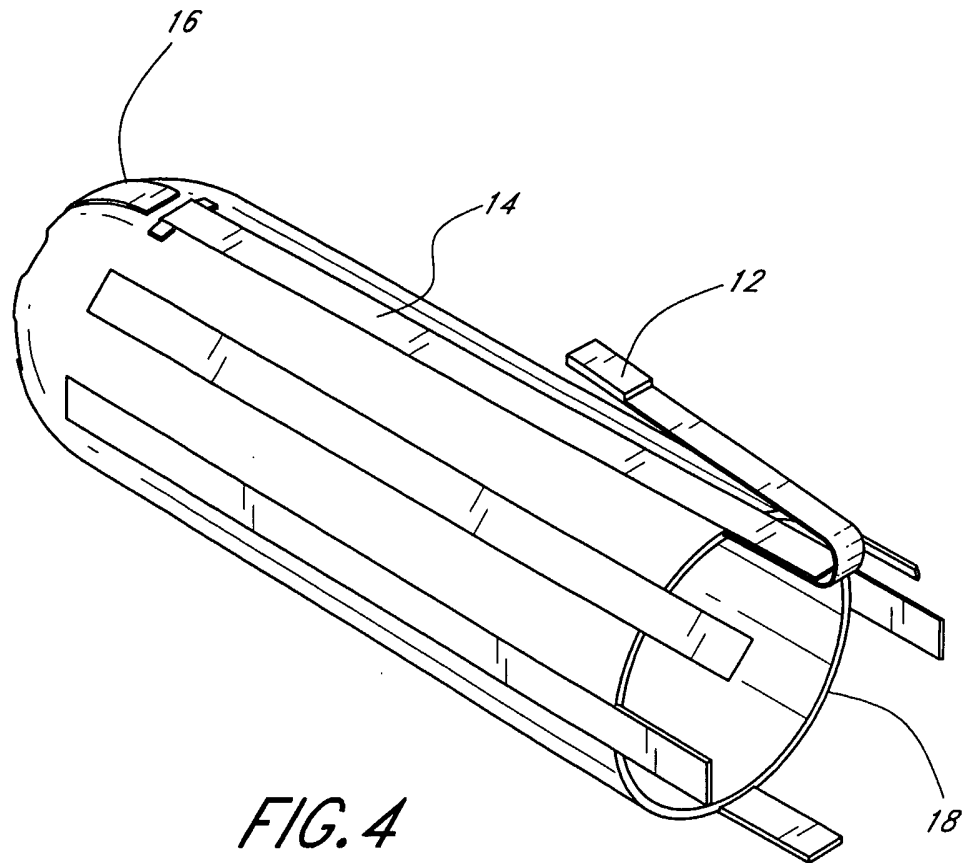
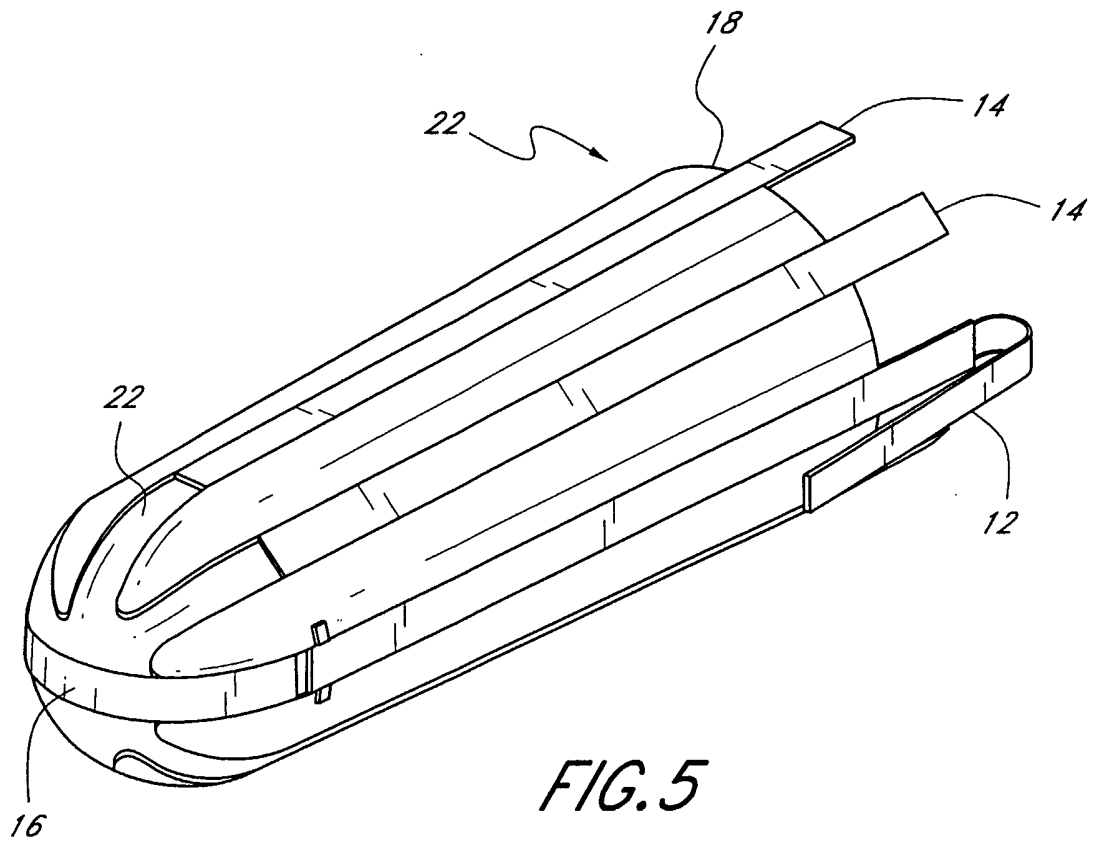

FIG. 4



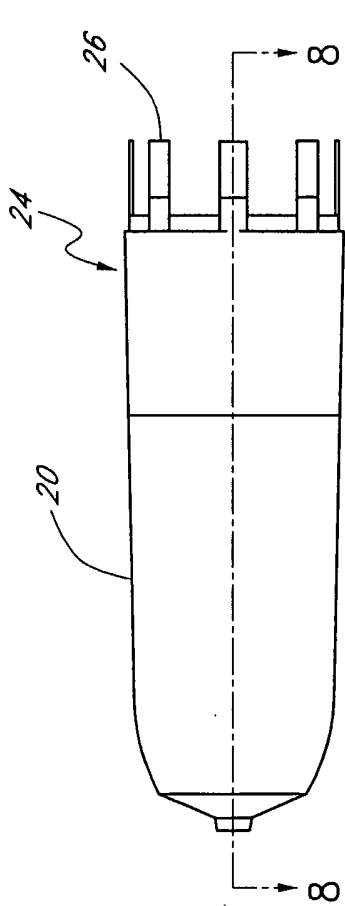

FIG. 6

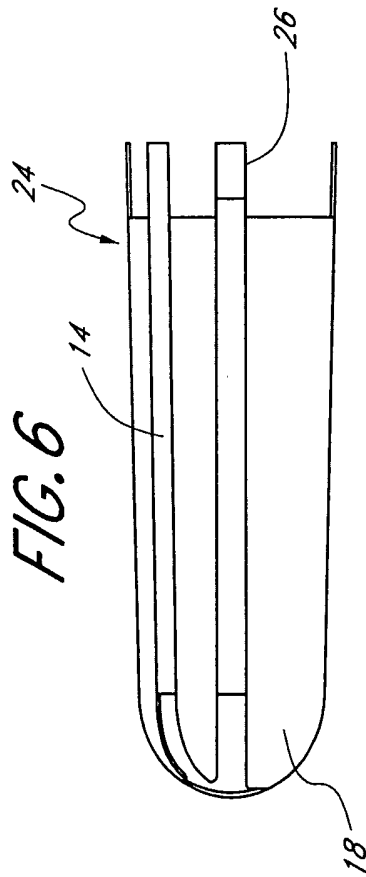

FIG. 7

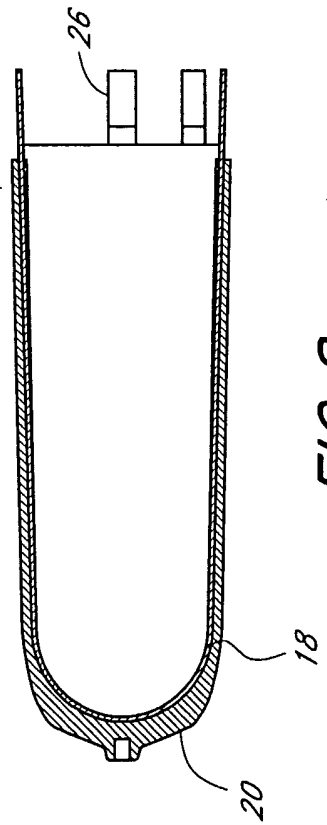

FIG. 8

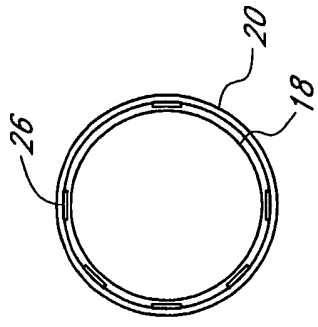

FIG. 6A

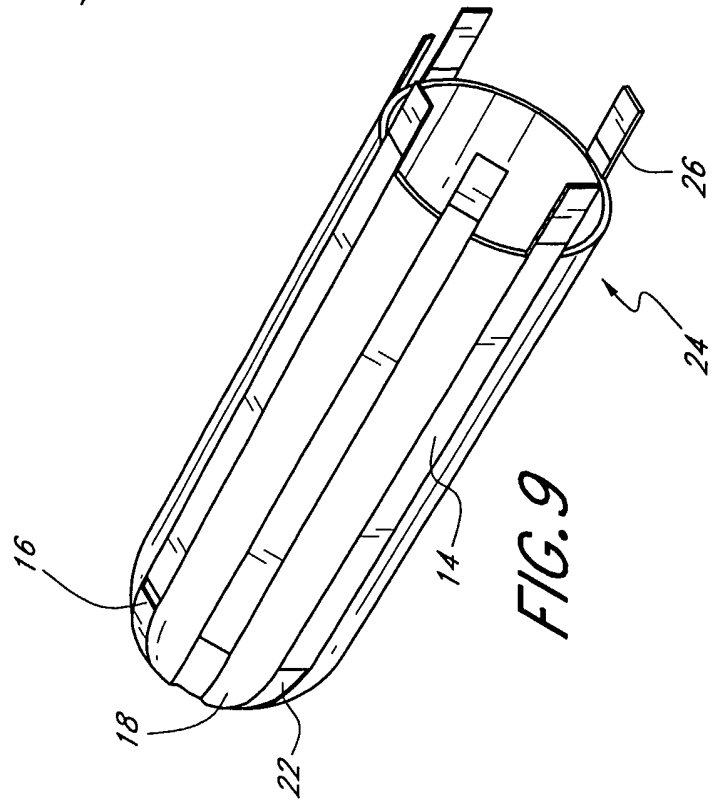

FIG. 9