

(No Model.)

M. D. MARCY.
METHOD OF MANUFACTURING SPINNING RINGS.

No. 523,726.

Patented July 31, 1894.

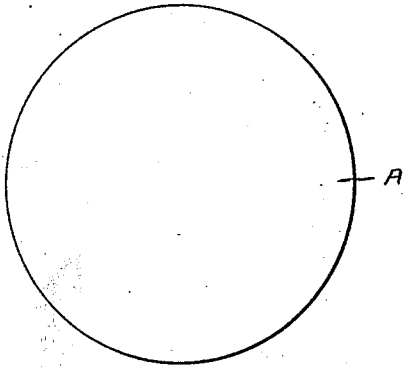

Fig. 1.

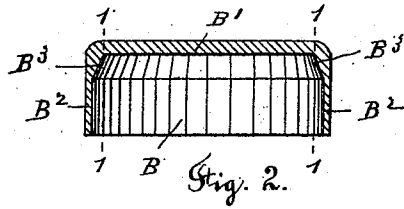

Fig. 2.

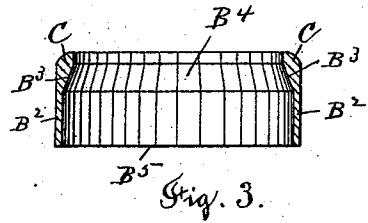

Fig. 3.

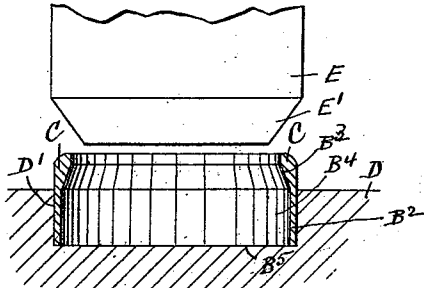

Fig. 4.

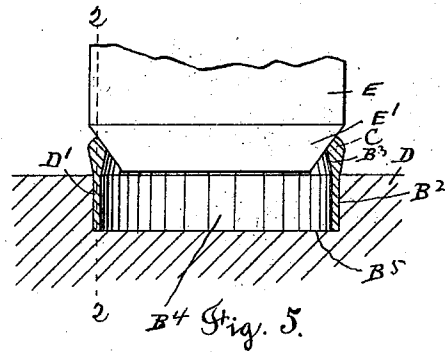

Fig. 5.

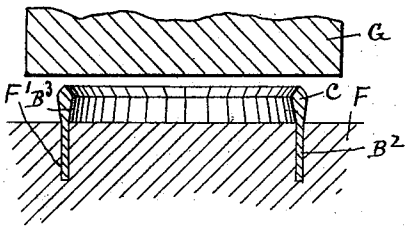

Fig. 6.

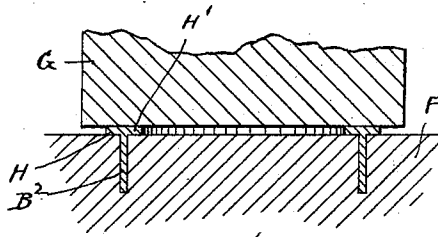

Fig. 7.

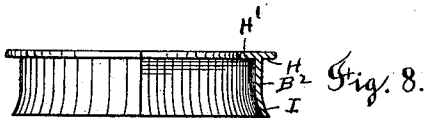

Fig. 8.

Witnesses
A. Whiting
M. D. Marcy.

Inventor
Merrick D. Marcy.
By his Attorney
Rufus D. Fowler.

UNITED STATES PATENT OFFICE.

MERRICK D. MARCY, OF WORCESTER, MASSACHUSETTS.

METHOD OF MANUFACTURING SPINNING-RINGS.

SPECIFICATION forming part of Letters Patent No. 523,726, dated July 31, 1894.

Application filed April 2, 1894. Serial No. 506,005. (No model.)

To all whom it may concern:

Be it known that I, MERRICK D. MARCY, a citizen of the United States, residing at Worcester, in the county of Worcester and State of Massachusetts, have invented a new and useful Improvement in Methods of Manufacturing Spinning-Rings from Sheet Metal, of which the following is a specification, accompanied by drawings representing my improved method of making a spinning-ring from sheet metal and the form of the punch and die by which one of the steps of my improved process is carried into effect, and in which—

15 Figure 1 represents a circular disk of sheet metal from which the ring is made. Fig. 2 represents, in central sectional view, the cup-shaped form into which the disk is drawn by the action of a die press in the usual and well known manner and having the sheet metal forming the sides of the cup reduced in thickness and having a fillet in the corner between the side and bottom of the cup. Fig. 3 represents a ring formed by removing the bottom 25 of the cup, which is shown in Fig. 2; said ring having vertical sides with its upper edge thicker than the sides and having the excess of metal contained in the thick edge overhanging upon the inner side of the ring. Fig. 4 represents a die with the ring, as represented in Fig. 3, held therein and the tapering punch by which the operation of crowding the thick edge of the ring outward is performed; the punch, die and ring being shown 35 in central sectional view. Fig. 5 represents, in central sectional view, the several parts represented in Fig. 4, shown in position when the operation of expanding the thick end of the ring has been accomplished. Fig. 6 represents, in central sectional view, the ring as left by the operation of the punch and die shown in Fig. 5, and the die and punch by which the next operation of upsetting the thick edge of the ring is performed. Fig. 7 45 represents the same parts, as shown in Fig. 6, after the thick edge of the ring has been upset into an internal and external flange suitable to form the track for the traveler and Fig. 8 is a view of the completed ring with 50 one-half of the ring shown in central sectional view.

Similar letters refer to similar parts in the different figures.

My improved method of making a spinning ring from sheet metal is as follows:—A circular blank A, Fig. 1, is cut from sheet metal and drawn by means of appropriate dies into the cup-shaped form represented at B, Fig. 2, in which the bottom B' is of the same thickness as the sheet metal blank A, but the vertical sides B² are reduced in thickness by the action of the punch and die by which the blank is stamped into its cup-shaped form in the usual and well known manner; the punch or male die by which the interior of the cup is formed, being chamfered at its end so as to form a fillet B³ between the bottom B' and the vertical sides B². When the sheet metal blank has been stamped into the cup-shaped form represented in Fig. 2 having the thick bottom B', reduced sides B² and fillet B³, the bottom B' is cut out on the broken lines 1 1, 1 1, Fig. 2, forming a ring-shaped blank B⁴ from which the spinning ring is made.

The operation of cutting the circular blank from sheet metal, stamping it into a cup-shaped blank B⁴ represented in Fig. 3, will be readily understood by those conversant with the art of working sheet metal in a die press and I have not, therefore, described it in detail; my improved method being with an annular blank B⁴, represented in sectional view in Fig. 3, and consisting of a band or ring formed of the sides B² having its edge C thicker than the side B² and made to overhang upon the inside of the ring and the first step in making a spinning ring from an annular blank, as shown in Fig. 3, consists in the expansion of the upper or thick edge C, so as to bring it symmetrical with the vertical walls forming the sides of the ring, that is, with the excess in the thickness of the edge C, overhanging equally upon both the outer and inner sides of the ring, so that a line passing through the center of the side B² and parallel with the axis of the ring will also pass through the center of the thick edge C.

The operation of expanding the end of the ring is accomplished by means of a reciprocating punch E and a die D, such as are represented in sectional view in Fig. 4, the die D having a circular recess D' whose diameter

equals the outer diameter of the annular blank B^1 and whose depth equals the distance from the lower edge B^5 of the annular blank to the lower edge of the fillet B^3 ; the object of the die D being to form a support to the outside of the annular blank at a point just below the plane of the fillet B^3 .

The reciprocating punch E , having its lower end tapering as at E' , is brought down within the thick edge C of the annular blank which projects above the face of the die D , causing the edge C of the annular blank to be expanded or bent outward, as represented in Fig. 5, so that the center line of the side B^2 will be coincident with the center line of the thick edge C , as indicated by the broken line 2, 2, Fig. 5.

The amount of expansion necessary to bring the edge C symmetrical with the sides of the ring is determined by the inclination of the end E' of the punch and the extent of its downward movement. When the thick edge C of the ring has been expanded so the ends of the metal will overhang the sides B^2 equally upon the outer and inner side, the annular blank is then placed within an annular channel or groove F' formed in a die F , the depth of the groove F' being as great as the side B^2 , so that the die F will allow no part of the thin side B^2 to project above the face of the die, which would render the ring liable to buckle when the edge C is upset into the flanged track for the traveler. Pressure is applied to the edge C of the ring in a line parallel with its axis by means of a punch G by which the edge C is compressed, or upset into a flange extending equally upon both sides of the ring and forming the outer flange H

and the inner flange H' . The lower edge of the side B^2 is then expanded, as represented at I , Fig. 8, to form a base for the ring; and the ring is completed by trimming the edges of the flanges H and H' concentrically with the axis of the ring and polishing the flanges to form a suitable track for a ring traveler.

I do not confine myself to the use of an annular blank having its thick edge overhanging upon the inner side, as it may be made to overhang upon the outer side of the ring, neither do I confine myself to the specific form of punch and die as shown.

What I claim as my invention, and desire to secure by Letters Patent, is—

The within described method of forming a spinning ring from sheet metal and consisting (first) in forming an annular blank having sides B^2 and a thick edge C formed by a fillet B^3 overhanging upon the inner side of the blank (second) expanding the thick edge of the annular blank by lateral pressure applied to the inside and without upsetting the same, whereby the thick edge of the blank is brought symmetrical with the side walls of the blank (third) upsetting the thick edge of the blank by a pressure applied parallel with its axis while the vertical walls of said blank are supported by a die provided with an annular channel fitting said walls, whereby the thick edge of the blank is formed into an outer and inner flange adapted to form the track for a ring traveler, substantially as described.

Dated this 31st day of March, 1894.

MERRICK D. MARCY.

Witnesses:

F. M. MARCY,
RUFUS B. FOWLER.