

(No Model.)

I. ELTING.

FASTENER FOR MEETING RAILS OF SASHES.

No. 526,386.

Patented Sept. 25, 1894.

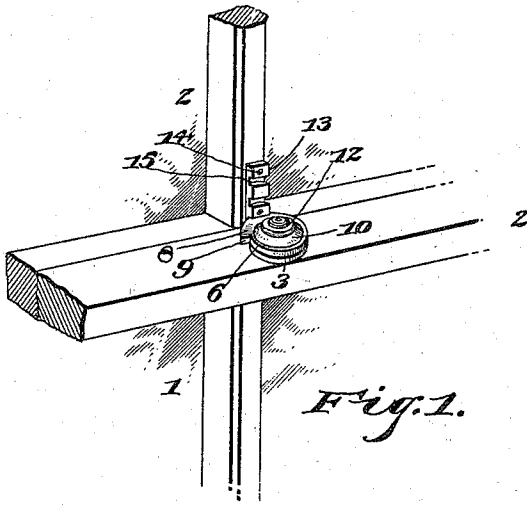

Fig. 1.

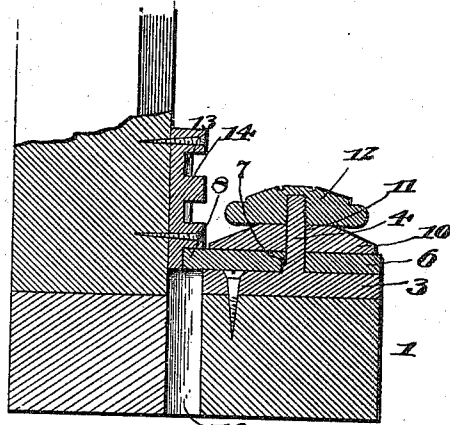

Fig. 2.

Fig. 3.

Fig. 4.

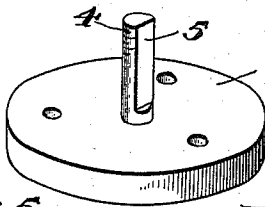

Fig. 5.

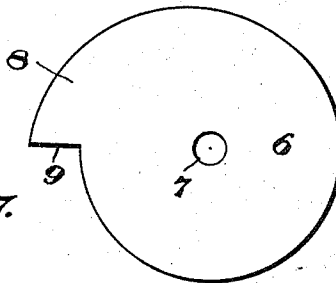

Fig. 6.

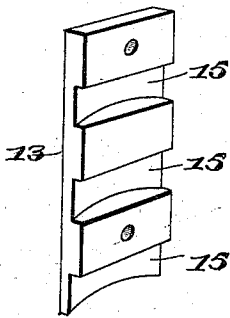
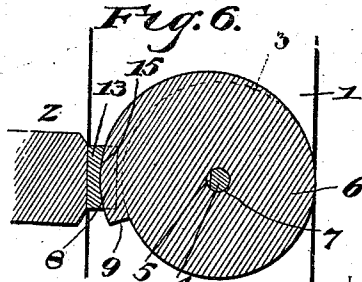
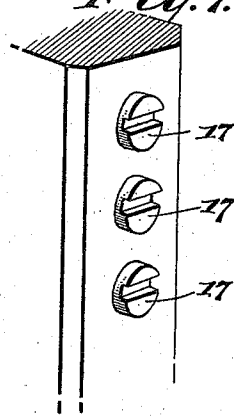

Fig. 7.



Inventor

Irving Elting.

Witnesses

B. S. Ober.

J. A. Owen.

By his Attorneys.

C. Snow & Co.

UNITED STATES PATENT OFFICE.

IRVING ELTING, OF SAUGERTIES, NEW YORK.

FASTENER FOR MEETING-RAILS OF SASHES.

SPECIFICATION forming part of Letters Patent No. 526,386, dated September 25, 1894.

Application filed April 5, 1894. Serial No. 506,494. (No model.)

To all whom it may concern:

Be it known that I, IRVING ELTING, a citizen of the United States, residing at Saugerties, in the county of Ulster and State of New York, have invented a new and useful Sash-Lock, of which the following is a specification.

My invention relates to an improvement in that class of sash-locks wherein a revoluble plate is mounted on one sash and adapted to engage with the companion sash; and the object of this invention is to provide superior means for locking the two sashes at different relative positions, so that the windows may be locked partially open, thus permitting proper ventilation without endangering the security of the window. This end I attain by means of the peculiar features of construction and combination and arrangement of parts, all of which will be more fully described hereinafter and finally embodied in the claims.

In the drawings:—Figure 1 represents a perspective view of my improvements showing their use; Fig. 2, a vertical section of the same; Fig. 3, a detail perspective of the spindle for mounting the locking disk; Fig. 4, a plan view of the locking disk; Fig. 5, a detail perspective of the plate for co-operation with the disk; Fig. 6, a horizontal section; Fig. 7, a modification.

The reference numeral 1 indicates the lower sash, and 2 the upper sash, both of which may be of any construction. Secured to the upper side of the top rail of sash 1 and at the middle thereof is the circular base plate 3, which has formed integral therewith the spindle 4. This spindle is provided with the flattened side 5, and is screw-threaded from a point just above plate 3 to its upper end.

6 indicates the locking disk, which is provided with a central opening 7 adapted to fit over the circular portion of the spindle 4, so as to be capable of free revolution thereon.

The periphery of the disk 6 is formed one half truly circular, while the remaining half, 8, is formed eccentric thereto and with an abrupt shoulder 9 at its greatest diameter. The truly circular portion of the periphery is adapted to lie in vertical alignment with the periphery of plate 3, while the part 8 is designed to project beyond the same and to extend over the sash 2.

Arranged on the spindle 4, and lying flush with disk 6, is the washer 10, which is circular in shape and provided with a central opening 11, said opening being formed with a plane portion, adapted to match with the side 5 of the spindle, whereby the washer is made incapable of rotary movement on the spindle. The disk 6 and washer 10 are held in place by the nut 12, which has a screw-threaded depression in its under side, adapted to receive the upper end of the spindle 4 and to hold the parts in place, as explained. Thus it will be seen that disk 6 may be turned by hand on spindle 4, so as to throw the eccentric periphery 8 in or out of engagement with sash 2. The sash 2 is provided with the vertical plate 13, which is secured thereto by means of the screws 14, and which is provided with the horizontally extending slots 15, preferably three in number, and curved in the arc of a circle, so as to snugly receive the eccentric part 8 of the disk 6. These slots, 15, are of course in vertical alignment.

Formed in the rear or outer edge of the top rail of sash 1, and extending vertically therein, is the groove 16, which is adapted for the passage of plate 13, whereby the two mid-rails of the sashes are allowed close engagement, and a consequent tight joint.

The operation of my invention will be apparent from the foregoing.

To lock the sashes together the disk 6 should be grasped by hand and moved axially so as to place the eccentric portion 8 in engagement with one of the slots 15, thus making independent movement of the sashes impossible, while they may be disengaged by reversing the disk, as will be apparent from Fig. 6 of the drawings.

Owing to the series of slots 15, the sashes may be adjusted at various vertical positions, so as to permit ventilation of the apartments, and yet make the fraudulent entry quite impossible.

The modification of Fig. 7 consists in substituting the plate 13 by the screws 17, which are each provided with enlarged heads and have them slotted so as to take the place of slots 15. This form may be preferred from the cheapness and simplicity and will be well understood from the foregoing.

Having thus described my invention, what I claim as new, and desire to secure by Letters Patent, is—

1. A sash lock consisting of a base plate
5 adapted to be secured to the upper rail of the lower sash and having a spindle arising therefrom, a locking disk revolubly mounted upon the spindle and having one-half of its periphery concentric with the periphery of the base
10 plate, while the remaining portion of the periphery of the locking-disk is eccentric thereto, a washer mounted upon the spindle and concentric to the concentric portion of the locking-disk, means for holding the washer in
15 place and for holding the several parts snugly against each other, and a series of horizontal grooves in the companion sash into which the eccentric portion of the locking disk is adapted to pass, substantially as described.
2. A sash lock consisting of a spindle
20 adapted to be secured to the top rail of the

lower sash and to arise vertically therefrom, said spindle being formed with a plane longitudinal portion extending nearly to the base thereof, a disk revolubly mounted on
25 the spindle and below the plane portion thereof and adapted to move into engagement with the remaining sash, a washer fitting on the spindle and lying against the disk and having a plane portion adapted to match with
30 the plane portion of the spindle and to be prevented from turning thereby, and a nut operating on the spindle so as to hold the disk and washer in place, substantially as described.
35

In testimony that I claim the foregoing as my own I have hereto affixed my signature in the presence of two witnesses.

IRVING ELTING.

Witnesses:

GEO. W. ELTING,
J. P. RUSSELL.