

May 9, 1933.

B. W. BROCKETT

1,908,111

TAIL CLAMP

Filed May 22, 1930

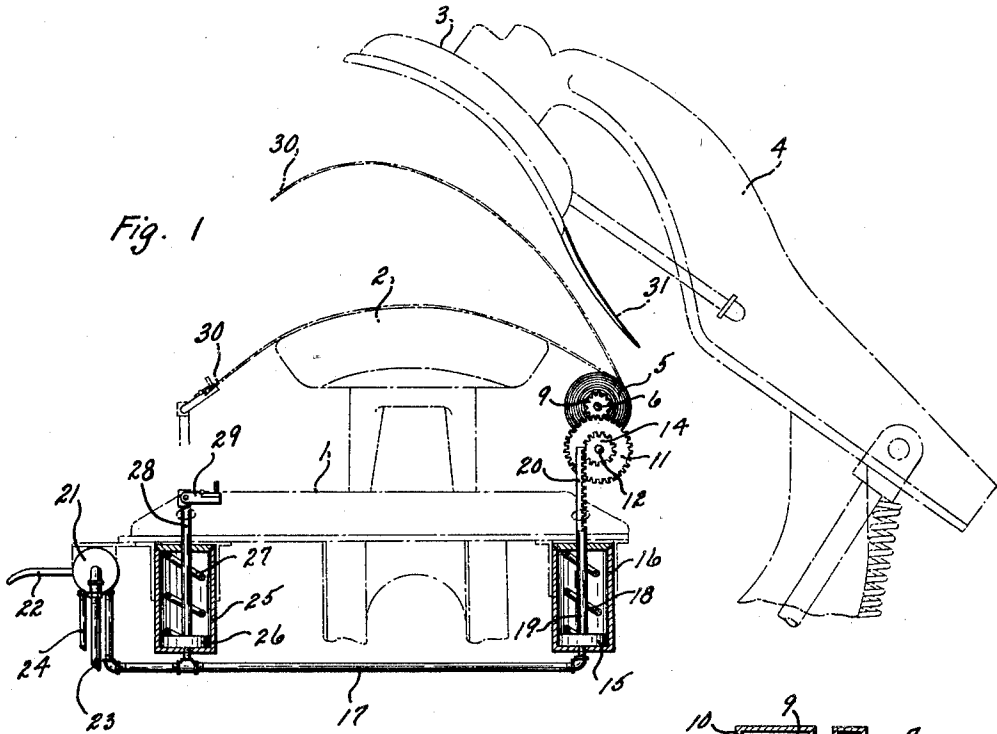

Fig. 1

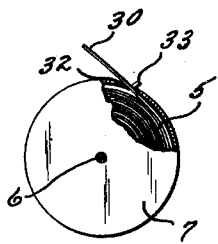

Fig. 3

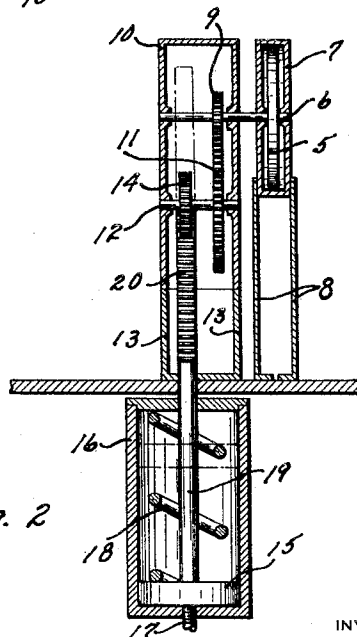

Fig. 2

INVENTOR

Bluford W. Brockett

BY

Brockett, Hyde, Higley & Meyer
ATTORNEYS

UNITED STATES PATENT OFFICE

BLUFORD W. BROCKETT, OF CLEVELAND HEIGHTS, OHIO, ASSIGNOR TO THE AMERICAN LAUNDRY MACHINERY COMPANY, OF NORWOOD, OHIO, A CORPORATION OF OHIO

TAIL CLAMP

Application filed May 22, 1930. Serial No. 454,699.

My invention relates to an attachment for pressing machines and, particularly, to an attachment commonly known as a tail clamp which is adapted to hold the tail of a shirt in such position on the buck of a press that it may be properly pressed and obviate the necessity of use of the operator's hands as a holding means.

Heretofore, there have been numerous different types of tail clamps some of which embodied simply a flexible band secured on one side of the buck and adapted to be drawn over the buck and work thereon and secured to the other side of the buck to hold the work in position. Other types have embodied a swinging carrier frame adapted to be swung to such position as to place the clamping band crosswise of the buck or to such position as to remove the clamping band from the buck.

My invention contemplates the provision of a tail clamp embodying a flexible band that is normally disposed on one side of the buck in the smallest possible space together with mechanism for projecting the flexible band laterally across the buck and the work thereon and then drawing the band downwardly towards the buck with the least possible longitudinal movement of the band to clamp the work on the buck. It also contemplates the provision of means for drawing the band downwardly towards the buck of such nature that the device automatically adjusts itself to work of various thicknesses thereon.

Various objects and advantageous features of my invention will be apparent from the following description and one embodiment thereof may be seen in the accompanying drawing wherein similar characters of reference designate corresponding parts, and wherein:

Fig. 1 is a side view partly in section, of one embodiment of my invention in combination with a part of the pressing machine that is diagrammatically shown; Fig. 2 is a side elevation of the device but showing the device and operating parts as being enclosed in a housing; and Fig. 3 is a view of the tail clamp and tail clamp housing.

Referring to the drawing and particularly Fig. 1 thereof, I have diagrammatically

shown a pressing machine which may be of any ordinary type and which consists of the usual pressing table 1, buck 2, and a pressing head 3 that is mounted on the end of a supporting arm 4 which is pivotally mounted and adapted to be swung by suitable means about its pivot to bring the head 3 into and out of pressing engagement with the buck 2.

In accordance with my invention, I have provided a tail clamping device consisting of a flexible band 5 that is normally disposed in a roll about a shaft or central core 6 journaled in a housing 7, the housing also covering the roll made up of the flexible band 5 and being suitably supported on the table 1 by any well known means and, in this instance, by uprights 8 secured to the table at one of their ends.

The pinion gear 9 is rigidly mounted on the shaft 6 and disposed within a housing 10 in which the shaft 6 is also journaled. This pinion gear meshes with another and larger gear 11 mounted on a shaft 12 that is also journaled in the housing 10, this housing being suitably supported on the table 1, as for instance, by means of the uprights 13. The shaft 12 also carries a gear 14 the purpose of which will be hereinafter apparent.

The operating means for these gears just described embodies a single stroke piston 15 disposed within a cylinder 16 and adapted to be moved in one direction by air pressure admitted to the cylinder through the conduit 17 and in the opposite direction by means of a spring 18 disposed between the upper surface of the piston 15 and the inner surface of the upright end of the cylinder 16.

As shown in Figs. 1 and 2, the piston rod 19 that forms a part of the piston 15 takes the form of a rack 20, it having gear teeth disposed thereon for a portion of its length. This rack 20 is so disposed as to mesh with the gear 14 whereby upward or downward movement of the piston 15 and rack 20 will cause rotation of the gears 9, 11 and 12 and a consequent unwinding or winding up of the flexible band 5 depending on the direction of movement of the piston and rack. It will be understood that the relative size of the gears 9, 11 and 12 may be varied as desired

to change the speed of rotation of the shaft or central bore 6 about which the clamping band is normally disposed in rolled position.

Air pressure is supplied to the cylinder 16 by way of the conduit 17, as hereinbefore stated, which conduit leads from a valve 21 having an operating handle 22 in such position as to be convenient to the operator of the press and embodying an air inlet or supply pipe 23 and an exhaust conduit 24.

Also in accordance with my invention, I have provided a cylinder and piston construction at the opposite side of the buck from the cylinder and piston construction just described and embodying a cylinder 25 and piston 26 that is adapted to be moved in one direction in the cylinder simultaneously with movement of the piston 15 by reason of air pressure being supplied to both cylinders from the same line 17 and in the opposite direction by means of a spring 27 that is disposed between the upper surface of the piston and the under surface of the upper end of the cylinder 25. As shown in Fig. 1, the piston rod 28 which forms a part of the piston 26 projects upwardly through the table 1 and is provided on its upper end with a suitable means 29 that may, as in this instance, take the form of a pivoted arm carrying a pin for engaging with an opening or a single one of a plurality of openings in the outer end 30 of the clamping band 5 and securing the free end of the band. It will be apparent that pistons 15 and 26 will be simultaneously operated since they both receive air pressure from the line 17 which supply of air pressure is controlled by the same valve 21. As also shown in Fig. 1, the lowermost rear edge of the pressing head 3 is provided with a projection or guide 31 that extends rearwardly and provides a guide means for preventing the clamping band 5 from passing upwardly past the rear of the pressing head and ensures that it will pass between the pressing head and the buck when it is projected outwardly from a slot 32 in the housing 7. As shown in Fig. 3, a stop 33 on the clamping band 5 prevents the free end thereof from entering the housing 7.

In the operation of this device, the work to be pressed is first placed upon the buck 2 whereupon the operating handle 22 of the valve 21 is so moved as to supply air pressure from the pipe 23 to the conduit 17 and thereby to the cylinders 25 and 16. Such air pressure will simultaneously move the pistons 15 and 26 upwardly, the upward movement of the piston 15 causing rotation of the gears 9, 11 and 12 in the manner hereinbefore described and rotation of the shaft 6 to cause unwinding of the clamping band 5 out of its normal reeled position whereby it will be projected between the pressing member and buck as shown in Fig. 1 by reason of rotation of the shaft 6 and the normal tendency of

the clamping band to unwind from about the shaft.

Simultaneously with the projecting of the clamping band 5 between the pressing member and buck, the piston 26 will be moving upwardly and projecting the piston rod 28 and securing means 29 upwardly above the table 1 in front of the buck 2.

The clamping band 5 having been projected between the pressing head and the buck and the securing means 29 raised to its desired height the operating handle 22 of the valve 21 may be moved to such position that the air pressure beneath the pistons 15 and 26 may exhaust through the conduit 17, valve 21 and exhaust conduit 24 whereupon the springs 18 and 27 will become effective to simultaneously move the piston rods 19 and 28 downwardly.

Such downward movement of the piston rod 19 will cause rotation of the shaft 6 through the medium of the rack and gear mechanism hereinbefore described and winding up of the clamping band 5 about the shaft. Likewise, downward movement of the piston 26 will cause the securing means 29 to be moved downwardly towards the table 1 and, since the outermost end 30 of the clamping band is secured to the securing means 29, the outer end of the clamping band will be drawn downwardly towards the buck. It will be apparent that such winding up of the clamping band 5 about the shaft 6 and simultaneous downward movement of the outer end 30 of the clamping band will draw the clamping band down against the buck and secure the work thereon.

Referring to the drawing and the preceding description, it will be seen that I have provided a device of the character described embodying numerous novel and advantageous features. For instance, I have provided a clamping band that is normally disposed in an out of the way position at the rear of the pressing buck and so disposed as to take up the smallest amount of space possible, this being due to the fact that the clamping band is normally wound around the shaft 6. Another advantageous feature resides in the fact that I have provided mechanical means which, together with the normal tendency of the clamping band to unwind from roll position, is capable of projecting the clamping band outwardly between the pressing head and the buck to such position that it may be easily grasped by the operator and secured at the opposite side of the buck and across the work thereon whereupon the same mechanical means will be effective to rewind the clamping band into rolled position until it is drawn downwardly across the face of the buck to hold the work thereon.

Still another advantageous feature of my invention resides in the means provided for

securing the outermost end of the clamping band on the opposite side of the buck from that in which it is normally disposed, this means being of such nature that it is in an out
 5 of way position during the time that work is being placed upon the buck but moves upwardly simultaneously with the outward movement of the clamping band across the buck to such position that the outermost end
 10 of the clamping band may be easily secured thereto. A further feature resides in the fact that means have been provided whereby the outermost end of the clamping band will be drawn downwardly after being secured on
 15 the opposite side of the buck and simultaneously with the winding up of the other end thereof whereby the clamping band will be drawn firmly downwardly upon the work on the buck with the least possible longitudinal movement of the clamping band. This
 20 is advantageous in that it prevents wrinkling and distortion of the work upon the buck when the clamping band is drawn down to locking position.

25 What I claim is:

1. In combination with a pressing machine including a support, a pressing buck on said support, and a movable head adapted to cooperate with said buck, a clamping band for holding work on said buck, mechanical means
 30 for projecting said clamping band laterally across said buck, and guide means on said movable head for guiding said clamping band between said buck and said head.

35 2. In combination with a pressing machine including a support, a buck, and a movable head adapted to cooperate with said buck, a clamping band normally disposed in reeled condition about a central core and on one side
 40 of said buck, mechanical means for projecting said clamping band laterally across said buck, and means for securing to the outermost end of said clamping band on the opposite side of said buck, and a guide on the
 45 rearward edge of said movable member adapted to guide the free end of said clamping band between said buck and said movable member.

50 3. In combination with a pressing machine including a pressing bed, a clamping band for holding work on said bed and normally disposed on one side thereof, said clamping band having a free end, means for projecting said
 55 clamping band laterally across said bed, means for securing the free end of said clamping band on the opposite side of said bed, means for drawing the free end of said clamping band downwardly, and means for simultaneously drawing said clamping band laterally
 60 across said bed to thereby move said clamping band into clamping engagement with said bed.

65 4. In combination with a pressing machine including a pressing bed, a clamping band disposed on one side of the bed and normally

in reeled condition about a core, said clamping band having a free end, and means for rotating said core to project the free end of said clamping band laterally across said bed.

5. In combination with a pressing machine including a pressing bed, a clamping band
 70 disposed on one side of the bed and normally in reeled condition about a core, said clamping band having a free end, and means for rotating said core to either project the free
 75 end of said clamping band laterally across said bed or to withdraw said clamping band to its normal reeled condition.

6. In combination with a pressing machine including a pressing bed, a clamping band
 80 disposed on one side of the bed and normally in reeled condition about a core, said clamping band having a free end, means for rotating said core to project the free end of said clamping band laterally across said bed,
 85 means normally in inoperative position for securing the free end of said clamping band on the opposite side of said bed, and means for projecting said securing means into operative position simultaneously with the projection
 90 of the free end of said clamping band laterally across said bed.

7. In combination with a pressing machine including a pressing bed, a clamping band
 95 disposed on one side of the bed and normally in reeled condition about a core, said clamping band having a free end, motor means for rotating said core to project the free end of said clamping band laterally across said bed,
 100 means normally in inoperative position for securing the free end of said clamping band on the opposite side of said bed, motor means for projecting said securing means into operative position, and means for moving said
 105 clamping band into clamping engagement with said bed when said motor means are rendered ineffective.

8. In combination with a pressing machine including a pressing bed, a clamping band
 110 disposed on one side of the bed and normally in reeled condition about a core, said clamping band having a free end, motor means for rotating said core to project the free end of said clamping band laterally across said bed,
 115 means normally in inoperative position for securing the free end of said clamping band on the opposite side of said bed, motor means for projecting said securing means into operative position, a single control means for
 120 said two motor means whereby they operate simultaneously to project the free end of said clamping band laterally across said bed and project said securing means into operative position, and means for moving said clamping
 125 band into clamping engagement with said bed when said motor means are rendered ineffective.

In testimony whereof I hereby affix my signature.

BLUFORD W. BROCKETT. 130