

June 5, 1934.

E. R. EVANS

1,962,061

ELECTRICAL SPACE DISCHARGE DEVICE

Filed March 20, 1931

Fig. 1.

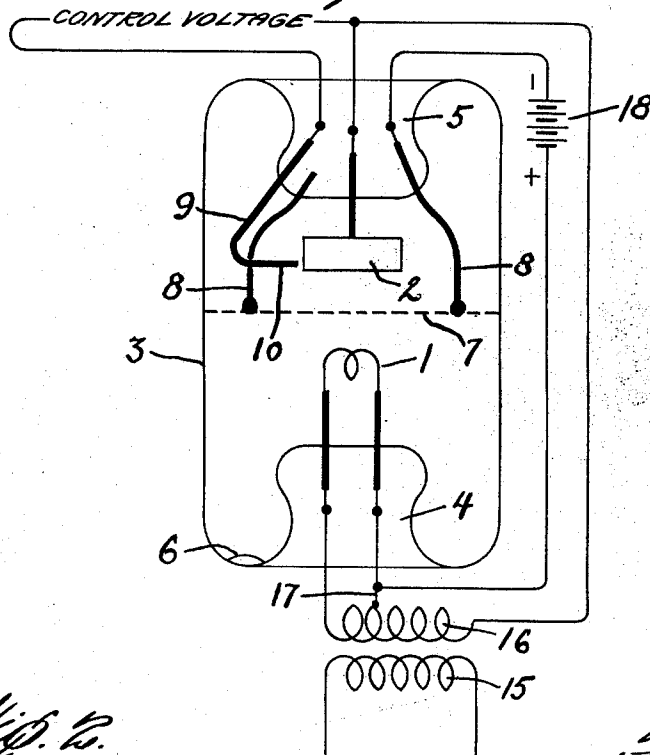

Fig. 2.

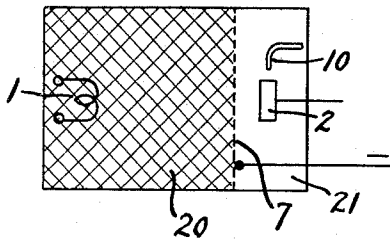

Fig. 3.

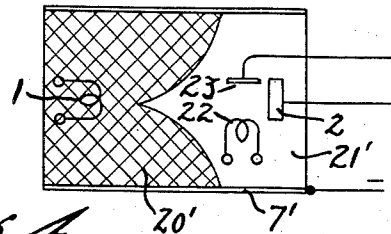
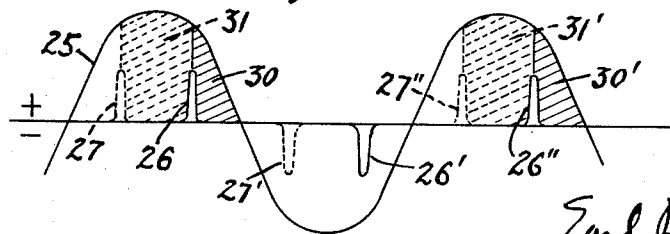

Fig. 4.



Inventor

Earl R. Evans

UNITED STATES PATENT OFFICE

1,962,061

ELECTRICAL SPACE DISCHARGE DEVICE

Earl R. Evans, Washington, D. C.

Application March 20, 1931, Serial No. 524,167

2 Claims. (Cl. 250—27)

This invention relates to space-discharge devices and more particularly to a device of this character adapted to carry large currents with a low internal voltage-drop or power loss.

5 Prior discharge devices, in spite of obvious limitations, have found wide application because of the rapidity with which the current traversing the same may be controlled or altered and because of their relay or amplifier characteristics whereby a relatively large current may be controlled by the expenditure of a small amount of energy. In vacuum tubes operating with a pure electron discharge, minute electrical variations in a control electrode or grid in the path of the discharge produce greatly amplified variations in the current traversing the tube. However such tubes are not applicable to ordinary power circuits because of the difficulty in producing enough electrons at the cathode to carry the current and further because of the excessively high voltage drop across the tube, which entails a large power loss.

If the tube contains gas or vapor, electrons may be formed by ionization in such numbers that the current-carrying capacity of the tube is increased many times and the internal voltage drop reduced to a few volts as compared with the voltage drop of hundreds or thousands of volts in an electron-discharge tube of the highly evacuated type. The control element or interposed grid is no longer operative however to control the discharge in the usual way when appreciable ionization is permitted so that the tube becomes of extremely limited utility.

35 In general terms, the object of the present invention is to provide an improved discharge device which is not limited in its current-carrying capacity to the electron-emitting capacity of a cathode and by the space-charge effect, as in pure-electron-discharge tubes, but which may be changed from the open-circuit or non-conducting condition to closed-circuit or conducting condition without appreciable time lag, or which may be used to control or regulate large currents without excessive power losses in the device. The presence of an ionizable medium in the discharge path is considered an essential feature of the invention and therefore it will be apparent that devices embodying the invention operate upon a fundamentally different principle from high vacuum electron-discharge tubes.

For a better understanding of the invention, reference may be had to the following detailed

description of the embodiment thereof shown on the accompanying drawing, wherein—

Fig. 1 is a view of a preferred construction embodying the invention;

Fig. 2 is a diagram illustrating the principle of operation of the device shown in Fig. 1;

Fig. 3 is a similar diagram of a modified construction; and

Fig. 4 is a diagram illustrating the relationship of the main and control voltages when an alternating potential is applied to the terminals of the device.

Referring more particularly to Fig. 1, a preferred form of discharge device embodying the invention comprises a cathode or source of electrons 1, such as a filament maintained at an elevated temperature, and a cooperating anode 2, of graphite or iron for example, enclosed in an envelope 3. The cathode and anode are each supported in a press 4 and 5, respectively, through which lead-in wires are sealed in the usual manner, when a glass envelope is employed.

The envelope 3 contains an ionizable medium, preferably mercury vapor at a pressure of the order of 1 to 50 microns, a drop of mercury being indicated at 6. Inert gases, such as argon or helium, at approximately the same pressure may be used instead of or in combination with mercury or other metal vapor but it is necessary to insure that the gasfilling is not destroyed or "cleaned up" by the discharge, so that the pressure falls below that necessary for proper operation. For this reason, it is preferred to use a metal vapor which is continually replenished from a drop of mercury or the like sealed within the envelope after the same has been carefully evacuated by the usual methods.

The detailed construction and arrangement of the cathode and anode may be modified in accordance with well known principles utilized in present gaseous rectifiers or discharge tubes and the diagrammatic showing in the drawing is only intended to illustrate the general arrangement thereof. For example, the source of electrons for ionizing the space between the anode and cathode may be a pool of mercury as in the mercury-arc rectifier or different types of metallic cathodes may be utilized.

A grid or screen 7, for example in the form of a perforated plate member supported by the wires 8, is arranged to extend entirely across the discharge path from cathode to anode. To secure this result, the screen 7 may obviously be

also arranged as a shell completely enclosing either the cathode or anode, and in other ways to be referred to hereinafter. Suitable arrangements of cathode, anode and grid or shield are known in the art but these prior discharge devices operate in a different manner as will be explained. In certain of these prior devices, as in the present device, the cathode produces intense ionization in the proximity thereof, which ionization may or may not extend to the region of the anode depending upon the potential of the grid or ionization shield.

The phenomena involved is understood to be substantially as follows:—The electrons formed by the cathode have sufficient velocity because of the electrical gradient resulting from the positive potential of the anode to ionize the gaseous medium by collision with the molecules thereof. Progressive ionization may occur which results in the formation of an arc extending to the anode, the current being if desired many times greater than that corresponding to the number of electrons emitted from the cathode because of the electrons formed by ionization. If the grid is at a negative potential with respect to the cathode, it will repel the negative electrons formed and attract the positive ions, and if it is sufficiently negative and does not contain too large openings, obviously it will be operative to prevent ionization of the space surrounding the anode. Under these circumstances no current passes from the cathode to the anode.

Obviously if the anode-cathode voltage is sufficiently increased or the potential of the grid is made more positive, an arc may be formed and thereafter the screen or ionization shield is inoperative to control the current being unlike the control element of a highly evacuated electron-discharge device in this respect. However if the anode-cathode voltage is periodically reduced to zero, the average current through the device depends upon the potential of the screen and, where an alternating screen potential is employed, upon the phase relation of this potential to the anode-cathode potential.

In prior discharge devices involving ionization as described above, the potential of the grid or screen electrode is varied to control the discharge current. In the present device, the screen is maintained at a substantially constant potential or at least is not utilized to control the discharge current but only as a shield to define a region which is normally de-ionized around the anode. Supported upon a wire 9 is an ionizing device 10 in the normally de-ionized region, for example, a conductor spaced from the anode 2 to provide a spark-gap.

The space-discharge device may be energized from a transformer connected to an alternating-current, 60-cycle source, the transformer comprising primary and secondary windings 15 and 16 respectively. The cathode 1 or the heating element thereof is bridged across one end of the winding 16 and a tap 17 thereon. A battery 18 or other suitable source of potential is connected to the grid or screen 7 to maintain the same sufficiently negative to prevent the formation of an arc at all times when the ionizing device 10 is inoperative.

As shown diagrammatically in Fig. 2, the screen 7 may be considered as dividing the space between the cathode 1 and the anode 2 into an ionized region 20 and a de-ionized region 21 so that normally no discharge current flows from cathode to anode. When the ionizing device 10

becomes operative, however, as by applying sufficient potential between it and the anode to form a discharge or spark therebetween, the region 21 becomes ionized and an arc forms between the cathode and anode. The potential drop in the arc is small, being of the order of 15 volts ordinarily, so that only a small power loss is encountered.

As shown in Fig. 3, the shielding electrode 7' may be formed as an imperforate cylindrical member surrounding the discharge space which is divided into the ionized region 20' and the de-ionized region 21'. The ionizing device located in the normally de-ionized region may take various forms as understood by those skilled in the art. For example, a heated cathode 22 and a cooperating anode 23 may be provided to produce a space discharge to ionize the region 21' and thereby establish a space-discharge current between the cathode 1 and anode 2. The negative screen-element 7' may form a portion of the envelope of the discharge device, if desired.

The device described finds numerous applications in electrical systems, for example, as a relay or for closing an electrical circuit including an electrical translating device. If an alternating potential is applied to the anode and cathode of the device, the frequency or timing of the operation of the ionizing device controls the average current between anode and cathode and the device may be employed for regulating purposes and the like. Thus, as shown in Fig. 4, if an alternating potential 25 is applied to anode and cathode, an ionizing impulse or discharge represented at 26 in its relation to the anode-cathode potential causes current to flow through the device for the duration of the half-cycle as indicated by the shaded area 30. The impulse 26', occurring when the anode 2 is negative with respect to the cathode 1, does not cause the discharge current to flow. The next impulse 26'' is again operative to cause a discharge current as represented by the shaded area 30. If the timing of the ionizing impulses is varied, as indicated at 27, 27', 27'', the average discharge current is changed as indicated by the shaded areas 31, 31'. In certain cases, ionizing impulses which do not occur during each cycle or each half-cycle of the anode-cathode potential may be employed. The average current in such cases will correspond roughly to the frequency of such impulses.

Various modifications in the construction of the discharge device, some of which are suggested above, will occur to those skilled in the art and are intended to come within the scope of the invention as defined in the appended claims.

I claim:

1. In combination, a gaseous or vapor conduction valve provided with an anode, a cathode, a shielding electrode of substantially constant potential with reference to said cathode for shielding the discharge path between said anode and said cathode and a fourth electrode adjacent the discharge path, an alternating-current circuit connected to the anode and cathode of said valve, an alternating-current source in said anode-cathode circuit, and means including said fourth electrode and a source of periodic current impulses of predetermined phase relation to said alternating-current source connected thereto for determining the average current traversing said valve by rendering said valve conductive at predetermined points in the cycles

of alternating potential applied to the anode-cathode circuit.

2. In combination, a gaseous or vapor conduction valve provided with an anode, a continuously operative cathode adapted to emit electrons to ionize the gas filling, a shielding electrode of substantially constant potential with reference to said cathode and arranged to shield the space adjacent said anode from the ionization produced by said cathode and a fourth electrode adjacent said shielded space, an alternating-current circuit connected to the anode

and cathode of said valve, an alternating current source in said anode-cathode circuit, and means including said fourth electrode and a source of periodic current impulses of predetermined phase relation to said alternating-current source connected thereto for determining the average current traversing said valve by rendering said valve conductive at predetermined points in the cycles of alternating potential applied to the anode-cathode circuit.

EARL R. EVANS.

15	90
20	95
25	100
30	105
35	110
40	115
45	120
50	125
55	130
60	135
65	140
70	145
75	150