

W. RANDALL.
Injectors for Steam-Boilers.

No. 157,105.

Patented Nov. 24, 1874.

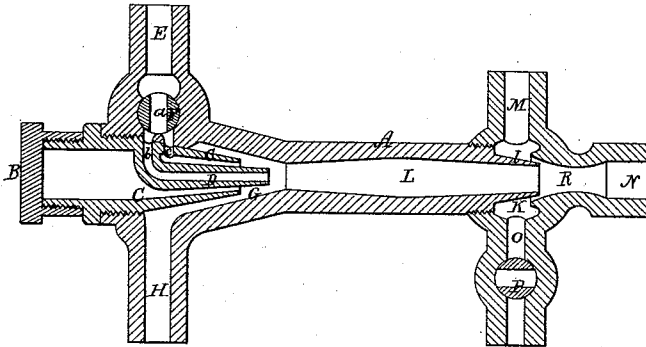

Witnesses:

S. W. Peper
S. N. Spotted

William Randall.

by his attorney.

R. H. Eddy

UNITED STATES PATENT OFFICE

WILLIAM RANDALL, OF SALEM, MASSACHUSETTS.

IMPROVEMENT IN INJECTORS FOR STEAM-BOILERS.

Specification forming part of Letters Patent No. **157,105**, dated November 24, 1874; application filed October 14, 1874.

To all whom it may concern:

Be it known that I, WILLIAM RANDALL, of Salem, of the county of Essex and State of Massachusetts, have invented certain new and useful Improvements in Injectors for Boilers; and do hereby declare the same to be fully described in the following specification and represented in the accompanying drawing, which denotes a longitudinal section of an injector with my invention.

In my present injector the two rear nozzles are provided with separate passages of communication with the steam-induct, and the latter has in it a stop-cock having a steam way or passage, by which steam may be let into either or both the nozzles. The said injector not only has such appliances, but has the larger nozzle open at its rear end, and there provided with a closing-cap, and it also has a water-induct opening into the chamber about the nozzles. Furthermore, it has, between its foremost and rearmost nozzles, an antifrictional enlargement or chamber. It also has the foremost nozzle arranged to project entirely across its surrounding chamber, and into the educt thereof.

In the drawings, A denotes the body of the injector, it being open at its rear to receive the nozzle C, which screws into the body, is also open at its rear end, and there is provided with a cap or cover, B, to screw upon it. Within the body are two nozzles, C D, one being arranged within and fixed to the other, in manner as shown. Within the induct E, which is for the introduction of steam into the injector, is a stop-cock, F, provided with a steam way or passage, a. Furthermore, the nozzle D opens into the induct E by a passage, b, near to, and separate from, another passage, c, leading from the induct E into the nozzle C. The passage a is wider than the space between the passages b c, the whole being so that the passage a, by turning the cock, may be brought into communication with either or both of the nozzles C D, whereby steam may be caused to flow into one or the other, or both, of said nozzles, as occasion may require, they being surrounded by a conical chamber, G, provided with a water-induct, H. This chamber G is separate from the nozzle C, which serves to close said chamber at its rear.

By removing the cap B from the nozzle C access may be had to the interior of the said

nozzle C, in order to clear it of obstructions, whenever such may be necessary. So, by unscrewing the nozzle from the chamber G, access may be had thereto for cleansing it.

In advance of the two nozzles D C is a third nozzle, I, surrounded by a chamber, K. Between this latter nozzle I and the others is what I term the anti-friction chamber L or passage, larger at its middle than at either terminus, and tapering from such middle to each terminus, as shown; the object of the enlargement of the conduit leading from the rear nozzles to the foremost one being to diminish the friction of the column of fluid in passing from the chamber G into the nozzle I relatively to what would result were the passage of equal diameter throughout.

The chamber K has one induct, M, and two educts, N O, arranged as shown, the educt O being provided with a stop-cock, P. The induct M is for admission of heated water, the educt O being for the overflow, as usual; while the educt N leads to the boiler when the apparatus is in use. The nozzle I extends across the chamber K, and a short distance into the tapering mouth R of the educt N, all being as represented. This prevents the water flowing into and out of the chamber K from crossing the outer end of the nozzle I, so as to obstruct the direct flow of fluid therefrom, as it would were the nozzle arranged wholly in the chamber K, and not within the mouth of the educt.

In the above-described injector, I claim as my invention as follows, viz:

1. The internal and external nozzles C D, provided with the passages b c, for connection with the steam-induct E, in combination with the cock F, arranged in the induct, and provided with the passage a, to engage with either or both the said passages b c, all as set forth.

2. The larger nozzle C, open at its rear, and provided with the cap or cover B, in combination with the body A, provided with the chamber G, the steam-induct E, and the water-induct H, all as set forth.

3. The front nozzle I, arranged to extend across its chamber K, and within the mouth R of the educt N, all as shown and described.

WILLIAM RANDALL.

Witnesses:

R. H. EDDY,
J. R. SNOW.