



(12) **EUROPEAN PATENT APPLICATION**

(43) Date of publication:
01.03.2006 Bulletin 2006/09

(51) Int Cl.:
E04F 11/18^(2006.01)

(21) Application number: **05076946.2**

(22) Date of filing: **24.08.2005**

(84) Designated Contracting States:
**AT BE BG CH CY CZ DE DK EE ES FI FR GB GR
HU IE IS IT LI LT LU LV MC NL PL PT RO SE SI
SK TR**
Designated Extension States:
AL BA HR MK YU

(72) Inventor: **Jones, Kevin
Norfolk (GB)**

(74) Representative: **Sanderson, James L.C. et al
Sanderson & Co.,
34, East Stockwell Street
Colchester,
Essex CO1 1ST (GB)**

(30) Priority: **24.08.2004 GB 0418862**

(71) Applicant: **Trident Industrial Limited
East Harling
Norfolk
NR16 2QN (GB)**

(54) **Modular handrail systems**

(57) The present invention comprises a kit for construction of a handrail assembly and a modular handrail system. The kit and system include at least one cross connector (30,31) having four male projections (18) in opposed pairs; and at least one T-shaped connector (25,26) having three male projections. The kit includes a plurality of elongate tubular sections (40) that connect between two male projections of different connectors to

form an assembly of intersecting legs and rails. At least one base member (35) adapted to connect to the end of a tubular section and to an external structure (61) is also provided to mount the handrail assembly. Each male projection has an annular rib (19) that engages in a groove (42) formed in the inner surface of each tubular section. Further connector types including curved connectors (15,22), straight connectors, and variable angle connectors (60) may also be included.

Figure 10

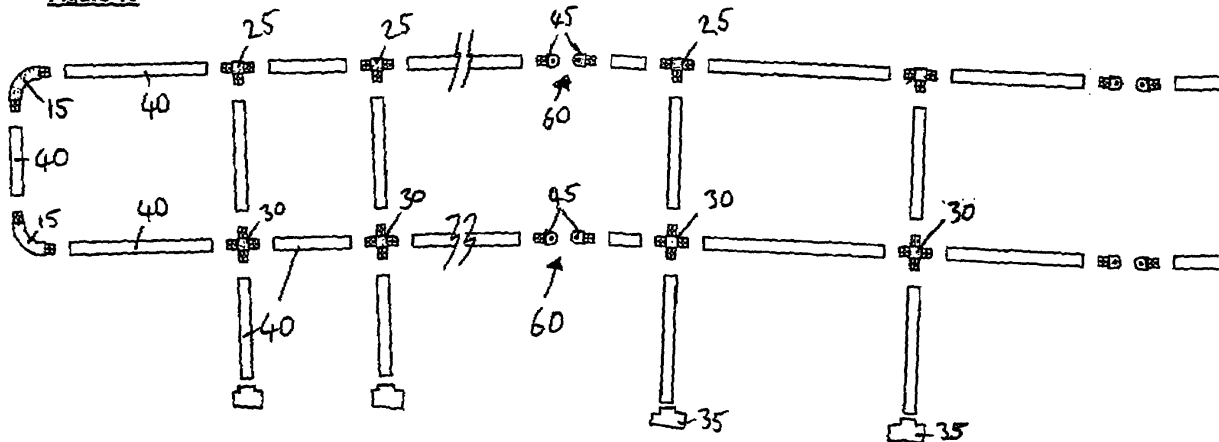

Description

[0001] The present invention relates to modular handrail systems and in particular to a kit of parts for assembly into such handrails, as well as a modular handrail system constructed therefrom.

[0002] For safety and other reasons handrails must be provided in a variety of temporary and permanent locations. One example is when providing ramps or steps for gaining access into buildings or otherwise. Such ramps and steps must now be provided with some form of handrail system to aid people using the ramps or steps and to improve their safety. Whilst handrails have previously been provided, the present invention aims to improve upon these and to provide a modular handrail system that may be easily constructed into a variety of different configurations to suit the particular circumstances of its use. It is a further aim to provide a handrail system that is light and strong as well as being resistant to atmospheric degradation and cost efficient to produce. It is a further aim to provide a handrail that may be easily and swiftly assembled and disassembled in situations where only a temporary construction is required.

[0003] As used herein the terms "handrail", "railings" or "handrail system" are used to describe a fence-like or barrier-like structure, usually but not exclusively vertically arranged, and having one or more leg and one or more rail running approximately perpendicular to the legs - and usually parallel to the surface. The purpose of such items is to provide a means of support to those holding it and to prevent accidental falls or improper passage of persons.

[0004] Therefore, according to the present invention there is provided a kit of parts for construction of a handrail assembly, said kit including at least one cross connector having male projections in an opposed pair; at least one T-shaped connector having at least one male projection; a plurality of elongate tubular sections each adapted to connect to the male projections of different connectors thereby to form an assembly of intersecting legs and rails; and at least one base member that is adapted to connect to the end of a tubular section and to an external structure to mount the handrail assembly thereon, each male projection having an annular rib that engages in a groove formed in the inner surface of each tubular section.

[0005] In addition to the connectors described above it is preferred that the kit is also provided with one or more curved connector having two male projections formed at an angle, less than 180° , relative to each other. Such a curved projector will often have the male projections formed at substantially 90° relative to each other such that the connector may connect a horizontal and a vertical tubular section to form a smooth corner. The diameter of that curve may vary dependent upon the particular application. For example a large diameter curve may be appropriate when terminating a rail at a free end by joining it to a rail below, but a small diameter curve is usually

better when turning a horizontal corner on a rail.

[0006] There may further be provided within the kit a variable angle connector having two parts each provided with a male projection and each being moveable relative to the other. Such a variable connector would preferably comprise two parts pivotally connected to each other such that a desired relative angle of the male projections and hence any tubular sections to which they are connected can be achieved, by pivoting about a common axis of rotation.

[0007] The cross-connector and the T-shape connectors may comprise two opposed pairs of male projections and these may be generally regular in orientation with the connectors at right angles to each other such that the tubular sections connected thereto are also substantially at right angles. This is particularly appropriate where a railing is to extend along a flat surface and each rail is to run essentially parallel to that surface and perpendicular to each leg. However, in some circumstances such as when ascending stairs or a relatively steep incline it is appropriate to have the legs remain essentially vertical (rather than perpendicular to the general incline of the surface) but the rails should remain essentially parallel to that surface incline. To achieve this it is preferable that with respect to the cross-connector one opposed pair of male projections is at an acute angle to the other pair of opposed male projections, the male projections being all in the same plane. With respect to the T-shaped connector, this may comprise three male projections, and tubular sections may attach to each of these projections. The T-shaped connector often forms the upper end of a leg and connects to an uppermost rail. It may provide suitable angles and it is preferred that there is a pair of diametrically opposed male projections that connect to the tubular sections forming an upper rail and that the other male projection is formed at an acute angle relative to one of those male projections. Again all male projections are in substantially the same plane. A kit may include both angles and regular T-connectors and cross connectors.

[0008] The kit of parts may include one or more half connector that defines a single male projection and is connectable to a middle portion of a tubular section. Such a half connector can be used in addition to the cross connectors and T-shaped connectors, but can also be used to form such connectors. For example, the cross connector may comprises two half connectors that each define a male projection, the two half connectors being attachable to opposite sides of a tubular section. Also a T-shaped connector may comprise a single half connector attached to the middle of one tubular section and the end of another.

[0009] Each half connector may preferably have a channel shaped base portion that locates around the external surface of the tubular section, and a male projection extending in the opposite direction therefrom. The channel shaped base portion will have a profile that matches the shape of the tubular section, and the male projection may be formed at a range of angles to the axis

of the tubular section to which the half connector is attached.

[0010] It is possible that the constituent parts of the present invention can be constructed from a variety of different materials, including metal. However, it is particularly preferred that each component is constructed wholly or predominantly from a plastics material, due in part to their high strength to weight ratios. The plastics material may also include reinforcing filler materials such as fibres. Preferably the connectors are formed by moulding and the tubular sections, which are usually elongate and rectilinear, are formed by extrusion.

[0011] Preferably the tubular sections are generally circular in cross-section and define a generally circular hollow interior. It is preferred that the male projections are also generally circular in cross-section and are adapted to be a tight fit within the hollow interior of the tubular section.

[0012] The hollow interior of the tubular section has at least one groove formed therein to receive the rib on each male projection, which serves not only to ensure correct angular orientation but also prevents any rotation of the tubular section relative to the male projection. There may be more than one groove, which can be adapted to accommodate more than one rib on the male projections or may allow the tubular section to adopt a number of acceptable angular positions relative to the male projection.

[0013] It is preferred that each connector, with the possible exception of the variable angle connector and half connector, has a main body and male projections extending therefrom. It is preferred that the main body is approximately equivalent in dimensions and profile to the tubular sections. This helps to ensure that there is a regular, smooth and continuous external profile regardless of whether it is a tubular section or a part of a connector. The male projections extend from the main body of each connector and are slightly smaller in diameter such that they are a snug fit within the hollow tubular sections.

[0014] The tubular sections are usually intended to be gripped by the hand and consequently they may be provided with grip enhancing features such as ridges. Preferably the connectors are distinguishable by touch from the tubular sections so that someone of impaired sight can distinguish by touch alone when their hand passes over a connector, thus giving a guide to the distance travelled.

[0015] According to the present invention there is further provided a handrail when constructed from a kit of parts as previously defined.

[0016] According to a third aspect of the invention there is yet further provided a modular handrail system having a plurality of legs and at least one rail, the system comprising T-connectors having at least one male projection and located at the upper end of each leg, a plurality of cross connectors having at least two male projections in an opposed pair, elongate tubular sections, the open ends of which connect around the male projections of

the T-connectors and cross connectors to interconnect them to form the legs and at least one rail, and a base member adapted to connect to a free end of a tubular section either of a leg or a rail and to an external structure to connect the leg or rail thereto, each male projection having an annular rib that engages in a groove formed in the inner surface of each tubular section.

[0017] The modular handrail system as described above is subject where possible to the same preferred features as described with reference to the kit of parts of the first aspect of the invention.

[0018] In order that the present invention be better understood, but by way of example only, an embodiment of the invention will now be described in more detail with reference to the accompanying drawings in which:

Figure 1 is a perspective view of a 90° curved connector;

Figure 2 is a perspective view of an alternative smaller diameter 90° curved connector;

Figure 3 is perspective view of a 90° T-connector;

Figure 4 is a perspective view of an angled T-connector;

Figure 5 is a perspective view of a 90° cross-connector;

Figure 6 is a perspective view of an angled cross-connector;

Figure 7 is a perspective view of a base member in the form of a connector plate;

Figure 8 is cross section through a tubular section;

Figure 9 is a perspective view of one half of a variable angle connector.

Figure 10 is an exploded view of one possible assembly of components to form a handrail;

Figure 11 is a similar view to that of Figure 10 but showing the handrail fully assembled, with the components interconnected.

Figure 12 is a side view of a half connector;

Figure 13 is a plan view of the half connector of Figure 12; and

Figure 14 is an exploded view of leg of a handrail assembly utilising the half connector of Figures 12 and 13.

[0019] Figure 1 shows a large diameter 90° curved connector generally indicated 15. This curved connector 15 will usually be used as an end bend and is of a relatively large diameter of curvature. The curved connector 15 comprises a main body 16 which is generally curved and circular in cross-section, with a diameter equivalent to the tubular section described below. A series of depressions 17 are formed in the main body 16 and male projections 18 extend from the two ends, The male projections 18 are generally circular in profile and each has a radially extending rib 19 provided thereon that runs parallel to the axis of the projection. One or more recess 20 is provided on each male projection 18 to receive a fixing screw (not shown). The male projections 18 are

inserted into the hollow interior of the tubular sections and the fixing screws if needed pass through the wall of the tubular section to engage in the recess 20. The recesses may be provided with a thread or may be adapted to receive a self-tapping screw.

[0020] The smaller diameter curved connector shown in Figure 2 is generally indicated 22 and, apart from the length of the main body 16 and the radius or curvature, is essentially identical to that described in Figure 1 and like parts have been given like reference numerals.

[0021] Figure 3 shows a 90° T-connector generally indicated 25 and Figure 4 shows an alternatively angled T-connector generally indicated 26. These T-connectors are usually intended to form the upper end of a leg (which itself comprises one or more tubular section and other connectors). Each T-connector 25, 26 has three male projections 18, two of which are formed at 180° to each other in an opposed pair, which pair connects to tubular sections to form the upper rail of a handrail assembly. The third or middle connector, labelled 18A for convenience, is intended to connect to the upper end of an upper tubular section of a leg of the rail assembly. In the regular 90° embodiment labelled 25 the middle male projection 18A is formed at 90° to the other male projections. However, in the angled embodiment shown in Figure 4 the middle male projection 18A is formed at an acute angle with respect to one of the others and an obtuse angle to the other. Each connector still comprises a main body which is essentially similar to that of the curved connectors but is herein labelled 27 and 28 due to their alternative configurations. Although not all visible in this view, each male projection 18 and 18A have a rib 19 formed thereon as well as screw recesses 20. T-connectors could also be used to terminate a rail section in a leg, such that the opposed pair connect to tubular sections forming part of the leg and the middle male projection 18A connects to a tubular section forming part of the rail.

[0022] Figures 5 and 6 show regular and angled embodiments of cross-connectors. In the regular embodiment of Figure 5, which is generally indicated 30, each male projection 18 is formed at substantially right angles to each other in opposed pairs, all male projections being in the same plane. This cross connector 30 would be used to connect four tubular sections together and generally one opposed pair would connect together tubular sections forming part of a leg and the other opposed pair would connect tubular sections forming part of an intermediate (i.e. not upper) rail. Again, each male projection would be provided with the rib 19 and the screw recesses 20, even though not all parts are visible in Figures 5 and 6.

[0023] The embodiment of Figure 6 is essentially equivalent to that shown in Figure 5, but this angled cross-connector generally indicated 31 has one pair of opposed male projections 18 formed at an acute angle to the other pair. This arrangement allows a leg and a rail of the assembly to be formed at an angle relative to each other, other than 90°, such that a leg may remain essentially vertical whilst the rail that it supports may run

parallel to the surface adjacent which the railing assembly is constructed.

[0024] Figure 7 shows a base member in the form of a connector plate generally indicated 35. This connector plate 35 is adapted to receive the end of a tubular section within an aperture 36 formed by an upstanding sleeve 38 and the connector plate 35 may then be connected by screws or other suitable fixings passing through apertures 37 to an external structure such a floor. Such a connector plate 35 can be used to connect the lower end of a leg to a floor or ramp, but also can be used to connect the end of a rail to a vertical surface such as a wall. It is also possible for the connector plate 35 to be provided with a male projection equivalent to those described above such that the joined tubular section connects around the male projection rather than locating into the recess 36.

[0025] A cross-section through a tubular section 40 generally indicated is shown in Figure 8. In this particular embodiment of tubular section 40, the external surface is provided with raised and lowered regions in order to improve the grip. The tubular section 40 has an equivalent cross-section along its entire length, and formed by extrusion of like technique. It can be formed in long sections that may be cut to an appropriate length to suit particular requirements. The tubular section 40 is generally circular and has a hollow interior 41. Channels 42 are formed on the inner surface 43 of the tube and the ribs 19 provided on the male projections 18 are adapted to locate within one of these channels 42 to prevent rotation of the tubular section 40 about the male projection 18.

[0026] Figure 9 shows one half of a variable angled connector. The half, which is generally indicated 45, has a male projection 18 and associated components such as the rib 19 and is adapted to connect at a variety of pivotal angles to a second like half (not shown). The main body of the half 45 has a flat plate 46 and a pivot bore 47. The equivalent parts of a second half are aligned such that the pivot bores 47 coincide and the two halves can be connected together by a pivot pin (not shown), or by a male part on one half locating into the pivot bore of the other. This provides a connector that can be used to alter the angle at which a rail or leg extends.

[0027] Figures 10 and 11 show respectively an exploded and a constructed view of part of a rail assembly constructed from some of the components previously discussed. As can be seen, a series of intersecting legs and rails are constructed. Each leg is formed from a T-connector 25, a cross-connector 30, a connector plate 35 and two tubular sections 40. Generally horizontal rails are then formed by inter-connecting the laterally extending male projections 18 on the T-connectors 25 and the cross-connectors 30 with further tubular sections 40.

[0028] A curved free end of the rail assembly is formed using two curved connectors 15 and a shortened tubular section 40 in a U-shaped configuration to connect the ends of the substantially parallel rails. A variable angle connector generally indicated 60, formed from two con-

stituent halves 45 and is used to alter the angle of the rails.

[0029] The lower ends of the lowermost tubular sections 40 are located into the aperture 36 of the connector plates 35 which, as best shown in Figure 11, are connected to a surface 61 upon which the rail assembly overall is mounted.

[0030] Although not shown, the angled T-connectors 26, angled cross-connectors 27 and the smaller diameter curved connectors 22 could all be used to make different or more complicated handrail assemblies dependent upon the requirement. Similarly, the connector plates 35 can be attached to a wall at a termination of a generally horizontal rail as well as supporting the lower end of a leg section 50.

[0031] Figures 12 and 13 show a half connector generally indicated 70. This half connector comprises a curved base region 71 and a male projection 18 extending therefrom for connection to a tubular section as described above. The curved base region locates around the curved surface of a tubular section and is connected thereto using suitable means such as bolts, screws or adhesive.

[0032] Figure 14 shows a leg of a possible assembly using two half connectors 70 to form a cross connector. A length 73 of tubular section connects to the male projection 74 of a base member 75 to fix the leg down to an external structure. A T-connector 25 connects to the upper end of the length 73 for forming a top rail. Approximately half way up the length 73 two half connectors 70 are connected to opposed sides thereof. A bolt 76 passes through each half connector and a transverse hole in the length 73, and a nut 77 is threaded thereon. Tubular sections may be attached to the male projections 18 of the half connectors 70 to form a lower rail (not shown).

Claims

1. A kit for construction of a handrail assembly, said kit including at least one cross connector having male projections in an opposed pair; at least one T-shaped connector having at least one male projection; a plurality of elongate tubular sections each adapted to connect to the male projections of different connectors thereby to form an assembly of intersecting legs and rails; and at least one base member that is adapted to connect to the end of a tubular section and to an external structure to mount the handrail assembly thereon, each male projection having an annular rib that engages in a groove formed in the inner surface of each tubular section.
2. A kit of parts as claimed in claim 1, which further comprises one or more curved connector with two male projections at an angle of less than 180° with respect to each other.
3. A kit of parts as claimed in claim 1 or claim 2, which further comprises a variable angle connector having two movable parts each provided with a male projection, and each being moveable relative to the other to change the relative angle of each male projection.
4. A kit of parts as claimed in any if the preceding claims wherein the connectors, tubular sections and base member are formed from plastics material.
5. A kit of parts as claimed in claim 4 wherein the connectors and base member are formed by moulding and the tubular sections are formed by extrusion.
6. A kit of parts as claimed in any if the preceding claims, wherein the tubular sections are generally circular in cross section, and have more than one groove to receive the rib on the male projection.
7. A kit of parts as claimed In any If the preceding claims wherein the cross connector comprises two pairs of opposed male projections, and tubular sections attach to each of these.
8. A kit of parts as claimed in any if the preceding claims wherein the T-connector comprises defines three male projections, and tubular sections attach to each of these
9. A kit of parts as daimed in any if the preceding claims wherein there is included a half connector that defines a single male projection and is connectable to a middle portion of tubular section.
10. A kit of parts as claimed in any of claims 1 to 6, wherein the cross connector comprises two half connectors that each define a male projection, the two half connectors being attachable to opposite sides of a tubular section.
11. A kit of parts as claimed in claim 9 or claim 10 wherein the or each half connector has a channel shaped base portion that locates around the external surface of the tubular section, and a male projection extending therefrom.
12. A kit of parts as claimed in any if the preceding claims wherein at least some of the connectors has a main body, that is approximately equivalent in dimensions to the outer dimensions of the tubular sections, and the male projections are slightly smaller and are a snug fit within the open end of a tubular sections.
13. A kit of parts as claimed in any if the preceding claims, in which the tubular sections are tactilely distinguishable from the main bodies of the connectors.

14. A handrail constructed from a kit of parts as claimed in any of the preceding claims.
15. A modular handrail system having a plurality of legs and at least one rail, the system comprising T-connectors having at least one male projection and located at the upper end of each leg, a plurality of cross connectors having two projections in an opposed pair; elongate tubular sections, the open ends of which connect around the male projections of the t-connectors and cross connectors to interconnect them to form the legs and at least one rail, and a base member adapted to connect to a free end of a tubular section either of a leg or a rail and to an external structure to connect the leg or rail thereto, each male projection having an annular rib that engages in a groove formed in the inner surface of each tubular section.
16. A modular handrail system as claimed in claim 15, wherein tubular sections are also connected to each other using variable angle connectors having two movable parts each provided with a male projection, and each being moveable relative to the other to change the relative angle of each male projection, and or curved connectors with two male projections at an angle of less than 180° with respect to each other.
17. A modular handrail system as claimed in claim 15 or claim 16 wherein the connectors, tubular sections and base member are formed from plastics material.

5

10

15

20

25

30

35

40

45

50

55

Figure 1

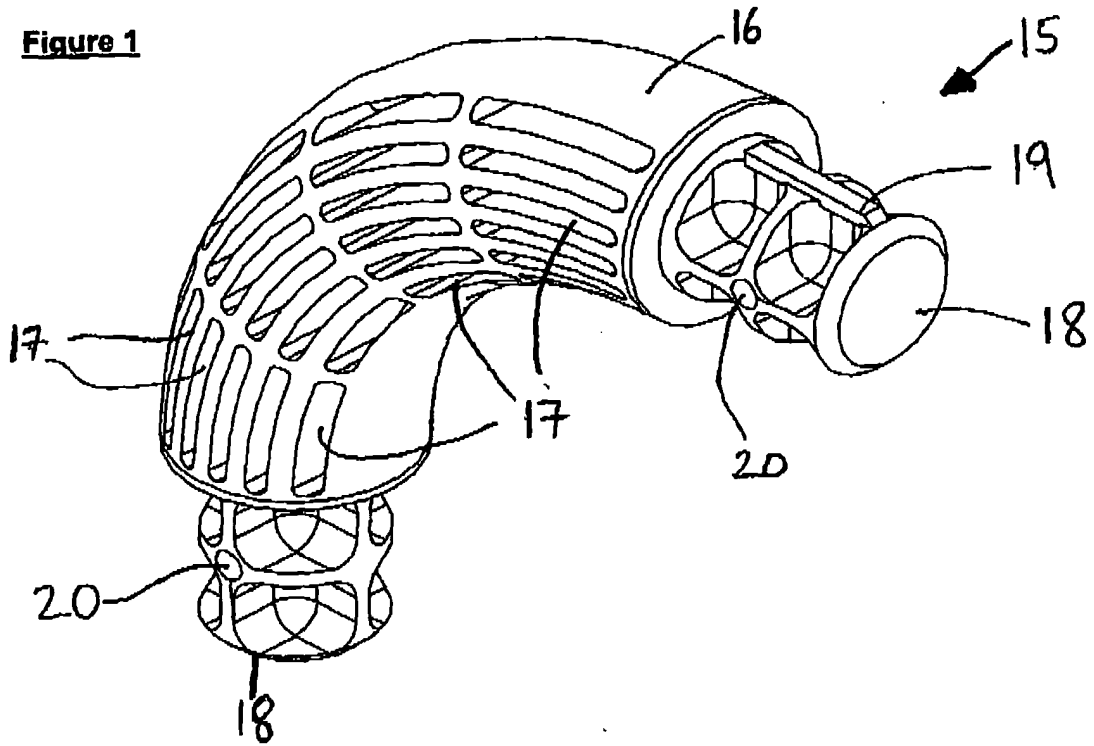
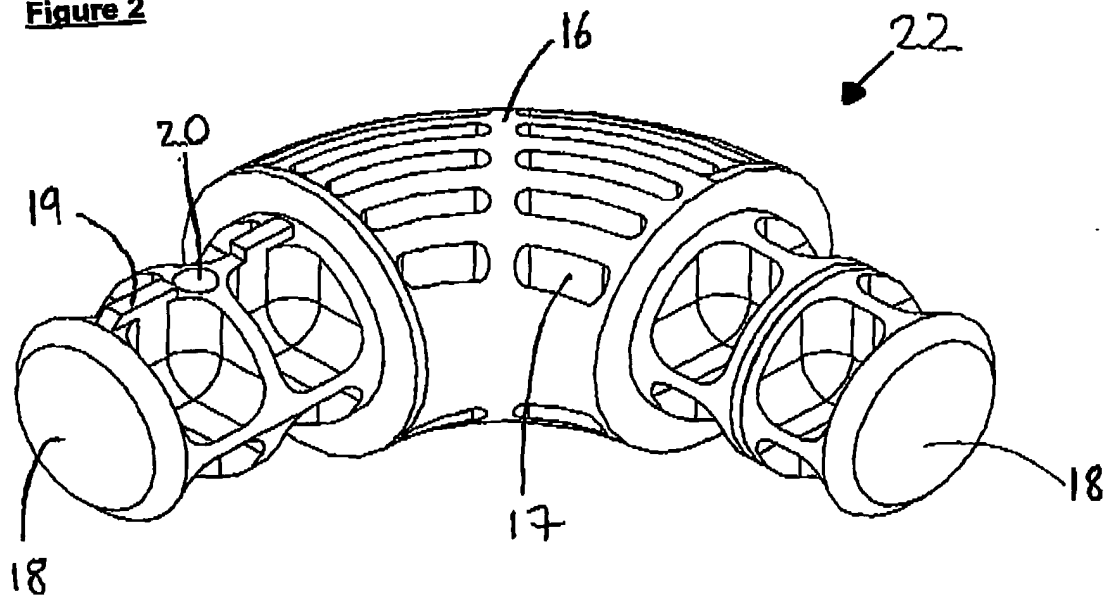

Figure 2



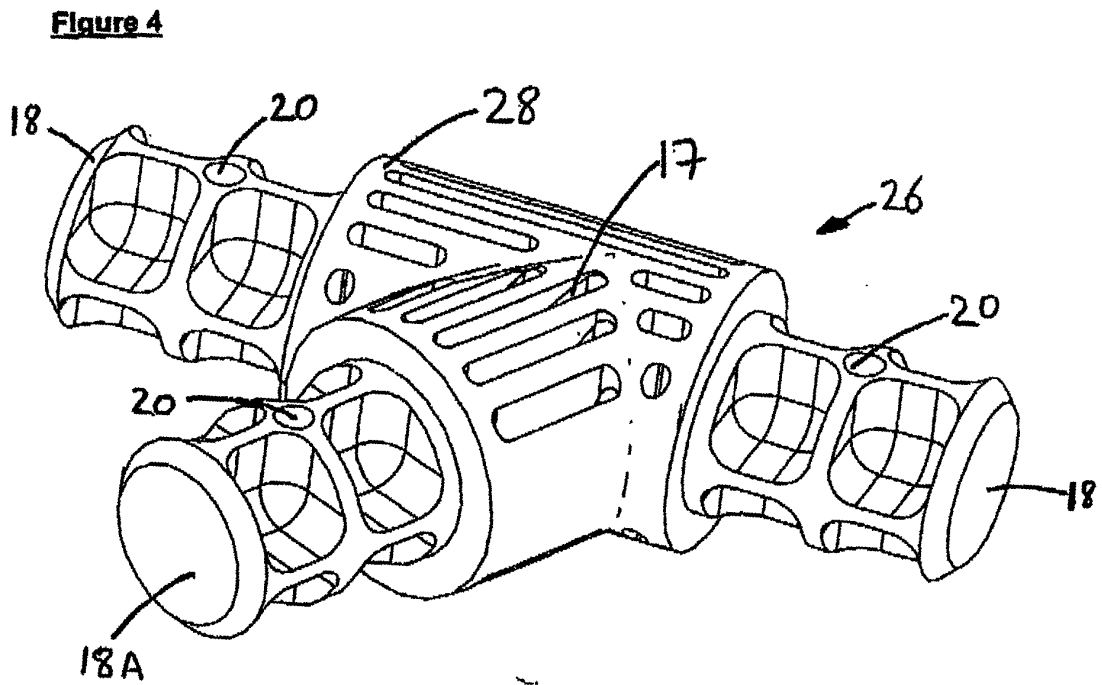
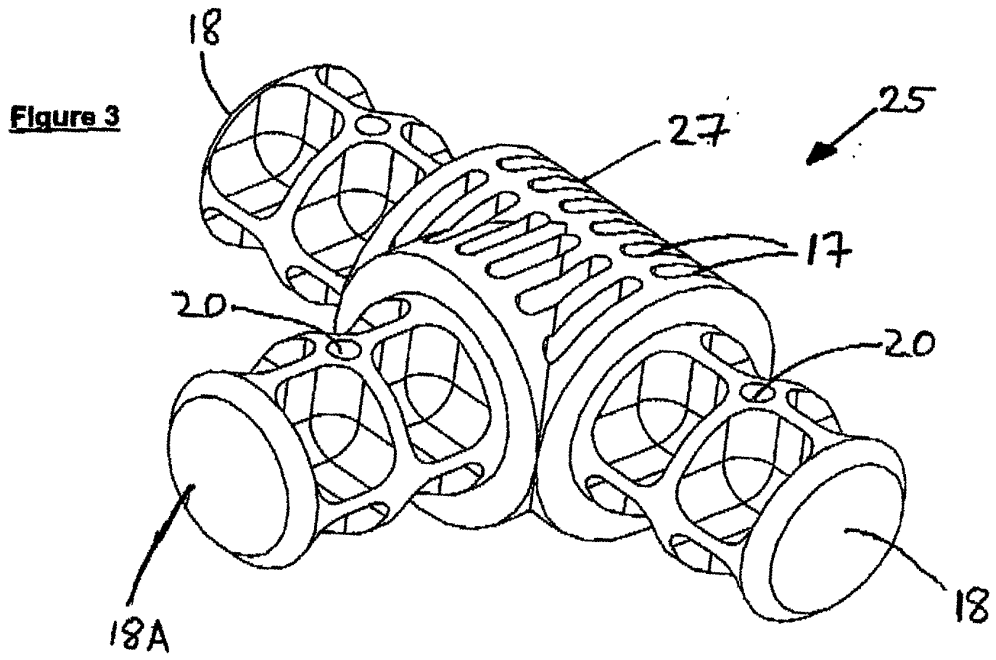

Figure 5

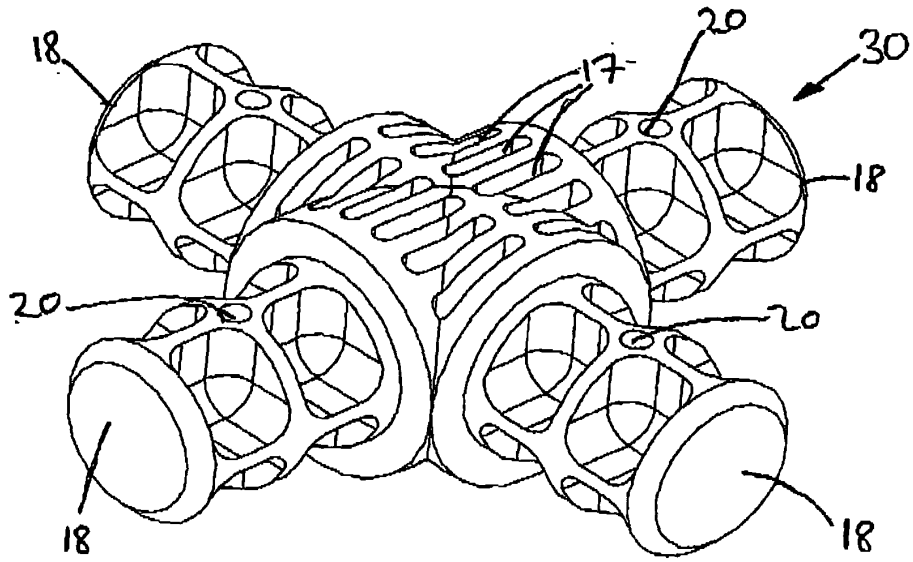

Figure 6

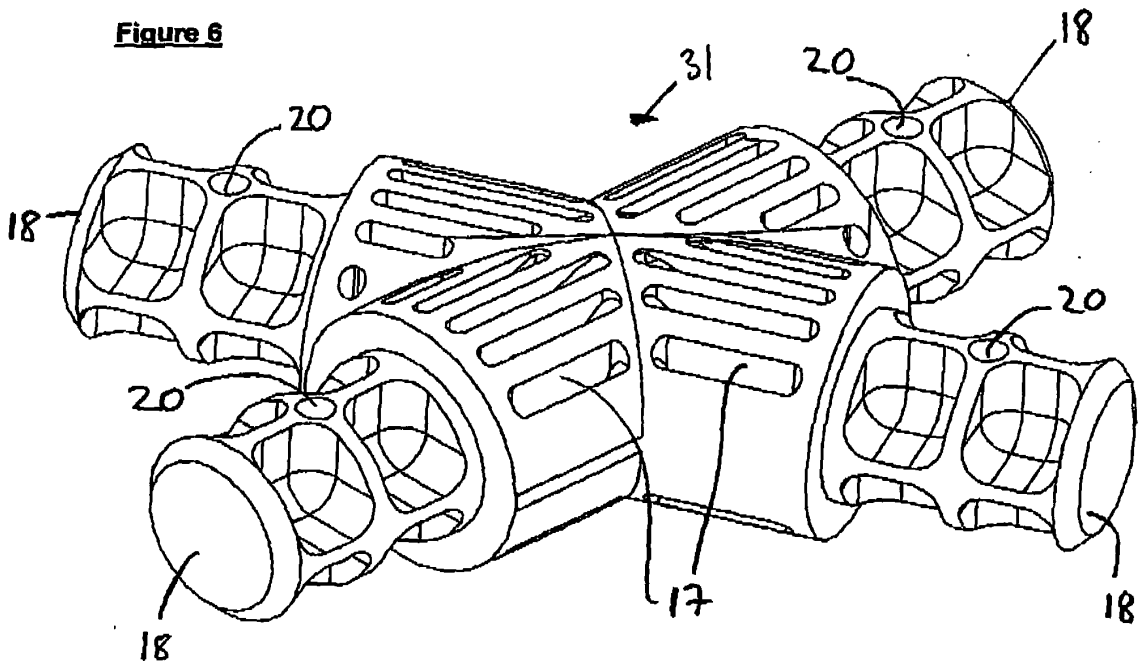

Figure 7

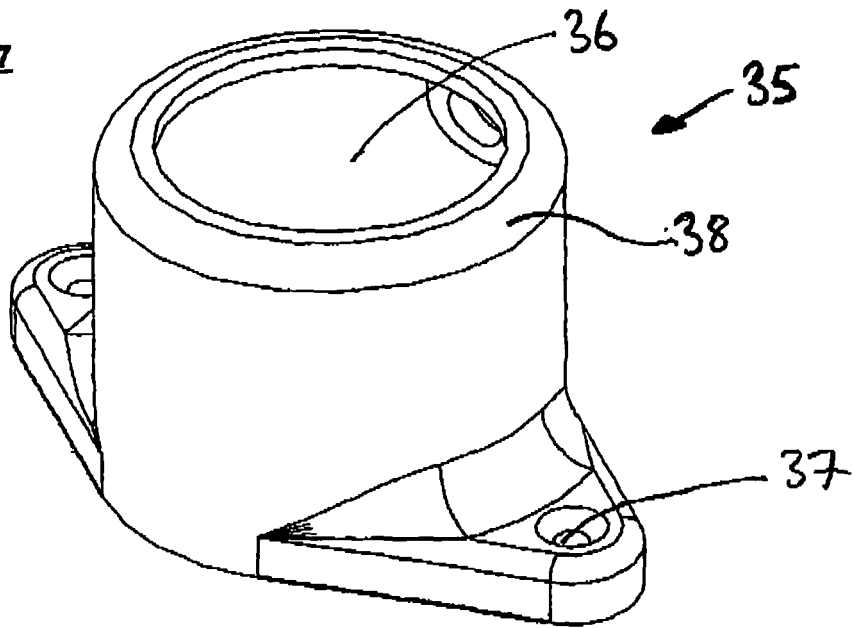

Figure 8

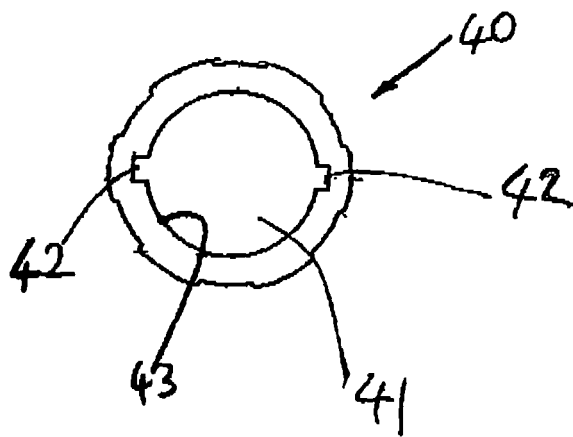

Figure 9

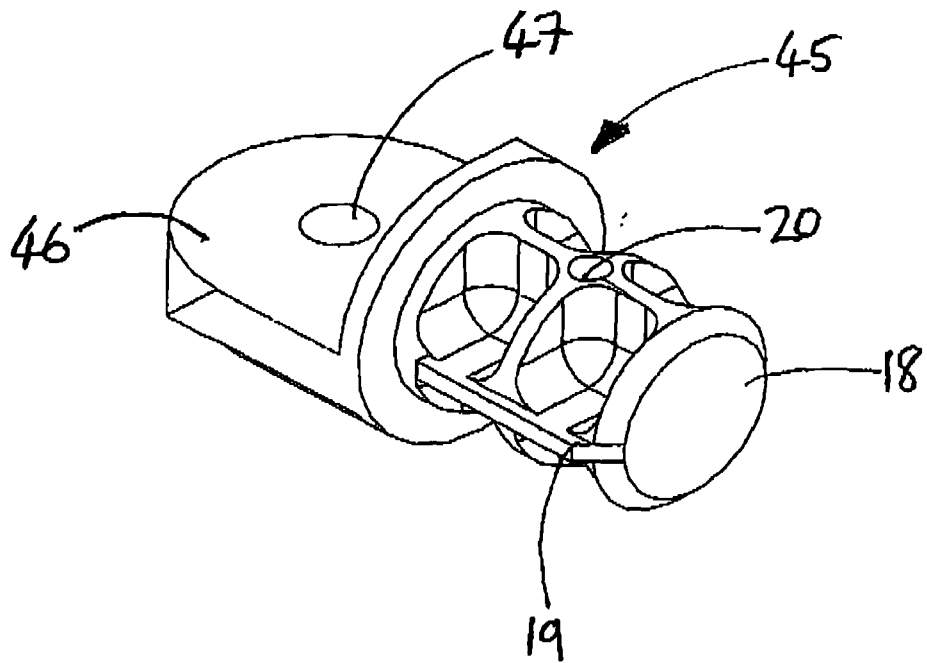

Figure 10

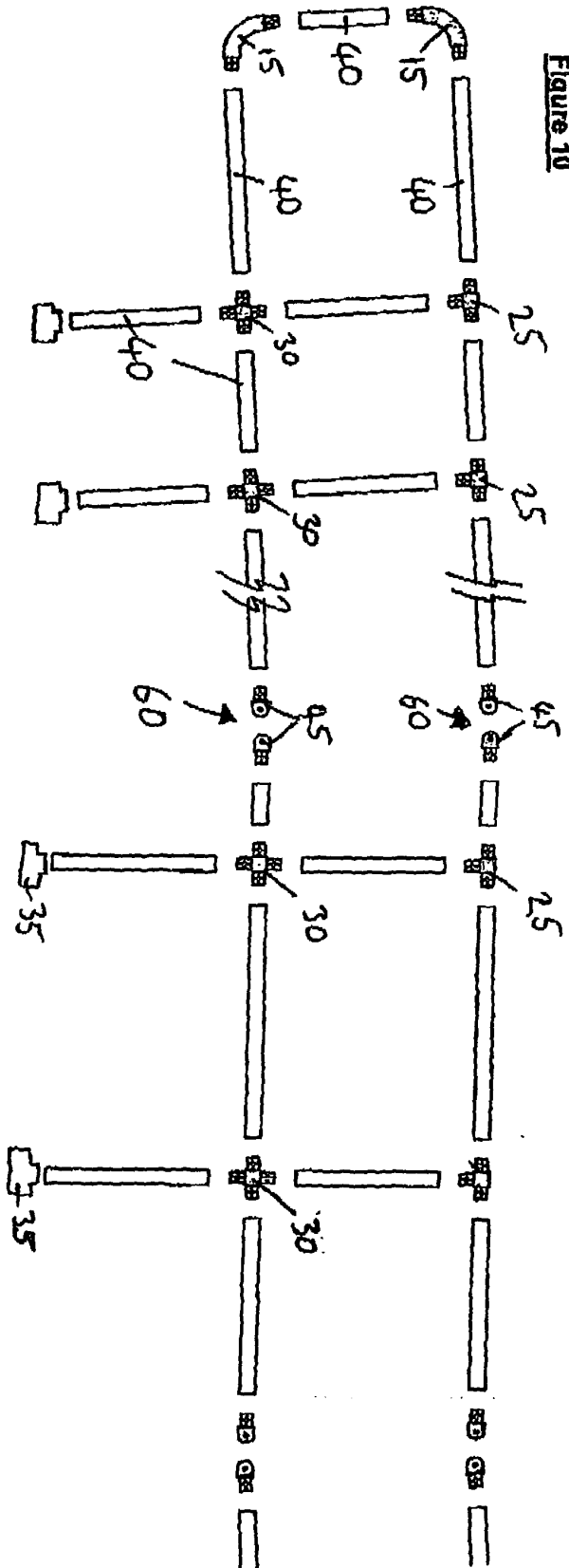

Figure 11

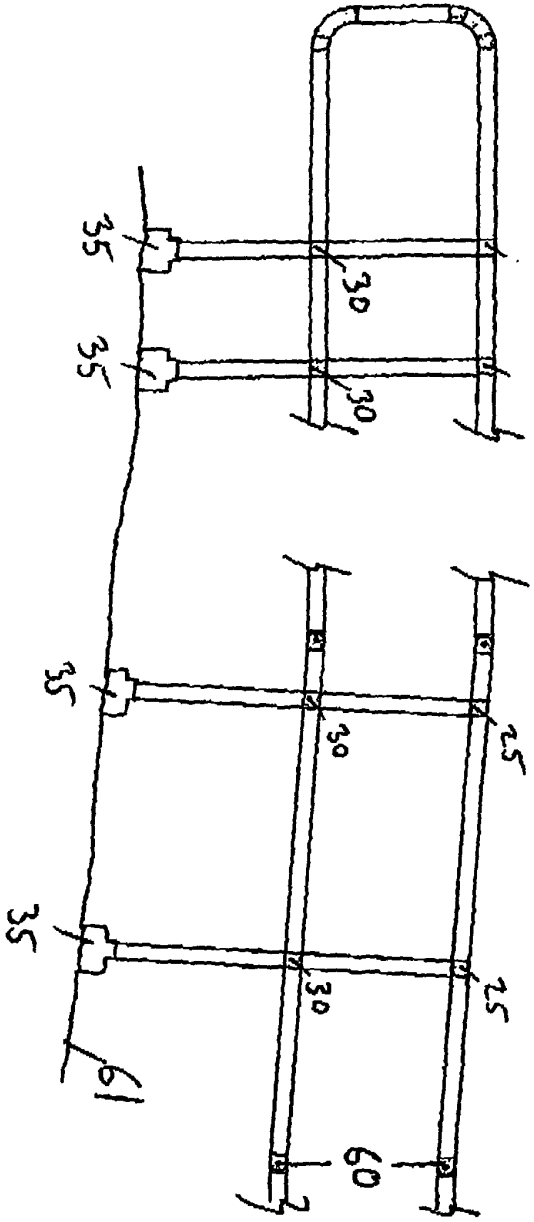

Figure 12

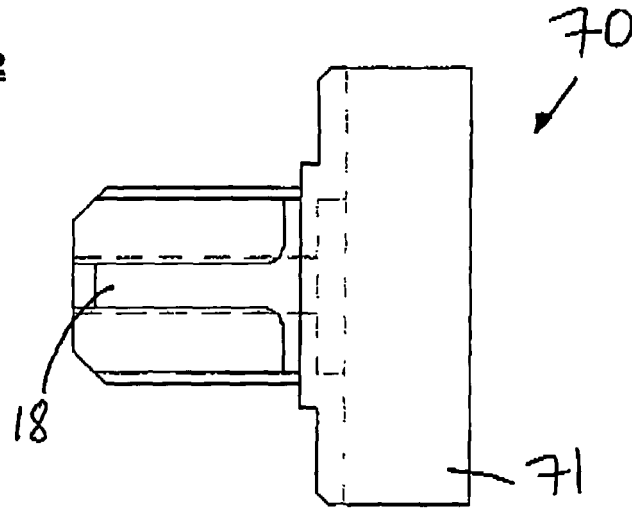

Figure 13

