

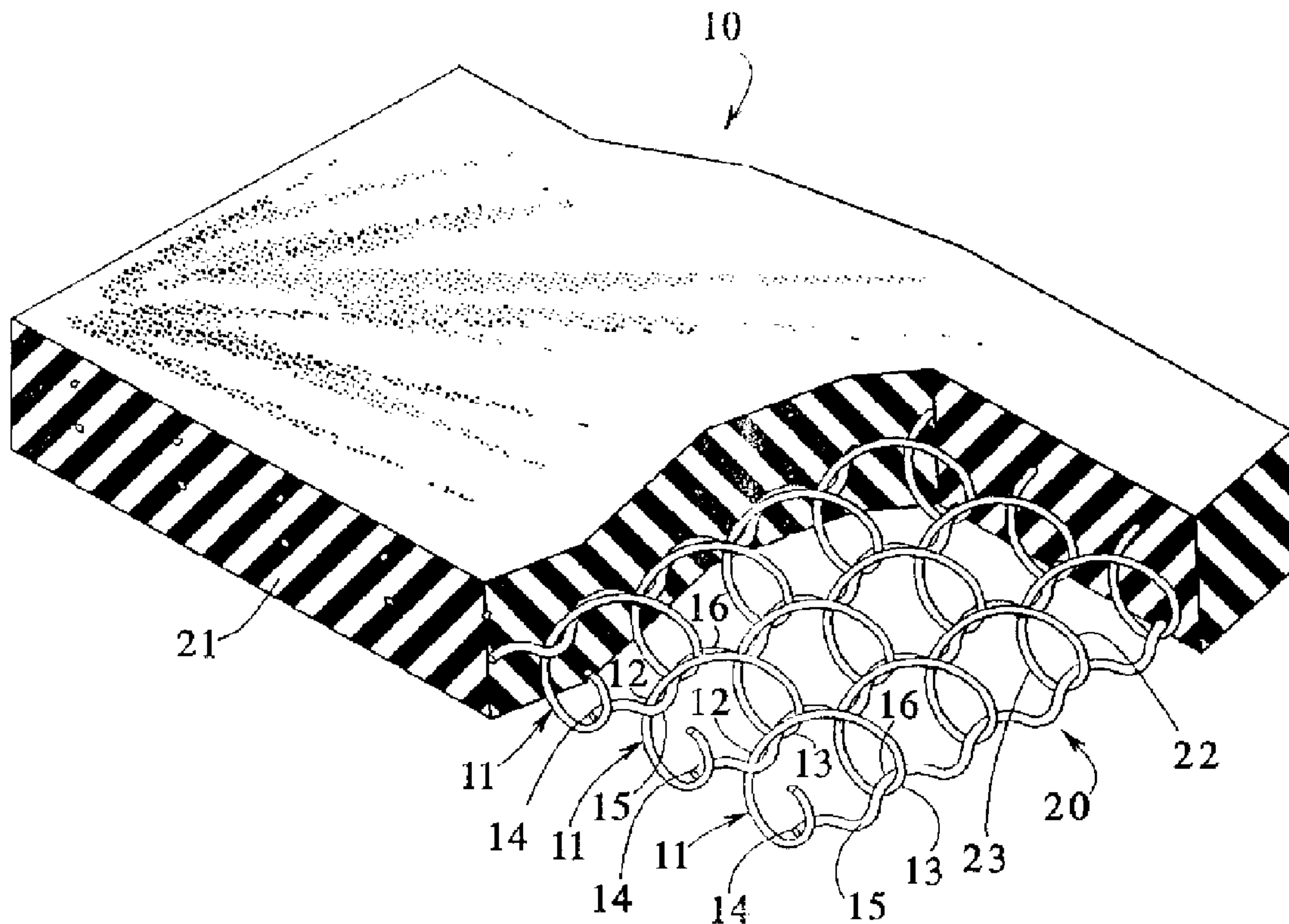

(22) Date de dépôt/Filing Date: 1999/03/16
 (41) Mise à la disp. pub./Open to Public Insp.: 1999/09/25
 (45) Date de délivrance/Issue Date: 2007/06/12
 (30) Priorité/Priority: 1998/03/25 (US09/046,667)

(51) Cl.Int./Int.Cl. *E04C 2/28* (2006.01),
B21F 27/08 (2006.01), *B61D 17/22* (2006.01),
E06B 3/80 (2006.01), *E06B 9/13* (2006.01)
 (72) Inventeurs/Inventors:
 MARKER, WILLIAM C., US;
 KRAFT, KLAUS H., US
 (73) Propriétaire/Owner:
 BURRELL LEDER BELTECH, INC., US
 (74) Agent: SIM & MCBURNEY

(54) Titre : PANNEAUX SOUPLES RESISTANTS AU VANDALISME
 (54) Title: FLEXIBLE VANDAL-RESISTANT PANELS



(57) Abrégé/Abstract:

A strong, flexible and vandalism-resistant panel is provided. The panel includes a flexible wire skeleton structure such as a chain link structure embedded in a layer of polymer material such as rubber, synthetic rubber or another suitable polymer material. The chain link structure is made from parallel flat helical link sections connected by curved cross-sections. The panel of the present invention is particularly useful as a curtain for a roll-up door or for panels used to cover the space disposed between two adjacent railroad car sections. The formed panels are flexible, cannot be dented, are substantially cut-proof and are highly vandalism-resistant.

ABSTRACT OF THE DISCLOSURE

A strong, flexible and vandalism-resistant panel is provided. The panel includes a flexible wire skeleton structure such as a chain link structure embedded in a layer of polymer material such as rubber, synthetic rubber or another suitable polymer material. The chain link structure is made from parallel flat helical link sections connected by curved cross-sections. The panel of the present invention is particularly useful as a curtain for a roll-up door or for panels used to cover the space disposed between two adjacent railroad car sections. The formed panels are flexible, cannot be dented, are substantially cut-proof and are highly vandalism-resistant.

S P E C I F I C A T I O N

TITLE

"FLEXIBLE VANDAL-RESISTANT PANELS"Field of the Invention

The present invention relates generally to flexible panels of construction used for roll-up doors and flexible links connecting to adjacent railroad car sections together. More specifically, the present invention relates to flexible panels that are resistant to cutting and puncturing.

BACKGROUND OF THE INVENTION

Durable, flexible panels are known. Such panels are incorporated into roll-up doors which are typically fabricated from flexible fabric or pivotally connected horizontal metal slats. The roll-up doors fabricated from flexible fabric are undesirable because they are not sufficiently cut-proof or puncture-proof and therefore are susceptible to vandalism.

While the doors made from connected horizontal slats are sufficiently strong, they are relatively expensive to manufacture because of the difficulty in assembling the interconnected horizontal slots. Further, the roll-up doors made from connected horizontal slats are flexible in a horizontal direction only so they can be rolled up onto a horizontal roll disposed at the top of the door opening. However, these types of roll-up doors are not flexible in a direction that extends outward or inward from the plane of the

door. Therefore, these doors are not flexible if an automobile or other structure bumps or engages the door when the door is closed. Often, the metal slots become bent which makes it difficult to extend and retract the door. Further, when one or more of the horizontal slats of the door are sufficiently bent, the entire door or curtain must be replaced.

Another use for a strong material for connecting purposes are vestibule connections for adjoining ends of two railroad car sections. Currently, such vestibule connections are fabricated from accordion-like structures that are a combination of metal frames connected by a webbing that is fabricated from rubber or a combination of rubber and durable fabric. Also, the accordion-like connecting structures can be fabricated entirely from metal.

The currently available vestibule connections suffer from a number of deficiencies. First, if rubber or a fabric material is used to connect the frame components together, the rubber combination of rubber and fabric can be easily cut or damaged by vandals. This is particularly problematic for trains that are transporting valuable commodities, such as luxury automobiles. Typically, in railroad car sections designed exclusively to transport automobiles, the vestibule connection or flexible connection between the railroad cars is the only means of preventing unauthorized entry into the car sections themselves. Accordingly, by fabricating the vestibule connections

from rubber or a combination of rubber and fabric, the vestibule connections and therefore the car sections themselves are susceptible to vandalism and unauthorized entry.

Another disadvantage associated with currently available vestibule connections is reliance upon the use of metal frame members in the accordion-like structure. Any damage to these metal frame members often requires replacement of the entire vestibule connection.

Accordingly, there is a need for an improved flexible and very strong material that is resistant to cutting and puncturing. Such an improved material will lead to improved roll-up type doors as well as to improved vestibule connections or covered connections for adjacent railroad car sections. It is also anticipated that such an improved flexible and durable material would have many other applications as well.

SUMMARY OF THE INVENTION

The present invention satisfies the afore-noted needs by providing an improved, flexible and vandal-resistant panel that is fabricated from a flexible metallic skeleton structure such as woven steel wire cloth, woven stainless steel wire cloth, wire belt material or metallic chain link structures, that is embedded in a layer of polymer material such as natural rubber, synthetic rubber, polyvinyl chloride, polyurethane or other polymer materials.

In an embodiment, the flexible metallic structure comprises a chain link structure comprising a plurality of parallel and adjacent links that are interconnected by a plurality of cross-members. Each link forms a helix having a plurality of flat loops with arcuate end portions that are spaced alternately along opposing first and second sides of the link. Two adjacent links are connected by a cross-member that extends through the arcuate end portions disposed along the first side of one link and the second side of an adjacent link.

In an embodiment, the arcuate end portions of each link are connected by connecting portions that extend between the first and second sides of the link.

In an embodiment, the connecting portions of the links are flat and define a flat front side and a flat rear side of the panel.

In an embodiment, the polymer is natural rubber.

In an embodiment, the polymer is synthetic rubber.

In an embodiment, the polymer is polyvinyl chloride.

In an embodiment, the polymer is polyurethane.

In an embodiment, the polymer is neoprene.

In an embodiment, the flexible panel of the present invention is incorporated into a roll-up door that comprises a flexible panel made in accordance with the present invention and which has an upper end and a lower end. The upper end is connected to a shaft which,

in turn is connected to a pulley mechanism. The pulley mechanism rotates the shaft in a first direction by winding the panel around the shaft and raising the lower end of the panel and the pulley mechanism further rotates the shaft in a second direction for unwinding the panel from the shaft to lower the lower end of the panel.

In an embodiment, a plurality of flexible panels made in accordance with the present invention are used to link two adjacent railroad car sections. Each car section has an end disposed between a first side and a second side as well as a top. The two car sections are spaced apart by a first distance.

In an embodiment, a first side panel is used to link the first sides of the two adjacent car sections. The panel is made in accordance with the present invention as described above. The first panel also has a length that is greater than the first distance thereby providing sufficient slack when the train turns in a direction away from the first sides of the two adjacent car sections. Similarly, a second panel made in accordance with the present invention as described above is used to link the second sides of the adjacent car sections. Again, the second panel has a length that is greater than the first distance which provides sufficient slack when the train turns in a direction away from the second sides of the two adjacent car sections. A top panel, also made in accordance with the

present invention, is used to link the tops of the adjacent car sections. Preferably, the top panel also is provided with sufficient slack for turning. As a result, three panels are used to couple or link two adjacent railroad car sections. The panels are strong, durable and cut-proof thereby providing the requisite resistance to vandalism.

In an embodiment, the vestibule connection provided by the present invention includes a top panel and opposing first and second side panels as discussed above. However, the top panel is linked to the first and second opposing side panels by a plurality of shingled sections that are connected together in an end-to-end fashion.

In an embodiment, the top panel and first and second opposing side panels each include an accordion-like structure to provide the slack that is necessary when the train turns.

In an embodiment, the shingled sections have an accordion-like structure to provide the necessary slack between two adjoining car sections.

In an embodiment, the present invention provides a method of fabricating a flexible and vandal-resistant panel. The method comprises the steps of providing a plurality of links, each link comprising a flat helix comprising a plurality of flat loops with arcuate end portions spaced alternately along opposing first and second sides of the link. The method also comprises the step of

providing a plurality of cross-members and connecting the first side of each link to a second side of a preceding link by inserting a cross-member between the links so that the cross-member extends through the arcuate end portions disposed along the first side of each link and the second side of the preceding link. Further, the method includes the steps of connecting the second side of each link to a first side of a succeeding link by inserting a cross-member between the links so that the cross-member extends through the arcuate end portions disposed along the second side of said each link and the first side of the succeeding link. Finally, the method includes the steps of embedding the connected links or chain link structure in a layer of polymer material.

It is therefore an advantage of the present invention to provide an improved flexible panel which is cut-proof and vandalism-resistant.

Another advantage of the present invention is that it provides an improved flexible panel that cannot be dented.

Yet another advantage of the present invention is that it provides an improved vandalism-proof connecting vestibule for adjacent railroad car sections.

Yet another advantage of the present invention is that it provides an improved curtain for a roll-up door which is vandalism-resistant and which cannot be dented during use.

Still another advantage of the present invention is that it provides an improved method of fabricating flexible, cut-proof and vandalism-resistant panels or curtains.

According to one aspect of the present invention, there is provided a flexible connection system for linking two adjacent railroad car sections, the adjacent car sections being spaced apart by a first distance, each railroad car section having an end disposed between a first side and a second side, each car section further having a top, the connection system comprising:

a first side panel linking the first sides of the adjacent car sections, the first side panel having a length that is greater than the first distance,

a second side panel linking the second sides of the adjacent car sections, the second side panel having a length that is greater than the first distance,

a top panel linking the tops of the adjacent car sections, the top having a length that is greater than the first distance,

each of said first side, second side and top panels being fabricated from a material comprising a flexible wire skeleton structure embedded in layer of a polymer material, the wire skeleton structure comprising a plurality of parallel and adjacent links interconnected by a plurality of cross members and embedded in a layer of polymer material,

each link forming a helix comprising a plurality of flat loops with arcuate end portions spaced alternately along opposing first and second sides of the link,

two adjacent links being connected to each other by a cross member that extends through the arcuate end portions disposed along the first side of one link and the second side of an adjacent link.

According to another aspect of the present invention, there is provided a method of providing a flexible and vandal resistant connection system for adjacent first and second railroad car sections having a substantially same height, the first and second car sections being spaced apart by a first distance, each railroad car section having an end disposed between a first side and a second side, each car section further having a top, the connection system comprising:

8a

connecting the first side of the first car section to the first side of the second car section with a first side panel, the first side panel having a length that is greater than the first distance, the first side panel being flexible and extending substantially along the height of the first and second car sections,

connecting the second side of the first car section to the second side of the section car section with a second side panel, the second side panel having a length that is greater than the first distance,

connecting the top of the first car section to the top of the second car section with a top panel, the top panel having a length that is greater than the first distance,

wherein each of said first side, second side and top panels being fabricated from a material comprising a plurality of parallel and adjacent links interconnected by a plurality of cross members and embedded in a layer of a polymer material,

each link forming a helix comprising a plurality of flat loops with arcuate ends portions spaced alternately along opposing first and second sides of the link,

two adjacent links being connected to each other by a cross member that extends through the arcuate end portions disposed along the first side of one link and the second side of an adjacent link.

Other objects and advantages of the invention will become apparent upon reading the following detailed description and appended claims, and upon reference to the accompanying drawings.

BRIEF DESCRIPTION OF THE DRAWINGS

For a more complete understanding of the present invention, reference should now be made to the embodiments illustrated in greater detail in the accompanying drawings and described below by way of examples of the invention.

In the drawings:

Figure 1 is a partial perspective view of a panel made in accordance with the present invention;

Figure 2 is a plan view of the chain link structure of the panel shown in Figure 1;

8b

Figure 3 is a perspective view of a roll-up door made with the flexible panel or curtain of the present invention;

Figure 4 is a partial perspective view of a vestibule connection for two adjacent railroad car sections made in accordance with the present invention;

Figure 5 is a partial perspective view illustrating a vestibule connection made in accordance with an alternative embodiment of the

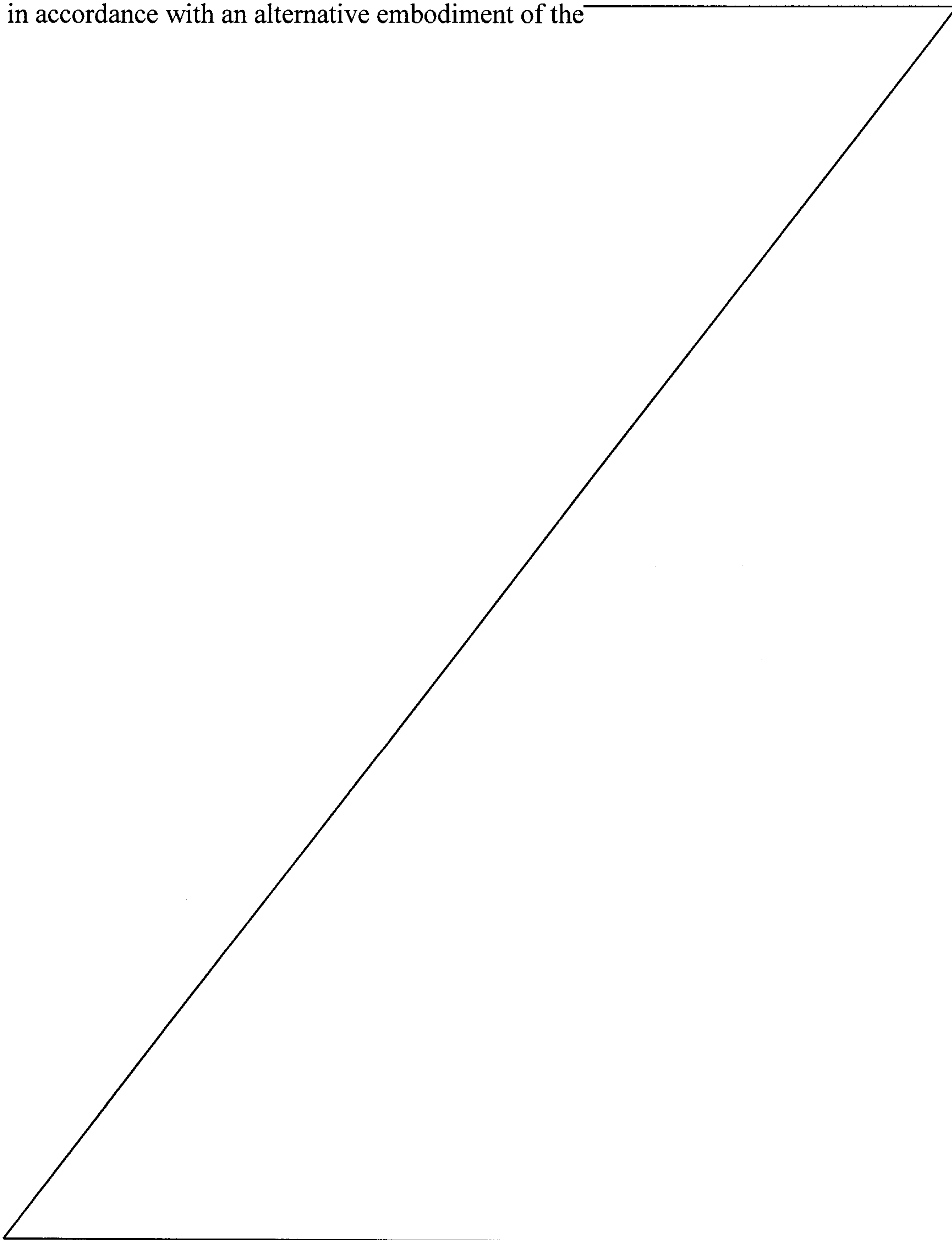

present invention; and

Figure 6 is an enlarged perspective view of a connection between a shingled panel section and a side panel section as shown in Figure 5.

From the above description it is apparent that the objects of the present invention have been achieved. While only certain embodiments have been set forth, alternative embodiments and various modifications will be apparent from the above description to those skilled in the art. These and other alternatives are considered equivalents and within the spirit and scope of the present invention.

DESCRIPTION OF THE PRESENTLY PREFERRED EMBODIMENTS

Turning first to Figure 1, a partial section of a flexible panel or curtain 10 is illustrated. The panel 10 includes a plurality of parallel and adjacent links 11. Each link is a helical coil having arcuate end portions 12, 13 disposed on opposing first and second sides of each coil 11 respectively. A plurality of parallel and adjacent cross-members 14 are also provided which connect adjacent links 11 together. Specifically, as shown in Figure 1, a cross-member 14 connects the arcuate end portions 12 of a first side of a link 11 to the arcuate end portions 13 of a second side of an adjacent link 11. Preferably, the cross-members 14 include inward and outward curve portions 15 and 16 for this purpose. That is, the curve portions 15 loop around the arcuate end portions 12 of the

first sides of the links 11 and the curved portions 16 loop around the arcuate end portions 13 of the second side of the links 11. In this way, the panel or curtain 10 is provided with a reinforcing skeleton structure 20, such as the chain link structure shown in Figures 1 and 2. The skeleton chain link structure 20 is then embedded in a layer of rubber or other suitable polymer material 21. As an alternative, the polymer material 21 may also be fabricated from NEOPRENE[™] synthetic rubber.

It will also be noted that the links 11 also include upper and lower connecting portions 22, 23. In a preferred embodiment, the links form a flat helix and therefore the connecting portions 22, 23 are relatively straight and define flat front and rear sides to the panel 10.

As illustrated in Figure 2, the shape of the helix of the links 11 can vary. However, the upper and lower connecting portions 22, 23 should have a relatively straight configuration to provide flat front and rear surfaces to the panel 10.

As illustrated in Figure 3, a panel 10a can be incorporated into a roll-up type door system 30. Due to the flexibility of the panel 10a, it can be wound upon a shaft (not shown) and raised and lowered by a pulley system like the one shown schematically at 31. The roll-up type door 30 provides a substantial improvement over existing roll-up doors because the panel or curtain 10a cannot be dented or

bent. It is too flexible. Engagement by an automobile or other vehicle will not dent the panel 10a but will merely cause it to flex. The panel 10a is also substantially cut-proof and therefore is highly vandalism resistant. It is also anticipated that the polymer layer 21 could be provided in a variety of colors, including black, white and other colors to improve the esthetic appearance of the door 30.

As shown in Figure 4, three panels 10b, 10c and 10d can be used to provide a vestibule-type connection 40 between adjacent railroad car sections 41, 42. Specifically, a panel 10b can be used to connect adjacent first sides of the two car sections 41, 42. A panel 10c can be used to connect adjoining top sides of the adjacent car sections 41, 42. Further, a panel 10d can be used to connect adjacent second sides of the car sections 41, 42. It will be noted from Figure 4 that each of the panels 10b, 10c and 10d have a length that is greater than the spacing distance between the two car sections 41, 42. This additional link provides sufficient slack in the panels which is needed when the railroad car sections make a turn in a direction opposite or away from the side on which the panels are located. Further, the side panels 10d (and 10b) can be extended downward towards the bottoms 43, 44 of the sides 45, 46 respectively. In this manner, the combination of the side panels 10b and 10d, along with the top panel 10c, provide a secure and near vandalism-proof cover for the space disposed between the two adjoining car sections

41, 42. In the event the cars 41, 42 are carrying expensive cargo, such as automobiles or luxury automobiles, the vandalism preventing characteristics of the present invention become very important.

In another embodiment, a vestibule connection 50 is provided which includes a plurality of panels having a corrugated or accordion-like configuration. Specifically, the connection 50 shown in Figure 5 includes a top panel 51 disposed between opposing first and second side panels 52, 53. However, in contrast to the configuration shown in Figure 4, the top panel 51 is connected to the side panels 52, 53 by a plurality of shingled sections shown at 54. The corrugated structure of the panels 51-54 provides the necessary slack required between the two adjacent car sections 55, 56.

It should be understood that the drawings are not necessarily to scale and that the embodiments are sometimes illustrated by graphic symbols, phantom lines, diagrammatic representations and fragmentary views. In certain instances, details which are not necessary for an understanding of the present invention or which render other details difficult to perceive may have been omitted. It should be understood, of course, that the invention is not necessarily limited to the particular embodiments illustrated herein.

WHAT WE CLAIM IS:

1. A flexible connection system for linking two adjacent railroad car sections, the adjacent car sections being spaced apart by a first distance, each railroad car section having an end disposed between a first side and a second side, each car section further having a top, the connection system comprising:

a first side panel linking the first sides of the adjacent car sections, the first side panel having a length that is greater than the first distance,

a second side panel linking the second sides of the adjacent car sections, the second side panel having a length that is greater than the first distance,

a top panel linking the tops of the adjacent car sections, the top having a length that is greater than the first distance,

each of said first side, second side and top panels being fabricated from a material comprising a flexible wire skeleton structure embedded in layer of a polymer material, the wire skeleton structure comprising a plurality of parallel and adjacent links interconnected by a plurality of cross members and embedded in a layer of polymer material,

each link forming a helix comprising a plurality of flat loops with arcuate ends portions spaced alternately along opposing first and second sides of the link,

two adjacent links being connected to each other by a cross member that extends through the arcuate end portions disposed along the first side of one link and the second side of an adjacent link.

2. The connection system of claim 1, wherein the skeleton structure of each panel has corrugated configuration.

3. The connection system of claim 2, wherein the arcuate end portions each link are connected by portions that extend between the first and second ends of the link.

4. The connection system of claim 3, wherein the connecting portions of the links define a flat front side and a flat rear side of each of said panels.
5. The connection system of claim 2, wherein each cross-member comprises alternating first and second curved portions, the first curved portions looping around the arcuate end portions at the first side of one of said links, the second curved portion looping around the arcuate end portion of the second side of one of said links.
6. The connection system of claim 1, wherein the polymer is selected from the group consisting of natural rubber, synthetic rubber, polyvinyl chloride and polyurethane.
7. A method of providing a flexible and vandal resistant connection system for adjacent first and second railroad car sections having a substantially same height, the first and second car sections being spaced apart by a first distance, each railroad car section having an end disposed between a first side and a second side, each car section further having a top, the connection system comprising:
 - connecting the first side of the first car section to the first side of the second car section with a first side panel, the first side panel having a length that is greater than the first distance, the first side panel being flexible and extending substantially along the height of the first and second car sections,
 - connecting the second side of the first car section to the second side of the second car section with a second side panel, the second side panel having a length that is greater than the first distance,
 - connecting the top of the first car section to the top of the second car section with a top panel, the top panel having a length that is greater than the first distance,
 - wherein each of said first side, second side and top panels being fabricated from a material comprising a plurality of parallel and adjacent links interconnected by a plurality of cross members and embedded in a layer of a polymer material,

each link forming a helix comprising a plurality of flat loops with arcuate ends portions spaced alternately along opposing first and second sides of the link,

two adjacent links being connected to each other by a cross member that extends through the arcuate end portions disposed along the first side of one link and the second side of an adjacent link.

8. The method of claim 7, wherein the arcuate end portions each link are connected by connecting portions that extend between the first and second ends of the link, the connecting portions of the links define a flat front side and a flat rear side of each of said panels, and wherein each cross-member comprises alternating first and second curved portions, the first curved portions looping around the arcuate end portion at the first side of one of said links, the second curved portion looping around the arcuate end portion of the second side of one of said links.

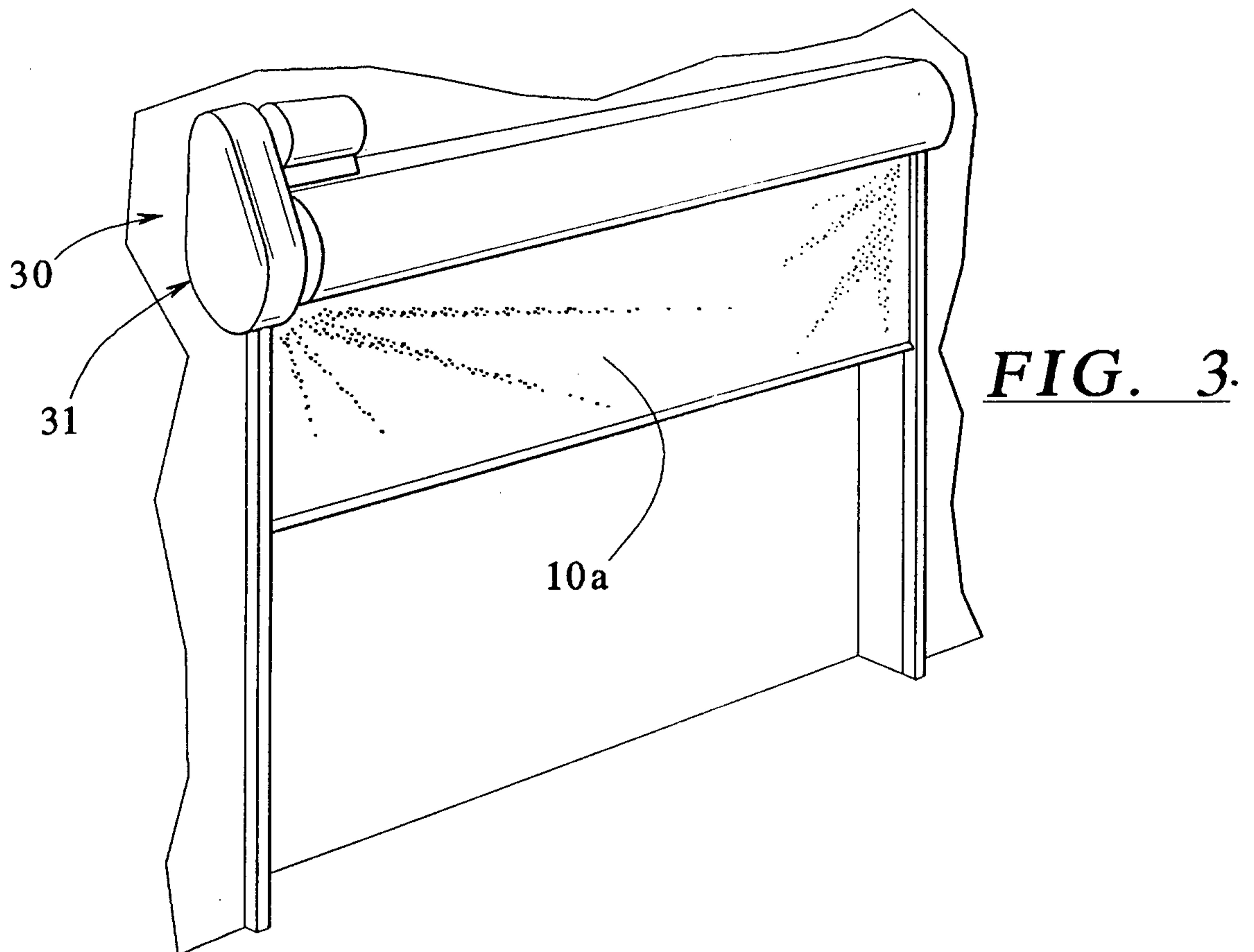
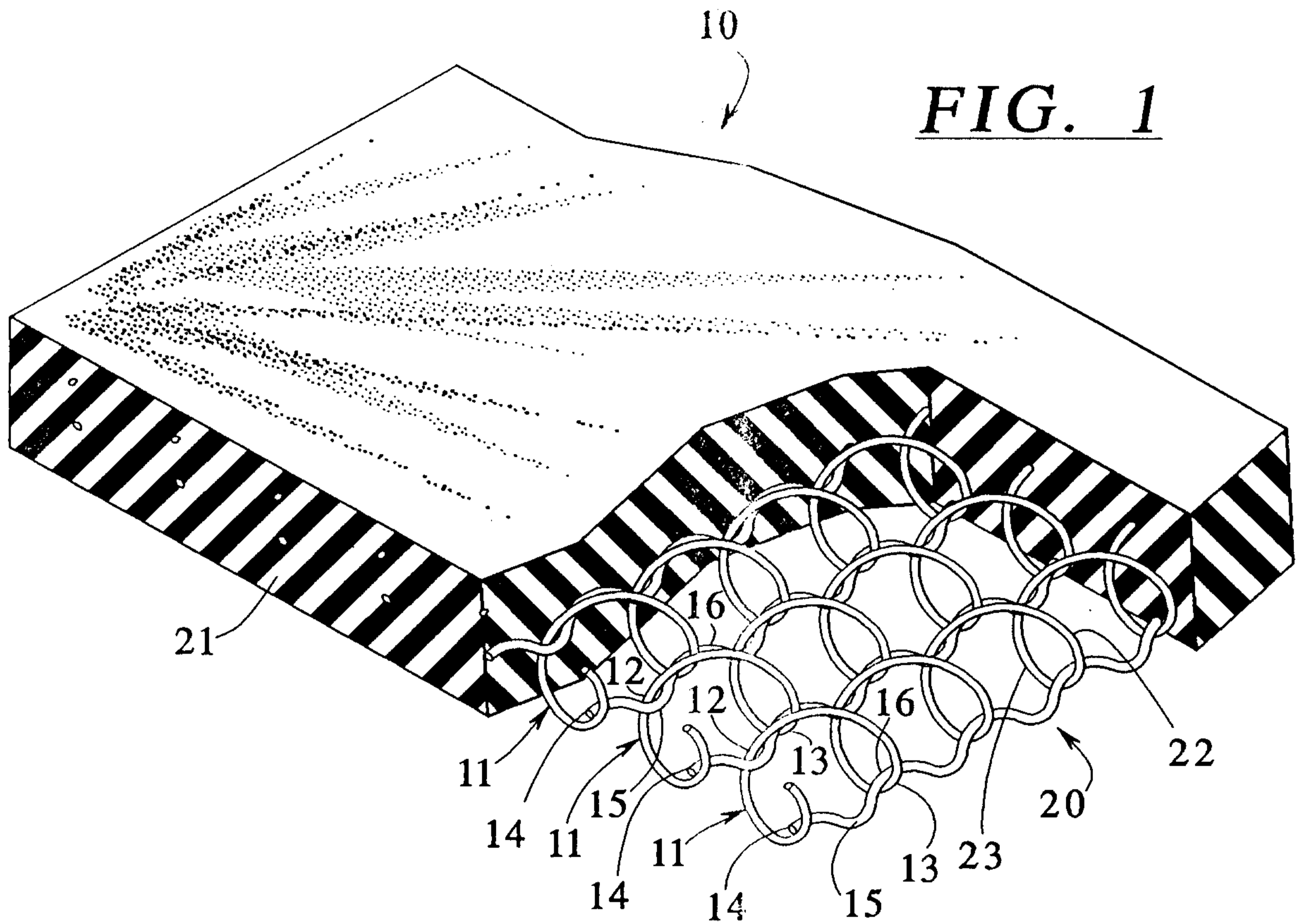

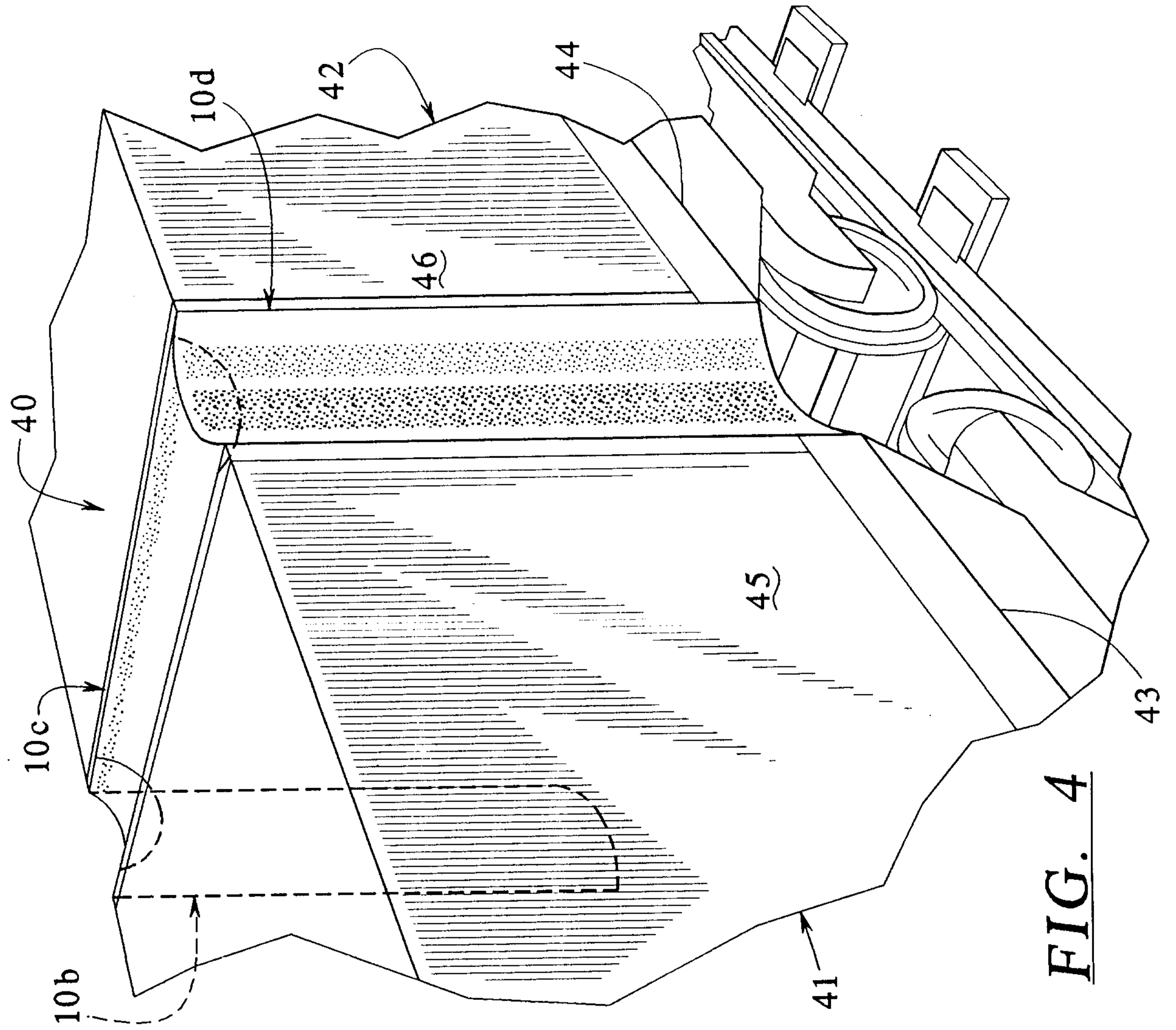
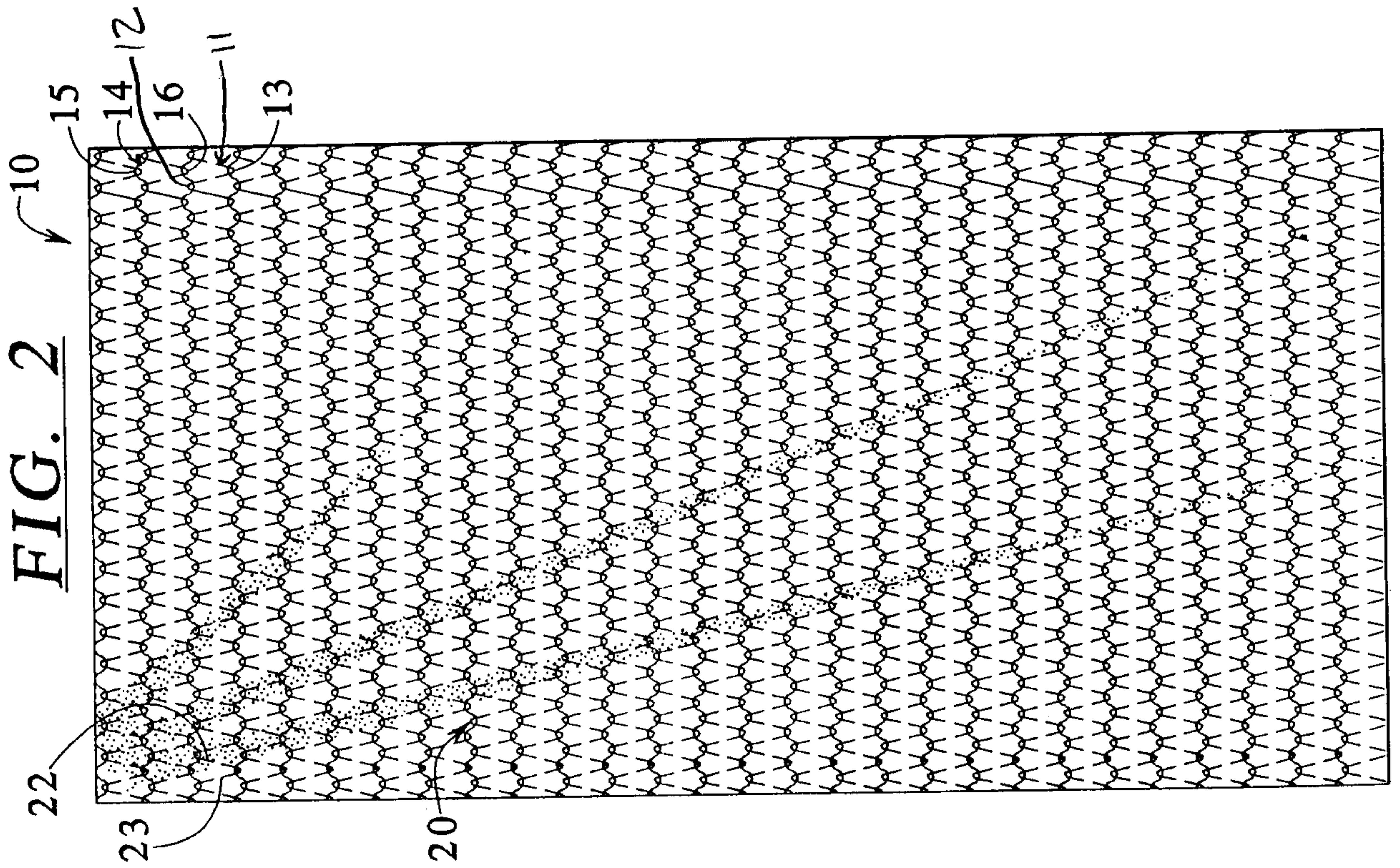

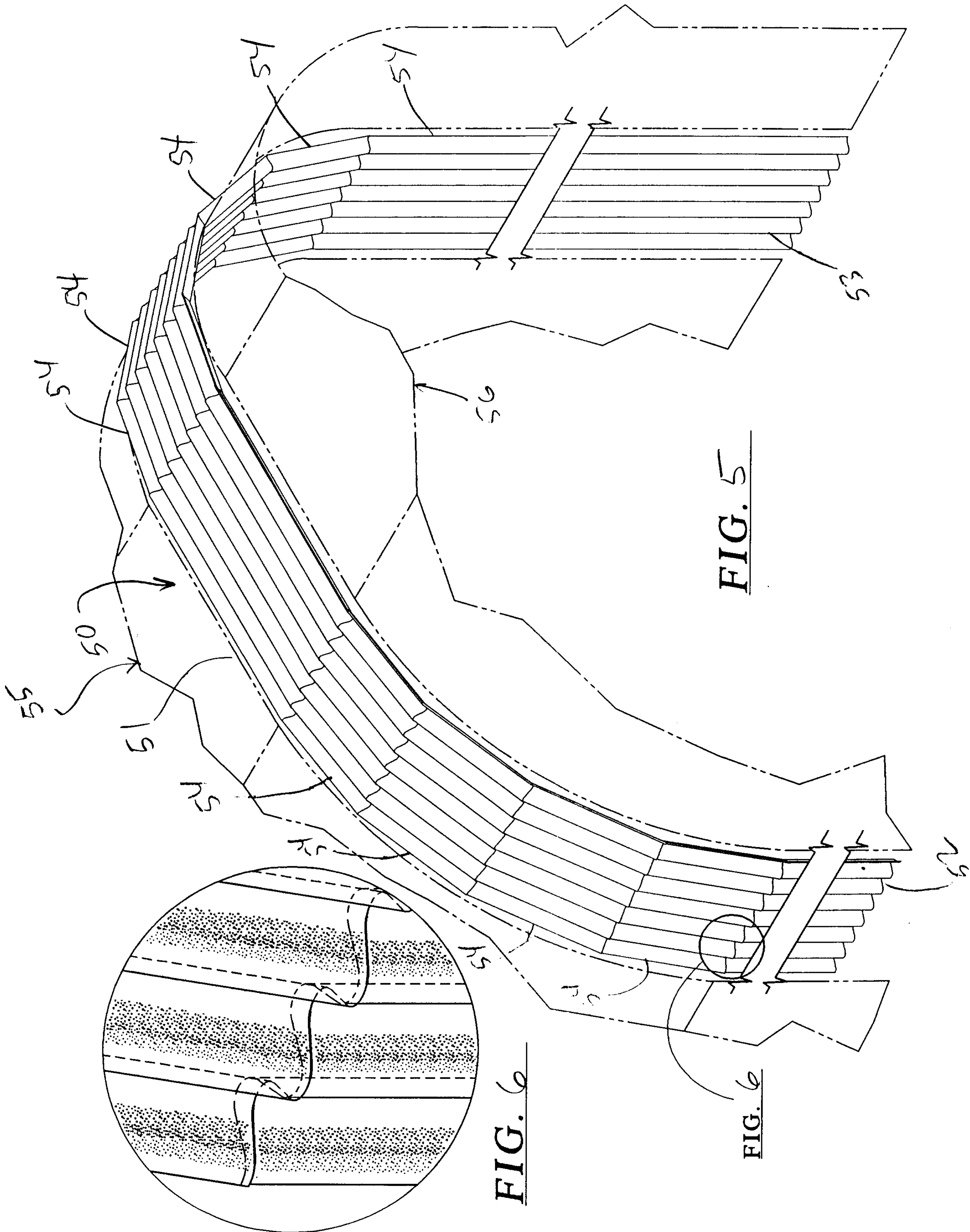

FIG. 5

FIG. 6

FIG. 6

