



US00RE45938E

(19) **United States**
(12) **Reissued Patent**
Arthun

(10) **Patent Number:** **US RE45,938 E**
(45) **Date of Reissued Patent:** ***Mar. 22, 2016**

(54) **SEALING APPLIANCE**

(75) Inventors: **Nils Arthun**, Sandnes (NO); **Liv Arthun**, legal representative, Hönö (SE)

(73) Assignee: **Merck Chemicals and Life Science AB**, Solna (SE)

(*) Notice: This patent is subject to a terminal disclaimer.

(21) Appl. No.: **13/613,658**

(22) Filed: **Sep. 13, 2012**

Related U.S. Patent Documents

Reissue of:

(64) Patent No.: **6,779,575**
Issued: **Aug. 24, 2004**
Appl. No.: **09/701,459**
PCT Filed: **May 25, 1999**
PCT No.: **PCT/SE99/00878**
§ 371 (c)(1), (2), (4) Date: **Dec. 4, 2000**
PCT Pub. No.: **WO99/64837**
PCT Pub. Date: **Dec. 16, 1999**

U.S. Applications:

(60) Continuation of application No. 12/422,820, filed on Apr. 13, 2009, which is a division of application No. 11/305,813, filed on Dec. 19, 2005, now Pat. No. Re. 41,169, which is an application for the reissue of Pat. No. 6,779,575, filed as application No. PCT/SE99/00878 on May 25, 1999.

(30) **Foreign Application Priority Data**

May 28, 1998 (SE) 9801885

(51) **Int. Cl.**
B29C 65/00 (2006.01)
A61M 39/14 (2006.01)

(52) **U.S. Cl.**
CPC **B29C 66/857** (2013.01); **A61M 39/146** (2013.01)

(58) **Field of Classification Search**

USPC 156/515, 530, 579, 580, 581, 250, 257;
100/94, 98 R; 72/307, 325, 370.12,
72/409.1, 409.5, 409.19, 461, 702; 29/282
See application file for complete search history.

(56) **References Cited**

U.S. PATENT DOCUMENTS

2,776,473 A 1/1957 Dailey et al.
3,175,556 A 3/1965 Wood et al.

(Continued)

FOREIGN PATENT DOCUMENTS

EP 0508474 10/1992 B29C 65/20
EP 0508474 A2 10/1992

(Continued)

OTHER PUBLICATIONS

Office Action mailed Sep. 20, 2012 in corresponding U.S. Appl. No. 12/422,820.

(Continued)

Primary Examiner — George Koch

(74) *Attorney, Agent, or Firm* — Hamilton, Brook, Smith & Reynolds, P.C.

(57) **ABSTRACT**

An appliance for sealing elastic hoses with a sleeve, which is plastically deformable and slipped onto the hose, has two jaws which are movable towards and away from each other. One jaw has two straight bars which project towards the other jaw and extend transversely of the sleeve to make two transverse indentations in the sleeve and the hose when the jaws are moving towards each other. The same jaw has a cutting edge which projects towards the other jaw and is directed transversely of the sleeve, the cutting edge making a substantially transverse cutting indication in the sleeve and the hose when the jaws are moving towards each other.

28 Claims, 5 Drawing Sheets

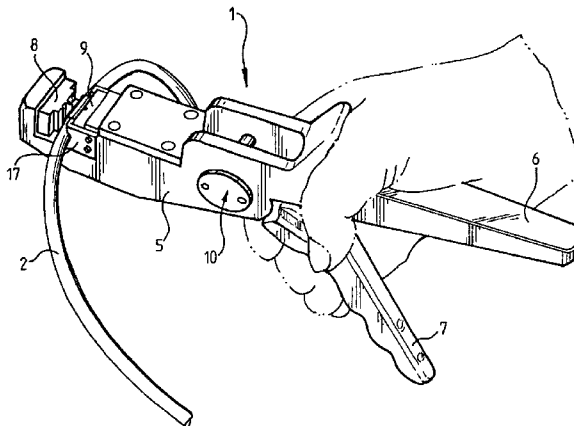

(56)

References Cited

U.S. PATENT DOCUMENTS

3,263,465	A	8/1966	Way et al.	
3,276,447	A	10/1966	Hamilton	
3,523,351	A	8/1970	Filia	
3,576,122	A	4/1971	Churla	
3,931,671	A	1/1976	Dittmann	
4,026,294	A	5/1977	Mattler	
4,428,374	A	1/1984	Auburn	
4,625,494	A	12/1986	Iwatschenko et al.	
4,637,242	A *	1/1987	Undin et al.	72/410
5,105,648	A	4/1992	Steiner et al.	
5,131,213	A	7/1992	Shanklin et al.	
5,236,331	A	8/1993	Liu	
5,509,291	A	4/1996	Nilsson et al.	
5,520,218	A	5/1996	Hlavinka et al.	
5,584,840	A	12/1996	Ramsey et al.	
5,649,444	A	7/1997	Nilsson et al.	
5,711,078	A *	1/1998	Patton et al.	30/228
5,732,530	A *	3/1998	Pfaff	53/403
5,768,935	A *	6/1998	Owens	72/416
5,775,158	A *	7/1998	Hensley et al.	30/180
5,968,054	A	10/1999	Yeatts, II et al.	
6,230,781	B1	5/2001	Smith	
6,779,575	B1	8/2004	Arthun	
RE41,169	E	3/2010	Arthun	
7,959,754	B2	6/2011	Arthun	
2008/0149503	A1	6/2008	Pandori	
2011/0197426	A1	8/2011	Arthun	

FOREIGN PATENT DOCUMENTS

WO	97/16715	A1	5/1997	
WO	97/16715		5/1997	G01N 1/10
WO	99/64837	A1	12/1999	

OTHER PUBLICATIONS

Case 2:05-cv-05175-DMC-MF, Document 35, US District Court for the District of New Jersey, Filed Jun. 3, 2010; 37-Pages; "Gore's Memorandum in Opposition to Millipore's Motion to Reopen The Action and for Contempt and Millipore's Motion to Substitute".

Case 2:05-cv-05175-DMC-MF, Document 23-1, US District Court for the District of New Jersey, Filed May 12, 2010; 22-Pages; "Memorandum in Support of Motion to Reopen the Action for the Limited Purpose of Enforcing the Consent Judgment Order and for Contempt Against W.L. Gore & Associates, Inc.".

Case 2:05-cv-05175-DMC-MF, Document 43, US District Court for the District of New Jersey, Filed Jun. 14, 2010; 23-Pages; "Plaintiffs' Reply to Defendant's Opposition to Motion to Reopen the Action for the Limited Purpose of Enforcing the Consent Judgment Order and for Contempt Against W.L. Gore & Associates, Inc.".

Civil Action No. 2:11-cv-01453-ES-CLW, US District Court for the District of New Jersey, Gore's Invalidity Contentions, dated May 25, 2012, 20 pages.

Civil Action No. 2:11-cv-01453-ES-CLW, US District Court for the District of New Jersey, Gore's Invalidity Contentions, dated May 25, 2012, Exhibit A, 35 pages.

Civil Action No. 2:11-cv-01453-ES-CLW, US District Court for the District of New Jersey, Gore's Invalidity Contentions, dated May 25, 2012, Exhibit B, 38 pages.

Civil Action No. 2:11-cv-01453-ES-CLW, US District Court for the District of New Jersey, Gore's Invalidity Contentions, dated May 25, 2012, Exhibit C, 33 pages.

Civil Action No. 2:11-cv-01453-ES-CLW, US District Court for the District of New Jersey, Gore's Invalidity Contentions, dated May 25, 2012, Exhibit D, 37 pages.

Office Action dated Mar. 10, 2010 in corresponding U.S. Appl. No. 12/422,820.

Final Rejection dated Nov. 16, 2010 in corresponding U.S. Appl. No. 12/422,820.

Office Action mailed Aug. 10, 2011 in corresponding U.S. Appl. No. 12/422,820.

Notice of Allowance mailed Apr. 11, 2012 in corresponding U.S. Appl. No. 12/422,820.

Final Rejection mailed Apr. 16, 2013 in corresponding U.S. Appl. No. 12/422,820.

Office Action mailed Mar. 20, 2013 in corresponding U.S. Appl. No. 13/613,669.

Office Action mailed Mar. 19, 2013 in corresponding U.S. Appl. No. 13/536,199.

International Search Report mailed Sep. 7, 1999 in PCT application No. PCT/SE99/00878.

International Preliminary Exam Report mailed Sep. 26, 2000 in PCT application No. PCT/SE99/00878.

Civil Action No. 2:05-05175 (DMC/MF), USDC for the District of New Jersey, "Consent Judgment Order", Document 22, Filed Feb. 28, 2007, 5 pages.

Civil Action No. 2:05-05175 (DMC/MF), USDC for the District of New Jersey, "Opinion" (granting substitution of parties, denying motion for contempt), Document 50, Filed Dec. 29, 2010, 13 pages.

Civil Action No. 2:05-05175 (DMC/MF), USDC for the District of New Jersey, "Exhibit A, Exhibit B, Exhibit C", Exhibits referenced in Document 50, Filed Dec. 29, 2010, 3 pages.

Civil Action No. 2:11-cv-01453-DMC-JAD, USDC for the District of New Jersey, "Memorandum of Law in Support of application For Preliminary Injunction", Document-4-1, Filed Mar. 15, 2011, 26 pages.

Civil Action No. 2:11-cv-01453-DMC-JAD, USDC for the District of New Jersey, "Gore's Opposition to Millipore's Application for Preliminary Injunction", Document 20, Filed Apr. 15, 2011, 37 pages.

Civil Action No. 2:11-cv-01453-DMC-JAD, USDC for the District of New Jersey, "Expert Report of James Dean Vogel", Document 20-9, Filed Apr. 15, 2011, 14 pages.

Civil Action No. 2:11-cv-01453-DMC-JAD, USDC for the District of New Jersey, "Millipore's Reply to Gore's Opposition to Application for Preliminary Injunction", Document 21, Filed Apr. 27, 2011, 17 pages.

Civil Action No. 2:11-cv-01453-DMC-JAD, USDC for the District of New Jersey, "Supplemental Declaration of Samir Nayfeh", Document 21-1, Filed Apr. 27, 2011, 17 pages.

Civil Action No. 2:11-cv-01453-ES-CLW, USDC for the District of New Jersey, "Opinion" (denying Motion for Preliminary Injunction), Document 33, Filed Nov. 9, 2011, 26 pages.

Civil Action No. 2:11-cv-01453-DMC-JAD, USDC for the District of New Jersey, "Disclosure of Asserted Claims and Infringement Contentions", Filed Jun. 30, 2011, 40 pages.

Civil Action No. 2:11-cv-01453-ES-CLW, USDC for the District of New Jersey, "Gore's Non-Infringement Contentions and Responses to Millipore's Infringement Contentions", Filed Aug. 15, 2011, 26 pages.

Civil Action No. 2:11-cv-01453-ES-CLW, USDC for the District of New Jersey, "Gore's Response Claim Construction Brief", Document 42, Filed Feb. 8, 2012, 32 pages.

Civil Action No. 2:11-cv-01453-ES-CLW, USDC for the District of New Jersey, "Millipore's Responding Markman Brief", Document 43, Filed Feb. 8, 2012, 29 pages.

Civil Action No. 2:11-cv-01453-ES-CLW, USDC for the District of New Jersey, Relevant pages of W.L. Gore & Associates, Inc.'s Answers to Millipore's Second Set of Interrogatories (Interrogatory Nos. 10-12), Served Jul. 2, 2012, 7 pages.

Civil Action No. 2:11-cv01-01453-ES-CLW, USDC for the District of New Jersey, "Opinion" (on claim construction), Civil Action 82, Dated Oct. 24, 2012, 22 pages.

Civil Action No. 2:11-cv-01453-ES-CLW, USDC for the District of New Jersey, Relevant page of "Pull-off test post cut, half inch and three quarter-tubing size Test protocol", bearing Bates No. MNJ0296286, Oct. 31, 2006, 1 page.

Civil Action No. 2:11-cv-01453-ES-CLW, USDC for the District of New Jersey, Relevant page of "Use-life integrity test post cut Novaseal quarter and half inch tubing size Test protocol", bearing Bates No. MNJ0311874, Jan. 25, 2007, 1 page.

Civil Action No. 2:11-cv-01453-ES-CLW, USDC for the District of New Jersey, "Statement of Use under 37 CFR 2.88 with Declaration"

(56)

References Cited

OTHER PUBLICATIONS

from U.S. Trademark application 75/066,270, executed Jan. 27, 1998, bearing Bares Nos. WLG-NJ00053431-32, 2 pages.

Civil Action No. 2:11-cv-01453-ES-SCM, USDC for the District of New Jersey, "Stipulated Order of Dismissal With Prejudice", Document 86, Issued Jun. 10, 2013 and Filed Jun. 13, 2013, 2 pages.

* cited by examiner

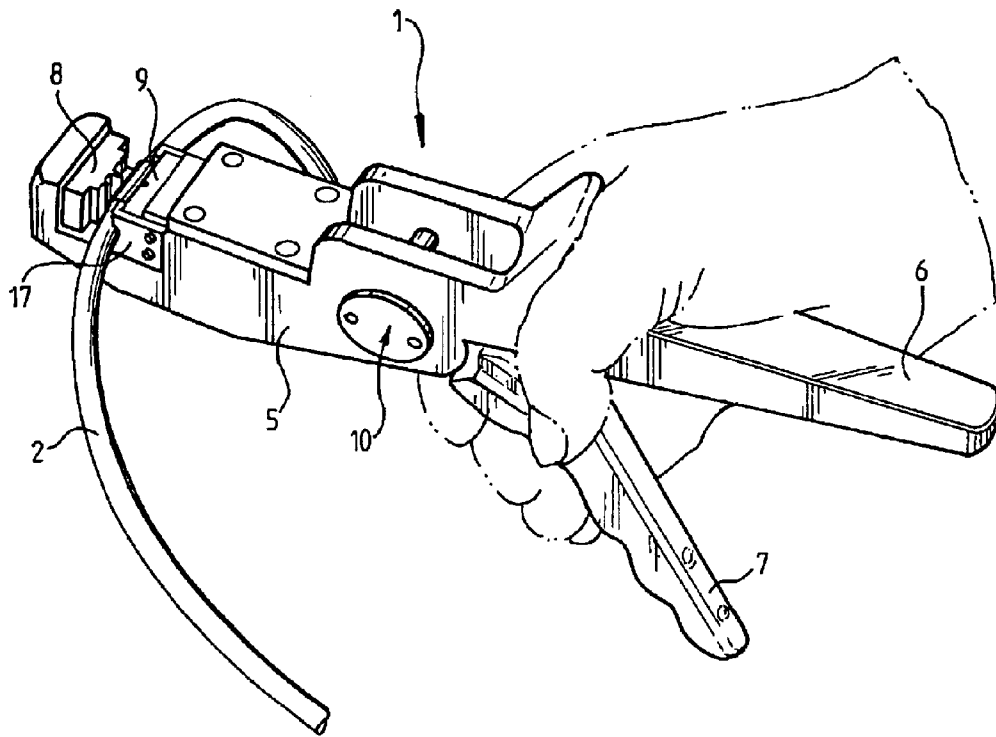

Fig. 1

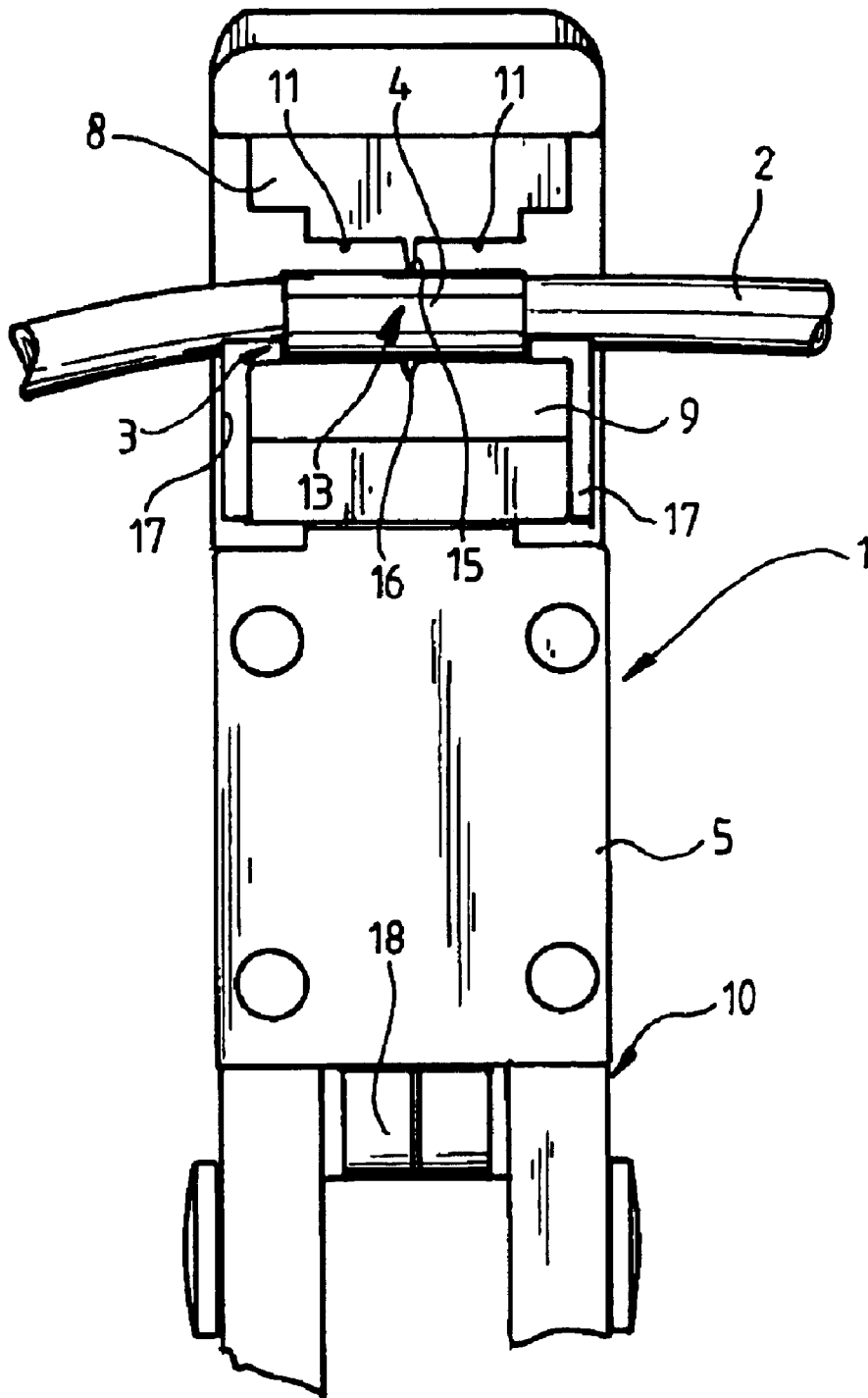

Fig. 2

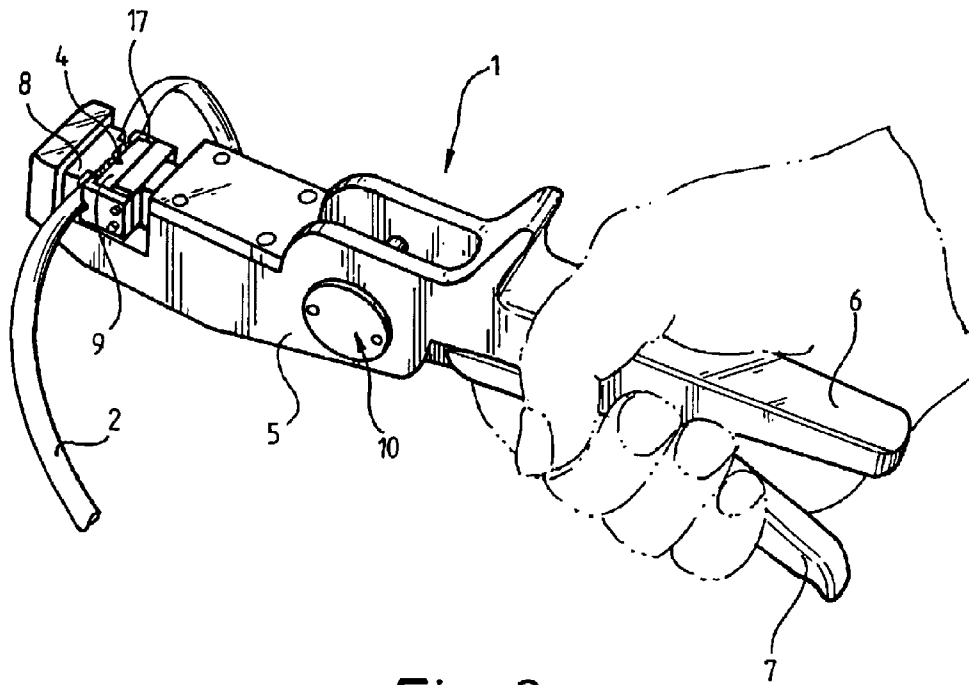

Fig. 3

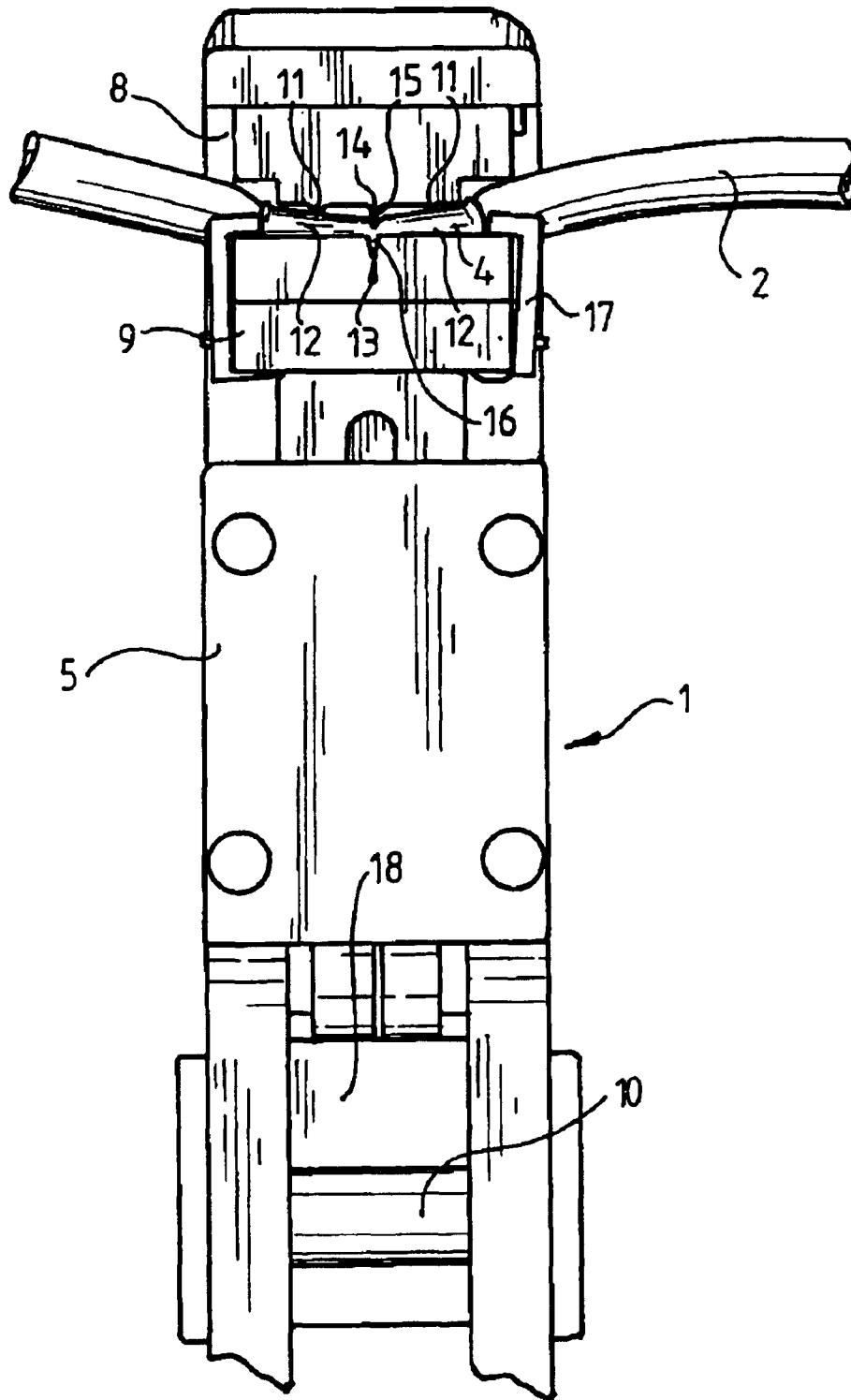

Fig. 4

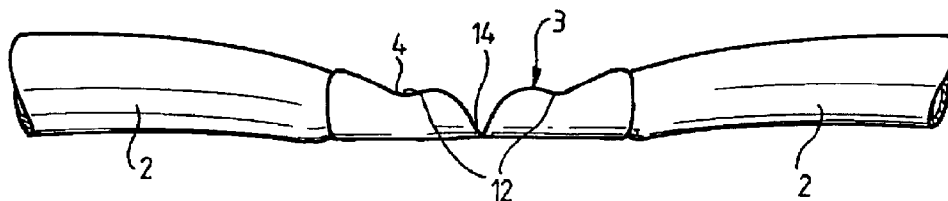

Fig. 5A

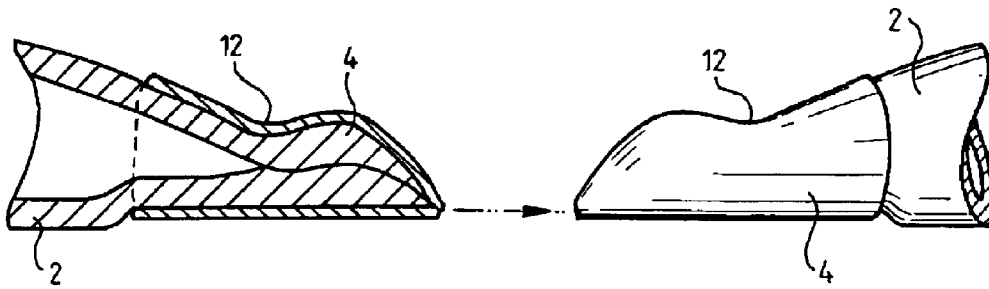

Fig. 5B

SEALING APPLIANCE

Matter enclosed in heavy brackets [] appears in the original patent but forms no part of this reissue specification; matter printed in italics indicates the additions made by reissue; a claim printed with strikethrough indicates that the claim was canceled, disclaimed, or held invalid by a prior post-patent action or proceeding.

This application is a continuation reissue application of U.S. patent application Ser. No. 12/422,820, which is a divisional reissue application of U.S. patent application Ser. No. 11/305,813, filed Dec. 19, 2005, now U.S. Pat. No. Re. 41,169, which is a reissue application of U.S. Pat. No. 6,779,575, issued on Aug. 24, 2004, which was a national stage application of PCT/SE99/00878, filed May 25, 1999, which claims priority to SE-9801885, filed May 28, 1998, the disclosures of which are herewith incorporated by reference in their entirety.

More than one reissue application has been filed for the reissue of U.S. Pat. No. 6,779,575. The reissue applications are application Ser. No. 11/305,813, filed Dec. 19, 2005 (the original reissue application); application Ser. No. 12/422,820, filed Apr. 13, 2009, which is a divisional reissue of Ser. No. 11/305,813; application Ser. No. 12/422,835 (now U.S. Pat. No. 7,959,754), filed Apr. 13, 2009, which is a divisional reissue of application Ser. No. 11/305,813; application Ser. No. 13/092,522, filed Apr. 22, 2011 (abandoned); application Ser. No. 13/536,199, filed Jun. 28, 2012, which is a continuation reissue of application Ser. No. 12/422,820; application Ser. No. 13/613,669, filed Sep. 13, 2012, which is a continuation reissue of application Ser. No. 12/422,820; and application Ser. No. 13/613,658 (the present application), filed Sep. 13, 2012, which is a continuation reissue of application Ser. No. 12/422,820.

TECHNICAL FIELD

The present invention relates to an appliance for mechanical sealing of hollow hoses of elastic material with a sealing means which is made of plastically deformable material and which is applied to the hose, said appliance having two jaws, which are movable towards and away from each other and which, when moving towards each other, crimp the sealing means against the hose to seal the same.

BACKGROUND OF THE INVENTION

In a prior-art sealing appliance of the type mentioned by way of introduction, the sealing means in the form of a folded clip is applied to a likewise folded end of the hose. The clip is then crimped against the hose to seal the same, after which the hose is cut downstream of the clip by means of a pair of scissors or some other cutting tool.

As the relevant hoses have a relatively small diameter, say 5-10 mm, the clips are also relatively small and often difficult to apply in the right position on the folded end of the hose. Nor is it infrequent that the clip falls off the end of the hose, before the sealing appliance has managed to grip it for crimping against the hose with the ensuing risk of sealing not taking place.

The sealing appliance according to the invention is primarily to be used in the type of device which is intended for introduction and/or withdrawal of a medium in a container and which is disclosed and described in WO 97/16715. More

specifically, it is intended for contamination-free sealing and cutting of the hoses which extend between the conveying means and the collecting vessels which are connected to the process container, so that the collecting vessels after being filled with a medium from the process container can be moved without any risk of contamination to a laboratory or the like for sampling or analysis of the medium.

In the above use of the sealing appliance, which requires good hygienic conditions and contamination-free environment/surroundings, clips of the mentioned type are unacceptable. One reason for this is that they are difficult to handle and often do not provide the desired sealing. Another reason is that there is in most cases at least a small portion of the hose left downstream of the clip containing a small quantity of the medium which leaks out to the surrounding area with an obvious risk of contamination.

OBJECT OF THE INVENTION

The main object of the present invention is to provide a sealing appliance of the type mentioned by way of introduction, satisfying all the requirements for contamination-free transport of the relevant collecting vessels, which are filled with a medium, to the laboratory or the like.

SUMMARY OF THE INVENTION

This as well as related objects are achieved in a simple and efficient manner in that the sealing means has the form of a sleeve which is slipped on to the hose, that at least one of the jaws has at least one bar which projects towards the other jaw and which, when the jaws are moving towards each other, makes an indentation in the sleeve and the hose to reinforce the sealing thereof as well as the fixing of the sleeve on the hose, and that at least one of the jaws has a cutting means, which projects towards the other jaw and which, when the jaws are moving towards each other, makes a cutting indication in the sleeve and the hose to allow a sealing cutting of the hose.

In a particularly preferred embodiment there are at least two straight bars which are arranged substantially in parallel at a distance from each other and extend substantially transversely of the longitudinal direction of the sleeve to make a corresponding number of substantially transverse indentations in the sleeve and the hose, the cutting means preferably extending substantially transversely of the longitudinal direction of the sleeve and making a substantially transverse cutting indication in the sleeve and the hose.

BRIEF DESCRIPTION OF THE DRAWINGS

The invention will be described below in more detail with reference to the accompanying drawings, in which

FIG. 1 is a perspective view, seen obliquely from above, of an appliance according to a currently particularly preferred embodiment of the invention in an initial position for the sealing of a hose,

FIG. 2 is a front view of a part of the appliance according to FIG. 1 in the initial position,

FIG. 3 is a perspective view of the appliance corresponding to FIG. 1 in end position of the sealing,

FIG. 4 is a view corresponding to FIG. 2, the appliance being in the end position, and

FIGS. 5A and 5B are side views which show the sealed hose, partially cut open, in a position after sealing and in a position after completed cutting of the hose.

DESCRIPTION OF A PREFERRED EMBODIMENT

As mentioned above, the appliance generally designated **1** is primarily conceived for use in the type of device which is intended for introduction and/or withdrawal of a medium in a container and which is disclosed and described in WO 97/16715. More specifically, it is intended for sealing and cutting the hoses in a mechanical and contamination-free manner, which extend between the conveying means and the collecting vessels which are connected to the process container, so that the collecting vessels after being filled with a medium from the process container can be transported without any risk of contamination to a laboratory or the like for sampling or analysis of the medium.

Still, the appliance **1** can, of course, also be used in a number of other applications where good hygienic conditions and/or contamination-free surroundings and/or working environment are required to a varying extent.

Thus the appliance **1** is generally intended for mechanical sealing of hollow hoses **2** of elastic material, e.g. rubber or plastic, of a quality which is suitable for the purpose. The sealing is carried out with the aid of a sealing means **3**, which is made of a plastically deformable material, e.g. plastic or metal, having suitable plastic properties and which is applied to the hose **2**. In the preferred embodiment shown, the sealing means **3** consists of a metal sleeve **4** which has been slipped on to the hose **2** in advance. The sleeve has a length of preferably two or more multiples of the diameter of the hose **2**, which in turn is typically in the range of 5-10 mm.

As shown in FIGS. 1 and 3, the appliance **1** itself can have the form of a pair of tongs **5** which is hand-operated and which has one fixed and one movable leg **6** and **7** and two jaws **8** and **9** which are movable towards and away from each other. When moving the jaws **8**, **9** towards each other by manually pressing the legs **6**, **7** together and using a driving means **10**, which will be described below, the sleeve **4** is crimped against the hose **2**, thereby sealing the same.

More specifically, as best seen in FIG. 2, at least one of the jaws **8** or **9**, in this case the jaw **8**, has at least one bar **11** which projects towards the other jaw **9** or **8**, in this case the jaw **9**. In the above-described movement of the jaws **8**, **9** towards each other, this bar **11** makes a marked indentation **12**, see FIGS. 4, 5A and 5B, in the sleeve **4** and in the hose **2**. In the preferred embodiment, there are two such bars **11**, which are placed substantially in parallel at a distance from each other and extend substantially transversely of the longitudinal direction of the sleeve **4**. The bars **11** are preferably straight and make two substantially transverse indentations **12** in the sleeve **4** and in the hose **2** to reinforce the sealing thereof as well as the fixing of the sleeve **4** on the hose **2**. If desired and if suitable, there may, of course, be more than two such bars **11** or bars which are differently placed/formed on said jaw **8**.

Moreover, at least one of the jaws **8** or **9**, also in this case the jaw **8**, has a cutting means **13** projecting towards the other jaw **9** or **8** (see FIGS. 2 and 4). When the jaws **8**, **9** are moving towards each other in the described manner, this cutting means **13** makes a cutting indication **14** in the sleeve **4** and in the hose **2** to allow the sleeve and the hose to be cut in a sealing manner.

In the shown embodiment, the cutting means **13** is preferably formed as a substantially straight cutting edge **15**. The cutting edge extends substantially transversely of the longitudinal direction of the sleeve **4** and thus makes a substantially transverse cutting indication **14** in the sleeve **4** and in the hose **2**. As seen in FIGS. 2 and 4, the cutting edge **15** projects to greater extent than the bars **11** and suitably co-operates with

an opposite, straight recess **16** in the opposite jaw, in this case the jaw **9**. The depth, width and form of the recess **16** can vary, and the recess is suitably adapted to the form of the cutting edge **15** and to the qualities of the material of the hose **2** and the sleeve **4**. In certain applications, the recess **16** can, if required or desired, be omitted.

Preferably, the cutting edge **15** is situated substantially halfway between the bars **11**, if they are two in number, such as shown in FIGS. 2 and 4. If there are further bars **11**, the cutting edge **15** is suitably placed halfway between two adjacent bars, preferably the ones situated closest to the middle. In a certain application, it is, of course, also possible to place the cutting edge **15** outside or on one side of the bar or the bars **11**.

The cutting indication **14** mentioned above is preferably such that the sleeve **4** and the hose **2** are not cut or broken directly when sealing by means of the appliance **1**, such as shown in FIG. 5A, but at an optional point of time after that. Then the sleeve **4** and the hose **2** are separated along the cutting indication **14** by manual or mechanical bending back and forth, until the sleeve is divided by fatigue fracture, as shown in FIG. 5B.

Naturally, nothing prevents the sleeve **4** and the hose **2** from being separated along the cutting indication **14** directly in connection with the actual sealing.

To fix the sleeve **4** and the hose **2** in the intended position between the jaws **8** and **9** in the appliance **1** when sealing, at least one of the jaws **8** or **9**, in this case the jaw **9**, has a fixture **17**. The fixture fixes and supports the hose **2** and the sleeve **4** laterally, horizontally and vertically and can be formed in an optional manner which is not described in further detail.

For practical and other reasons, in the disclosed and described embodiment the bars **11** and the cutting edge **15** are arranged on one of the jaws **8** or **9**, in this case the jaw **8**, and the fixture **17** on the other, opposite jaw **9** or **8**, in this case the jaw **9**. The bars **11**, the cutting edge **15** and the fixture **17** can be mounted on the associated jaw **8**, **9** with the aid of suitable attachment means, which are not shown. Alternatively, one/some of or all these components can be made in one piece with the associated jaw. In the shown case, the bars **11** and the cutting edge **15** are made in one piece with the associated jaw, whereas the fixture **17** is mounted on the associated jaw, see FIGS. 2 and 4.

In the preferred embodiment, the jaw **8** provided with the bars **11** and the cutting edge **15** suitably has the form of a die which is fixedly mounted in the appliance **1** with the aid of attachment means (not shown), see FIGS. 2 and 4. In a corresponding manner, the jaw **9** provided with the fixture **17** has the form of a punch. This punch is mounted in a slidable manner (not shown) in the appliance **1** and is actuatable by the previously mentioned driving means **10**. The driving means **10** suitably consists of a gear generally designated **18**, which can be an eccentric mechanism or the like and which is suitably connected to and actuatable by means of the movable leg **7** of the pair of tongs **5**.

The invention is not, of course, limited to the embodiment which is described above and shown in the drawings, and can be modified in many different ways within the scope of protection according to the appended claims.

The appliance **1** does not, for example, need to be a manually operable pair of tongs, but it can alternatively be a separate tool or a tool which is included in a machine and driven electrically, pneumatically, hydraulically etc according to need and desire. The jaws **8**, **9** with the associated components (bars **11**, cutting edge **15** and fixture **17**) can be attached to the appliance **1** in a replaceable manner and match the size of the hose **2** and the sleeve **4** and/or be mutually exchangeable etc.

What is claimed is:

[1. An appliance for mechanical sealing of hollow hoses (2) of elastic material with a sealing means (3) which is made of plastically deformable material and which is applied to the hose, said appliance (1) having two jaws (8, 9), at least one of the jaws is movable towards and away from the other jaw and the jaws crimp the sealing means (3) against the hose (2) to seal the same, characterised in that the sealing means (3) has the form of a sleeve (4) which is slipped on to the hose (2), that at least one of the jaws (8 or 9) has at least one straight bar (11) having a projecting end which projects towards the other jaw (9 or 8) and which, when at least one the jaws is moving towards the other jaw, makes an indentation (12) in the sleeve (4) and the hose (2) to reinforce the sealing thereof as well as the fixing of the sleeve on the hose, that at least one of the jaws (8 or 9) has a cutting means (13), which projects towards the other jaw (9 or 8) and which when at least one of the jaws (8, 9) is moving towards the other jaw, makes a cutting indication (14) in the sleeve (4) and the hose (2) to allow a sealing cutting of the hose (2), and that the cutting means (13) has the form of a substantially straight cutting edge (15) which projects to a greater extent than the projecting end of said at least one bar (11).]

[2. An appliance according to claim 1, characterized in that there are at least two straight bars (11) having projecting ends which are arranged substantially in parallel at a distance from each other and extend substantially transversely of the longitudinal direction of the sleeve (4) to make a corresponding number of substantially transverse indentations (12) in the sleeve (4) and the hose (2), and that the cutting means (13) extends substantially transversely of the longitudinal direction of the sleeve (4) and makes a substantially transverse cutting indication (14) in the sleeve (4) and the hose (2).]

[3. An appliance according to claim 2, characterized in that the cutting means (13) has the form of a substantially straight cutting edge (15), which projects to a greater extent than the projecting ends of the at least two straight bars (11).]

[4. An appliance according to claim 3, characterized in that the cutting edge (15) cooperates with an opposite recess (16) in the other jaw (9 or 8) and is situated substantially halfway between two adjacent bars (11);

at least one of the jaws (8 or 9) has a fixture (17) to position the sleeve (4) and the hose (2) between the jaws (8, 9); the bars (11) and the cutting edge (15) are situated on one jaw (8) and that the fixture (17) is situated on the other jaw (9), the bars, the cutting edge and the fixture being mounted on or being made in one piece with the associated jaw,

the jaw (8) provided with the bars (11) and the cutting edge (15) has the form of a die, which is fixedly mounted in the appliance (1) and the jaw (9) provided with the fixture (17) has the form of a punch, which is movably arranged in the appliance (1) and actuable by a driving means (10); and

the appliance has the form of a pair of tongs (5) which is hand operated and has one fixed and one movable leg (6, 7), the movable leg (7) actuating the jaw (9) forming the punch by means of a gear drive.]

[5. An appliance according to claim 3, characterized in that the cutting edge (15) cooperates with an opposite recess (16) in the other jaw (8 or 9);

the cutting edge (15) is situated on one side of the bars (11); at least one of the jaws (8 or 9) has a fixture (17) to position the sleeve (4) and the hose (2) between the jaws (8, 9); the bars (11) and the cutting edge (15) are situated on one jaw (8) and the fixture (17) is situated on the other jaw

(9), the bars, the cutting edge and the fixture being mounted on or being made in one piece with the associated jaw;

the jaw (8) provided with the bars (11) and the cutting edge (15) has the form of a die, which is fixedly mounted in the appliance (1) and the jaw (9) provided with the fixture (17) has the form of a punch, which is movably arranged in the appliance (1) and actuable by driving means (10); and

the appliance has the form of a pair of tongs (5) which is hand operated and has one fixed and one movable leg (6, 7), the movable leg (7) actuating the jaw (9) forming the punch by means of a gear device.]

[6. An appliance according to claim 2, characterized in that at least one of the jaws (8 or 9) has a fixture (17) to position the sleeve (4) and the hose (2) between the jaws (8, 9).]

[7. An appliance according to claim 2, characterized in that the at least two bars (11) and the cutting edge (15) are situated on one jaw (8), and that the fixture (17) is situated on the other jaw (9), at the least one bar, the cutting edge and the fixture being mounted on or being made in one piece with the associated jaw.]

[8. An appliance according to claim 1, characterized in that the cutting edge (15) co-operates with an opposite recess (16) in the other jaw (9 or 8).]

[9. An appliance according to claim 8, characterized in that the cutting edge (15) is situated substantially half-way between two adjacent bars (11).]

[10. An appliance according to claim 8, characterized in that the cutting edge (15) is situated on one side of the at least one bar (11).]

[11. An appliance according to claim 8, characterized in that at least one of the jaws (8 or 9) has a fixture (17) to position the sleeve (4) and the hose (2) between the jaws (8, 9).]

[12. An appliance according to claim 1, characterized in that the cutting edge (15) is situated substantially half-way between two adjacent bars (11).]

[13. An appliance according to claim 1, characterized in that the cutting edge (15) is situated on one side of the at least one bar (11).]

[14. An appliance according to claim 1, characterized in that at least one of the jaws (8 or 9) has a fixture (17) to position the sleeve (4) and the hose (2) between the jaws (8, 9).]

[15. An appliance according to claim 14, characterized in that the at least one bar (11) and the cutting edge (15) are situated on one jaw (8), and that the fixture (17) is situated on the other jaw (9), the at least one bar, the cutting edge and the fixture being mounted on or being made in one piece with the associated jaw.]

[16. An appliance according to claim 15, characterized in that the jaw (8) provided with the at least one bar (11) and the cutting edge (15) has the form of a die, which is fixedly mounted in the appliance (1), and that the jaw (9) provided with the fixture (17) has the form of a punch, which is movably arranged in the appliance (1) and actuable by a driving means (10).]

[17. An appliance according to claim 16, characterized in that it has the form of a pair of tongs (5) which is hand-operated and has one fixed and one movable leg (6, 7), the movable leg (7) actuating the jaw (9) forming the punch by means of a gear device, preferably an eccentric mechanism or the like, forming the driving means (10).]

[18. An appliance for mechanical sealing of hollow hoses (2) of elastic material with a sealing means (3) which is made of plastically deformable material and which is applied to the

hose, said appliance (1) having two jaws (8, 9), both of the jaws are movable towards and away from each other and which, when moving towards each other, crimp the sealing means (3) against the hose (2) to seal the same, characterised in that the sealing means (3) has the form of a sleeve (4) which is slipped on to the hose (2), that at least one of the jaws (8 or 9) has at least one straight bar (11) having a projecting end which projects towards the other jaw (9 or 8) and which, when the jaws (8, 9) are moving towards each other, makes an indentation (12) in the sleeve (4) and the hose (2) to reinforce the sealing thereof as well as the fixing of the sleeve on the hose, that at least one of the jaws (8 or 9) and which, when the jaws (8, 9) are moving towards each other, makes a cutting indication (14) in the sleeve (4) and the hose (2) to allow a sealing cutting of the hose (2), and that the cutting means (13) has the form of a substantially straight cutting edge (15), which projects to a greater extent than the projecting end of said at least one bar (11).]

19. A hand-held sealing appliance, comprising:

jaws mounted to receive a hose and operable for relative movement;

an indentation projection, supported by at least one of the jaws, that provides an indentation in the hose; and at least one cutting indication projection, supported by at least one of the jaws, that makes a cutting indication in the hose at a location longitudinally displaced from the indentation, the cutting indication extending farther into the hose than the indentation.

20. The appliance of claim 19, wherein the indentation projection and the cutting indication projection are fixed relative to each other on the same jaw.

21. The appliance of claim 19, further comprising a second indentation projection on one of the jaws to provide a second indentation in the hose, the at least one cutting indication projection being positioned longitudinally between the indentation projections.

22. The appliance of claim 19, wherein the hose is separated along the cutting indication.

23. The appliance of claim 19, further comprising a sealing element of plastically deformable material positioned about the hose at the indentation projection and at the at least one cutting indication projection.

24. The appliance of claim 19, further comprising a plastically deformable sleeve about the hose at the indentation projection and at the at least one cutting indication projection.

25. The appliance of claim 24, wherein the plastically deformable sleeve is metal.

26. The appliance of claim 19, wherein the jaws are manually operable.

27. The appliance of claim 19, further comprising a fixture to position the hose between the jaws.

28. The appliance of claim 19, wherein one of the jaws is fixed in the appliance.

29. The appliance of claim 19, wherein the indentation projection and one of the at least one cutting indication projection are supported by the jaw.

30. The appliance of claim 19, wherein the cutting indication projection cooperates with an opposite recess in the jaw opposite the cutting indication projection.

31. A method of sealing and allowing separation of a hose, comprising:

providing a hand-held appliance having jaws, and indentation projection extending from one of the jaws and a cutting indication projection extending from one of the jaws;

positioning the hose between the jaws of the hand-held appliance; and

causing relative movement between the jaws, the projection forming an indentation in the hose and the cutting indication projection forming a cutting indication in the hose at a location longitudinally displaced from the indentation, the cutting indication extending farther into the hose than the indentation.

32. The method of claim 31, wherein the indentation projection and the cutting indication projection are fixed relative to each other on the same jaw.

33. The method of claim 31, wherein a second indentation projection on one of the jaws forms a second indentation in the hose, the cutting indication being positioned longitudinally between the indentations.

34. The method of claim 31, wherein the hose is separated along the cutting indication.

35. The method of claim 31, further comprising positioning a sealing element of plastically deformable material about the hose at the indentation projection and at the cutting indication projection.

36. The method of claim 31, further comprising positioning a plastically deformable sleeve about the hose at the projection and at the cutting indication projection.

37. The method of claim 31, wherein the jaws are operated manually.

38. The method of claim 31, wherein one of the jaws is fixed in the appliance.

39. The method of claim 31, wherein the indentation and the cutting indication are made on the same side of the hose.

40. A hand-held sealing appliance, comprising: jaws mounted to receive a hose and operable for relative movement;

indentation means for forming an indentation, supported by at least one of the jaws, that provides an indentation in the hose; and

cutting means for forming a cutting indication, supported by at least one of the jaws, that makes a cutting indication in the hose at a location longitudinally displaced from the indentation, the cutting means extending farther into the hose than the indentation.

41. A hand-held sealing appliance, comprising:

jaws mounted to receive a segment of a hollow hose of elastic material and operable for relative movement, the hose segment being surrounded by a sealing device;

a fixture configured to position the sealing device and the hose between the jaws; and

at least one cutting indication projection, supported by at least one of the jaws, that makes a cutting indication in the hose.

42. The appliance of claim 41, wherein the fixture fixes and supports the hose and the sealing device at least one of laterally, horizontally, and vertically.

43. The appliance of claim 42, wherein the fixture fixes and supports the hose and the sealing device at least two of laterally, horizontally, and vertically.

44. The appliance of claim 42, wherein the fixture fixes and supports the hose and the sealing device laterally, horizontally, and vertically.

45. The appliance of claim 41, wherein the fixture at least partially encloses the sealing device.

46. The appliance of claim 41, which achieves a contamination-free sealing and cutting of the hose.