

(19)



(11)

EP 3 290 790 B1

(12)

EUROPEAN PATENT SPECIFICATION

(45) Date of publication and mention of the grant of the patent:
10.04.2019 Bulletin 2019/15

(51) Int Cl.:
F21V 29/508 ^(2015.01) **F21V 29/77** ^(2015.01)
F21V 23/00 ^(2015.01) **F21Y 115/10** ^(2016.01)
F21Y 105/18 ^(2016.01)

(21) Application number: **16186226.3**

(22) Date of filing: **30.08.2016**

(54) **HEATSINK**

KÜHLKÖRPER

DISSIPATEUR THERMIQUE

(84) Designated Contracting States:
AL AT BE BG CH CY CZ DE DK EE ES FI FR GB GR HR HU IE IS IT LI LT LU LV MC MK MT NL NO PL PT RO RS SE SI SK SM TR

(43) Date of publication of application:
07.03.2018 Bulletin 2018/10

(73) Proprietors:
 • **ZG Lighting Benelux**
2870 Puurs (BE)
 • **Zumtobel Lighting GmbH**
6850 Dornbirn (AT)

(72) Inventors:
 • **Usher, Christian**
1183 HE Amsteleveen (NL)

• **Favarolo, Angelo**
88239 Wangen im Allgäu (DE)

(74) Representative: **Thun, Clemens Mitscherlich PartmbB Patent- und Rechtsanwälte Sonnenstraße 33 80331 München (DE)**

(56) References cited:
WO-A1-2013/057433 WO-A1-2015/186016
US-A1- 2010 226 139 US-A1- 2011 032 696
US-A1- 2011 316 014 US-A1- 2013 294 083
US-A1- 2014 347 848

EP 3 290 790 B1

Note: Within nine months of the publication of the mention of the grant of the European patent in the European Patent Bulletin, any person may give notice to the European Patent Office of opposition to that patent, in accordance with the Implementing Regulations. Notice of opposition shall not be deemed to have been filed until the opposition fee has been paid. (Art. 99(1) European Patent Convention).

Description

1. Field of the invention

[0001] The present invention relates to luminaires having a high lumen output resulting in an excessive heat generation. In particular, the present invention relates to a heatsink which is used in such a luminaire.

2. Technical background

[0002] In the prior art, luminaires having a high lumen output are well known. Those luminaires usually comprise a driver and a light source having a light emitting direction of the light source for constituting a main beam direction of the luminaire. The driver is usually provided somewhere at the rear side a housing of a central supporting element of the luminaire with respect to the light emitting direction of the light source.

[0003] During operation of the luminaire, heat is generated by the driver but in particular by the light source. Today, mostly light sources on the basis of LEDs are used which require a reliable cooling during operation to avoid local high temperatures which could result in damages not only of the LEDs but also of other components of the luminaire.

[0004] WO 2015/186016 A1 is directed to heat sinks for light emitting devices. In particular, the heat sinks can provide effective heat dissipation in a variety of different orientations and positions. In one exemplary heat sink, different groups of essentially parallel fins can be separated and disposed at particular angles to form fluid channels that enable fluid flow in different directions and orientations.

[0005] WO 2013/057433 A1 relates to an illuminating device comprising light-emitting diodes, said device being equipped with a heat dissipator comprising inter alia a radiator. The radiator, consisting of a single-part element, comprises a plate and fins extending around said plate, said fins being oriented substantially perpendicular to said plate in such a way as to allow the light-emitting diodes to be cooled by natural convection.

[0006] In US2010226139 an LED-based luminaire employs an LED module mounted to a housing. The LED module is advantageously configured to transmit heat generated by the LEDs across and/or through the module and to the housing for dispersal to the environment. LED modules can be configured with conductive or non-conductive cores and may be configured to evacuate heat from one or both faces of the LED module. Multiple heat paths can be defined from components on an LED module to the housing and to the environment.

[0007] In the prior art therefore, heatsinks are known being in thermal contact with heat generating components of the luminaire and having an enlarged surface configuration for transferring the heat to the surrounding air. These heatsinks have been optimized in the past and indeed help to keep the temperatures in luminaires at an

acceptable level. On the other hand, in case such heat-sinks are in thermal contact with the light source and other electric components such as drivers, there is a risk that the heatsink even supports a transfer of heat from the light source to the driver or in the other direction.

[0008] Therefore, it is an object of the present invention to provide a luminaire that is compact and that allows that the driver is not being affected by the heat of the luminaire.

[0009] These and other objects, which become apparent upon reading the following description, are solved by the subject-matter of the independent claim. The dependent claims refer to preferred embodiments of the invention.

3. Summary of the invention

[0010] According to the present invention, a heatsink for a luminaire is provided wherein the heatsink comprises a first portion being adapted for arranging a light source driver, an emergency lighting unit or a housing for accommodating a light source driver or an emergency lighting unit; and a second portion being integrally formed with the first portion and adapted for arranging a light source. In order to prevent a transfer of heat from the light source to the driver or the emergency lighting unit, at least some cooling fins extending from the first portion of the heatsink to the second portion of the heatsink are interrupted by a gap. To improve the handling of the heat source, the heatsink further comprises support elements extending from the first portion of the heatsink to the second portion. The invention is characterized in that the support elements comprise a cut which splits each support element in two portions and wherein the cut diagonally extends through the support element, preventing a transfer of heat from the light source to the electrical components or in the other direction.

[0011] Accordingly, an integrally formed heatsink is provided which is used to cool simultaneously the light source and other electrical components wherein nevertheless a (cross) transfer of heat is prevented by using cooling fins having a gap. Each gap divides the corresponding cooling fin then in a first cooling fin portion and a second cooling fin portion wherein both portions are aligned with each other. The gap preferably separates both cooling fin portions by distance of around 3 to 7 mm, preferably by around 5mm.

[0012] Depending on the amount of heat generated by the different components of the luminaire, the length ratio between the cooling fin portions can be adapted. However, preferably the length ration between the first cooling fin portion and the second cooling fin portion is around 1:4 considering the fact that usually the light source generates more heat than the light source driver.

[0013] In a preferred embodiment of the present invention, the heatsink has a circular configuration with the first portion forming a center portion of the heatsink and the second portion forming an outer portion. The cooling

fins then preferably radially extend outwardly from the first portion of the heatsink to the second portion wherein in particular cooling fins are evenly distributed over the circumference of the heatsink. The heatsink further can comprise a central hole being adapted for being combined with a housing for accommodating a light source driver or an emergency lighting unit. To arrange the light source, the heatsink further comprises preferably a receiving groove, e.g. a circumferentially extending receiving groove.

[0014] As an alternative to the above-mentioned circular configuration, the heatsink can also have a longitudinal configuration with both portions extending parallel to each other. In particular, the heatsink can comprise a further second portion being adapted for arranging another light source wherein the first portion extends between both second portions.

[0015] According to the present invention, also a luminaire having a main beam direction is provided comprising a heatsink as defined above, a light source mounted to the heatsink and a driver configured to drive the light source. Preferably, the light source is an LED light source.

4. Description of a preferred embodiment

[0016] In the following, the invention is described exemplarily with reference to the enclosed figures in which

Figure 1 is a schematic cross-sectional view of a preferred embodiment of an inventive luminaire;

Figure 2 is a schematic cross-sectional view of a heatsink in a traditional configuration;

Figure 3 is a schematic cross-sectional view similar to figure 2 but showing an inventive heatsink;

Figure 4 is a schematic view showing the distribution of the temperatures during use of the luminaire;

Figure 5 is a top view of the inventive heatsink; and

Figure 6 is another cross-sectional view of the inventive luminaire showing in particular the structure of the supporting elements.

[0017] Figure 1 is a cross-sectional view of a luminaire 10 comprising a heatsink 1 according to a preferred embodiment of the present invention. The luminaire 10 of the preferred embodiment is a luminaire for being operated with a high lumen output and/or in environments having a high ambient temperature. The luminaire 10 has a main beam direction B.

[0018] The luminaire 10 comprises as a main compo-

nent a heatsink 1. In the preferred embodiment of Figure 1, the heatsink 1 has a substantially round and symmetrical shape. The heatsink 1 is, however, not restricted to a particular shape and could for example also be realized in a longitudinal shape. The heatsink 1 has such a shape that its surface is increased for facilitating heat flow. Increasing the surface of the heatsink 1 is achieved by (integrally) providing cooling fins 1g with the heatsink 1, which are preferably evenly distributed over the circumference of the heatsink 1. The cooling fins 1g may extend radially and may be arranged annularly with respect to the main beam direction B. Preferably, the cooling fins 1g constitute a lattice-like heatsink 1, thus providing an increased surface of the heatsink 1 for facilitating cooling of different components of the luminaire 10.

[0019] The luminaire 10 further comprises a light source 2 mounted to the heatsink 1. As can be seen from the cross sectional view of Figure 1, the light source 2 is preferably mounted to the heatsink 1 by means of a receiving groove 1d that slightly extends in the heatsink 1 preferably around the main beam direction B and receives the light source 2. Preferably, the receiving groove 1d extends in the plurality of cooling fins 1g and forms an annular space for arranging the light source 2. It should be noted that also other means for mounting the light source 2 are possible, such as by means of fixing elements or the like.

[0020] The light source 2 may have a substantially two-dimensional extension and has in the present embodiment an annular shape. The light source 2 may comprise one or more LED modules. The LED-module(s) may be in plane contact with the heatsink 1. The LED module(s) may comprise at least one LED and/or printed circuit board (PCB). Preferably, the at least one LED is bonded to the printed circuit board.

[0021] Furthermore, the luminaire 10 comprises a driver 3 configured to drive the light source 2. As can be seen from Figure 1, the luminaire 10 may comprise a housing 5 for enclosing and preferably holding the driver 3. Holding the driver 3 may be carried out by holding elements (not shown) provided in the housing 5. Preferably, the housing 5 is designed for further enclosing and optionally holding also further components, e.g. a battery, and/or the further electronic and/or electric components. The housing 5 may be mounted to the heatsink 1 by means of a corresponding connection between a central opening 1a of the heatsink 1 and the housing 5, such as an engagement of corresponding connection means, a transition fit, a snap fit or the like. In addition or alternatively, the housing 5 may be mounted to the heatsink 1 by means of fixing elements, such as bolts, nuts or the like. Preferably, the housing 5 comprises an opening 5a facing towards the heatsink 1. The opening 5a may face the opening 1a of the heatsink 1. Furthermore, the driver 3 may extend through the opening 5a into the opening 1a.

[0022] In the preferred embodiment according to Figure 1, the housing 5 has a substantially cylindrical shape that tapers in a direction away from the heatsink 1, i.e. a

substantially cone-shaped form. However, the housing may also have a different shape, such as a rectangular shape or the like. The end of the housing 5 facing towards the heatsink 1 may be held by the opening 1a of the heatsink 1. Said end may comprise a rim 5b that is preferably received by a connection groove 1b extending in a step of the opening 1a. The connection groove 1b may further comprise engaging elements for engagement of the housing 5.

[0023] The housing 5 for accommodating the driver 3 may comprise a plurality of cooling fins 5c. The cooling fins 5c may be evenly distributed over the circumference of the housing 5. These cooling fins 5c may extend from the opening 5b of the housing 5 in the extending direction of the housing 5, preferably away from the heatsink 1, substantially in the direction of the main beam direction B. As viewed perpendicular to the extending direction of the housing 5, the longitudinal axis L, respectively, the cooling fins 5c may be wedge-shaped. However, the cooling-fins 5c may also have any different shape, such as a rectangular shape or the like, that increases the total surface of the housing 5 for facilitating cooling of the components enclosed in the housing 5.

[0024] The plurality of cooling fins 5c may engage with the opening 1a of the heatsink 1 for mounting the housing 5 on the heatsink 1. This arrangement also provides a heat flow from the housing 5 by way of the cooling fins 5c to the heatsink 1 where the heat is finally transferred to the surrounding air.

[0025] Preferably, the opening 1a of the heatsink 1 comprises recesses 1e, in particular slots, corresponding to the shape and preferably to the number of the plurality of cooling fins 5c for engagement of the cooling fins 5c with the opening 1a. Furthermore, as can be seen in Figure 1, the cooling fins 5b may abut the step 1c of the opening 1a on the face side of the cooling fins 5b. The cooling fins 1g of the heatsink 1 and the cooling fins 5c of the housing 5 may thermally cooperate with each other, e.g. by extending longitudinally from one another, to form a combined cooling body. As such, the housing 5 may also be integrally formed with the heatsink 1.

[0026] The material of the housing 5 and the cooling fins 5c, respectively, has a high thermal conductivity for facilitating cooling. Preferably, the material of the housing 5 is metal. The material of the heatsink 1 may also have a high thermal conductivity for facilitating cooling, such as metal or the like.

[0027] The luminaire 10 may further comprise an optical system 4 provided on the side of the light source 2 being opposite to the heatsink 1 for influencing the light emitted by the light source 2. For instance, the optical system 4 may influence the emitted light to constitute the main beam direction B. For facilitating heat flow from the optical system 2 to the heatsink 1, the optical system 4 may be connected to, preferably mounted on, the heatsink 1. The optical system 4 may cover the receiving groove id, and thus preferably also covers the light source 2. As an alternative, the optical system 4 may also be

provided/placed within the receiving groove id, i.e. the optical system 4 may be received by the receiving groove id and may cover the light source 2.

[0028] The heatsink 1 may further comprise attaching elements if for attaching the luminaire, e.g. to a housing, a ceiling, a wall etc. The attaching elements if are preferably provided on a side of the heatsink 1 being opposite to the side of the heatsink 1, where the light source 2 is mounted.

[0029] During operation of the luminaire 10, heat is generated by the light source 2 and the driver 3. Both components are, as explained above, thermally coupled to the heatsink 1 and thus heat is transferred to the heatsink 1 from the light source 2 but also from the driver 3.

[0030] A heatsink 1 in traditional configuration is shown in Figure 2. For practical reasons, it is of course preferred that the heatsink 1 is integrally formed and thus both parts of the heatsink 1 to which the light source 2 and the driver housing 5 are attached are connected with each other. In the exemplified shown in Figure 2, this connection is realized by the radially extending cooling fins 15 which extend from the central opening 1a of the heatsink 1 to its circumference. These cooling fins 15, on the other, not only mechanically couple both regions of the heatsink 1 with each other but also result in a thermal coupling between both regions. Heat generated by the light source 2 can thus be transferred in the center region surrounding the driver 3 and vice versa.

[0031] It now has been found that the transfer of heat in particular from the LED light sources 2 to the driver 3 via cooling fins 15 can have a negative influence on the performance of the driver 3. In particular in situations where the luminaire 10 is operated at relatively high ambient temperatures, this transfer of heat from the light sources 2 to the driver 3 can reduce the output of the driver 3 and/or its lifetime. Also additional elements for emergency lighting like batteries which are arranged in housing 5 should be protected against this heat transfer.

[0032] To avoid these problems explained above, it is suggested to adapt the heatsink 1 of Figure 2 in the inventive manner shown in Figure 3.

[0033] The inventive heatsink 1 of Figure 3 is similar to the one shown in Figure 2 but has been adapted to prevent the cooling fins 15 from transferring heat from the light source 2 to the center region where the driver housing 5 is arranged. The inventive further development can be seen when comparing both figures. While the heatsink 1 of Figure 2 comprises several cooling fins 15 extending from the center region to the circumference of the heatsink 1, most of this fins 15 are in the inventive embodiment of Figure 3 interrupted by a gap 16. This gap 16 divides the cooling fins 15 in a first portion 15a extending from the center region outwardly and a second portion 15b extending from the circumference of the heatsink 1 inwardly. Both cooling fin portions 15a and 15b are aligned with each other but prevented from exchanging heat by the gap 16.

[0034] The effect of the inventive measure can be seen

in Figure 4. Most heat during operation of the luminaire 10 is generated by the LED light source 2 and thus the temperature in the outer region of the heatsink 1 is relatively high. This temperature gradually decreases in inward direction but drops by a significant step in the gap region. In particular, the temperature of the inner cooling fin portions 15a is around 5 C° lower than the temperature of the outer cooling fin portions 15b in the area of the gap 16. This shows that the gaps 16 indeed significantly reduce a transfer of the heat from the LED light source 2 to the region of the driver and thus the problems mentioned above can be avoided.

[0035] The size and location of the gaps 16 can be adapted according to the actual design of the heatsink 1. However, since the gap 16 reduces the surface of the corresponding cooling fin 15, it is preferred that the gap width of the gap 16 is small. On the other hand, a minimum width of the gap 16 is required to block a heat transfer from one portion of the fin 15 to the other. Accordingly, the width of the gap 16 is preferably in the range between 3mm and 7mm, in particular around 5mm.

[0036] Further, the gap 16 is preferably located closer to the center region, i.e., the outer portion 15b of the cooling fin 15 being responsible for cooling the LED light sources 2 is larger than the inner portion 15a which is responsible for removing heat from the driver 3. In particular, the length ratio of both cooling fin portions 15a, 15b is around 1:4 but can be adapted in case the design of the heatsink 1 and/or the amount of heat generated by the LED light source 2 is changed.

[0037] As can also be seen in Figures 3 to 6, very few fin-like support elements 20 integrally extend from the center region to the outer region of the heatsink 1 where the LED light sources 2 are arranged. These support elements 20 are required to integrally connect the outer part with the inner part of the heatsink 1 which otherwise would be split in two separate components. A design of the heatsink 1 in one piece is, however, preferred with respect to the mounting of the complete luminaire 10. On the other hand, the total number of such support elements 20 should be kept low since these elements 20 again increase the thermal coupling between both regions of the heatsink 1. In the embodiment shown in the Figures, 4 support elements 20 are used.

[0038] Regarding these support elements 20, a preferred design of them is shown in the cross sectional view of Figure 6. As it can be seen, a diagonal cut 21 splits each support element 20 in an upper portion 20a and a lower portion 20b. While the upper portion 20a extends from an upper area of the central portion to the outer region of the heatsink 1, the lower portion 20b merely projects outwardly with a triangular shape from the circumference of the central opening 1a but is not in contact with LED light sources 2. The upper portion 20a further comprises the shown stepped configuration resulting in a minimum amount of material which thermally connects the outer portion of the heatsink 1 with the inner portion. This design of the support elements 20 ensures a reliable

support for the outer portion of the heatsink 1 while at the same time an undesired heat transfer is avoided or at least reduced to a minimum.

[0039] Accordingly, the inventive structure of the heatsink 1 helps to avoid the heat transfer problems mentioned above. In particular, overheating of an LED driver or other components required for an emergency lighting can be avoided even in situations where the luminaire is operated at high ambient temperatures.

[0040] Obviously, the shown heatsink can be adapted in several aspects without departing from the inventive concept. In particular, the idea of using an integral heatsink for cooling both a light source and a driver but avoiding or at least suppressing a transfer of heat between both regions of the heatsink could also be realized in longitudinal heatsink designs or other structures.

Claims

1. Heatsink (1) for a luminaire (10), said heatsink (1) comprising

- a first portion being adapted for arranging a lightsource driver (3), an emergency lighting unit or a housing (5) for accommodating a light source driver (3) or an emergency lighting unit, and
- a second portion being integrally formed with the first portion and adapted for arranging a light source (2),

wherein at least some cooling fins (15) extending from the first portion to the second portion are interrupted by a gap (16), **characterized in that** the heatsink (1) further comprises support elements (20) extending from the first portion of the heatsink (1) to the second portion, wherein the support elements (20) comprise a cut (21) which splits each support element (20) in two portions (20a, 20b) and wherein the cut (21) diagonally extends through the support element (20).

2. Heatsink according to claim 1, wherein each gap (16) divides a corresponding cooling fin (15) in a first cooling fin portion (15a) and a second cooling fin portion (15b), both portions being aligned with each other.

3. Heatsink according to claim 2, wherein the gap (16) separates both cooling fin portions (15a, 15b) by a distance of around 3 to 7 mm, preferably by around 5 mm.

4. Heatsink according to claim 2 or 3, wherein the length ratio between the first cooling fin portion (15a) and the second cooling fin portion (15b) is around 1:4.

5. Heatsink according to one of the preceding claims, said heatsink (1) having a circular configuration with the first portion forming a center portion of the heatsink (1) and the second portion forming an outer portion.
6. Heatsink according to claim 5, wherein the cooling fins (15) radially extend outwardly from the first portion of the heatsink (1) to the second portion, said cooling fins (15) being preferably evenly distributed over the circumference of the heatsink (1).
7. Heatsink according to claim 5 or 6, wherein the heatsink (1) comprises a central hole (1a) adapted for a being combined with a housing (5) for accommodating a light source driver (3) or an emergency lighting unit.
8. Heatsink according to one of claim 5 to 7, wherein the heatsink (1) comprises a receiving groove (1d), e.g. a circumferentially extending receiving groove, for receiving the light source (2).
9. Heatsink according to one of claims 1 to 4, said heatsink (1) having a longitudinal configuration with both portions extending parallel to each other.
10. Heatsink according to claim 9, said heatsink (1) comprising a further second portion being adapted for arranging a light source, wherein the first portion extends between both second portions.
11. A luminaire (10) having a main beam direction (B) comprising:
- a heatsink (1) according to one of the preceding claims,
 - a light source (2) mounted to the heatsink (1), and
 - a driver (3) configured to drive the light source (2).
12. A luminaire according to claim 11, wherein the light source (2) is a LED light source.

Patentansprüche

1. Kühlkörper (1) für einen Beleuchtungskörper (10), der Kühlkörper (1) umfassend
- einen ersten Abschnitt, der für das Anordnen eines Lichtquellentreibers (3), einer Notbeleuchtungseinheit oder eines Gehäuses (5) zur Unterbringung eines Lichtquellentreibers (3) oder einer Notbeleuchtungseinheit angeordnet

ist, und

- einen zweiten Abschnitt, der mit dem ersten Abschnitt einstückig ausgebildet und für das Anordnen einer Lichtquelle (2) angepasst ist,

wobei mindestens einige Kühlrippen (15), die sich vom ersten Abschnitt zum zweiten Abschnitt erstrecken, durch einen Spalt (16) unterbrochen werden, **dadurch gekennzeichnet, dass** der Kühlkörper (1) ferner Stützelemente (20) umfasst, die sich vom ersten Abschnitt des Kühlkörpers (1) zum zweiten Abschnitt erstrecken, wobei die Stützelemente (20) einen Schnitt (21) umfassen, der jedes Stützelement (20) in zwei Abschnitte (20a, 20b) teilt, und wobei der Schnitt (21) sich diagonal durch das Stützelement (20) erstreckt.

2. Kühlkörper nach Anspruch 1, wobei jeder Spalt (16) eine entsprechende Kühlrippe (15) in einen ersten Kühlrippenabschnitt (15a) und einen zweiten Kühlrippenabschnitt (15b) teilt, wobei beide Abschnitte miteinander ausgerichtet sind.
3. Kühlkörper nach Anspruch 2, wobei der Spalt (16) beide Kühlrippenabschnitte (15a, 15b) um einen Abstand von etwa 3 bis 7 mm, bevorzugt um etwa 5 mm, trennt.
4. Kühlkörper nach Anspruch 2 oder 3, wobei das Längenverhältnis zwischen dem ersten Kühlrippenabschnitt (15a) und dem zweiten Kühlrippenabschnitt (15b) etwa 1:4 ist.
5. Kühlkörper nach einem der vorhergehenden Abschnitte, wobei der Kühlkörper (1) eine kreisförmige Konfiguration aufweist, bei der der erste Abschnitt einen zentralen Abschnitt des Kühlkörpers (1) ausbildet und der zweite Abschnitt einen äußeren Abschnitt ausbildet.
6. Kühlkörper nach Anspruch 5, wobei die Kühlrippen (15) sich vom ersten Abschnitt des Kühlkörpers (1) zum zweiten Abschnitt radial nach außen erstrecken, wobei die Kühlrippen (15) bevorzugt gleichmäßig über den Umfang des Kühlkörpers (1) verteilt sind.
7. Kühlkörper nach Anspruch 5 oder 6, wobei der Kühlkörper (1) ein zentrales Loch (1a) umfasst, das für die Kombination mit einem Gehäuse (5) zur Unterbringung eines Lichtquellentreibers (3) oder einer Notbeleuchtungseinheit angepasst ist.
8. Kühlkörper nach einem der Ansprüche 5 bis 7, wobei der Kühlkörper (1) eine Aufnahmenut (1d), z. B. eine sich am Umfang erstreckende Aufnahmenut, für das Aufnehmen der Lichtquelle (2) umfasst.

9. Kühlkörper nach einem der Ansprüche 1 bis 4, wobei der Kühlkörper (1) eine Längskonfiguration aufweist, bei der sich beide Abschnitte parallel zueinander erstrecken.
10. Kühlkörper nach Anspruch 9, wobei der Kühlkörper (1) einen weiteren zweiten Abschnitt für das Anpassen zum Anordnen einer Lichtquelle umfasst, wobei der erste Abschnitt sich zwischen beiden zweiten Abschnitten erstreckt.
11. Ein Beleuchtungskörper (10) mit einer Hauptstrahlrichtung (B), umfassend:
einen Kühlkörper (1) nach einem der vorhergehenden Abschnitte, eine Lichtquelle (2), die am Kühlkörper (1) montiert ist, und einen Treiber (3), der konfiguriert ist, die Lichtquelle (2) anzutreiben.
12. Beleuchtungskörper nach Anspruch 11, wobei die Lichtquelle (2) eine LED-Lichtquelle ist.

Revendications

1. Dissipateur thermique (1) pour un luminaire (10), ledit dissipateur thermique (1) comprenant une première partie étant adaptée pour agencer un circuit de commande de source de lumière (3), une unité d'éclairage de secours ou un logement (5) pour loger un circuit de commande de source de lumière (3) ou une unité d'éclairage de secours, et une seconde partie faisant partie intégrante de la première partie et adaptée pour l'agencement d'une source de lumière (2), dans lequel au moins certaines ailettes de refroidissement (15) s'étendant de la première partie à la seconde partie sont interrompues par un espace (16), **caractérisé en ce que** le dissipateur thermique (1) comprend en outre des éléments de support (20) s'étendant de la première partie du dissipateur thermique (1) à la seconde partie, dans lequel les éléments de support (20) comprennent une découpe (21) qui sépare chaque élément de support (20) en deux parties (20a, 20b) et dans lequel la découpe (21) s'étend en diagonale à travers l'élément de support (20).
2. Dissipateur thermique selon la revendication 1, dans lequel chaque espace (16) divise une ailette de refroidissement correspondante (15) en une première partie d'ailette de refroidissement (15a) et une seconde partie d'ailette de refroidissement (15b), les deux parties étant alignées l'une avec l'autre.
3. Dissipateur thermique selon la revendication 2, dans lequel l'espace (16) sépare les deux parties d'ailettes de refroidissement (15a, 15b) une distance

d'environ 3 à 7 mm, de préférence d'environ 5 mm.

4. Dissipateur thermique selon la revendication 2 ou 3, dans lequel le rapport de longueur entre la première partie d'ailette de refroidissement (15a) et la seconde partie d'ailette de refroidissement (15b) est d'environ 1:4.
5. Dissipateur thermique selon l'une quelconque des revendications précédentes, ledit dissipateur thermique (1) ayant une configuration circulaire, la première partie formant une partie centrale du dissipateur thermique (1) et la seconde partie formant une partie extérieure.
6. Dissipateur thermique selon la revendication 5, dans lequel les ailettes de refroidissement (15) s'étendent radialement vers l'extérieur de la première partie du dissipateur thermique (1) à la seconde partie, lesdites ailettes de refroidissement (15) étant de préférence uniformément réparties sur la circonférence du dissipateur thermique (1).
7. Dissipateur thermique selon la revendication 5 ou 6, dans lequel le dissipateur thermique (1) comprend un trou central (1a) adapté pour être combiné à un logement (5) pour loger un circuit de commande de source de lumière (3) ou une unité d'éclairage de secours.
8. Dissipateur thermique selon l'une des revendications 5 à 7, dans lequel le dissipateur thermique (1) comprend une rainure de réception (1d), par exemple une rainure de réception s'étendant de manière circconférentielle pour recevoir la source de lumière (2).
9. Dissipateur thermique selon l'une des revendications 1 à 4, ledit dissipateur thermique (1) ayant une configuration longitudinale avec les deux parties s'étendant parallèlement l'une à l'autre.
10. Dissipateur thermique selon la revendication 9, le dissipateur thermique (1) comprenant une seconde partie supplémentaire adaptée pour l'agencement d'une source de lumière, dans lequel la première partie s'étend entre les deux secondes parties.
11. Luminaire (10) ayant une direction de faisceau principal (B) comprenant :
- un dissipateur thermique (1) selon l'une des revendications précédentes,
une source de lumière (2) montée sur le dissipateur de chaleur (1), et
un circuit de commande (3) configuré pour commander la source de lumière (2).

12. Luminaire selon la revendication 11, dans lequel la source de lumière (2) est une source lumineuse à DEL.

5

10

15

20

25

30

35

40

45

50

55

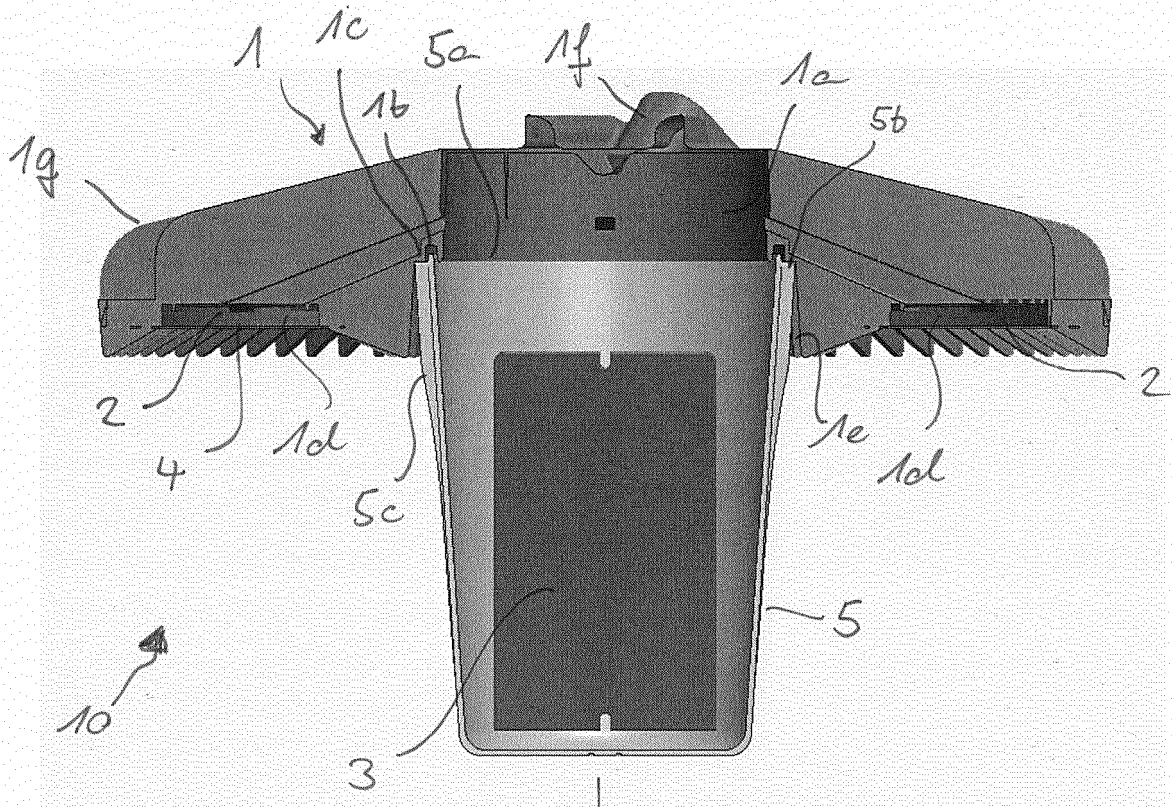

Fig. 1

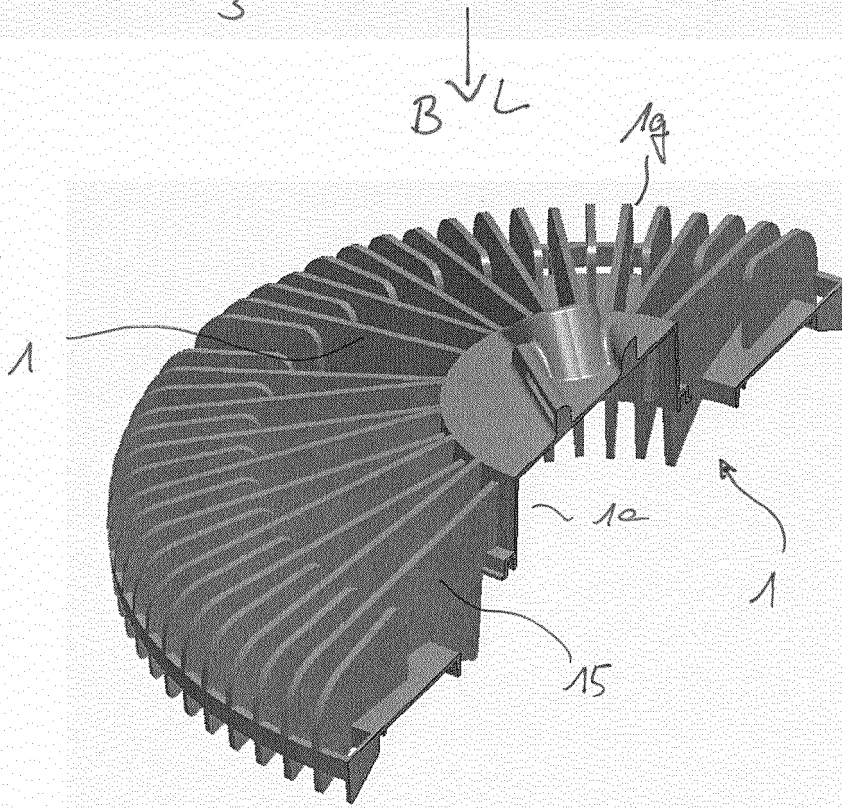

Fig. 2

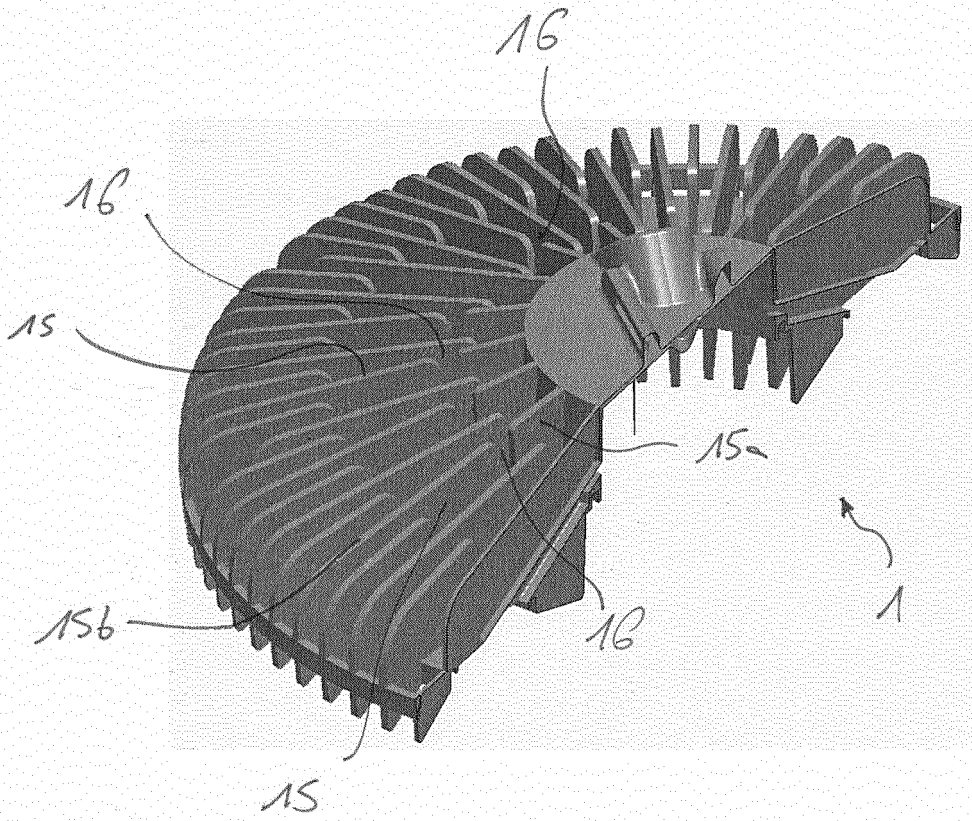

Fig. 3

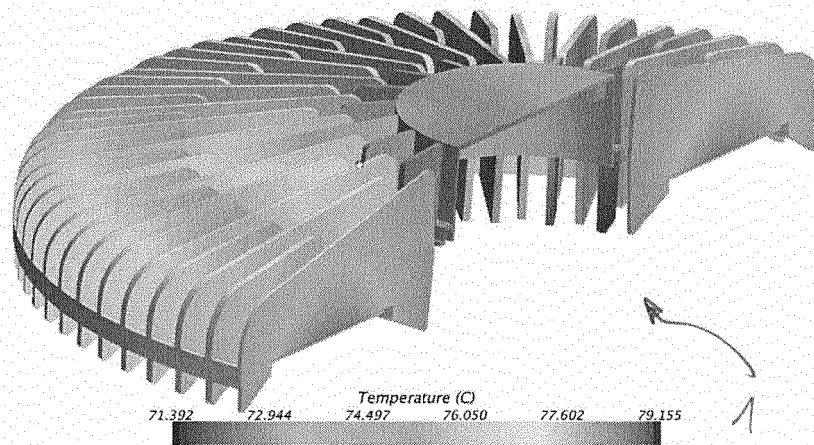
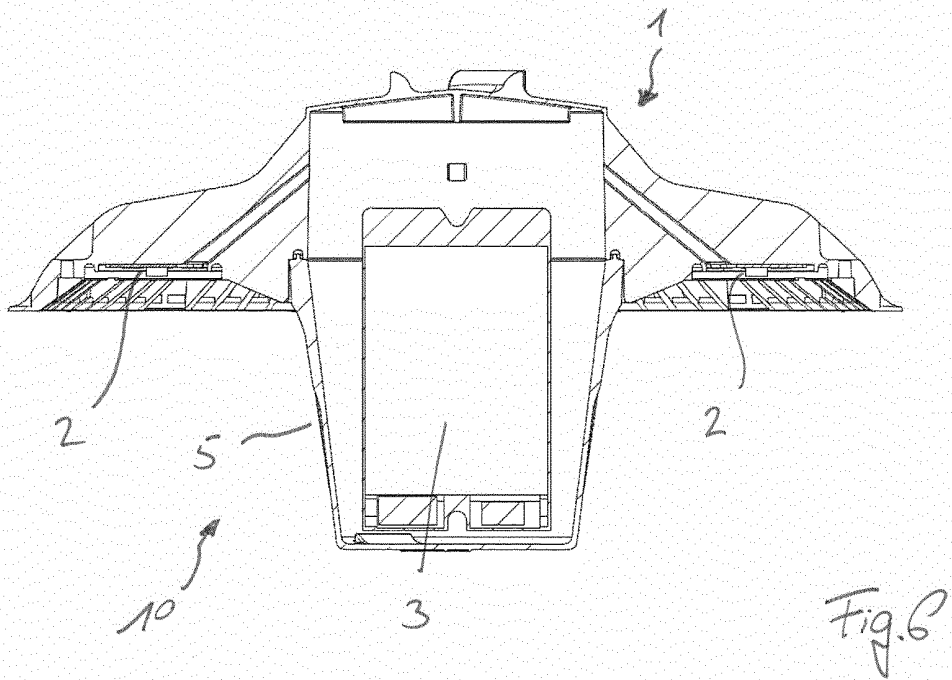
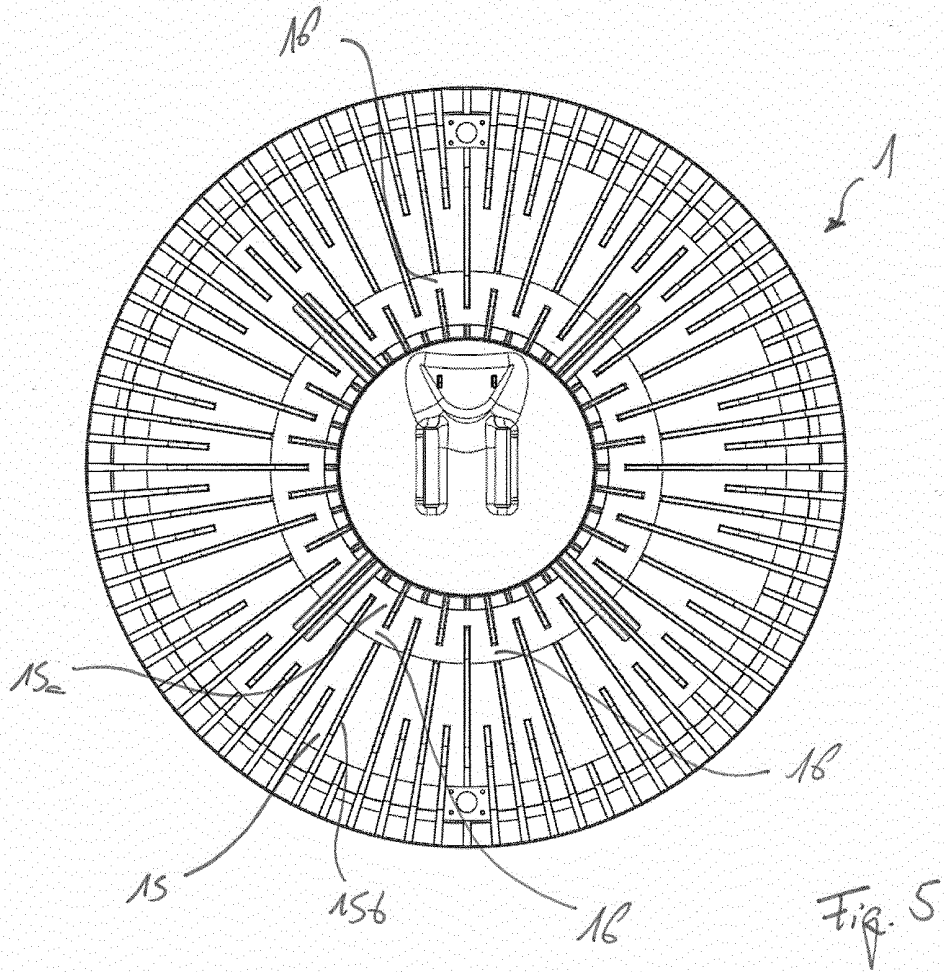

Fig. 4



REFERENCES CITED IN THE DESCRIPTION

This list of references cited by the applicant is for the reader's convenience only. It does not form part of the European patent document. Even though great care has been taken in compiling the references, errors or omissions cannot be excluded and the EPO disclaims all liability in this regard.

Patent documents cited in the description

- WO 2015186016 A1 [0004]
- WO 2013057433 A1 [0005]
- US 2010226139 A [0006]