

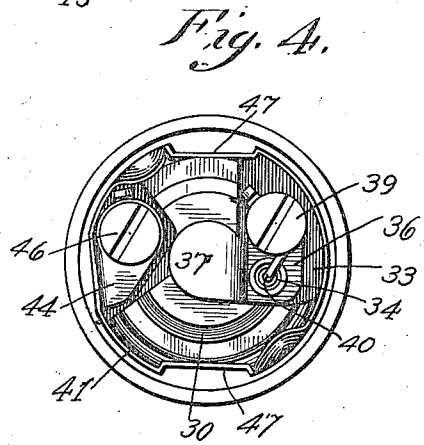

R. B. BENJAMIN.  
 SEPARABLE ATTACHMENT PLUG.  
 APPLICATION FILED NOV. 21, 1908.

1,154,963.

Patented Sept. 28, 1915.  
 2 SHEETS—SHEET 2.

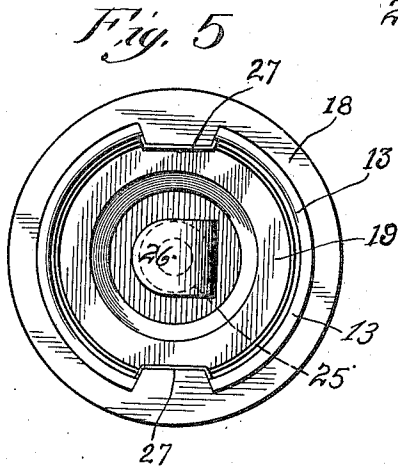
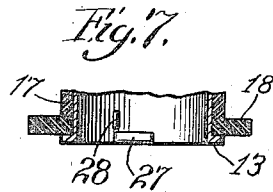
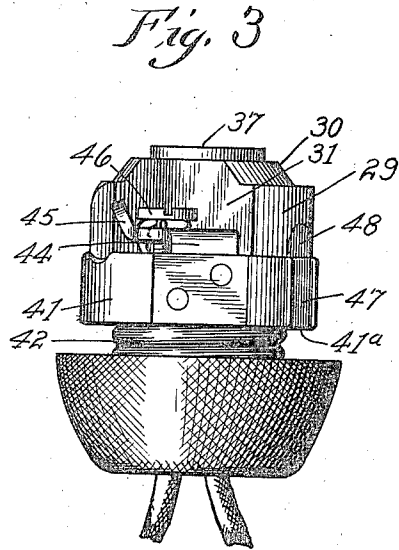
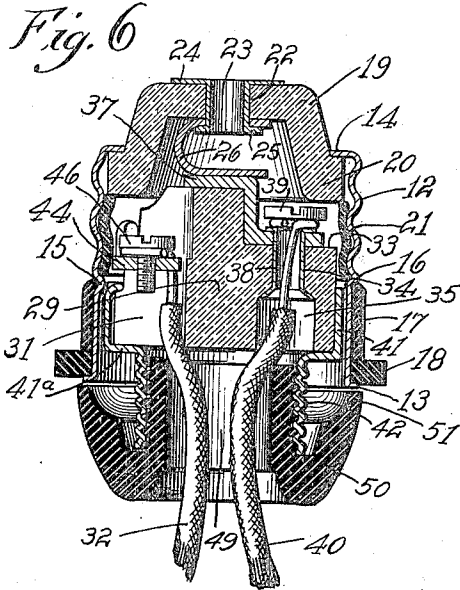

Witnesses:  
*Wm. M. Haanel*  
*Chas. L. Hopkins*

Inventor:  
*Reuben B. Benjamin,*  
 By *Jones, Addington & Ames,*  
 Attorneys.

# UNITED STATES PATENT OFFICE.

REUBEN B. BENJAMIN, OF CHICAGO, ILLINOIS, ASSIGNOR TO BENJAMIN ELECTRIC MANUFACTURING COMPANY, OF CHICAGO, ILLINOIS, A CORPORATION OF ILLINOIS.

## SEPARABLE ATTACHMENT-PLUG.

1,154,963.

Specification of Letters Patent. Patented Sept. 28, 1915.

Application filed November 21, 1908. Serial No. 463,764.

*To all whom it may concern:*

Be it known that I, REUBEN B. BENJAMIN, a citizen of the United States, residing at Chicago, in the county of Cook and State of Illinois, have invented new and useful Improvements in Separable Attachment-Plugs, of which the following is a full, clear, concise, and exact description, reference being had to the accompanying drawing, forming a part of this specification.

This invention relates to separable attachment plugs, which, as is well known, consist of two members, one of which is provided with contacts for coöperation with the contacts of the socket, and the other of which carries binding terminals, these members being detachably connected together in such manner that, when assembled, electrical connection is made between the contacts on the one member and the binding terminals on the other member. Such plugs are of particular use in cases wherein it is desirable for an electric translating device, such as a fan, motor or the like, to be more speedily connected to, and disconnected from, a socket than is possible when using a one-piece plug.

Separable plugs, as hitherto constructed, have been subject to the disadvantage that considerable force was necessary to detach one portion from the other. This was owing to the fact that, in most cases, the plug members telescoped together, a contact piece on one member engaging between spring contacts on the other; so that the frictional resistance, and the resistance to bending, of the spring contacts had to be overcome before one member could be separated from the other. When this frictional resistance and resistance to bending were overcome, the members separated with a jerk, and this jerk, being often repeated, was liable to cause considerable deterioration of the socket and the parts connected thereto.

One of the objects of my invention is the obviation of the above disadvantage, to which end I so construct the plug that the interlocking of the members thereof may be effected by a revolving movement of one member relative to the other.

Another object of my invention is the

provision of a simple and reliable separable plug of economical construction and neat appearance.

For a full understanding of my invention, reference is to be had to the accompanying description and drawings, in which I have shown a form of device embodying my invention.

Figure 1 is an elevation of the device with the separable members interconnected; Fig. 2 shows these parts separated from each other; Fig. 3 shows the body, or binding terminal carrying member, separated from the other member and revolved to present the side opposite that seen in Fig. 2; Fig. 4 is a plan view of this body member; Fig. 5 is an inverted plan view of the other member; Fig. 6 is a vertical section on the line 6-6 of Fig. 1; and Fig. 7 is a reduced fragmentary view of one of the details of the device.

Like characters of reference refer to like parts throughout the specification and drawings.

In the form of my invention illustrated herein, the part which carries the socket-terminal-engaging contacts consists of a shell 10, adapted for insertion into the socket, and a body 11, which carries binding terminals to which are secured the flexible conductors leading to the fan or other electric current consuming device, the body 11 being removably inserted in the shell 10, as will be hereinafter fully described.

The shell 10 comprises a metallic sleeve 12 having screw threads formed thereon adjacent its upper end for engaging the internal threads of an ordinary Edison socket. This sleeve 12 is formed with an inwardly turned upper end flange 14 and an outwardly turned lower end flange 13, and with an inwardly extending circumferential bead 15 and an outwardly extending circumferential bead 16 intermediate its ends, the beads 15 and 16 being preferably located adjacent each other and immediately below the termination of the screw threaded portion of the sleeve. Surrounding the lower portion of the sleeve 12, and held between the flange 14 and the bead 16, is a ring 17, formed of insulating material, such as hard rubber or the like, and having an

outwardly extending flange 18 which is preferably knurled at its periphery to provide a firm hold for the fingers of the user. A cup-shaped block 19 of insulating material is inserted in the upper end of the sleeve 12 and has formed thereon an outwardly extending flange 20 which abuts against the flange 14. The block 19 is held in place by an insulating ring 21 located between the lower side of its flange 20 and the bead 15 of the sleeve 12.

The block 19 is formed with a central aperture 22 in which is secured the center contact of the plug. The center contact consists of a tubular member 23 which passes through the aperture 22 and is bent outward to form a flange 24 outside the block 19. The tubular member 23 is also formed with a flange 25, within the block 19. One end of a resilient inner contact 26, which preferably consists of a substantially U-shaped plate of spring brass, surrounds the tubular member 23 and is clamped between the flange 25 and the inner side of the block 19.

The sleeve 12 is formed with inwardly extending bayonet projections 27 adjacent its lower edge, said projections tapering slightly upward to one side for a purpose to be hereinafter described. A small excrescence 28 is formed adjacent the thicker end of one of the projections 27.

By building up the shell as above described, instead of, as is usual in earlier forms of separable plugs, constructing it of a single hollow porcelain part having a sleeve contact secured thereon, a larger space is provided within the shell, thus enabling the body to be made of larger proportions than has hitherto been considered possible. This is an important advantage of the plug since it enables the insulating properties of the body to be increased, and the binding terminals to be so located on the body as to be readily accessible.

The body 11 comprises an insulating base 29 of less diameter than the internal diameter of the sleeve 12 and having a tapered portion 30 at its upper end. The base 29 is formed with a side recess 31 extending from one end thereof to the other for containing the end of the conductor 32. A second recess 33 is also formed at the upper end of the plug, a passage 34, which opens at one end into the recess 33, extending through the plug and having an enlarged portion 35 at the end thereof adjacent the lower face of the plug.

Located in the recess 33 is the shank 36 of the end contact 37 of the body, the end contact resting upon the upper end of the base 29, and having its shank bent downwardly and outwardly to snugly fit in the recess 33. The shank 36 has an aperture 65 formed therein, which, when the end con-

tact is in position, registers with the passage 34, and a hollow metallic rivet 38 is passed through this aperture and the passage 34 and flanged over at one end against the shank 36 and at the other end against the shoulder formed by the enlargement 35 of the passage 34. This rivet securely holds the shank 36 in position in the recess 33. The shank 36 is further provided with a binding terminal 39 to which is secured the end of the conductor 40 which is passed upwardly through the enlargement 35 and the hollow rivet 38.

Surrounding the lower end of the base 29 is a cup 41 constructed of brass or other electric current conducting material and of a diameter slightly less than the inner diameter of the sleeve 12. The cup 41 is reduced at its lower end to form a shoulder 41<sup>a</sup> and a downwardly extending collar 42, which latter is screwthreaded. The base is secured in the cup by bending portions of the upper edge of the latter over ledges formed upon the base. Secured, by rivets, or otherwise, to the cup 41, and so located as to enter the recess 31, is a conductor plate 44 preferably so shaped that sufficient room is left between it and the inner face of the recess 31 to allow of the passage of the bared end of the conductor 32 therethrough, an upwardly bent lug 45 being formed on the conductor plate 44 for the purpose of precluding any chance of the conductor slipping around the conductor plate to the outside thereof. A binding terminal 46 is screwed into the conductor plate 44 and clamps the end of the conductor 32. The cup 41 is bent inwardly at one or more points at its periphery to form recesses 47, such recesses being of the same number as the bayonet projections 27 on the sleeve 12 of the shell 10, and so located as to register with the projections 27 when the body 10 is inserted in the shell 10. Flat places 48 are formed upon the base 29 in order that the bending in of the cup 41 to form the recesses 47 may be possible. Screwed into the collar 42 is the screw-threaded neck 49 of the handle 50, which is constructed of hard rubber or other insulating material, and is formed with an upturned flange or skirt 51 which incloses the collar 42. The conductors 32 and 40 pass through the neck 49, which latter is of such length that, when screwed firmly into the collar 42, it clamps the conductors against the lower end of the base 29 and precludes any chance of their detachment from the binding terminals by an accidental jerk or the like.

In using the plug, the shell 10 is screwed into the socket until the flange 24 of its center contact makes connection with the center contact of the socket. When thus connected, the shell 10 cooperates with the Edison socket to form a socket of a differ-

ent internal configuration, and, of the socket so formed, 26 is one contact and the lower portion of the sleeve 12 the other. The body 11 then becomes a plug, the end  
5 contact 37 and cup 41, to which the conductors 40 and 32 are respectively connected, engaging the inner contact 26 and the inner face of the sleeve 12.

The body 11 and shell 10 are preferably so  
10 proportioned that, when the body is inserted in the shell (the projections 27 of the shell entering the recesses 47 of the body), the end contact 37 will engage the inner contact 26 of the shell slightly before the projections  
15 27 reach the lower end of the recesses 47, so that it is necessary to compress the inner contact 26, which is made resilient to that end, before the projections can pass beyond the lower end of the cup 41. When the body  
20 11 has been thus forced against the inner contact 26 until the projections 27 have passed through the recesses 47 and beyond the lower end of the cup, it is turned relatively to the shell so that the projections 27  
25 engage beneath the shoulder 41<sup>a</sup> of the cup 41 and are held in such engagement by reason of the resilience of the inner contact 26. The upward slope of the projections 27 causes the end contact 37 to be forced more  
30 firmly against the inner contact 26 when the body is rotated. The stop 28 limits the possible turning movement of the body in the shell.

In order to connect the body to the shell,  
35 all that is necessary is that the body be firmly pushed into place and given a slight twist, while a slight twist in the opposite direction is sufficient to detach it.

Having thus described my invention, what  
40 I claim as new and desire to secure by Letters Patent, is—

1. In a separable plug; a body comprising a base, a cup-shaped contact member surrounding the lower end of said base and  
45 carrying a binding terminal and an end contact secured to said base and carrying a second binding terminal; and a shell for receiving said body, said shell comprising a contact sleeve for engaging said cup-shaped  
50 contact and an inner contact for engaging said end contact.

2. In a separable plug; a shell comprising a conductor sleeve screw threaded at its upper end, an insulating block within said  
55 sleeve and projecting beyond the end thereof, an outer end contact carried by said block, an inner contact carried by said block and electrically connected with the outer end contact, an insulating ring carried within  
60 the upper end of said sleeve and an insulating ring carried by the lower end of said sleeve outside the same; and a body insertible into said shell and having contacts for engaging said sleeve and said inner contact,  
65 and binding terminals carried by said body.

3. An attachment plug comprising a screw shell having at its forward end an insulating head carrying a contact plate and a contact spring connected therewith, an inner shell, an insulating block within said  
70 shell carrying a contact plate adapted to engage the contact spring, means for detachably securing the shells together and electrical connections.

4. A screw shell having at its forward end  
75 an insulating head, a contact plate on the outer side of said head, a contact spring on the inner side thereof and an electrical connection between said contact plate and contact spring.  
80

5. An attachment plug comprising an outer member having at its forward end an insulating head carrying a contact plate and a contact spring connected therewith, an inner member comprising an inner shell and  
85 an insulating block carrying a contact plate adapted to engage the contact spring; means for detachably connecting said members together and electrical connections.

6. An attachment plug comprising an  
90 outer member having at its forward end an insulating head carrying a contact plate and a contact spring connected therewith, an inner member comprising an inner shell and an insulating block carrying a contact  
95 plate adapted to engage the contact spring and binding screws, electrical connections from one binding screw to the shells and electrical connections from the other binding  
100 screw to the contact plate on the insulating head.

7. An attachment plug comprising a screw shell having at its forward end an insulating head carrying a contact plate, an inner shell detachably engaging the screw shell,  
105 an insulating block in the inner shell, binding screws carried by said block and electrical connections from one binding screw to the screw shell and from the other binding screw to said contact plate.  
110

8. An attachment plug comprising a screw shell having at its forward end an insulating head carrying a contact plate, an inner shell detachably engaging the screw shell, an insulating block in the inner shell,  
115 binding screws carried by said block, a contact plate connecting one binding screw with the inner shell and electrical connections from the other binding screw to the contact plate on the insulating head.  
120

9. In an attachment plug the combination with a screw shell having an insulating head carrying a contact plate and a contact spring, of an inner shell detachably engaging the screw shell, an insulating block in  
125 the inner shell carrying a contact plate adapted to engage the contact spring and electrical connections.

10. In an attachment plug, the combination with an outer member comprising a  
130

screw shell and an insulating head carrying  
a contact plate and contact spring, of an  
inner member comprising an inner shell and  
an insulating block carrying a contact plate  
5 adapted to engage the contact spring and  
electrical connections.

In witness whereof, I have hereunto sub-

scribed my name in the presence of two wit-  
nesses.

REUBEN B. BENJAMIN.

Witnesses:

CHARLES G. COPE,

CHARLES L. HOPKINS.