

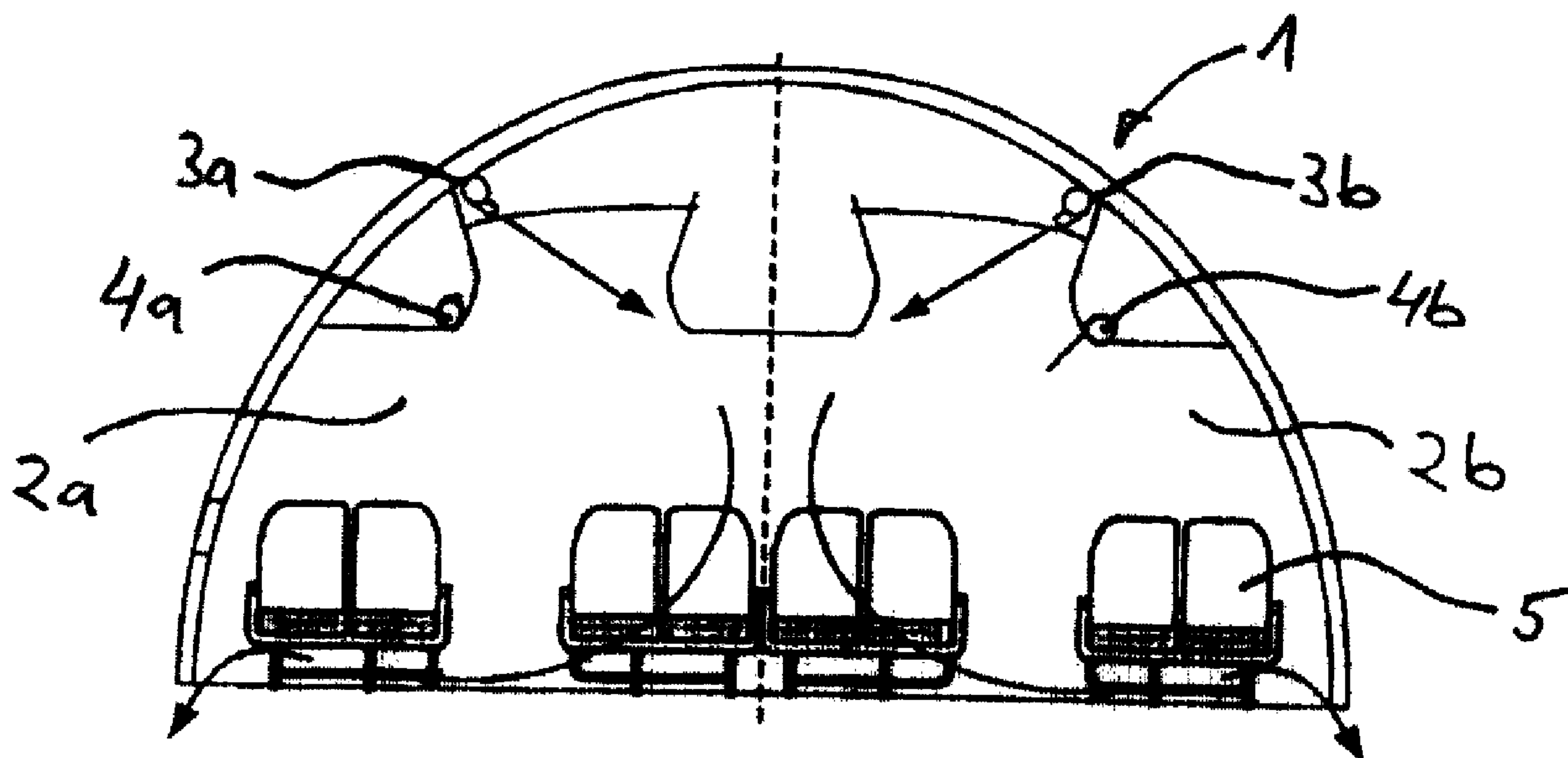

(22) Date de dépôt/Filing Date: 2004/12/21
 (41) Mise à la disp. pub./Open to Public Insp.: 2005/06/29
 (45) Date de délivrance/Issue Date: 2013/01/29
 (30) Priorité/Priority: 2003/12/29 (DE103 61 392.7)

(51) Cl.Int./Int.Cl. *F24F 3/00* (2006.01),
B60H 1/22 (2006.01), *B64D 13/06* (2006.01),
B64D 13/08 (2006.01)
 (72) Inventeurs/Inventors:
 MARKWART, MICHAEL, DE;
 ARNOLD, KLAUS, DE;
 BRACKER, FRANK, DE;
 LOHMAR, JENS, DE;
 SCHERER, THOMAS, DE;
 SCHWAN, TORSTEN, DE
 (73) Propriétaire/Owner:
 AIRBUS OPERATIONS GMBH, DE
 (74) Agent: GOWLING LAFLEUR HENDERSON LLP

(54) Titre : SYSTEME DE DISPERSION D'AIR
 (54) Title: AIR DISPERSION SYSTEM



(57) Abrégé/Abstract:

An air dispersion system has a main supply line, a plurality of air outlets, which are connected via respective air exhaust routes to the main supply line, and at least one heating element, which is associated with at least one of the air outlets and can temper the air in the exhaust route of this air outlet.

Abstract Of The Disclosure

An air dispersion system has a main supply line, a plurality of air outlets, which are connected via respective air exhaust routes to the main supply line, and at least one heating element, which is associated with at least one of the air outlets and can temper the air in the exhaust route of this air outlet.

AIR DISPERSION SYSTEM

Field of the invention

5

The invention relates to an air dispersion system or air distribution system, e.g. for homogenizing a thermal load dispersion or distribution within a chamber, in particular, the heat dispersion or distribution within a cabin of an aircraft.

10

Technical background

In order to control or regulate the cabin temperature of an aircraft, the cabin typically is subdivided into a certain number of temperature zones. However, it is also possible
15 that the distribution of the heat sources and heat sinks in the zone is inhomogeneous. This is the case, for example, when the seating density within the zone varies. A high density of passengers forms a heat source, while an empty door area represents a heat sink. The result is that in regions with a heat source, a warmer temperature prevails and, conversely, in a region with heat sinks, a colder temperature prevails. An
20 inhomogeneous temperature distribution within the zone, however, connotes a restriction of thermal comfort.

Whether there is an inhomogeneous distribution of the heat sources and heat sinks depends, then, on the individual arrangement of the seat layout. This can appear
25 differently for each aircraft customer.

In order to counteract the inhomogeneity of the thermal load distribution within a temperature zone, typically the supply amount through the air outlets is reduced at the positions with colder supply temperature, whereby the temperature level of the
30 corresponding cabin part is raised. One disadvantage of reducing the air volume, however, is that the air distribution system must be calibrated anew, which is connected with a large expenditure of time.

DE 43 35 152 C1 discloses a cabin air circulation system for air conditioning of the fuselage of a passenger aircraft. This cabin air circulation system regulates the fresh air volume flow including the temperature monitoring for the fuselage pressure of a passenger aircraft and allows a high degree of purity of the air-conditioned air. The
5 temperature regulation takes place by means of a separate heat exchanger in the circulating air.

DE 195 90 773 C1 discloses a ventilation system for reducing the concentration of impurities in passenger areas, in particular, in the smoking zones.

10

DE 44 25 871 C2 discloses a method for air conditioning two passenger decks of an aircraft. For temperature adjustment, air conditioning systems are used, respectively for an upper deck circuit and a main deck circuit. In each air conditioning system, the drawn air removed from the drive works is cooled. The air conditioning aggregates,
15 in addition, are connected to an exterior air line, in order to cool the hot drawn air from the drive works with external air during operation.

Summary of the invention

20 According to an exemplary embodiment of the present invention, an air dispersion system is provided which may have at least one main supply line, through which air is distributed via respective exhaust routes with a predetermined pressure to air outlets and is blown into respective temperature zone regions. The air dispersion system of the present invention further has at least one heating element, which is associated with
25 at least one of the air outlets and tempers the air, which flows in a corresponding exhaust route of this air outlet, to a predetermined temperature, and the heated air can blow out into a corresponding region.

It is believed that this air dispersion system according to an exemplary embodiment of
30 the present invention may allow for a homogenous temperature distribution in each zone.

According to a further embodiment of the invention, the air dispersion or distribution system has auxiliary supply lines, which branch off from the main supply line, whereby the individual air outlets are supplied with air individually via an auxiliary line.

5

In this manner, for example, the heating element can be mounted in the area of the auxiliary supply line, in order to heat the air flowing therethrough, before it exits into the respective region via the air outlet.

10 Since each temperature zone is supplied by an air outlet (or a group of air outlets), with failure or malfunction of one auxiliary supply line, it is believed that only the corresponding air outlet (or the group of air outlets) is affected, and the manner of functioning of the remaining air outlets, which are not supplied via this auxiliary supply line, remains essentially maintained.

15

According to another exemplary embodiment of the present invention, the air supply takes place from air outlet to air outlet, which may have the advantage that the air dispersion system has a simpler structure.

20 According to still another exemplary embodiment of the present invention, the heating element is mounted, for example, on the air discharge side and/or the air inlet side of an air outlet, in order to heat the air flowing therethrough, before it is blown out into a corresponding region.

25

Detailed description of exemplary embodiments

Further exemplary embodiments of the invention will be described with reference to the accompanying figures. In the figures:

30

Figure 1 shows a cross section through an aircraft cabin;

Figure 2 shows a schematic view of the air dispersion system of the air craft cabin shown in Figure 1 according to a first exemplary embodiment;

5 Figure 3 shows a schematic view of the air dispersion system of the aircraft cabin shown in Figure 1 according to a second exemplary embodiment;

Figure 4 shows a installation point for the heating system with the air dispersion system shown in Figure 3; and

10 Figure 5 shows a side view from the right of the air outlet shown in Figure 4.

In the figures, the same or similar elements will be provided with the same reference numerals.

15 Fig. 1 shows a section through an aircraft cabin 1, which is subdivided into a certain number of temperature zones 2. In Fig. 1, for example, in the left half, a first temperature zone 2a is shown and in the right half, a second temperature zone 2b is shown.

20 Via air outlets 3, the temperature zones 2 are supplied with air. In particular, for example, air is blown into the temperature zone 2a via the air outlet 3a, and via the air outlet 3b, air is blown into the temperature zone 2b.

25 The air outlets 3a, 3b shown in Fig. 1 are arranged in the upper region (ceiling region) of the aircraft cabin, but, however, can be formed at any other desired position within the cabin.

30 In addition, Fig. 1 shows sensors 4, for example, temperature sensors 4a, 4b, which are arranged respectively in each temperature zone 2a, 2b in the upper region (ceiling region) of the cabin. The temperature zones can be arranged alternatively virtually at any position within the temperature zone. The sensor may be positioned within the temperature zone 2 at a position, which corresponds to the mean temperature of the

temperature zone (not thermal load). This temperature results naturally from the thermal load within the temperature zone. With these temperature sensors 4a, 4b, the temperature within a temperature zone 2 is typically measured at the point, which corresponds with the mean temperature in the zone. The engaged local temperatures
5 are affected, therefore, by the occurring thermal load (sources and sinks).

Fig. 1 further shows seats, for example, for receiving passengers. In one region of the aircraft cabin, in which many seats 5 occupied with passengers is located, generally the temperature of this temperature zone 2 is greater than the temperature in a region
10 of the cabin, in which few or no occupied seats 5 are located (a minimal seating density), for example, in the area of the door. The region with many seats, then, represents a heat source, for example, and the region at the door represents a heat sink.

15 Fig. 2 shows a schematic view of the air dispersion system in the aircraft cabin shown in Fig. 1 according to a first exemplary embodiment. This air dispersion system has a main supply line 6, via which multiple air outlets 3 are supplied with air. In the figure, for purposes of simplicity, the air outlet 3c according to Fig. 1 is shown. Each air outlet 3 is associated with a specific temperature zone 2. The air outlet 3a, then,
20 supplies the temperature zone 2a with air.

From the main supply line 6, a plurality of auxiliary supply lines 7 branch off, in order to supply the individual air outlets 3, respectively, with air. Therefore, the air exhaust routes of an air outlet 3 are defined by a corresponding auxiliary line 7 supplying it
25 with air and by an air route within the air outlet to the exhaust side of the air from the air outlet.

Alternatively, also only one group of air outlets 3 can be connected via an individual auxiliary supply line 7 with the main supply line 6, so that air is fed via the main
30 supply line 6 and the individual auxiliary supply line 7 to the group of air outlets.

Fig. 2 shows further a heating element 8, which is formed on the auxiliary supply line 7a, which supplies the air outlet 3a with air, which is blown heated into the temperature zone 2a, when the heating element 8 is in operation.

- 5 The heating element 8 can be a heating coil, for example, an electrical heater, or the like. The heating element can be located within the auxiliary supply line 7a, so that any air flow flowing through the auxiliary supply line 7a comes into contact with the heating element 8 and is thereby heated in an effective manner.
- 10 Alternatively, it is possible to mount the heating element 8 externally on the auxiliary supply line 7a, so that no direct contact with the air flowing in the auxiliary supply line 7a occurs. This has the advantage that the heating element 8 can be installed subsequently, without having to engage in the tube line system.
- 15 The air heated by the heating element 8 is fed to the air outlet 3a and is blown out via air nozzles 9a into the temperature zone 2a.

Fig. 3 shows a schematic view of an air dispersion system in the aircraft cabin shown in Fig. 1, according to a second exemplary embodiment.

20

- With this air dispersion system, a main supply line 6a branches off into a left supply line 6a and a right supply line 6b. Via the left supply line 6a, one group of air outlets is supplied with air (for purposes of simplicity, only one air outlet 3a is shown in the figure), whereby the air outlets are connected directly among each other, so that an air
- 25 supply from air outlet to air outlet is ensured. Each air outlet 3 has air nozzles 9, via which the air is blown out into a temperature zone 2.

- In contrast to the first embodiment, a heating element 8 is located directly on an air outlet 3a, in order to blow out heated air via air nozzles 9a. The heating element 8 can
- 30 be formed integrally with this on the air inlet side and/or air exhaust side of the air outlet 3a, in order to heat air first on the ends of an exhaust route of the air outlet 3a. In this manner, a heating element can be used with less heat output, compared with

the first exemplary embodiment, in which air already is heated relative to the beginning of an exhaust route.

5 The heating element 8 also can be formed separately and, for example, can be inserted into the air nozzles 9a of the air outlet 3a, whereby an exchange or a subsequent installation of the heating element 8 is very simple.

10 As shown in Fig. 3, only the air outlet 3a is provided with a heating element, so that only the air blown out from this air outlet is heated, and with reference to the supply air flow, air outlets 3 lying upstream or downstream are not affected; that is, air blown out through these air outlets is not heated.

15 In the first exemplary embodiment according to Fig. 2 and the second exemplary embodiment shown in Fig. 3, respectively, only one heating element 8 is shown by way of example. Depending on the requirements, however, also multiple air outlets 3 can be associated with a heating element 8 or multiple heating elements 8. The heating element 8, then, preferably is associated with an air outlet 3, in order to heat air in its exhaust route, when this air outlet 3 lies in a so-called heat sink. Such a heat sink can be formed, for example, by a door area.

20

Alternatively, the heating element also can be used in the standard manner for all of the air outlets 3, in order to temper accordingly the air blown out from the air outlets to a predetermined temperature, whereby the heat output of the heating element can be dispersed differently. Preferably, the heat output of the heating element, which is
25 located in the region of a heat sink, is greater than that of a heating element which is located in the region of a heat source. A heat source, for example, is formed by a high density of passengers.

30 As with the first exemplary embodiment, a heating element 8 can be a heating coil, an electric heater, or the like, for example.

The heat output of the heating element 8, for example, can be constant or adjustable both in the first exemplary embodiment as well as in the second exemplary embodiment.

5 Preferably, the heat output is regulated with the aid of the temperature sensors 4 shown in Fig. 1 (sensors 4a, and/or 4b), such that the exhaust route of an air outlet is heated, in order to raise the temperature level of regions that are too cold to the temperature level of the sensor point.

10 Fig. 4 shows a possible installation point for the heating element 8.

According to this exemplary embodiment, the heating element 8 is formed on the air exhaust side of the air outlet 3, so that the air blown out through the air nozzles 9 is heated. However, it also can be formed on an air inlet side of the air outlet 3.

15

When the air outlet 3 has multiple air nozzles 9, it is possible that the heating element 8 extends only over a part of the air nozzles 9.

20 Fig. 5 shows a side view of the outlet shown in Fig. 4 from the right. As shown in Fig. 5, the air outlet 3 is supplied from the right with air, which exits downwardly in part over the air nozzles 9 and in part, flows further to the left, in order to supply the air outlets lying downstream shown in Fig. 3. The exhaust air flow branching off downwardly from the supply air flow (that is, the air exhaust route) is heated by the heating element 8 formed directly on the air outlet 3, so that heated air is blown into a
25 corresponding temperature zone 2, which is associated with this air outlet 3.

The exhaust route of the air outlet 3, then, is heated by the heating element 8, so that heated air is blown into a temperature zone 2.

30 Although the invention is described above with reference to an aircraft cabin, it is obvious to the practitioner to modify the air dispersion system of the present

invention, such that it also can be used in a bus, a PKW, a train, etc., and such is contemplated as part of the invention disclosed herein.

5 It should be noted that the term "comprising" does not exclude other elements or steps and the "a" or "an" does not exclude a plurality. Also elements described in association with different embodiments may be combined.

10 The scope of the claims should not be limited by the preferred embodiments set forth in the foregoing examples, but should be given the broadest interpretation consistent with the description as a whole.

What is claimed is:

1. Cabin of an aircraft with an air dispersion system, said air dispersion system comprising:
 - a main supply line,
 - a plurality of air outlets connected to the main supply line via auxiliary supply lines and
 - at least one heating element,
 - wherein said at least one heating element being located directly at one of the air outlets for tempering the air at the air outlet side of this air outlet;
 - said at least one heating element being located in the area of a door in the cabin.
2. The cabin of claim 1,
 - wherein the respective air exhaust routes are auxiliary supply lines branching off from the main supply line, via which the plurality of the air outlets are supplied individually with air.
3. The cabin of claim 2,
 - wherein the heating element is mounted on at least one of the auxiliary supply lines, in order to enable warming of air in the respective auxiliary supply line.
4. The cabin of claim 1, further comprising:
 - an air supply from a second air outlet of the plurality of air outlets to a third air outlet of the plurality of air outlets.
5. The cabin of claim 1,
 - wherein the at least one heating element is formed directly on one of an air inlet side and air exhaust side of at least one fourth air outlet of the plurality of air outlets.

6. The cabin of claim 1,
wherein the at least one heating element has a constantly adjustable heat output.
7. The cabin of claim 1, further comprising:
at least one temperature sensor providing a temperature readout;
wherein, on the basis of the temperature readout, the heat output of the heating element is controlled to a predetermined value.
8. The cabin of claim 1, wherein
a volume flowing in the air dispersion system remains essentially constant.
9. Air dispersion system for homogenizing a thermal load dispersion within a cabin of an airplane, which cabin is subdivided into a number of temperature zones, comprising:
a main supply line;
a plurality of air outlets in every temperature zone, which are connected via respective air exhaust routes to the main supply line; and
at least one heating element, which is associated with at least one air outlet, wherein the air outlet lies in a heat sink and the at least one heating element is adapted to temper air in the respective exhaust route of this air outlet; and
at least one temperature sensor positioned at a position, which corresponds to the mean temperature of the temperature zone;
wherein each of the plurality of air outlet is associated with a specific temperature zone;
in order to allow for a homogeneous temperature distribution in each zone by regulating the heat output of the heating element.
10. An air dispersion system configured to disperse air in a cabin of an aircraft having a first temperature zone, the system comprising:
a main supply line in the cabin of the aircraft;

a plurality of air outlets connected via respective air exhaust lines to the main supply line, each of the air outlets having air nozzles for dispersing air therethrough at a predetermined pressure;

at least one first air outlet of the plurality of air outlets being associated with a first heating element configured to temper air flowing out of the first outlet to a predetermined temperature;

at least one second air outlet of the plurality of air outlets not associated with a heating element;

wherein the at least one first outlet is arranged in at least one first area of the first temperature zone having an inhomogeneity of a thermal load distribution; and

wherein a volume of air flowing in the air dispersion system remains essentially constant.

1/3

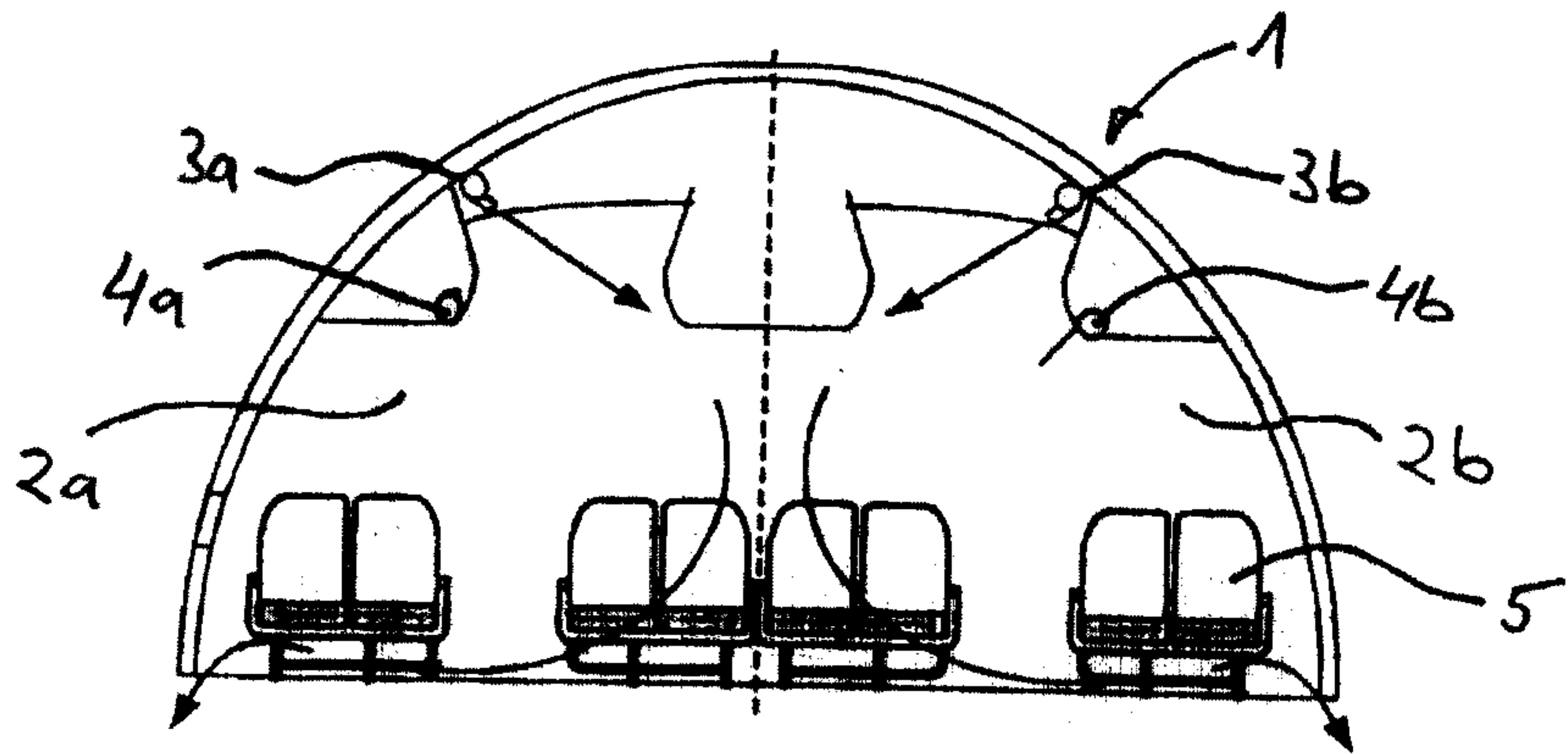

Fig. 1

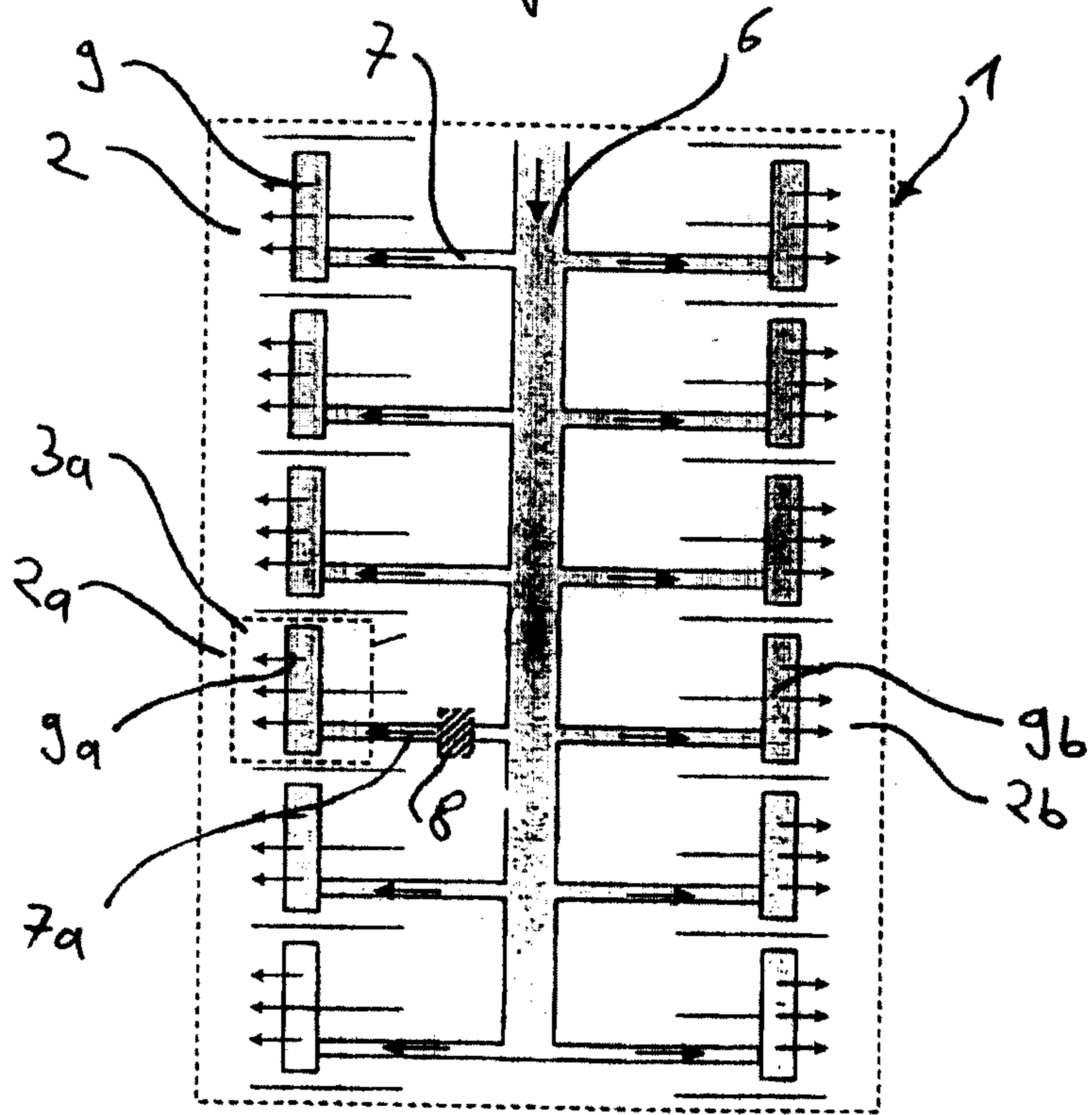

Fig. 2

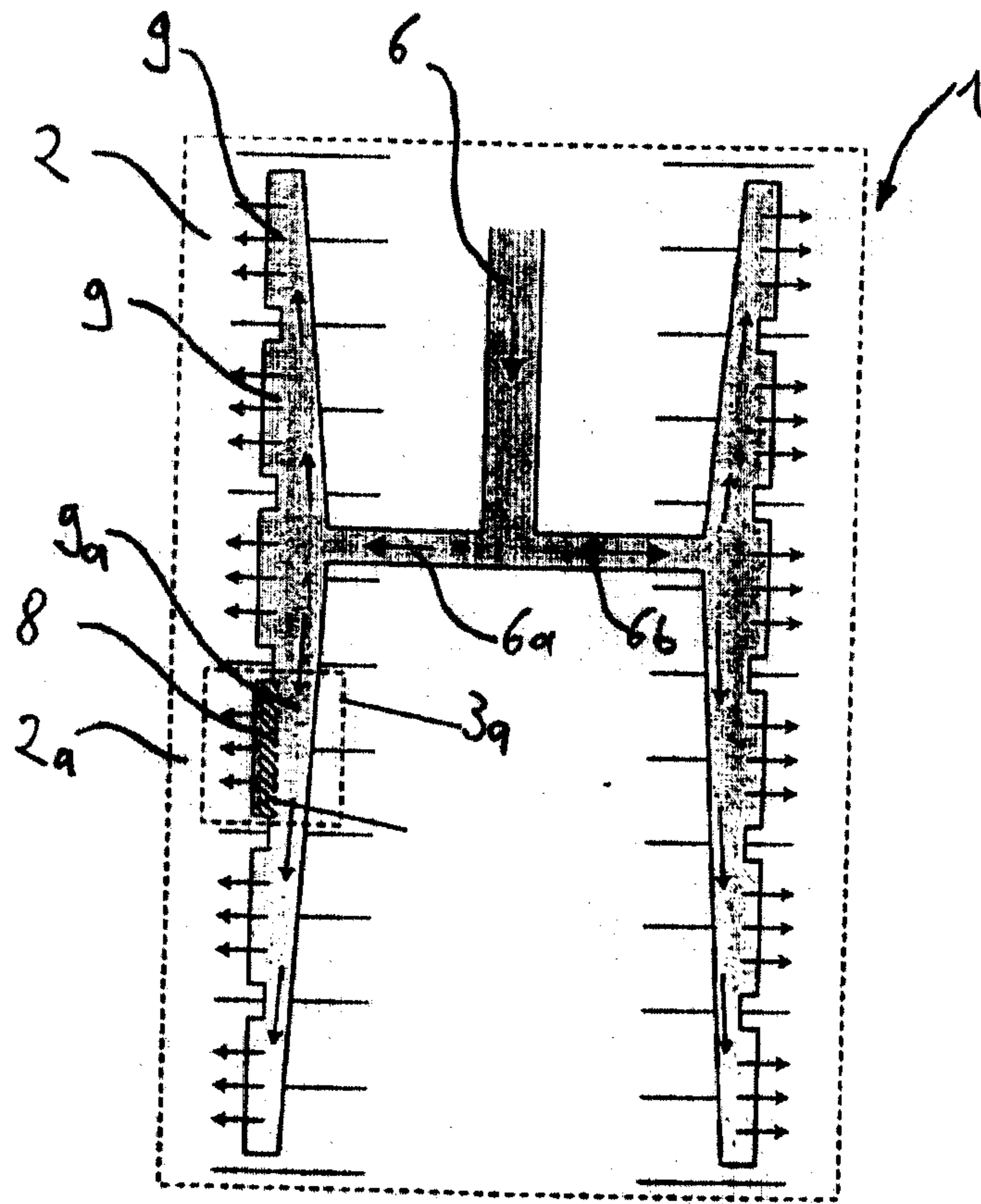

Fig. 3

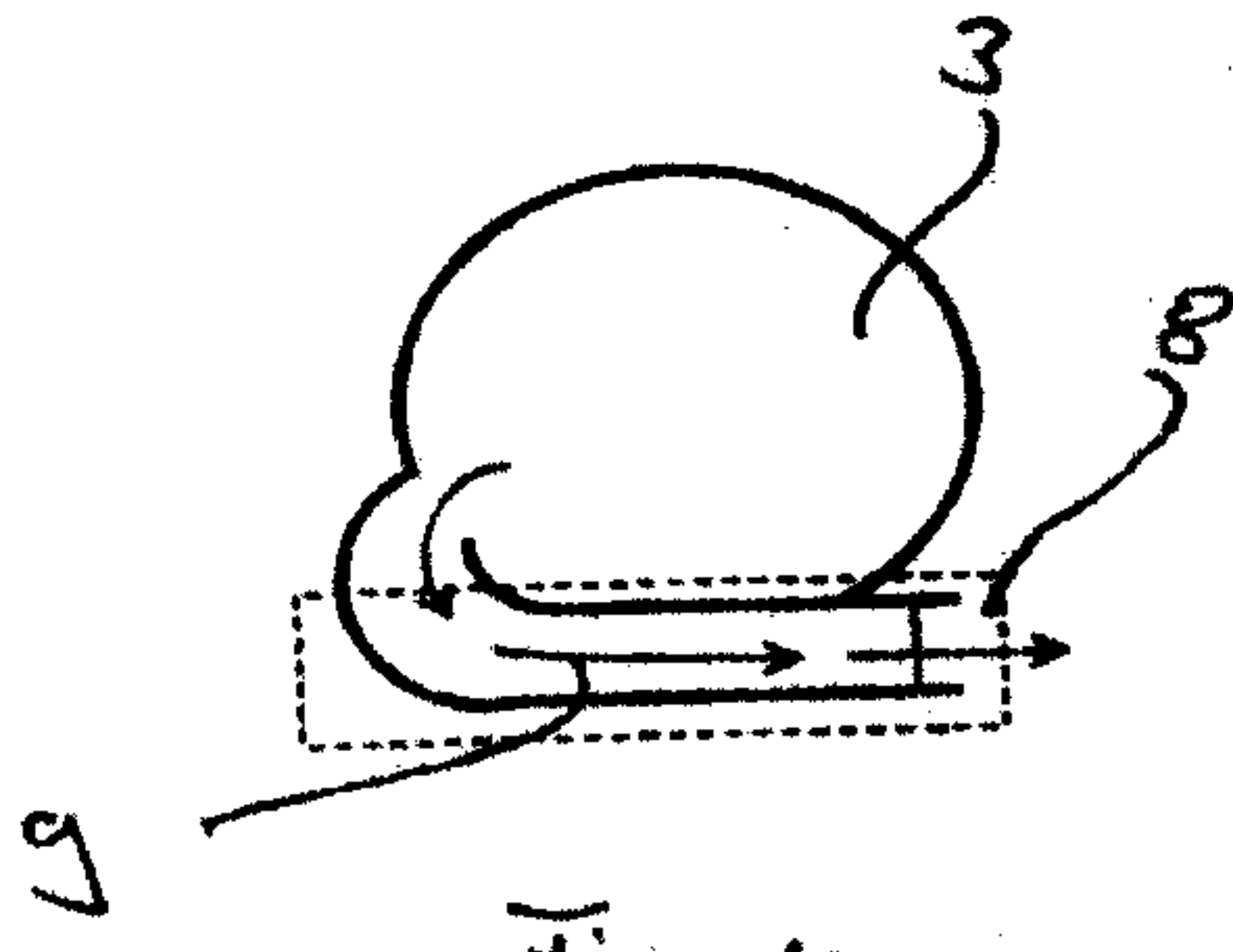

Fig. 4

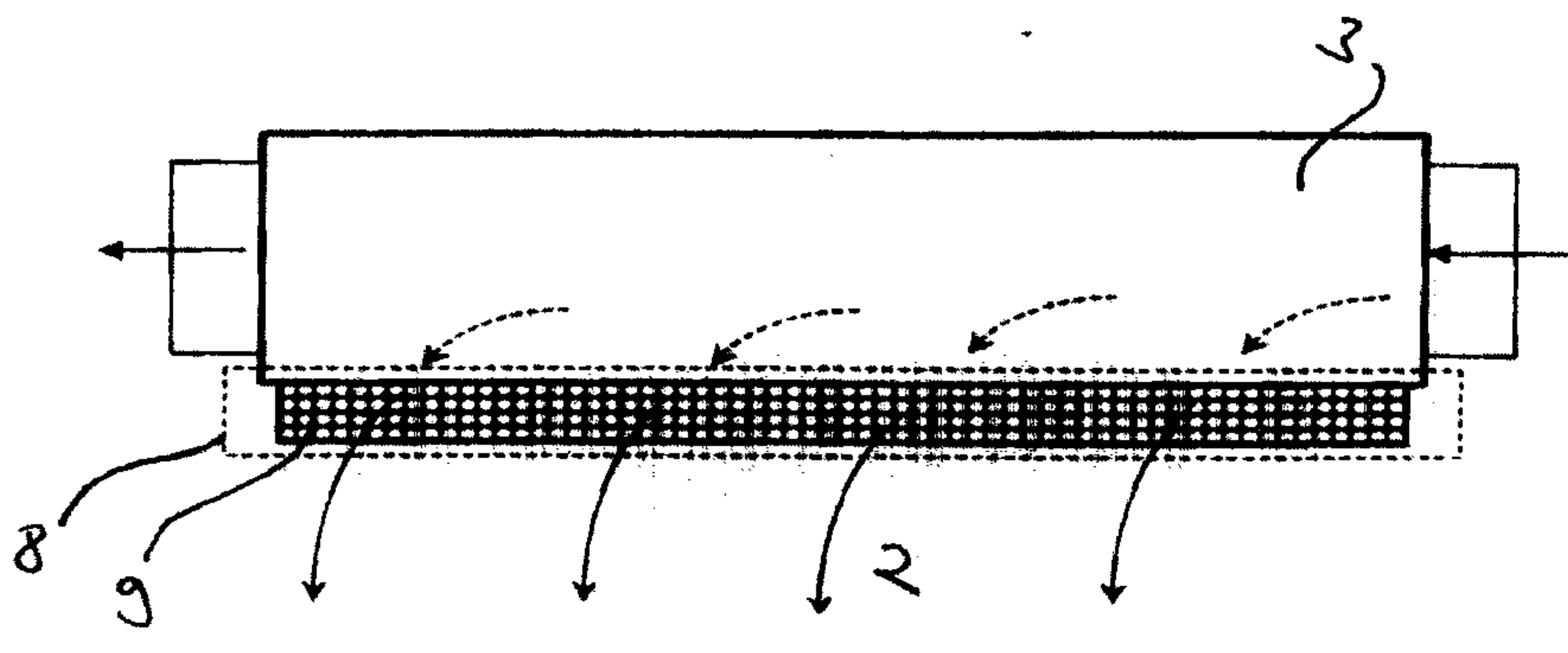

Fig. 5

