

*J. L. Gray,
Soldering Machine.*

No 63,504.

Patented Apr. 2, 1867.

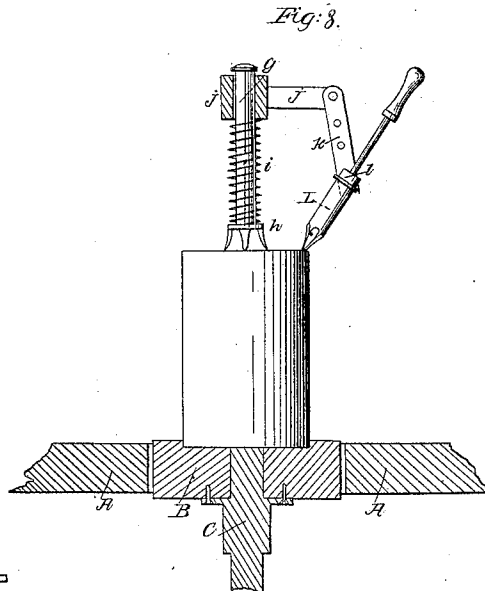
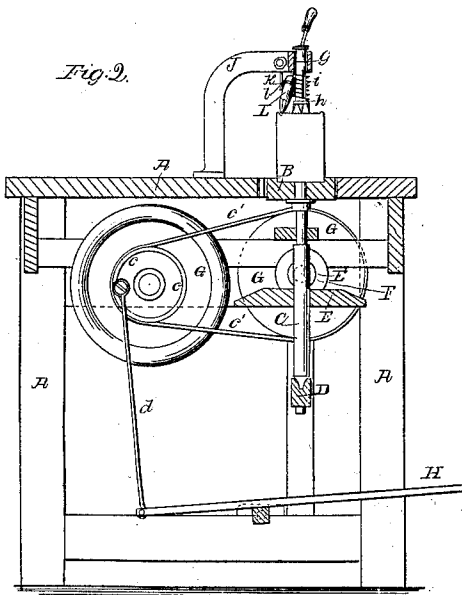
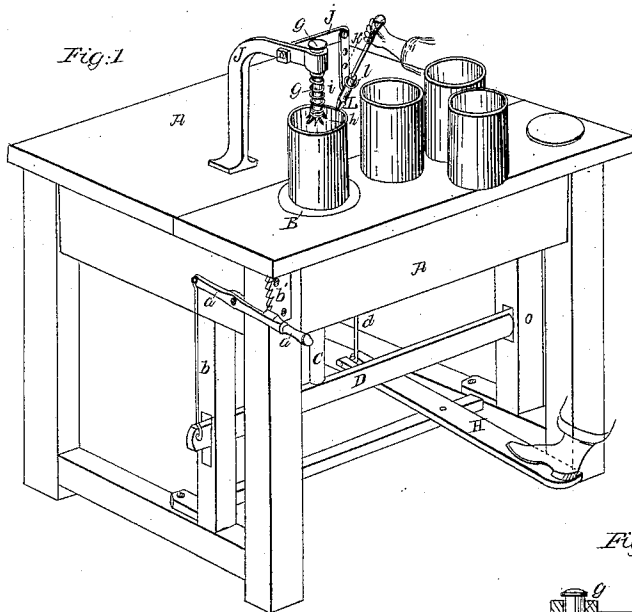

*Witnesses:
R. C. Campbell.
C. W. Schaefer.*

*Inventor:
J. L. Gray.
By
Mason, Junnck & Co.*

UNITED STATES PATENT OFFICE.

JAMES L. GRAY, OF BALTIMORE, MARYLAND, ASSIGNOR TO F. M. HAY,
M. L. GRAY, AND M. A. GRAY, OF SAME PLACE.

IMPROVED SOLDERING-MACHINE.

Specification forming part of Letters Patent No. 63,504, dated April 2, 1867.

To all whom it may concern:

Be it known that I, JAMES L. GRAY, of the city and county of Baltimore, State of Maryland, have invented a new and useful Machine for Soldering the Tops and Bottoms on Preserve-Cans; and I do hereby declare that the following is a full, clear, and exact description thereof, reference being had to the accompanying drawings, making a part of this specification, in which—

Figure 1 is a perspective view of the improved machine. Fig. 2 is a transverse section, taken in a vertical plane through the machine. Fig. 3 is an enlarged view, in detail, showing the devices for centering and holding a can in place during the operation of soldering its bottom or top.

Similar letters of reference indicate corresponding parts in the several figures.

This invention relates to a new and improved machine which is designed for centering, holding, and rotating preserve-cans which are made of metal, during the operation of soldering on the bottoms and caps or tops of the cans, as will be hereinafter described.

To enable others skilled in the art to understand my invention I will describe its construction and operation.

In the accompanying drawings, A represents a table which is adapted for sustaining the several parts which support, center, and rotate the cans during the operation of soldering. B represents a circular bed upon which the cans are supported and centered. This bed is constructed with a concentric depression in its upper face, and it is secured upon the upper end of a spindle, C, which receives a rotary motion and also a vertical motion. The lower end of the spindle is stepped upon a lever, D, which is pivoted at one end to the frame of table A, and connected at its other end to a hand-lever, *a*, by a rod, *b*, as shown in Fig. 1. This hand-lever is pivoted to one side of the table-frame in a convenient position to the operator standing at the machine, and it is held in the desired position by means of teeth upon a ratchet-plate, *b'*.

The operator can, by means of lever *a*, raise or depress the rotary bed B and its spindle, at pleasure.

The spindle C has a beveled friction-wheel, E, keyed upon it, which is acted upon by a friction-pinion, E', on a horizontal shaft, F. This shaft carries a belt-wheel, G, and is rotated by a balance-wheel, G', through the medium of a belt-collar, *c*, on this balance-wheel, and an endless belt, *c'*, as shown in Fig. 2. The balance-wheel is rotated by means of a treadle, H, to which it is connected by the pitman-rod *d*. On top of the table A a curved overhanging bracket, J, is secured, which receives, through a vertical eye formed on its end, a vertical rod, *g*. This rod coincides with the axis of motion of the bed B, and is allowed to receive a vertical movement in its eye-bearing. On the upper end of the rod *g* a head is formed for preventing it from slipping down out of its bearing, and on the lower end of this rod spurs are formed, as shown in the drawings. Between the spurred enlargement *h* and the eye-bearing on standard J, a spring is applied, as shown at *i*, for the purpose of holding the cans down in place with an elastic pressure. A bracket-arm, *j*, is secured to the right-hand side of the standard J, to the outer end of which an arm, *k*, is pivoted, having a ring-bearing, *l*, applied to it, for receiving and supporting a soldering-iron, L, as shown in the drawings.

Having thus described the several parts of the machine, I will now describe the operation thereof.

The furnace for heating the soldering-irons may be located upon the table A, or in any other convenient position to the operator. The rotary bed B is depressed by releasing the lever *a* from its ratchet-teeth. The heated soldering-iron is then inserted through its ring-bearing *l*, and the can placed upon the bed B and centered in the depression in this bed. The operator, with his foot upon the treadle H, rotates the driving-shaft, and at the same time elevates the bed B to the position shown in Figs. 2 and 3, which movement brings the friction-wheels E E' together, and also causes the spring-rod *g* to press upon the center of the loose plate upon the can. The plate which is to be soldered upon the can, and also the can itself, are, in this manner, held firmly in their places and caused to rotate. During

this rotation of the can the operator, with his hand upon the handle of the soldering-iron, solders the plate in place, after which the bed B is depressed and the can removed.

Having described my invention, what I claim as new, and desire to secure by Letters Patent, is—

1. A rotary bed, B, in combination with a yielding holder, *g*, or their equivalents, operating substantially as and for the purpose described.

2. The spurs *h*, in connection with the yielding holder *g*, substantially as and for the purpose described.

3. In combination with the rotary bed B and yielding holder *g*, the soldering-iron support, substantially as and for the purpose described.

4. The within-described machine for centering, supporting, and rotating preserve-cans, said machine having its parts constructed, arranged, and operated substantially as set forth.

JAMES L. GRAY.

Witnesses:

FRANCIS M. HAY,
R. T. CAMPBELL.