

(19) World Intellectual Property Organization  
International Bureau



(43) International Publication Date  
18 November 2004 (18.11.2004)

PCT

(10) International Publication Number  
WO 2004/099830 A1

(51) International Patent Classification<sup>7</sup>: G02B 3/14, 26/02

(21) International Application Number:  
PCT/IB2004/050563

(22) International Filing Date: 3 May 2004 (03.05.2004)

(25) Filing Language: English

(26) Publication Language: English

(30) Priority Data:  
03076376.7 6 May 2003 (06.05.2003) EP

(71) Applicant (for all designated States except US): KONINKLIJKE PHILIPS ELECTRONICS N.V. [NL/NL]; Groenewoudseweg 1, NL-5621 BA Eindhoven (NL).

(72) Inventors; and

(75) Inventors/Applicants (for US only): KUIPER, Stein [NL/NL]; c/o Prof. Holstlaan 6, NL-5656 AA Eindhoven (NL). HENDRIKS, Bernardus, H., W. [NL/NL]; c/o Prof. Holstlaan 6, NL-5656 AA Eindhoven (NL). RENDERS, Christina, A. [NL/NL]; c/o Prof. Holstlaan 6, NL-5656 AA Eindhoven (NL). HAYES, Robert, A. [AU/NL]; c/o Prof. Holstlaan 6, NL-5656 AA Eindhoven (NL).

(74) Agent: VISSER, Derk; Prof. Holstlaan 6, NL-5656 AA Eindhoven (NL).

(81) Designated States (unless otherwise indicated, for every kind of national protection available): AE, AG, AL, AM, AT, AU, AZ, BA, BB, BG, BR, BW, BY, BZ, CA, CH, CN, CO, CR, CU, CZ, DE, DK, DM, DZ, EC, EE, EG, ES, FI,

GB, GD, GE, GH, GM, HR, HU, ID, IL, IN, IS, JP, KE, KG, KP, KR, KZ, LC, LK, LR, LS, LT, LU, LV, MA, MD, MG, MK, MN, MW, MX, MZ, NA, NI, NO, NZ, OM, PG, PH, PL, PT, RO, RU, SC, SD, SE, SG, SK, SL, SY, TJ, TM, TN, TR, TT, TZ, UA, UG, US, UZ, VC, VN, YU, ZA, ZM, ZW.

(84) Designated States (unless otherwise indicated, for every kind of regional protection available): ARIPO (BW, GH, GM, KE, LS, MW, MZ, NA, SD, SL, SZ, TZ, UG, ZM, ZW), Eurasian (AM, AZ, BY, KG, KZ, MD, RU, TJ, TM), European (AT, BE, BG, CH, CY, CZ, DE, DK, EE, ES, FI, FR, GB, GR, HU, IE, IT, LU, MC, NL, PL, PT, RO, SE, SI, SK, TR), OAPI (BF, BJ, CF, CG, CI, CM, GA, GN, GQ, GW, ML, MR, NE, SN, TD, TG).

Declaration under Rule 4.17:

— as to applicant's entitlement to apply for and be granted a patent (Rule 4.17(ii)) for the following designations AE, AG, AL, AM, AT, AU, AZ, BA, BB, BG, BR, BW, BY, BZ, CA, CH, CN, CO, CR, CU, CZ, DE, DK, DM, DZ, EC, EE, EG, ES, FI, GB, GD, GE, GH, GM, HR, HU, ID, IL, IN, IS, JP, KE, KG, KP, KR, KZ, LC, LK, LR, LS, LT, LU, LV, MA, MD, MG, MK, MN, MW, MX, MZ, NA, NI, NO, NZ, OM, PG, PH, PL, PT, RO, RU, SC, SD, SE, SG, SK, SL, SY, TJ, TM, TN, TR, TT, TZ, UA, UG, UZ, VC, VN, YU, ZA, ZM, ZW, ARIPO patent (BW, GH, GM, KE, LS, MW, MZ, NA, SD, SL, SZ, TZ, UG, ZM, ZW), Eurasian patent (AM, AZ, BY, KG, KZ, MD, RU, TJ, TM), European patent (AT, BE, BG, CH, CY, CZ, DE, DK, EE, ES, FI, FR, GB, GR, HU, IE, IT, LU, MC, NL, PL, PT, RO, SE, SI, SK, TR), OAPI patent (BF, BJ, CF, CG, CI, CM, GA, GN, GQ, GW, ML, MR, NE, SN, TD, TG)

[Continued on next page]

(54) Title: ELECTROWETTING MODULE

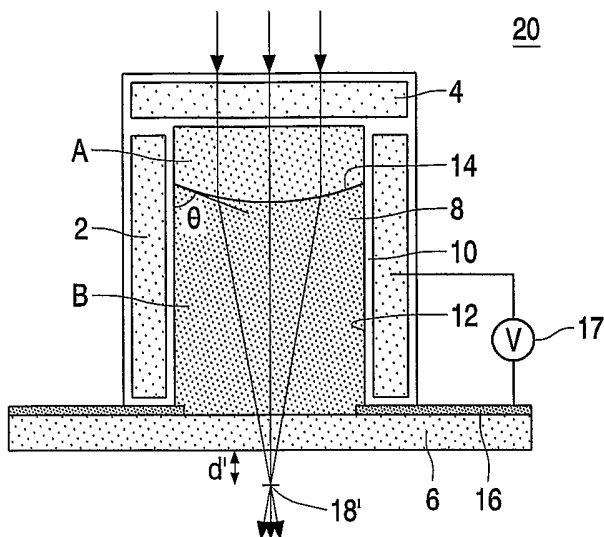

(57) Abstract: An electrowetting module (20) comprises a fluid chamber (8) which contains a first fluid (A) and a second fluid (B), which are separated by an interface (14), and means to (16, 17) exert a force on at least one of the fluids to change the position and/or shape of the interface. By providing at least one of the fluids with a compound having a zero dipole moment in the gaseous phase, the performance of the module can be enhanced. For example the optical power of an electrowetting lens (30) can be increased.

WO 2004/099830 A1



**Published:**

— *with international search report*

*For two-letter codes and other abbreviations, refer to the "Guidance Notes on Codes and Abbreviations" appearing at the beginning of each regular issue of the PCT Gazette.*

## Electrowetting module

The invention relates to an electrowetting module, comprising a cavity, containing at least a first body of a first fluid and a second body of a second fluid, the two bodies being separated by an interface, and means for exerting a force on at least one of the bodies to change the position and/or shape of the interface.

5 It is observed that wetting techniques make it possible to manipulate a volume of a fluid along a predetermined path. With these techniques, the surface tension of said volume is locally altered (usually reduces), causing the volume to flow in the direction of its lowest surface tension.

10 Further, it is observed that a fluid is a substance that alters its shape in response to any force, and includes gases, vapors, liquids and mixtures of solids and liquids, capable of flow.

The term "wettability" of a surface by a certain fluid gives an indication of the ease with which said fluid may wet said specific surface, which may for instance depend on the nature of and/or the electric potential across said surface. If a surface has a "high  
15 wettability" by a specific fluid, this indicates that a droplet of said fluid in contact with said surface will have a rather expanded shape, with a relatively large contact area and a relatively small contact angle, usually less than about 90°. "Low wettability" indicates that the droplet in contact with said surface will have a rather contracted shape, with a relatively small contact area and a relatively large contact angle, usually exceeding about 90°.

20 The term "wetting" is understood to encompass all techniques causing the surface tension of a volume, e.g. a droplet of a specific fluid to be locally varied, so as to influence the wetting behavior of said fluid with respect to a specific surface.

In modules wherein use is made of the wettability phenomenon, it is necessary that the two fluids have desired properties, for example: densities as close as possible; low  
25 melting points; adapted viscosity; good electrowetting behavior; non poisonous; and, in case of an optical module, transparency and indices of refraction of a certain predetermined difference.

An example of such an optical module is an electrowetting-based lens, also called an electrowetting lens, of which the focal distance can be changed. In an

electrowetting lens the interface between the two fluid bodies is a meniscus. In such a module the first fluid body is an electrically conducting and/or polar liquid and the second fluid body is an electrically non-conducting liquid. The first liquid is, for example salted water and the second liquid is, for example an organic non-polar, water-immiscible liquid such as decane and silicone oil. The electrowetting optical module is provided with means for exerting an electrical force by means of which the shape and or the position of the meniscus can be shaped. Other examples of the electrowetting optical module are zoom lenses, diaphragms, diffraction gratings, filters and beam deflectors. Embodiments of these modules are described in PCT patent application no. IB03/00222 and in European patent applications nos. 020789309.2, 02080387.0 and 02080060.3. The electrowetting optical modules are very compact and may therefore be used with much advantage in devices, like optical disc scanning devices, mini cameras for a/o mobile phones, displays etc.

The optical power of an optical electrowetting module is determined by the curvature of the meniscus and the difference between the refractive index of the first liquid and that of the second liquid. There is a growing demand for optical electrowetting modules, which can produce large optical power variations. Since the maximum change in curvature of the meniscus is determined by the size of the electrowetting cell, the change in optical power that can be realized by the change of the curvature is limited for a given electrowetting lens. The problem of increased power thus should be solved in another way.

Another electrowetting module is a motor which uses the electrowetting effect to manipulate a volume of fluid along a predetermined path, which fluid causes two motor elements to move relative to each other, as will be described later on. In such a motor one of the bodies of fluids may be flattened due to centrifugal forces, if the densities of the first fluid and of the second fluid are not matched to each other.

It is an object of the invention to provide an electrowetting module as defined in the opening paragraph, which module, if used as an optical module, allows varying the optical power over a larger range. The electrowetting module is characterized in that at least one of the fluids comprises a compound having a zero dipole moment in the gaseous phase. The dipole moment in the liquid phase is preferably also zero. The at least one of the fluids is preferably electrically non-conducting.

This electrowetting module is based on the insight that it appeared to be possible to increase the refractive index and/or the density of a fluid suitable for electrowetting by using compounds which are substituted with atoms or groups which have a high atomic or molecular mass. Such atoms or groups often turn the non-polar molecules of

the original fluid into polar molecules, due to differences in electro negativity. The symmetrical substitution of these atoms or groups removes the influence of electronegativity, so that thus substituted compounds can be used for electrowetting purposes.

In this way the optical power and the range of power variation can be increased. If the said compound is used as or included in the non-polar fluid in an electrowetting motor, it prevents flattening of the fluid.

In a special embodiment of the module the at least one of the fluids comprises at least one of an alkane, a siloxane and a germoxane. These solvents have a low dipole moment. When a compound having zero dipole moment is dissolved in such a solvent, a fluid suitable for electrowetting is obtained.

In another special embodiment the at least one of the fluids essentially comprises molecules having zero dipole moment.

The compound having a zero dipole moment preferably contains symmetric molecules.

Another aspect of the invention is that for an optical module the curvature of the meniscus can be decreased while maintaining the optical power. In this way the sensitivity for optical aberrations of the module can be reduced. Moreover the actuating voltage needed for a required change in the optical power can be reduced.

It is remarked that an electrowetting lens with fluid bodies showing an increased refractive index difference is disclosed, for example by B. Berge and J. Peseux in Eur. Phys. J. E3, 159-163 (2000). The fluid bodies of this lens consist of water and chloronaphthalene respectively. This lens, however does not show good electrowetting behavior, especially not for DC voltages. It is now assumed that this is due to the fact that chloronaphthalene is an asymmetric molecule, having a certain dipole moment, which will influence the electrowetting behavior negatively.

A group of compounds has been traced, which provide fluids or liquids with refractive indices and/or densities which are larger than known fluids and thus are very suitable to be used as or to be included in at least one of the fluids of the electrowetting module of the invention. Preferred compounds are defined in claims 2 to 7.

A module comprising such a compound may be configured as an optical component, the first and said second fluid body having different refractive indices. In such an optical module the compound added to one of the fluids has a refractive index difference increasing effect.

In such a module the first fluid body may be electrically conducting and/or polar, and the second fluid body may be electrically non-conducting and the module may be provided with means for exerting an electric force to change the position and/or shape of the meniscus-shaped interface.

5                   The difference in refractive index is from 0.05 to 0.3, preferably from 0.1 to 0.2; the refractive index of said second, non-conducting body being larger than 1.4, preferably larger than 1.5, more preferably larger than 1.55. Typically, the second body has a low refractive index between 1.3 and 1.5, more specifically between 1.33 and 1.43.

10                   Preferably the first and second fluid bodies show a substantially similar density.

15                   These and other aspects of the invention will be apparent from and elucidated by way of non-limitative example with reference to the embodiments described hereinafter and illustrated in the accompanying drawings.

In the drawings:

Fig. 1 shows, in a cross-section through its optical axis, a known electrowetting lens in a non-activated state;

Fig. 2 shows such a lens in an activated state;

20                   Fig. 3 shows a lens according to the invention in an activated state, and

Figs 4a and 4b shows, in a cross-sectional view, an activated electrowetting motor at two different moments in time.

25                   Fig. 1 shows an electrowetting module constituting a variable focus lens. The element comprises a first cylindrical electrode 2 forming a capillary tube, sealed by means of a transparent front element 4 and a transparent rear element 6 to form a fluid chamber 8 containing two fluids. The electrode 2 may be a conducting coating applied on the inner walls of a tube.

30                   In this embodiment of the electrowetting module the two fluids consist of two non-miscible liquids in the form of an electrically insulating first liquid A, currently, for example a silicone oil or an alkane, and an electrically conducting second liquid B, currently, for example, water containing a salt solution. The first fluid A has a higher refractive index than the second fluid B.

The first electrode 2 is a cylinder of inner radius typically between 1mm and 20mm. This electrode is formed of a metallic material and is coated by an insulating layer 10, formed for example of parylene. The insulating layer has a thickness of between 50 nm and 100  $\mu\text{m}$ . The insulating layer is coated with a fluid contact layer 12, which reduces the  
5 hysteresis in the contact angle of the meniscus 14, i.e. the interface between the fluids A and B, with the cylindrical wall of the fluid chamber. The fluid contact layer is preferably formed from an amorphous fluorocarbon such as Teflon<sup>TM</sup> AF1600 produced by DuPont<sup>TM</sup>. The fluid contact layer 12 has a thickness between 5nm and 50  $\mu\text{m}$ .

A second, annular, electrode 16 is arranged at one side of the fluid chamber, in  
10 this case, adjacent the rear element 6. The second electrode is arranged with at least one part in the fluid chamber such that the electrode acts on the second fluid B.

The two fluids A and B are non-miscible so as to tend to separate into two fluid bodies separated by a meniscus 14. When no voltage is applied between the first and second electrodes, the fluid contact layer 12 has a higher wettability with respect to the first  
15 fluid A than with respect to the second fluid B. Fig.1 shows this lens configuration, i.e. the non-activated state of the electrowetting lens. In this configuration, the initial contact angle  $\theta$  between the meniscus and the fluid contact layer 12, measured in the fluid B, is larger than  $90^\circ$ . Since the refractive index of the first fluid A is larger than the refractive index of the second fluid B, the lens formed by the meniscus, here called meniscus lens, has a negative  
20 power in this configuration.

Due to electrowetting, the wettability by the second fluid B varies under the application of a voltage between the first electrode and the second electrode, which tends to change the contact angle. Fig. 2 shows the lens configuration if such a voltage from a source  
17 is supplied to the lens, i.e. if the lens is in the activated state. In this case the voltage is  
25 relatively high, for example between 150V and 250V and the meniscus has now a convex shape. The maximum contact angle  $\theta$  between the meniscus and the fluid contact layer 12 is, for example of the order of  $60^\circ$ . Since the refractive index of fluid A is larger than fluid B, the meniscus lens 1 in this configuration has a positive power and it focuses an incident beam  
b in a focal spot 18 at a certain distance d from the lens.

30 For further details about the construction of the variable focus lens reference is made to international patent application no. IB03/00222. A zoom lens, which comprises at least two independently controllable interfaces between a higher refractive index liquid and lower refractive index fluid, is described in the European patent application no. 02079473.1 (PHNL021095).

In an electrowetting lens the optical power of the lens depends on the curvature of the meniscus and the difference in refractive indices between the conductive and non-conductive liquids, as can be seen in the following equation:

$$S = \frac{n_1 - n_2}{r}$$

5           Wherein S is the optical power of the meniscus lens, r the radius of curvature of the meniscus,  $n_2$  the refractive index of the non-conductive liquid A and  $n_1$  the refractive index of the conductive liquid B.

In practice there is a need to increase the range in which the power of a variable focus lens can be varied. For example, for a zoom lens based on electrowetting the maximum attainable zoom factor is strongly related to the maximum attainable change in optical power of individual electrowetting lenses of such a zoom lens.

From the above equation follows that the optical power change of an electrowetting lens depends on the difference in refractive indices between the conducting and non-conductive liquids and on the change in curvature of the meniscus. Since the maximum change in curvature is determined by the size of the electrowetting cell, the change in optical power caused by change in curvature is limited for a given electrowetting lens. Moreover a strong curvature of the meniscus introduces optical aberrations in the beam passing the electrowetting lens and requires a high control voltage. A larger optical power change can be achieved by enlarging the difference in refractive index between the conductive liquid and the non-conductive liquid. The non-conductive liquids currently used in electrowetting lenses (e.g. alkanes or silicone oils) have a refractive index ( $n = 1.37-1.43$ ) that is only slightly larger than the refractive index of the currently used conductive liquids (e.g. water,  $n = 1.33$ ). Typically the difference in refractive index is below 0.1.

According to the present invention at least one compound, which has a zero dipole moment in the gaseous phase is used as the non-conducting, or non-polar, liquid or solution A, or as a component in this liquid or solution. When a compound is used which is substituted with atoms or groups having a higher molecular weight, an additional effect can be obtained in that its presence might increase the refractive index in the liquid A substantially, whilst the other requirements for the liquid, such as high transparency, non-miscibility with the other liquid or fluid B and a good electrowetting behavior still can be satisfied.

This measure can be used to increase the range of power variations of a variable focus electrowetting lens having a given meniscus curvature or to reduce meniscus



curvature of a variable focus lens having a given range of power variations. If used in an electrowetting zoom lens, the measure allows increasing the zoom factor. By not-increasing or decreasing the meniscus curvature the sensitivity for optical aberrations in the optical system of which the electrowetting lens forms is not increased or decreased, respectively.

5 Moreover, the required actuation voltage to achieve a certain change in optical power is lower.

Fig. 3 shows an electrowetting lens 20, which has the same construction and configuration as the lens of Fig.2, but is provided with a non-conducting fluid A' that comprises the said compound having a zero dipole moment in the gaseous phase, instead of  
10 the fluid A of Fig. 2. The result of the replacement of fluid A by fluid A' supplying to the lens 20 a control voltage that has the same level as the voltage supplied to the lens 1 of Fig. 2 is in the same and maintaining the level is that the focal spot 18' is situated at a distance d' from the lens, which is smaller than the distance d in Fig. 2.

For electrowetting lenses in general it is important that the meniscus shape is  
15 independent of orientation and thus of gravity. The shape will be perfectly spherical and independent of orientation if the densities of the liquids are equal. This requirement can also be satisfied in the electrowetting lens according to the invention.

A number of compounds have been traced which, if used in or as a component of the non-conducting fluid in an electrowetting lens, provide the required properties: high  
20 refractive index, transparent, non-miscible with the conducting fluid, a density substantially similar to that of the conductive fluid (i.e. a small difference between the densities is allowed), proper melting and boiling points and a good electrowetting behavior. Examples of non-conductive liquids or soluble solids having a zero dipole moment, which are very suitable to be used with the invention are given in Table 1:

25

Table 1

Material	State (20°C)	Density (g/cm <sup>3</sup> )	Refractive Index	Solvents *1	Use Effects
Carbondisulfide	liquid	1.26	1.63		*2, *3
Carbondiselenide	liquid	2.68	1.85		*2, *3
Carbontetrachloride	liquid	1.59	1.46		*2

Carbontetrabromide	solid	2.96	1.59	-alkanes -silicone oil -mesitylene -carbontetra- chloride	* <sup>2</sup> , * <sup>3</sup>
Tetrachloroethylene	liquid	1.62	1.51		* <sup>2</sup> , * <sup>3</sup>
Benzene	liquid	0.87	1.50		* <sup>3</sup>
Naphthalene	solid	1.03	1.59	-carbondi- sulfide -carbontetra- chloride -alkanes	* <sup>3</sup>
p-Xylene	liquid	0.86	1.50		* <sup>3</sup>
Mesitylene	liquid	0.87	1.50		* <sup>3</sup>
1,4-Dichlorobenzene	solid	1.25	1.53	-alkanes -carbondi- sulfide	* <sup>2</sup> , * <sup>3</sup>
1,4-Dibromobenzene	solid	1.83	1.57	-mesitylene -carbontetra- chloride	* <sup>2</sup> , * <sup>3</sup>
Tetramethyltin	liquid	1.29	1.44		* <sup>2</sup>
Reference: Octamethyltrisiloxane	liquid	0.82	1.38		

\*<sup>1</sup> Examples of preferred solvents to be used as the non-conducting solvent in combination with the indicated material.

\*<sup>2</sup> Density matching.

5 \*<sup>3</sup> Increase of refractive index.

10 From Table 1 it follows that the selected compounds with zero dipole moments have refractive indices typically larger than 1.46, making them suitable for electrowetting lenses with large optical power range. Preferably, the subset with a refractive index greater than 1.5 is particularly suited because they allow miniaturized zoom lenses for portable applications (for instance mobile phone) with a larger zoom factor. Even more preferred are the class of symmetric liquids or solutions with a benzene ring as the central molecule, thus symmetric, substituted benzene compounds, such as p-xylene, mesitylene and 1,4-dichlorobenzene.

It is in this respect observed that it is known to increase the density of the second fluid by using modified molecules, the modification consisting of halogenation, for example. Reference being made to decane, having a density of  $0.73 \text{ g/cm}^3$ , while 1-bromodecane has a density of  $1.07 \text{ g/cm}^3$ , and to naphthalene, having a density of  $1.03 \text{ g/cm}^3$ , while chloronaphthalene has a density of  $1.63 \text{ g/cm}^3$ .

These modified materials appeared to give bad results, especially under DC voltage operation. It has now been found that this is due to an increased dipole moment of the molecules, which dipoles interact with the applied field and disturb the electrowetting effect.

The present compounds thus also comprise compounds having a central benzene ring. The benzene ring results in a high refractive index, compared with a corresponding aliphatic chain. Modification by halogenation of such compounds revealed that the compounds having an aliphatic chain had bad electrowetting properties due to the relatively large dipole moment.

The invention may also be used in an electrowetting motor wherein use is made of the fact that the shape of the interface can be changed by means of an electric force, on the basis of the wetting technique, for manipulating a volume of a fluid along a predetermined path. Figs. 4A and 4B show a cross-sectional view of an embodiment of such a motor 30, in particular a rotary motor, at different time moments. The motor comprises a substantially cylindrical first body 33 and a substantially cylindrical second body 35, which is concentrically positioned within the first body 33. The first and second body 33, 35 enclose between their respective inner and outer surface a substantially cylindrical chamber 34, which is filled with a non-polar and/or non-conductive first fluid 36, such as an oil, and volumes 37a-d of a polar and/or conductive second fluid 37, in this example an aqueous solution, for instance (salted) water. The fluids 36, 37 are immiscible.

The first body 33 is provided with means for varying the wettability of its inner surface, namely twelve electrodes 40 extending in axial direction of the first body 33, spaced at substantially regular radial intervals along the circumference. The inner surface of the first body 33 is covered with a layer 42 of electrically insulating, hydrophobic material or more generally, a material having a wettability by the second fluid 37 which is lower than the wettability by the first fluid 36. Examples of such material are for instance Teflon-like materials like the amorphous fluoropolymer AF1600 provided by Dupont or parylene or a combination thereof, in case where the first fluid 36 is an oil or air and the second fluid is (salted) water. The electrodes 40 are connected to a voltage supply (not shown).

The second body 35 is of solid design but could be hollow, if so desired, and is mounted movably, in particular rotatably, in the first body 33 by one or more suitable bearings. The or each bearing could for instance be an oil bearing, configured by providing the first and/or second body 33, 35 with an annular groove, in which upon rotation of the second body 35, pressure will build up, centering the second body 35 in the first body 33. The second body 35 is provided at its outer surface with coupling means in the form of four hydrophilic areas 44, said number corresponding to the number of volumes 37a-d. These areas 44 could for instance be made of or covered by a material having a wettability by the second fluid 37 that is higher than the wettability by the first fluid 36, which material could for instance be glass. The areas 44 are separated from each other in radial direction by areas 45, made of or covered by hydrophobic material, which could be a selection from any of the materials mentioned before. Additionally or alternatively, the hydrophilic areas 44 may be recessed to enhance the coupling force with the volumes. Furthermore, two or more of the volumes 37a-d could be interconnected via at least one suitable conduit 39 in second body 35, as illustrated in broken lines in Figs. 4A and 4B. The areas of high and low wettability 44, 45 may be omitted, but can also be maintained, to increase the maximum force of the motor may exert.

A motor as described above operates as follows. In Fig. 4A the electrodes 40 marked with Roman numerals I (that is the upper, lower, left and right electrodes) are supplied with a voltage. Consequently, the hydrophobic layer 42 covering said electrodes I will become locally hydrophilic. The four volumes 37a-d will therefore contact the first body 33 at the four electrodes I. They furthermore contact the second body 35 at the coupling means, that is the hydrophilic areas 44 and the conduits 39. If subsequently the voltage supply is shifted to second electrodes II, situated next to the former electrodes I, the layer above said second electrodes II will become hydrophilic, whereas the layer above the first electrodes I will switch back to hydrophobic. This gives rise to electrowetting forces which draw the volumes 37a-d towards the hydrophilic areas II as shown in fig. 4B. During this movement the volumes 37a-d will move along the hydrophilic area 44 of the second body 35 up to the edge of the hydrophobic area 45. Further movement along the second body 35 will be blocked by the combined action of the hydrophobic area 45 and the first fluid 36, enabling the volumes 37a-d to exert a wetting force on the second body 35, which will cause the body 35 to rotate. Hence by sequentially activating successive electrodes 40 I, II with a suitable voltage, the second body 35 can be rotated continuously. Preferably, the electrodes 40 are positioned relatively close to each other or even overlap through a "tooth" structure. Also, the

radial dimensions of the electrodes 40 are preferably equal to or smaller than the radial dimensions of the volumes 37a-d. Such positioning and/or dimensioning of the electrodes 40 will ensure that the volumes 37a-d can "sense" a newly supplied voltage to a succeeding electrode 40 II.

5                   In the given example the rotation is clockwise. It will be appreciated that this direction can be readily reversed by reversing the order in which the electrodes 10 I, II are activated. Obviously, the frequency of rotation will depend on the activation frequency of successive electrodes 40 I, II. It is noted that although in the illustrated example four volumes 37a-d of conductive fluid are used, any number of volumes can be used. The volumes 37a-d  
10 may be line-shaped in axial direction or consist of a series of axially spaced droplets. It is further noted that with the embodiment of Figs. 4A and 4B, it is also possible to have the first body 33 rotate instead of the second body 35, provided that the first body 33 is rotatable mounted and the second body 35 is fixed. In that case, upon switching the voltage from the first I to the second electrodes II, the volumes 37a-d would move towards the second  
15 electrodes II (featuring the higher wettability) up till the edge of the hydrophilic area 44. Subsequently, the second electrodes II due to wetting forces would be drawn to the volumes 37a-d, causing the first body 33 to rotate anti-clockwise. From this discussion it is also immediately clear that for the operation of the motor 30 it is irrelevant whether the electrodes 40 are positioned on the static body or the movable body. Therefore, although in practice the  
20 electrodes 40 will usually be placed on the static body to avoid wiring problems, the presented embodiment should in no way be seen as limiting.

The motor described may suffer from flattening of one of the bodies of fluids due to the exerted centrifugal force of the motor, which will influence its performance. According to the invention this can be prevented by using one of the compounds described  
25 above, for example one of the compounds of table 1. This table gives also the densities of the compounds.

The present compounds are preferably used as, or in, the non-conducting or non-polar liquid or fluid. Because most of the compounds have a density larger than water (which is usually the conducting liquid), it will be obvious that said compounds should be  
30 mixed with a compound having lower density, to match with the density of water.

Although the description has been limited to an electrowetting lens and an electrowetting motor as examples of an electrowetting module, the invention is not in any way limited to such modules. The invention may be used in any electrowetting module, such as a variable-focus lens, a zoom lens, a diaphragm, a filter and a beam deflector.

## CLAIMS:

1. An electrowetting module comprising a cavity, containing at least a first body of a first fluid and a second body of a second fluid, the two bodies being separated by an interface, and means for exerting a force on at least one of the bodies to change the position and/or shape of the interface, characterized in that at least one of the fluids comprises a  
5 compound having a zero dipole moment in the gaseous phase.
2. A module as claimed in claim 1, wherein the at least one of the fluids comprises at least one of an alkane, a siloxane and a germoxane.
- 10 3. A module as claimed in claim 1, wherein the at least one of the fluids essentially comprises molecules having zero dipole moment.
4. A module as claimed in claim 1, wherein the compound having a zero dipole moment contains symmetric molecules.  
15
5. A module as claimed in claim 1, wherein the compound having a zero dipole moment is at least one of an organic compound, an organometallic compound, a germanium-based compound and a silicon-based compound, being symmetrically substituted or not.
- 20 6. A module as claimed in claim 5, wherein the symmetric, organic compound contains 1 or 2 carbon atoms and is preferably selected from the group consisting of  $\text{CS}_2$ ,  $\text{CSe}_2$ ,  $\text{CCl}_4$ ,  $\text{CBr}_4$  and  $\text{C}(\text{Cl})_2 = \text{C}(\text{Cl})_2$ ,  $\text{C}(\text{Br})_2 = \text{C}(\text{Br})_2$ , more preferably  $\text{CCl}_4$  and  $\text{CBr}_4$ .
- 25 7. A module as claimed in claim 5, wherein the symmetric organic compound is an aromatic compound, being fused or not, and being substituted or not with at least two equal, electronegative residues.

8. A module as claimed in claim 7, wherein said aromatic compound is substituted with residues, selected from a C<sub>1</sub>-C<sub>5</sub> alkyl, or a halide residue, preferably methyl, chloride or bromide.
- 5 9. A module as claimed in claims 7 or 8, wherein said aromatic compound is selected from the group consisting of benzene, naphthalene, p-xylene, mesitylene, durene, mellitene, p-terphenyl, biphenyl, 1,4-dichlorobenzene and 1,4-dibromobenzene, 1,3,5-trichlorobenzene, 1,3,5-tribromobenzene, 1,2,4,5-tetrachlorobenzene, 1,2,4,5-tetrabromobenzene, hexachlorobenzene, hexabromobenzene, preferably p-xylene, mesitylene  
10 and 1,3,5-trichlorobenzene.
10. A module as claimed in claim 5, wherein said organometallic compound is a stannic compound, preferably tetramethyl tin.
- 15 11. A module as claimed in any one of claims 1 to 10, configured as an optical component, the first and said second fluid body having different refractive indices, wherein the compound added to one of the fluids has a refractive index difference increasing effect.
12. A module as claimed in claim 8, wherein the first fluid body is electrically  
20 conducting and/or polar, and the second fluid body is electrically non-conducting, the module being provided with means for exerting an electric force to change the position and/or shape of the meniscus-shaped interface.
13. A module as claimed in claim 11, wherein the difference in refractive index is  
25 from 0.05 to 0.3, preferably from 0.1 to 0.2; the refractive index of said second, non-conducting body, which comprises a compound having zero dipole moment in the gaseous phase, being larger than 1.4, preferably larger than 1.45, more preferably larger than 1.50, most preferably larger than 1.55.
- 30 14. A module as claimed in claim 11, wherein said first and said second fluid bodies show a substantially similar density.

15. A module as claimed in claim 14, wherein the second fluid body comprises a component having zero dipole moment in the gaseous phase and a density larger than  $1.0 \text{ g/cm}^3$ , preferably larger than  $1.05 \text{ g/cm}^3$ , specifically larger than  $1.50 \text{ g/cm}^3$ .



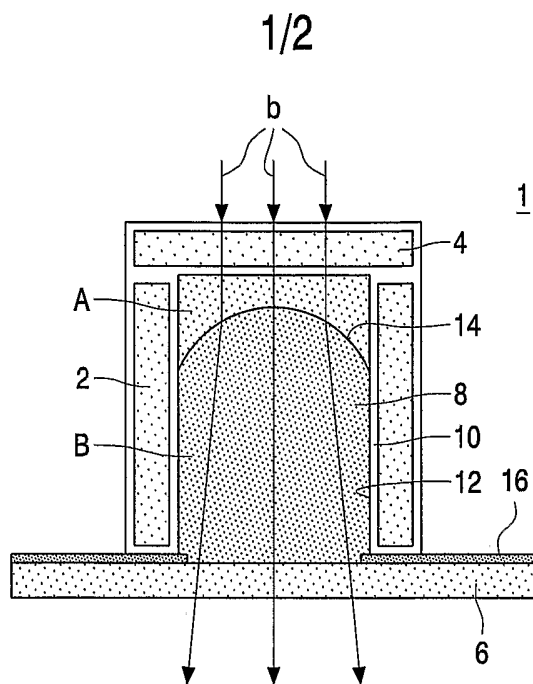

FIG. 1

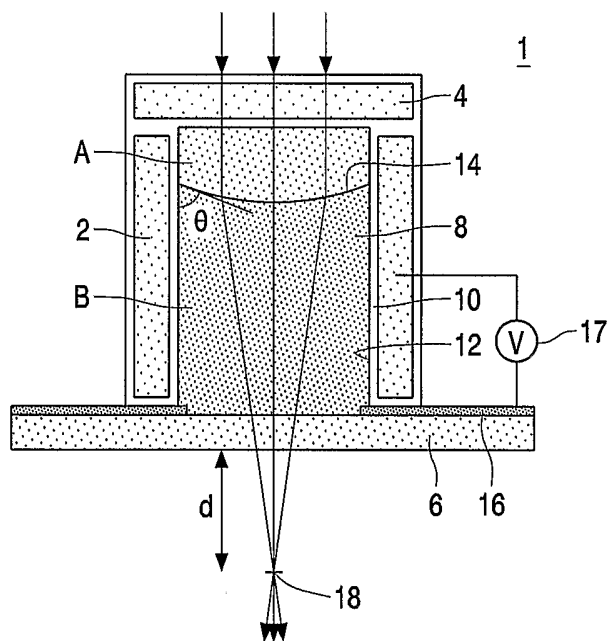

FIG. 2

2/2

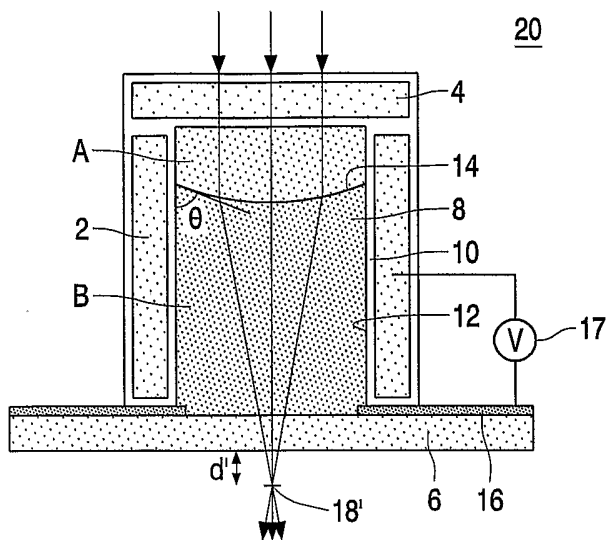

FIG. 3

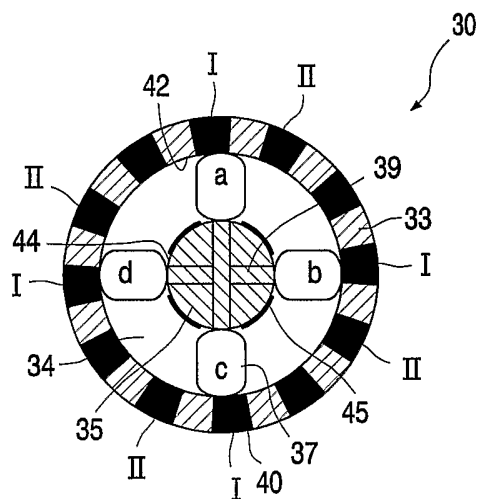

FIG. 4a

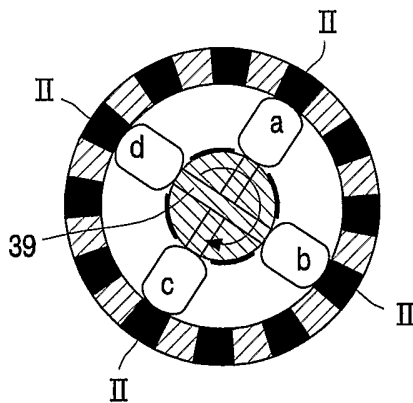

FIG. 4b

**INTERNATIONAL SEARCH REPORT**

International Application No  
IB2004/050563

**A. CLASSIFICATION OF SUBJECT MATTER**  
IPC 7 G02B3/14 G02B26/02

According to International Patent Classification (IPC) or to both national classification and IPC

**B. FIELDS SEARCHED**

Minimum documentation searched (classification system followed by classification symbols)  
IPC 7 G02B

Documentation searched other than minimum documentation to the extent that such documents are included in the fields searched

Electronic data base consulted during the international search (name of data base and, where practical, search terms used)

EPO-Internal, WPI Data, PAJ

**C. DOCUMENTS CONSIDERED TO BE RELEVANT**

Category °	Citation of document, with indication, where appropriate, of the relevant passages	Relevant to claim No.
X A	US 6 369 954 B1 (BERGE BRUNO ET AL) 9 April 2002 (2002-04-09)  column 1, line 38 - line 67 column 3, line 3 - line 39 column 6, line 48 - column 7, line 11; figures 1,6	1-5, 11-15 6-10
X	WO 02/099527 A (PRINS MENNO W J ; CORNELISSEN HUGO J (NL); KONINKL PHILIPS ELECTRONICS) 12 December 2002 (2002-12-12) page 2, line 29 - page 3, line 29; figures 1,2	1-5, 11-15

Further documents are listed in the continuation of box C.

Patent family members are listed in annex.

° Special categories of cited documents :

- \*A\* document defining the general state of the art which is not considered to be of particular relevance
- \*E\* earlier document but published on or after the international filing date
- \*L\* document which may throw doubts on priority claim(s) or which is cited to establish the publication date of another citation or other special reason (as specified)
- \*O\* document referring to an oral disclosure, use, exhibition or other means
- \*P\* document published prior to the international filing date but later than the priority date claimed

- \*T\* later document published after the international filing date or priority date and not in conflict with the application but cited to understand the principle or theory underlying the invention
- \*X\* document of particular relevance; the claimed invention cannot be considered novel or cannot be considered to involve an inventive step when the document is taken alone
- \*Y\* document of particular relevance; the claimed invention cannot be considered to involve an inventive step when the document is combined with one or more other such documents, such combination being obvious to a person skilled in the art.
- \* & \* document member of the same patent family

Date of the actual completion of the international search

25 August 2004

Date of mailing of the international search report

02/09/2004

Name and mailing address of the ISA  
European Patent Office, P.B. 5818 Patentlaan 2  
NL - 2280 HV Rijswijk  
Tel. (+31-70) 340-2040, Tx. 31 651 epo nl,  
Fax: (+31-70) 340-3016

Authorized officer

THEOPISTOU, P

## INTERNATIONAL SEARCH REPORT

International Application No

[B2004/050563

C.(Continuation) DOCUMENTS CONSIDERED TO BE RELEVANT		
Category °	Citation of document, with indication, where appropriate, of the relevant passages	Relevant to claim No.
X	<p>EP 1 069 450 A (CANON KK)            17 January 2001 (2001-01-17)            paragraph '0020! - paragraph '0025!            paragraph '0206!            paragraph '0212!            paragraph '0225!</p> <p style="text-align: center;">-----</p>	<p>1-5,            11-15</p>
X	<p>BERGE B ET AL: "Variable focal lens            controlled by an external voltage: an            application of electrowetting"            EUROPEAN PHYSICAL JOURNAL E. SOFT MATTER,            EDP SCIENCES, IT,            vol. 3, no. 2, October 2000 (2000-10),            pages 159-163, XP002285977            ISSN: 1292-8941            cited in the application            page 160, right-hand column, paragraph 2</p> <p style="text-align: center;">-----</p>	<p>1-5,            11-15</p>
P	<p>WO 03/069380 A (SNOEREN RUDOLPH M ; KUIPER            STEIN (NL); FEENSTRA BOKKE J (NL);            HENDRIKS) 21 August 2003 (2003-08-21)            cited in the application            page 3, line 31 - page 6, line 16</p> <p style="text-align: center;">-----</p>	<p>1-5,            11-14</p>

## INTERNATIONAL SEARCH REPORT

Information on patent family members

International Application No

IB2004/050563

Patent document cited in search report		Publication date	Patent family member(s)	Publication date
US 6369954	B1	09-04-2002	FR 2769375 A1	09-04-1999
			AT 214164 T	15-03-2002
			CA 2306249 A1	15-04-1999
			DE 69804119 D1	11-04-2002
			DE 69804119 T2	28-11-2002
			EP 1019758 A1	19-07-2000
			ES 2171041 T3	16-08-2002
			WO 9918456 A1	15-04-1999
			JP 2001519539 T	23-10-2001
WO 02099527	A	12-12-2002	EP 1402314 A1	31-03-2004
			WO 02099527 A1	12-12-2002
			JP 2004521389 T	15-07-2004
EP 1069450	A	17-01-2001	JP 2000356751 A	26-12-2000
			JP 2000356792 A	26-12-2000
			EP 1069450 A2	17-01-2001
			US 6449081 B1	10-09-2002
WO 03069380	A	21-08-2003	WO 03069380 A1	21-08-2003