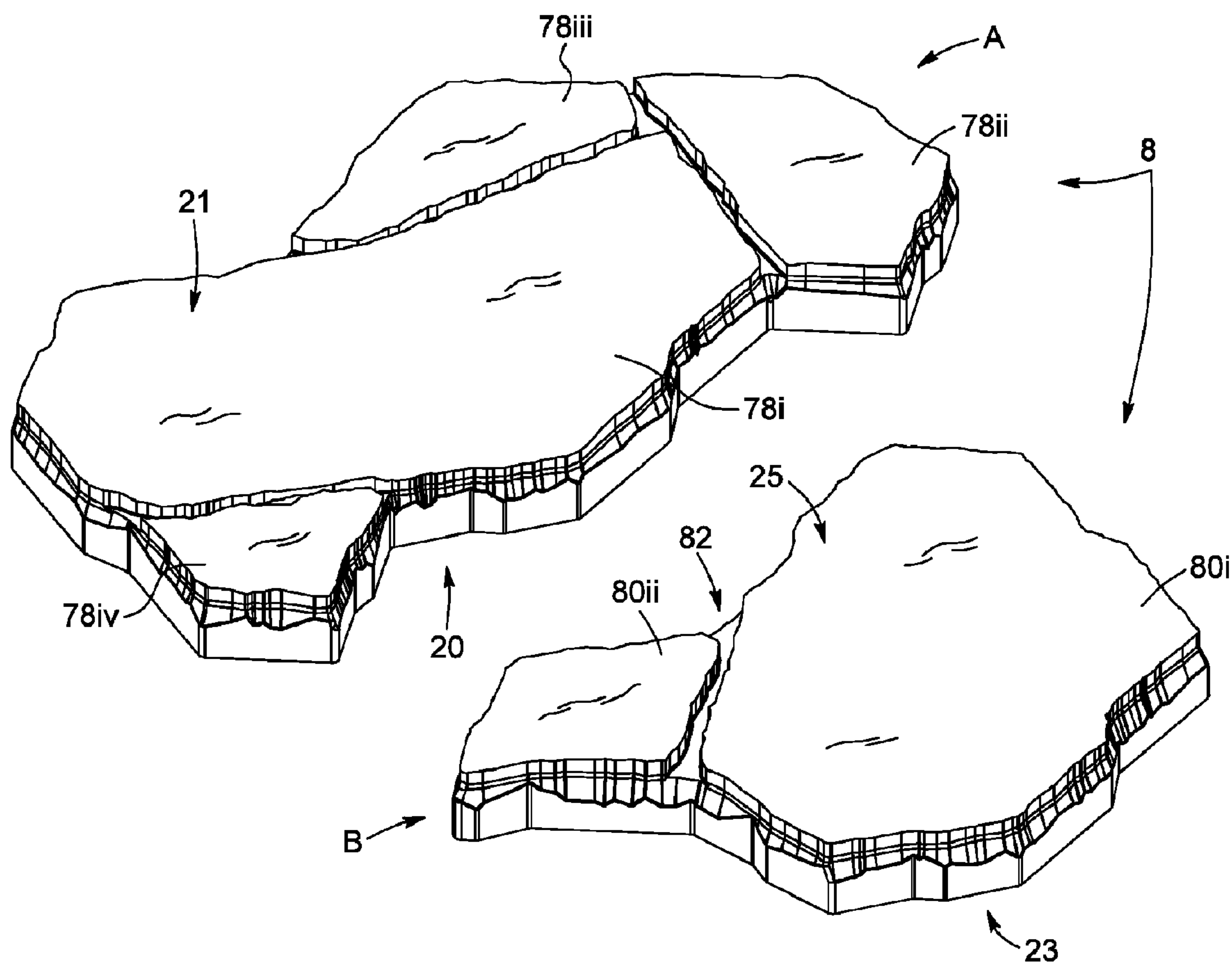




(86) **Date de dépôt PCT/PCT Filing Date:** 2013/06/17  
 (87) **Date publication PCT/PCT Publication Date:** 2013/12/27  
 (45) **Date de délivrance/Issue Date:** 2015/08/18  
 (85) **Entrée phase nationale/National Entry:** 2014/11/10  
 (86) **N° demande PCT/PCT Application No.:** CA 2013/050463  
 (87) **N° publication PCT/PCT Publication No.:** 2013/188971  
 (30) **Priorité/Priority:** 2012/06/18 (US61/661,008)

(51) **Cl.Int./Int.Cl. E01C 5/06** (2006.01),  
**B44F 9/04** (2006.01), **E01C 5/00** (2006.01)  
 (72) **Inventeurs/Inventors:**  
DIGNARD, STEPHANE, CA;  
PENTERMAN, JOHN, CA  
 (73) **Propriétaire/Owner:**  
OLDCASTLE BUILDING PRODUCTS CANADA INC.,  
CA  
 (74) **Agent:** ROBIC

(54) **Titre : SYSTEME DE PAVAGE A DEUX UNITES**  
 (54) **Title: DUAL-UNIT PAVING SYSTEM**



(57) **Abrégé/Abstract:**

A dual-unit paving system for covering a surface is provided. The system comprises pairs of first and second units. For each pair, the first and second unit have different respective shapes and sizes, and are configured to be matingly engageable for forming a

**(57) Abrégé(suite)/Abstract(continued):**

hexagonal assembly having six, non-linear sides. The hexagonal assembly allows forming rotational tessellations. The first and second units are also shaped and configured to be matingly engageable so as to form horizontally aligned tessellations, and also vertically aligned tessellations.

(12) INTERNATIONAL APPLICATION PUBLISHED UNDER THE PATENT COOPERATION TREATY (PCT)

(19) World Intellectual Property  
Organization  
International Bureau(10) International Publication Number  
**WO 2013/188971 A1**(43) International Publication Date  
27 December 2013 (27.12.2013)

## (51) International Patent Classification:

E01C 5/06 (2006.01) E01C 5/00 (2006.01)  
B44F 9/04 (2006.01)

## (21) International Application Number:

PCT/CA2013/050463

## (22) International Filing Date:

17 June 2013 (17.06.2013)

## (25) Filing Language:

English

## (26) Publication Language:

English

## (30) Priority Data:

61/661,008 18 June 2012 (18.06.2012) US

(71) Applicant: **OLDCASTLE BUILDING PRODUCTS CANADA INC.** [CA/CA]; 44, Chipman Hill, 10th Floor, Saint-John, New Brunswick E2L 4S6 (CA).(72) Inventors: **DIGNARD, Stéphane**; 1123, Henri M.-Perrault, Montréal, Québec H1A 5K3 (CA). **PENTERMAN, John**; 5340, rue Mentana app.6, Montréal, Québec H2J 3C5 (CA).(74) Agent: **ROBIC, LLP**; Centre CDP Capital, Bloc E - 8th Floor, 1001 Square-Victoria, Montreal, Québec H2Z 2B7 (CA).

(81) Designated States (unless otherwise indicated, for every kind of national protection available): AE, AG, AL, AM, AO, AT, AU, AZ, BA, BB, BG, BH, BN, BR, BW, BY, BZ, CA, CH, CL, CN, CO, CR, CU, CZ, DE, DK, DM, DO, DZ, EC, EE, EG, ES, FI, GB, GD, GE, GH, GM, GT, HN, HR, HU, ID, IL, IN, IS, JP, KE, KG, KN, KP, KR, KZ, LA, LC, LK, LR, LS, LT, LU, LY, MA, MD, ME, MG, MK, MN, MW, MX, MY, MZ, NA, NG, NI, NO, NZ, OM, PA, PE, PG, PH, PL, PT, QA, RO, RS, RU, RW, SC, SD, SE, SG, SK, SL, SM, ST, SV, SY, TH, TJ, TM, TN, TR, TT, TZ, UA, UG, US, UZ, VC, VN, ZA, ZM, ZW.

(84) Designated States (unless otherwise indicated, for every kind of regional protection available): ARIPO (BW, GH, GM, KE, LR, LS, MW, MZ, NA, RW, SD, SL, SZ, TZ, UG, ZM, ZW), Eurasian (AM, AZ, BY, KG, KZ, RU, TJ, TM), European (AL, AT, BE, BG, CH, CY, CZ, DE, DK, EE, ES, FI, FR, GB, GR, HR, HU, IE, IS, IT, LT, LU, LV, MC, MK, MT, NL, NO, PL, PT, RO, RS, SE, SI, SK, SM, TR), OAPI (BF, BJ, CF, CG, CI, CM, GA, GN, GQ, GW, KM, ML, MR, NE, SN, TD, TG).

## Published:

— with international search report (Art. 21(3))

(54) Title: DUAL-UNIT PAVING SYSTEM

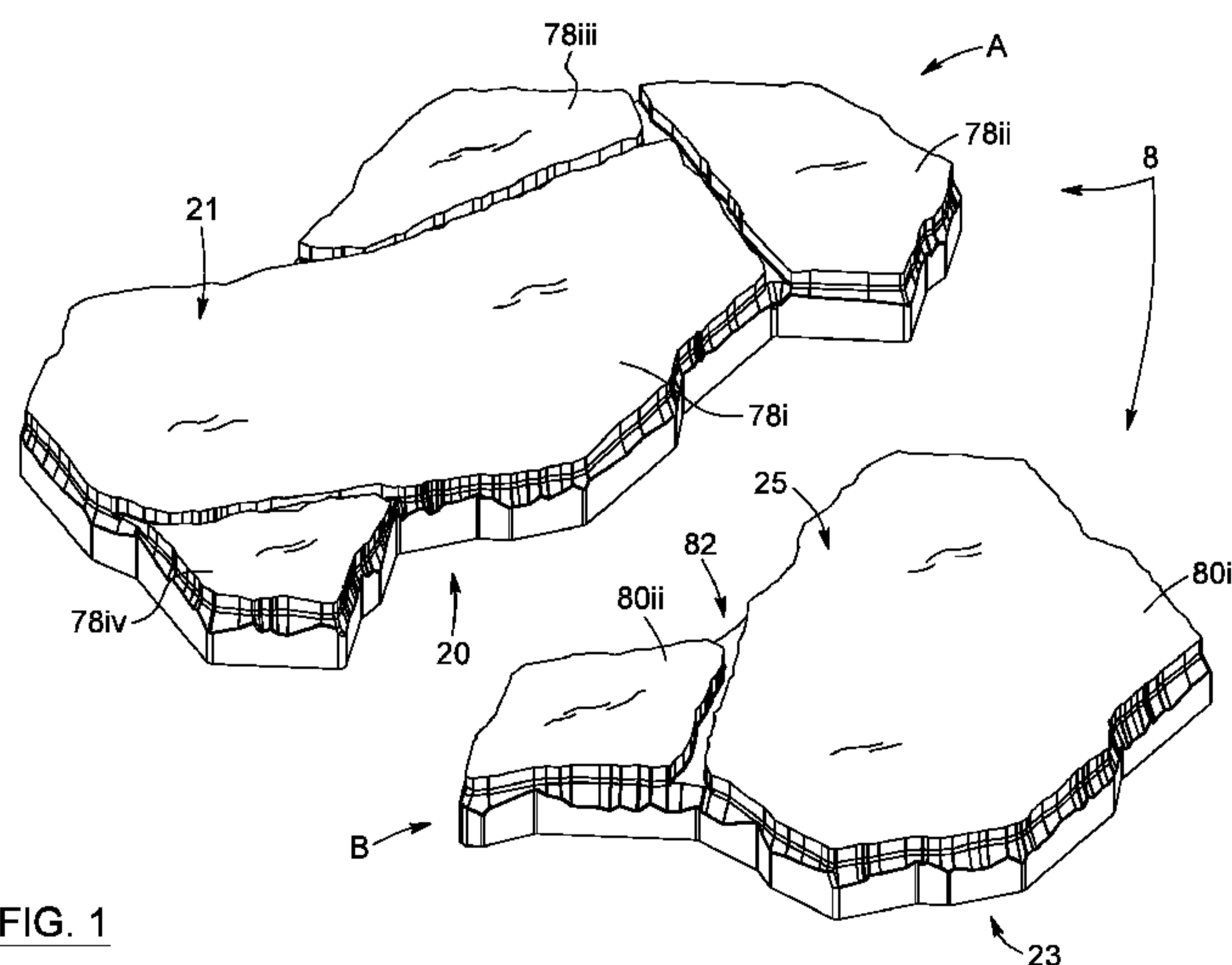


FIG. 1

(57) Abstract: A dual-unit paving system for covering a surface is provided. The system comprises pairs of first and second units. For each pair, the first and second unit have different respective shapes and sizes, and are configured to be matingly engageable for forming a hexagonal assembly having six, non-linear sides. The hexagonal assembly allows forming rotational tessellations. The first and second units are also shaped and configured to be matingly engageable so as to form horizontally aligned tessellations, and also vertically aligned tessellations.

WO 2013/188971 A1

## DUAL-UNIT PAVING SYSTEM

### FIELD OF THE INVENTION

The present invention relates generally to the field of paving units and artificial stones or flagstones for laying out pavements and is more particularly directed to such stones giving the  
5 resulting pavement a random and natural-looking appearance.

### BACKGROUND OF THE INVENTION

Artificial covering units made of concrete are well-known to lay out pavements or covering wall surfaces on residential or commercial properties, for example defining the surface of walkways or patios. Such stones are advantageously relatively inexpensive to make, as opposed to natural  
10 carved flagstones, but the resulting pattern is often repetitive or has what is called in this field an unnatural "linear line effect". Great efforts have been made to design artificial covering units which provide a more natural look, while still retaining the ease in their manufacture. It is worth mentioning that the expressions "covering unit", "stone" and "flagstone" are used throughout the present description without distinction to define a unit used as a paving or as a building material.

15 Attempts have been made in the past to develop sets of artificial stones comprising stones of different shapes used in combination with each other for paving a surface. The natural random look in those cases is obtained by combining artificial stones of different shapes. However a major drawback with those sets is that they often become a real puzzle for the user to install and combine the stones in a proper way. Another drawback is that currently existing systems are  
20 limited in terms of possible types of installation. Most systems allow installation of the units according to either one of the rotational or the linear tessellation principle, but few offer the possibility of installing the units by rotation or linearly (by "running bond" or "stack bond").

There is currently a need in the market for larger artificial stones, since they tend to provide a more natural and esthetic look. Larger artificial stones also provide better coverage per unit.  
25 However, one drawback of larger stones is that they are also generally heavier.

Known to the Applicant is US Patent 7,637,688, which describes a building unit made of primary elements which are rotational tessellation of one another. Since the building units are all based on a primary element, pavements created with such units tend to have a discernible pattern.

Also known to the Applicant is US design D602173. This design shows two units which can be paired to form a hexagonal shape. While the paired units allow the creation of pavement with a rotational tessellation, it does not allow assemble the units in a stack bond or running bond configurations.

5

Thus, there is presently a need for a paving system that provides a natural random look, while at the same time being easy to manufacture at a reasonable cost, and easy to install for any unskilled person in either one of linear and rotational tessellations.

## 10 **SUMMARY OF THE INVENTION**

Hence, in light of the aforementioned, there is a need for a paving system including units for use in combination with other units for covering a surface with a natural random look, which by virtue of their design and components, would be able to overcome some of the above-discussed concerns.

15

In accordance with the present invention, there is provided a dual-unit paving system for covering a surface. The system comprises pairs of first and second units. For each pair, the first unit has a lower face for facing the ground, an exposed upper face, and sidewalls extending from the lower face. The sidewalls of the first unit include a top side, a bottom side, a left side and a right side.

20

The second unit has a lower face for facing the ground, an exposed upper face and sidewalls extending from the lower face. The sidewalls of the second unit include a top side, a bottom side, a left side and a right side.

25

The bottom side of the first unit has a non-linear, irregular outline matingly engageable with an outline of the top side of the second unit for forming a hexagonal assembly. The hexagonal assembly formed by units A and B has six non-linear sides. This hexagonal assembly allows to form rotational tessellations.

30

The left side and the right side of the second unit have non-linear, irregular outlines matingly

engageable to at least respective portions of outlines of the right side and left side of the first unit.

5 The outline of the bottom side of the first unit comprises the outline of the top side of the first unit and the outline of the top side of the second unit comprises the outline of the bottom side of the second unit, for forming linear assemblies.

10 The first and second units forming the paving system can be installed either by rotational tessellation or by linear tessellation.

In one embodiment, the first and second units of a pair are created by dividing a corresponding hexagonal shape along an irregular separation line extending proximate the first vertex towards a location proximate the fourth vertex.

15 In one embodiment, the separation line delimiting the first and the second units includes a segment which is parallel and substantially similar to the outline of the side extending between the second and third vertices of the module. The separation line can be obtained by performing a linear transposition of the top segment of the first unit. The first unit includes the second and third vertices and a top side having an outline corresponding to the separation line. The second  
20 unit includes the fifth and sixth vertices and a bottom side having an outline corresponding to the separation line.

25 In one embodiment, for each paving module, the first side is concave and the second side is convex.

In one embodiment, the separation line extends from a location between the first and sixth vertex, closer to the first vertex, to a location between the fourth and fifth vertex, closer to the fourth vertex of an hexagonal assembly.

30 In one embodiment, each of the first and second units of a paving module comprises a top and a bottom side, and second unit being shaped such that when laid over the first unit, the top and bottom sides of the second unit coincide with the top and bottom sides of the first unit.

In one embodiment, the first and second units are provided with respective top faces, said top faces including at least two patterns of a flagstone, the patterns of the first unit differing from the patterns of the second unit. Preferably, the patterns are delimited by deep joints.

5 In one embodiment, the dual-unit paving system includes at least two groups of two first units and two second units, as defined above. In this paving system, the top face of the first unit differs from the top face of the first unit. Similarly, the top face of the second unit differs from the top face of the second unit. The paving system thereby allows the creation of four or more different paving modules, each module having a distinct top face.

10

In one embodiment, the paving system includes several groups of paired modules. The first and second units of the paving system can be installed linearly, by alternating the first and second modules.

15 The paving system according to the invention can advantageously be used for creating patio, pathways, sidewalks or stepping stones.

The present invention is also very advantageous for the manufacturer. The first and second unit of the paving system can be placed either one facing the other or side by side, thus optimizing  
20 the clamping operation during the manufacturing process.

Advantageously, the paving units can be assembled and installed either by rotational tessellation or by linear tessellation, with little or no "linear effect". Advantageously, with a paving system including two groups of first and second units as defined above, twelve different module  
25 configurations can be created when the units are installed according to the rotational tessellation principle. By using two different units matable with one another into a paving module, a multitude of different designs can be created, either by rotational or linear tessalation, in stack or running bond configurations.

### 30 **BRIEF DESCRIPTION OF THE DRAWINGS**

Other objects, advantages and features of the present invention will become more apparent upon reading the following non-restrictive description of preferred embodiments thereof, given

for the purpose of exemplification only, with reference to the accompanying drawings in which:

Figure 1 is a perspective view of a dual-unit paving system, according to an embodiment.

Figure 2A is a top plan view of the first unit of the paving system of Figure 1. Figure 2B is a top plan view of the second unit of the paving system of Figure 1.

5 Figure 3 is a schematic top view of the first and second units of the dual-unit paving system of Figure 1, facing one another and forming a hexagonal assembly, according to an embodiment. Figure 3A is a top view of the outline of the bottom side of the first unit or of the outline of the top side of the second unit, according to an embodiment of the invention.

Figure 4A is a schematic top view of the first and second units, placed side by side in first linear assembly. Figure 4B is schematic top view of the first and second units, placed side by side in a  
10 second linear assembly.

Figure 5 is a perspective view of unit B being placed over unit A. Figure 5A is a top view of unit A placed over unit B.

15 Figures 6A and 6B are schematic representations of the outer outline of the hexagonal assembly shown in Figure 3.

Figure 7A is a top view of two groups of pairs of units, according to an embodiment. Figure 7B is a top view of two groups of pairs of unit, according to another embodiment.

Figure 8 is a top view of different configurations of hexagonal assemblies, according to an embodiment of the invention.

20 Figure 9 is a top view of twelve different configurations of hexagonal assemblies.

Figure 10A are top views of another pavement made of different hexagonal assemblies placed in different orientations and shown assembled according to an embodiment of the invention. Figure 10B is a top view of a pavement made from different hexagonal assemblies having the same orientation and shown assembled according to an embodiment of the invention.

25 Figure 11 to 14 are top views of pavements made of first and second units assembled in different linear assemblies, according to different embodiments of the invention. Figures 12 and

13 show a pavement according to a stack bond configuration. Figure 14 show a pavement according to a running bond configuration.

## DESCRIPTION OF PREFERRED EMBODIMENTS

5 In the following description, similar features in the drawings have been given similar reference numerals. In order to preserve clarity, certain elements may not be identified in some figures if they are already identified in a previous figure.

10 It will be appreciated that positional descriptions such as "lower", "upper", "vertical", "horizontal", "top", "bottom", "side" and the like should, unless otherwise indicated, be taken in the context of the figures and should not be considered limiting or as implying a required orientation during use.

15 The dual-unit paving system advantageously allows the creation of different assemblies, according to linear or rotational tessellations. With only two different shapes of units, the system can provide the illusion of having been assembled randomly and created from natural flagstones. The present paving system also provides units which are as large as possible while remaining easy to install in different configurations. By "tessellation" it is meant a covering, tiling or paving of one or more shapes to cover a surface, without any substantial gaps between shapes.

20 Referring to Figure 1, a first unit A and a second unit B are shown. They form a pair of units A, B of a dual-unit paving system 8, for covering a surface. The first unit A has a lower face 20 for facing the ground, an exposed upper face 21, and sidewalls extending from the lower face 20.

The second unit B also has a lower face 23 for facing the ground, an exposed upper face 25 and sidewalls extending from the lower face 23.

25 Preferably, the upper exposed face 21, 25 of at least one of the first and second units A, B includes two or more different patterns 78i to 78iv and 80i, 80ii, which are preferably flagstone patterns. The patterns are preferably all different, so as to increase the randomness aspect of pavements created with the dual-unit paving system. The flagstones patterns are preferably delimited by deep joints 82.

Figure 2A is a top view of unit A. The sidewalls of unit A include a top side 12, a bottom side 14, a left side 16 and a right side 18. The terms “top”, “bottom”, “left” and “right” refer here to the orientation of the sides of unit as shown in Figure 2, which also corresponds to the orientation of the sides when looking at the unit over its upper, exposed face, such as when the unit is placed on the ground and one is looking at the unit directly over it. The terms “top”, “bottom”, “right” and “left” are used to facilitate and simplify reference to the different sides of the unit, and they could be referred as “first”, “second”, “third” and “fourth” sides as well.

The outline of each side 12, 14, 16, 18 is made of several segments at angle from one another. The outline of the sides is non-linear and irregular. By “irregular” it is meant that the sides include several segments and split deviations. Toward the lower face of the unit, the sides are made of several flat surfaces. The junction of the upper exposed face 21 of the unit with the sides is chiselled, so as to imitate natural carved stone.

Figure 2B is a top view of unit B. The sidewalls of unit B also include a top side 22, a bottom side 24, a left side 26 and a left side 28. The outline of each side is made of several angled segments. Similar to unit A, each side of unit B is made of several intersecting flat surfaces toward the lower face of the unit B and the junction of the sides with the upper exposed face 25 of the unit is chiselled. The different patterns can be colored and given a texture to imitate natural flagstones.

Referring to Figures 2A and 2B, and also to Figure 3, the bottom side 14 of the first unit A has a non-linear, irregular outline matingly engageable with the outline of the top side 22 of the second unit B. By “matingly engageable”, it is meant that the units can be assembled or paired, so that sides will closely fit one another. When units A and B are assembled so as to face one another, as shown in Figure 3, they form a hexagonal assembly 10 having six, non-linear sides. By “hexagonal” it is meant that the shape is reminiscent of a hexagon. The hexagonal assembly has an hexagon-based shape, with six sides and six angles.

Still referring to Figure 3, in this particular embodiment of the second unit B, the outline of the top side 22 includes a portion which corresponds to a vertical translation of the outline of the bottom side 24. This feature is also present in unit A, for which the outline of the bottom side 14 includes a portion which corresponds to a vertical translation of the outline of the top side 12. It

will also be appreciated that preferably, the outline of the top side 12 of the first unit A and adjacent segments 16i, 18i of the left and right sides 16, 18 correspond to a vertical translation of the outline of the bottom side 14 of the first unit A. By “vertical” translation it is meant that the translation is made substantially perpendicularly relative to the sides.

5

Still referring to Figure 3 and also to Figure 3A, the respective outlines of the top side 22 of the second unit B and of the bottom side 14 of the first unit A are preferably similar, and are referred to as a separation outline 52.

10 In this particular embodiment, the separation outline 52 includes two outer portions 54, 58 and one inner portion 56. This portion 56 has an outline similar to the bottom side 24 of the second unit B. Preferably, at least one of the outer and inner portions are formed by several non-linear segments, such as for portions 54 or 56 of the separation line. Still preferably, the separation line has two summits 60, 62 and a valley 64 between the two summits 60, 62. In this  
15 embodiment, summit 60 has a first segment and a second segments 66, 68 extending from it, the first segment 66 being a rotational image of the second segment 68. Similarly, summit 62 has first and second segments 70, 72 being rotational images of one another.

Still referring to Figure 3, it is preferable that the units A and B have approximately the same  
20 height h. This height h is measured on unit A from the highest point on side 12 to the highest point of side 14. Similarly, the height h of unit B is measured from the highest point on side 22 to the highest point of side 24. Of course, the term “highest” is to be taken in the context of the Figures, and relates to a vertical or “Y” axis.

25 Referring to Figure 3 and 3A, as can be appreciated, the first and second units A and B are formed by dividing the hexagonal shape 10 in two different and distinct units A and B. The separation line 52 used for forming the units A, B is located approximately halfway between the highest point and the lowest point of the hexagonal assembly 10. The separation line 52 includes within its profile a portion of the perimeter of the hexagonal outline, transposed or  
30 translated linearly along a central axis of the assembly 10. It will also be noted that the inner portion 56 of the separation line 52 includes the outline of the sides of the hexagonal shape 10. The remaining portions 54, 58 of the separation line 52 also correspond to other sections of the outline of the hexagonal shape.

Referring to Figures 4A and 4B, two different linear assemblies 11 are shown. As can be appreciated, the left side 26 and the right side 28 of the second unit B have non-linear, irregular outlines matingly engageable to at least respective portions 50, 48 of the outlines of the right side 18 and left side 16 of the first unit A. For example, such linear assemblies 11 can be used  
5 to form pathways. In this case, the linear assemblies are oriented horizontally

Referring to Figures 4A, the outline of the bottom side 14 of the first unit A includes the outline of the top side 12 of the first unit A and the outline of the top side 22 of the second unit B includes the outline of the bottom side 24 of the second unit B. This allows the units to form linear  
10 assemblies along a vertical orientation as well. Units A can be stacked vertically, in a stack bond configuration, and so can units B.

In addition, the top side 12 of the first unit A is preferably substantially similar to the bottom side of 24 of the second unit B, so that hexagonal assemblies can be stacked vertically, such as  
15 shown in Figure 10B.

Referring to Figures 5 and 5A, the second unit B is shaped such that when laid over the first unit A, the top and bottom sides 22, 24 of the second unit B coincide with the top and bottom sides 12, 14 of the first unit A. In other words, when the second paving unit B is placed over the first  
20 paving unit A, it fits perfectly within the outline of the first unit A. Both top and bottom sides of units A and B coincide with one another. Unit B is smaller in size than unit A. In other words, the top surface of unit B is smaller than the top surface of unit A. The volume and weight of unit B are also smaller than the volume and weight of unit A.

Referring now to Figures 6A and 6B, different aspects of the hexagonal assembly 10 formed by  
25 units A and B are shown. The outline of the hexagonal assembly 10 formed by units A and B has six sides 36, 38, 40, 42, 44 and 46. They form three pairs of sides 30, 32 and 34. The hexagonal assembly 10 has first 1, second 2, third 3, fourth 4, fifth 5 and sixth 6 consecutive vertices, and the separation outline 52 preferably extends from near the first vertex 1 to near the fourth vertex 4. It will be also noted that each of the sides of the hexagonal assembly 10 is  
30 formed by several segments at angle from one another, and the outline of a side does not include any repetitive portion or segment. This feature allows creating pavements with a more random, irregular aspect.

Adjacent sides of the hexagonal assembly preferably spaced apart by an angle of approximately 120°, and the six sides 36, 38, 40, 42, 44 and 46 are preferably congruent. By "congruent", it is meant that the sides are superposable, so as to be coincident throughout.

- 5 When the first and second units A, B are facing one another to form the hexagonal assembly 10, two adjacent sides of the hexagonal assembly preferably comprise a convex side 36, 40, 44 and a concave side 38, 42, 46. This characteristic allows the assemblies to interlock with one another when forming a pavement by rotational tessellation of such assemblies, and thus results in a more stable installation.

10

Referring now to Figures 7A and 7B, pairs of units A1 – B1; A2 – B2; A1' – B1' and A2' – B2' are preferably divided into first 84, 84' and second 86, 86' groups. In Figure 7A, the upper faces 74 of the first unit A1 differs from the upper face 88 of the first unit A2. Similarly, the upper face 76 of the second unit B1 differs from the upper face 90 of the second unit B2. Of course, in other  
15 embodiments of the invention, the dual-unit paving system can include three or more groups of different pairs of units A, B. The number of different possible combinations PC is obtained by multiplying the number of first paving units (type A) by the number of second paving units (type B); and  $N_{bA} \times N_{bB} = PC$ . Preferably, the surface area of the flagstone patterns of unit A is substantially similar to the surface area of either one of the exposed face of second unit B, or of  
20 one of the patterns of unit B.

Advantageously, the specific shape given to the units facilitates the "clamping" of the units, during the manufacturing of the units. During the manufacturing process, after unmolding and curing the units and prior to packaging them, the units must be clamped with large clamps and  
25 placed over pallets for wrapping. The specific configuration of the first and second units A and B allows to assemble them such that the space occupied by the units on the pallets is maximized, thus facilitating their handling.

As shown in Figure 8, this characteristic of the dual-unit paving system allows creating four  
30 different hexagonal assemblies 10i, 10ii, 10iii, 10iv. Each assembly has a distinct upper face appearance.

Referring to Figure 9, the four hexagonal assemblies 10i, 10ii, 10iii and 10iv can be positioned according to three different angles of rotation: 0°, 120° and 240°. The dual-unit system thereby allows the creation of twelve different configurations of hexagonal assemblies.

5

As shown in Figure 10A, a pavement 92 obtained by a rotational tessellation of different hexagonal assemblies obtained with units A1, B1, A2 and B2 has a random aspect, without any repeating pattern. The rotational tessellation is obtained by tessellating several paired units A and B in different rotational orientations. In addition, the deep joints of the units A and B are located on their respective top faces so as to “break” the linear effect when the units are rotated.

10

As shown in Figure 10A, the combination of a rotational installation of the units, with the appropriate positioning of the deep joints, results in a more random and natural installation than the one presented in Figure 10B. It is also more difficult to distinguish a linear pattern.

Of course, it is also possible to create a pavement 92' without rotating the units, and by assembling units A and B from the same or from different groups, as in Figure 10B.

15

Referring to Figures 11 to 14, other possible pavements formed by a linear tessellation of several pairs of first and second units A, B are shown. In these examples, the first and second units A, B of a pair are placed side by side. Figure 11 is an example of a horizontally aligned tessellation.

20

As shown in Figures 12 and 13, different pavements 94, 94' and 94'' are made using a stack bond configuration. The pavements include at least two rows, where the first units A1 or A2 of the first row face the respective first units A2 or A1 of the second row. Similarly, units B1 or B2 are facing units B2 or B1. Figure 13 is an example a vertically aligned tessellation.

25

In Figure 14, the pavement 96 is made using a running bond configuration. A running bond pavement includes at least two rows (in this particular case, three rows are used) where the first units A1 or A2 of the first row face the respective second units B1 or B2 of the second row.

30

As can be appreciated, the paving units of the present system allow creating, when combined, large paving modules or assemblies, having a random and natural look. Such large paving assemblies yet remain easy to install, since they are subdivided into smaller sub-units A and B,

and since the modules have a substantially similar outline. In addition, a single worker is generally able to lift and install the paving units. The result of combining the first and second paving units is larger looking stones having a random look which enables to loose the linear and hexagonal shape present in existing products. In addition, the specific perimeter or outline of  
5 each paving unit advantageously facilitates their clamping during the manufacturing process and allows maximization of the space occupied by the units on the pallets.

The scope of the claims should not be limited by the preferred embodiments set forth in the examples, but should be given the broadest interpretation consistent with the description as  
10 a whole.

**CLAIMS**

1. A dual-unit paving system for covering a surface, the system comprising:
  - pairs of first and second units wherein for each pair:
    - 5 the first unit has a lower face for facing the ground, an exposed upper face, and sidewalls extending from the lower face, the sidewalls of the first unit including a top side, a bottom side, a left side and a right side,
      - the second unit has a lower face for facing the ground, an exposed upper face and sidewalls extending from the lower face, the sidewalls of the second unit including a top side,
        - 10 a bottom side, a left side and a right side, the second unit having a shape different from a shape of the first unit;
          - the bottom side of the first unit has a non-linear, irregular outline matingly engageable with an outline of the top side of the second unit for forming a hexagonal assembly having six, non-linear sides, to form rotational tessellations;
          - 15 the left side and the right side of the second unit have non-linear, irregular outlines matingly engageable to at least respective portions of outlines of the right side and left side of the first unit, to form horizontally aligned tessellations, and
            - the outline of the bottom side of the first unit comprises the outline of the top side of the first unit, and the outline of the top side of the second unit comprises the outline of the bottom side of the second unit, to form vertically aligned tessellations.
            - 20
2. The dual-unit paving system according to claim 1, wherein the outline of the top side of the first unit is substantially similar to the outline of the bottom side of the second unit.
- 25 3. The dual-unit paving system according to claim 1 or 2, wherein the outline of the top side of the second unit comprises a portion which is a vertical translation of the outline of the bottom side of the second unit.
4. The dual-unit paving system according to any one of claims 1 to 3, wherein the outline of the bottom side of the first unit comprises a portion which is a vertical translation of the outline of the top side of the first unit.
- 30

5. The dual-unit paving system according to any one of claims 1 to 4, wherein the outline of the bottom side of the first unit is a vertical translation of the outline of the top side of the first unit and of adjacent segments of the right and left sides of the first unit.
- 5 6. The dual-unit paving system according to any one of claims 1 to 5, wherein the upper, exposed face of the second unit is smaller than the upper, exposed face of the first unit.
7. The dual-unit paving system according to any one of claims 1 to 6, wherein the first and second units have approximately the same height.
- 10 8. The dual-unit paving system according to any one of claims 1 to 7, wherein the respective outlines of the top side of the second unit and of the bottom side of the first unit are similar and referred to as a separation outline.
- 15 9. The dual-unit paving system according to claim 8 wherein the separation outline comprises two outer portions and one inner portion, said inner portion having an outline similar to the bottom side of the second unit.
- 20 10. The dual-unit paving system according to claim 9, wherein at least one of the outer and inner portions is formed by several non-linear segments.
- 25 11. The dual-unit paving system according to claim 10, wherein the separation line comprises two summits and a valley between the two summits.
- 30 12. The dual-unit paving system according to claim 11, wherein each of the two summits has a first segment and a second segment extending therefrom, the first segments being rotational images of the respective second segments.
13. The dual-unit paving system according to any one of claims 1 to 12, wherein the second unit is shaped such that when laid over the first unit, the top and bottom sides of the second unit coincide with the top and bottom sides of the first unit.
14. The dual-unit paving system according to claim 9, wherein when the first and second units of a pair are engaged to form the hexagonal assembly, the hexagonal assembly has first,

second, third, fourth, fifth and sixth consecutive vertices, the separation outline extending from near the first vertex to near the fourth vertex.

- 5 15. The dual-unit paving system according to any one of claims 1 to 14, wherein when the first and second units of a pair are facing one another to form the hexagonal assembly, adjacent sides of the hexagonal assembly are spaced apart by an angle of approximately 120°.
- 10 16. The dual-unit paving system according to any one of claims 1 to 15, wherein when the first and second units of a pair are facing one another to form the hexagonal assembly, the six sides of the hexagonal assembly are congruent.
- 15 17. The dual-unit paving system according any one of claims 1 to 16, wherein when the first and second units of a pair are facing one another to form the hexagonal assembly, two adjacent sides of the hexagonal assembly comprise a convex side and a concave side.
18. The dual-unit paving system according to any one of claims 1 to 17, wherein at least one of the first and second units has an upper, exposed face comprising two or more different patterns.
- 20 19. The dual-unit paving system according to claim 18, wherein the patterns are flagstone patterns.
- 25 20. The dual-unit paving system according to claim 19, wherein the upper, exposed faces of the first and second units comprise at least two different flagstone patterns, the patterns of the first unit differing from the patterns of the second unit.
21. The dual-unit paving system according to any one of claims 18 to 20, wherein the patterns are delimited by deep joints or by color.
- 30 22. The dual-unit paving system according to any one of claims 1 to 21, wherein:
- the pairs of units are divided into at least first and second groups;
  - the upper faces of the first units of the first group differ from the upper faces of the first units of the second group, and

- the upper faces of the second units of the first group differ from the upper faces of the second units of the second group;  
thereby allowing the creation of four hexagonal assemblies, each assembly having a distinct upper face appearance.

5

23. A pavement formed by a rotational tessellation of several pairs of first and second unit as defined in claim 22, the tessellation comprising several of the four hexagonal assemblies positioned according to three different angles of rotation, the pavement thereby comprising twelve different configurations of hexagonal assemblies.

10

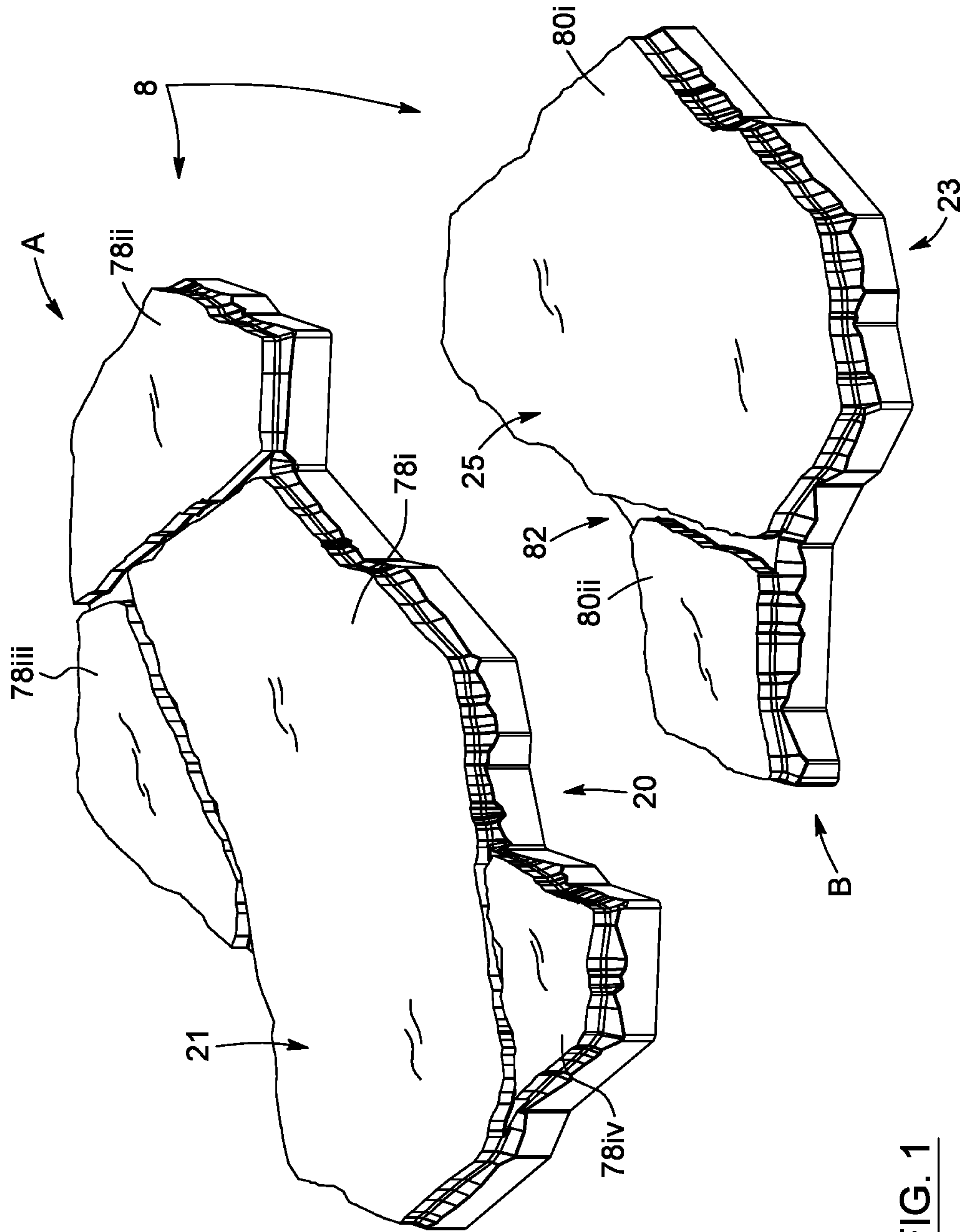
24. A pavement formed by a linear tessellation of several pairs of first and second units as defined in any one of claims 1 to 22, wherein first and second units of a pair are placed side by side.

15

25. A pavement according to claim 24, comprising at least a first row and a second row of units, wherein the first units of the first row face the respective first units of the second row in a stack bond configuration.

20

26. A pavement according to claim 24, comprising at least a first row and a second row of units, wherein the first units of the first row face the respective second units of the second row in a running bond configuration.



**FIG. 1**

2/15

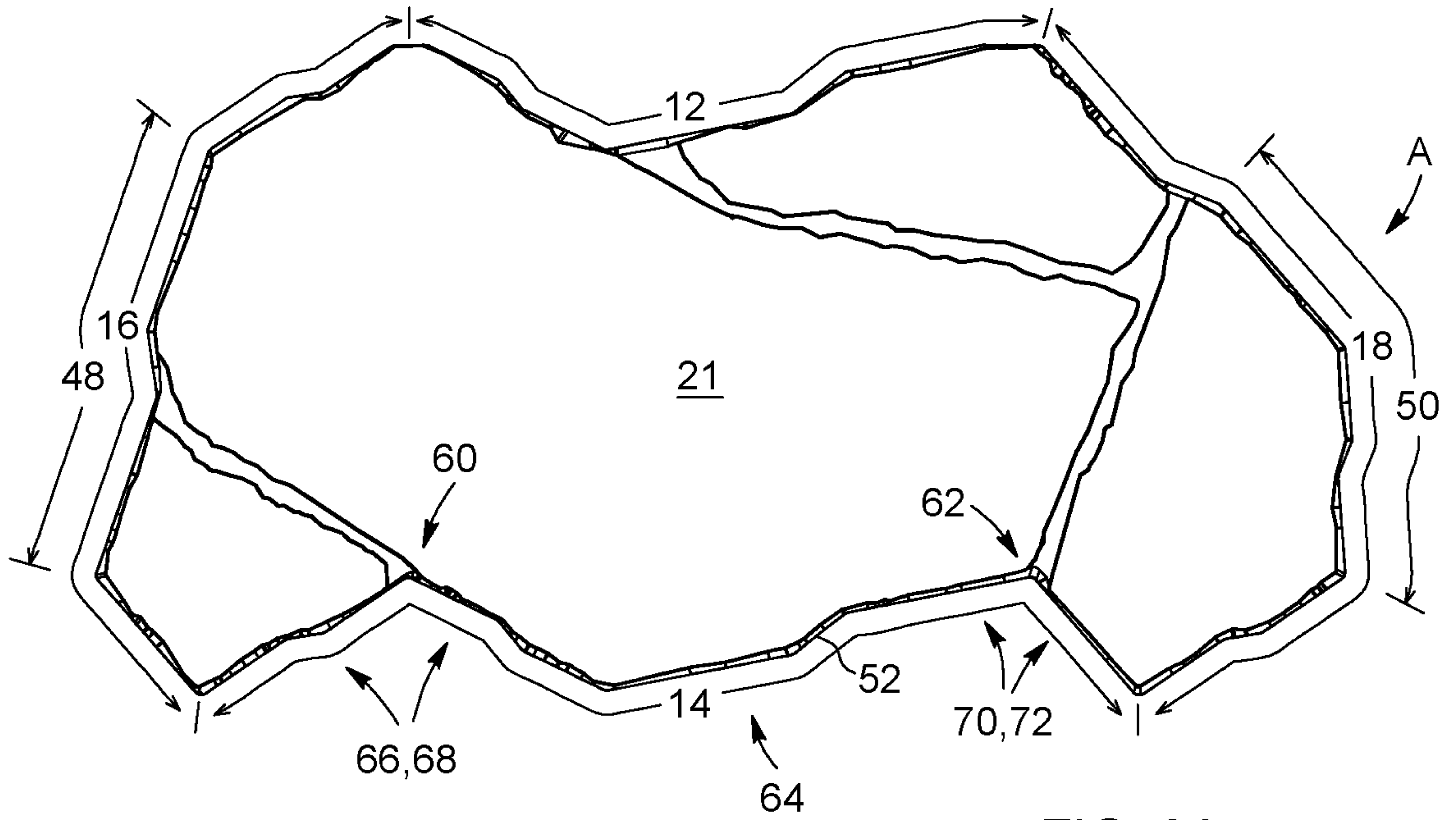


FIG. 2A

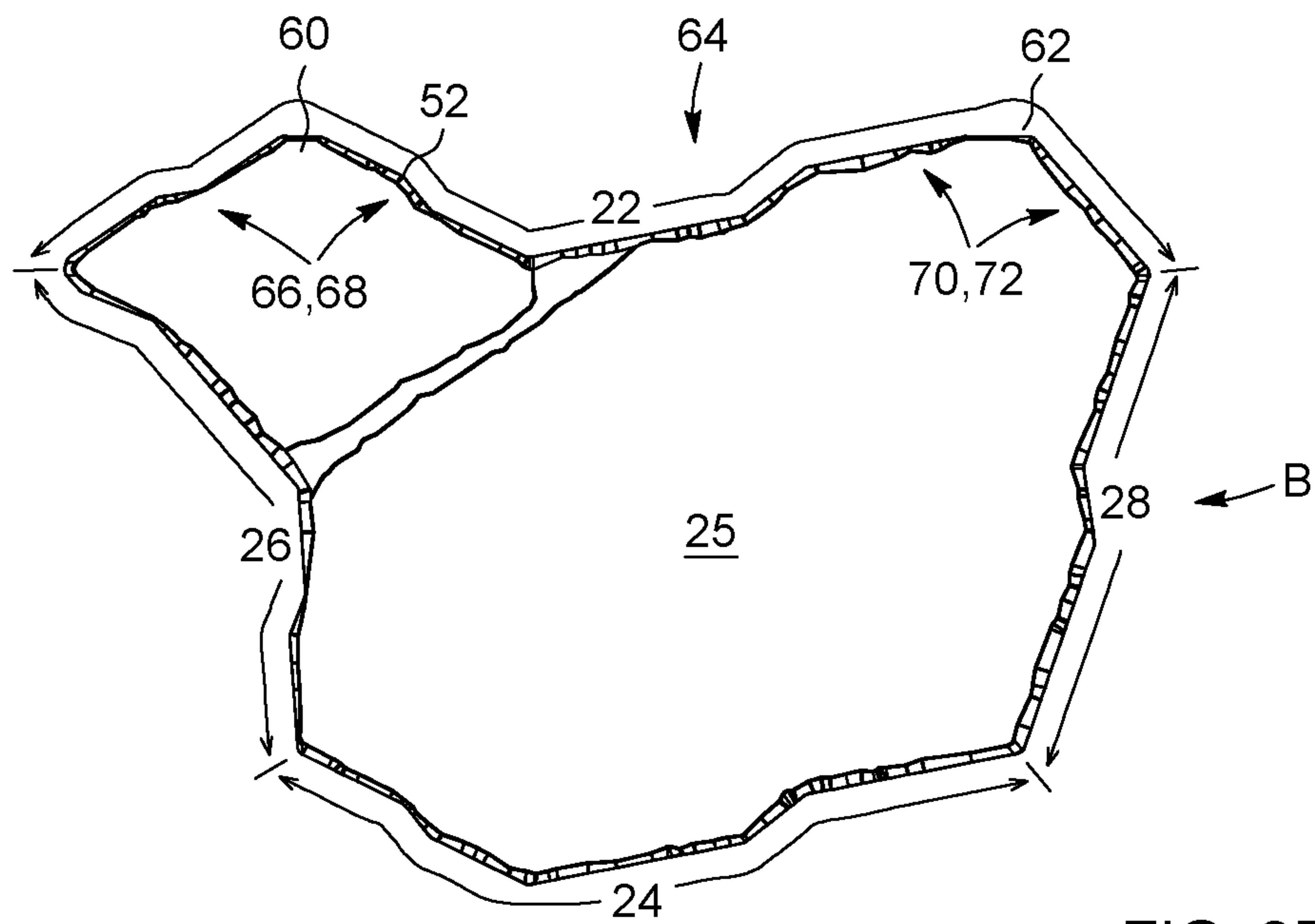


FIG. 2B

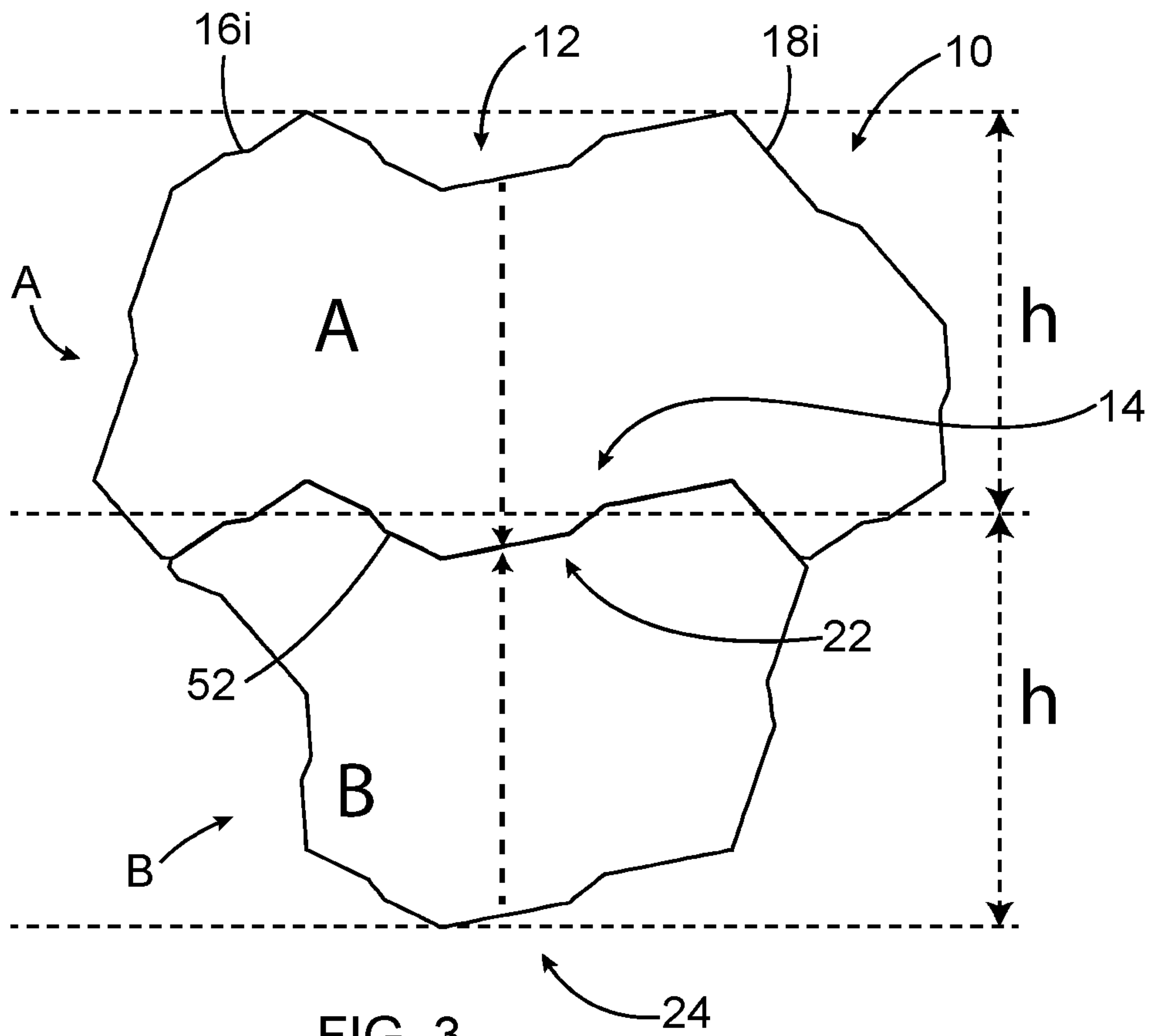


FIG. 3

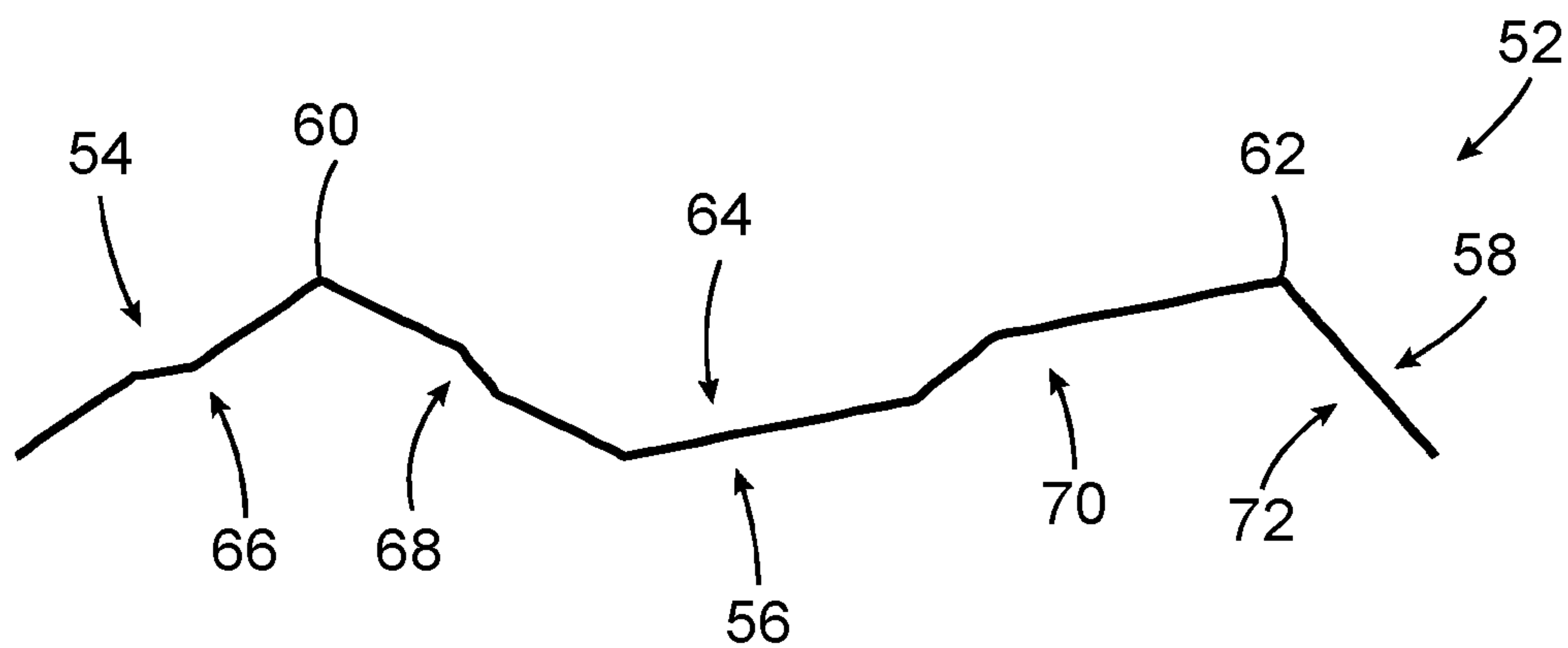


FIG. 3A

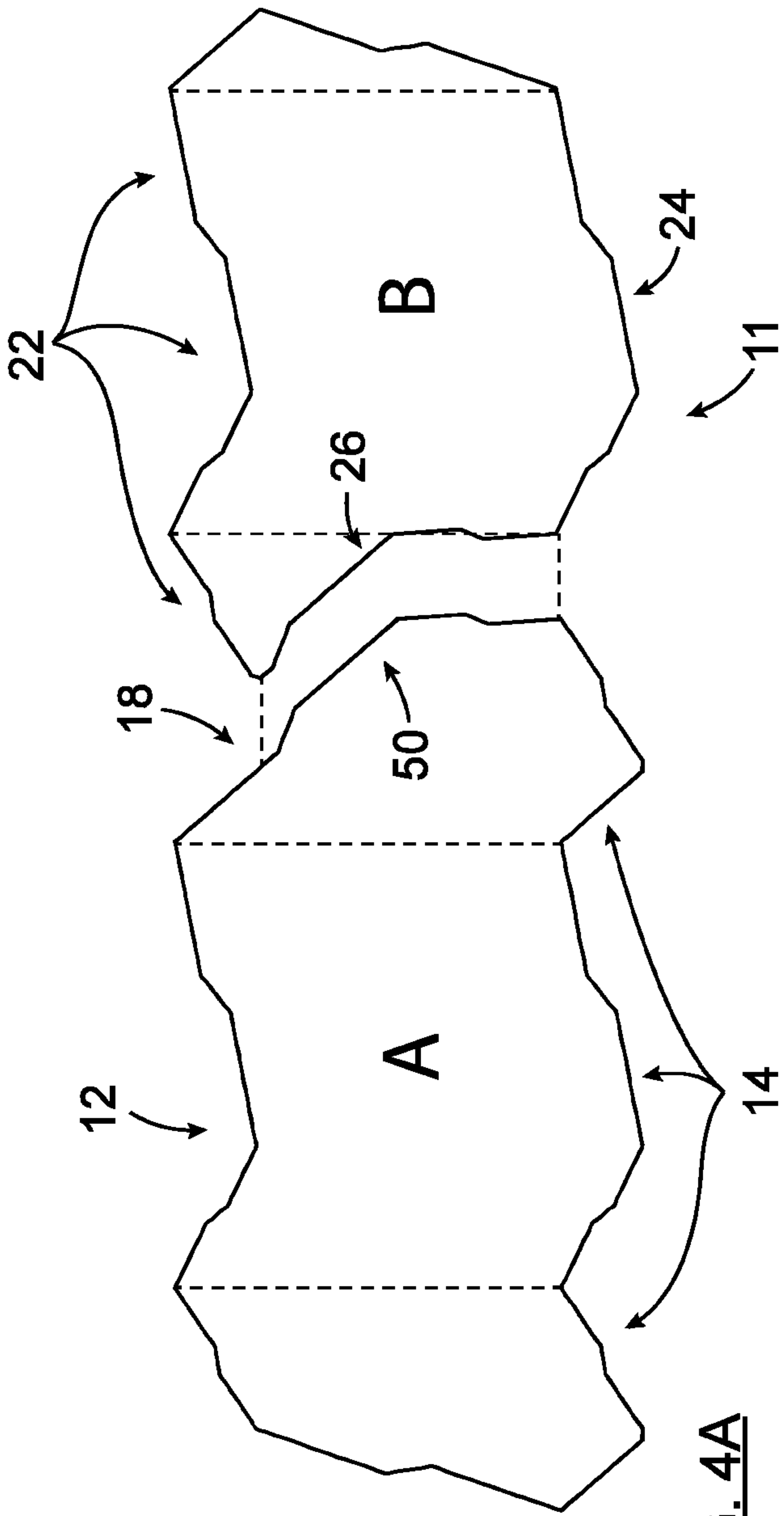


FIG. 4A

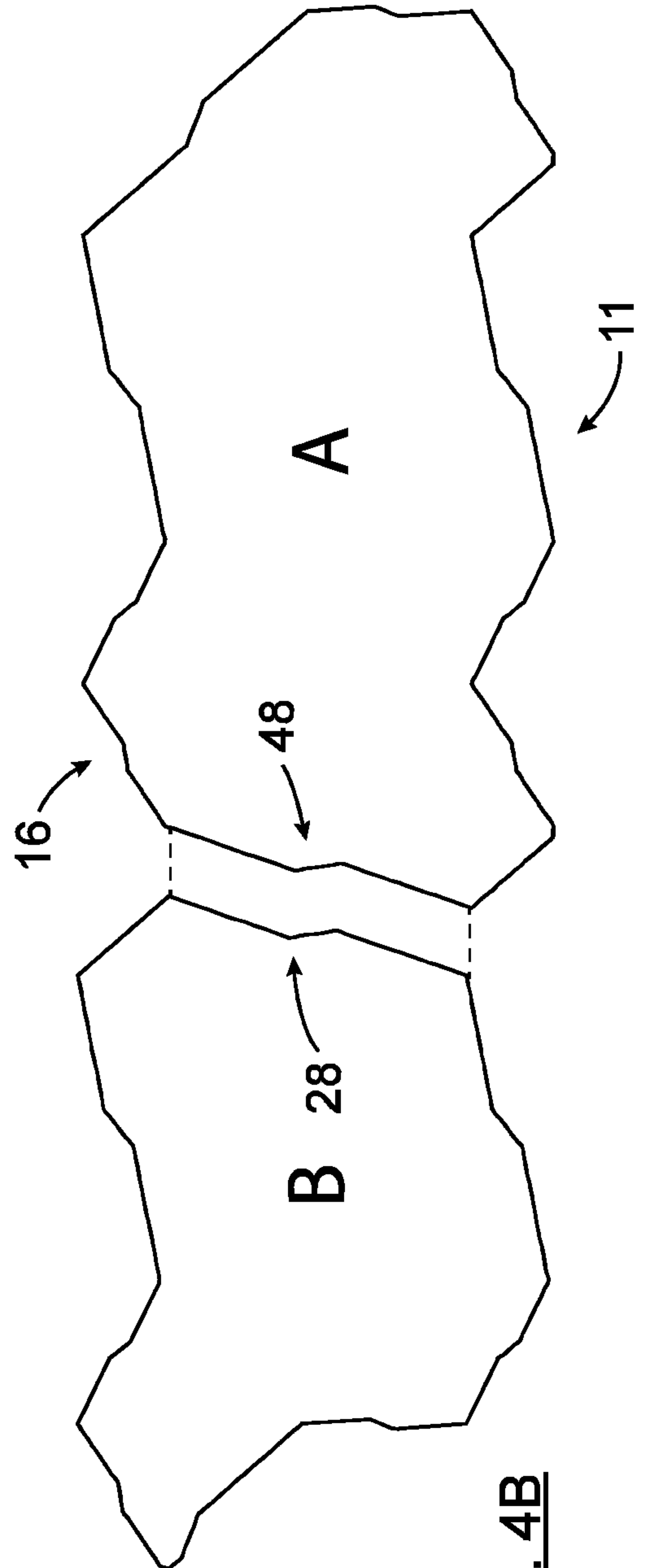


FIG. 4B

5/15

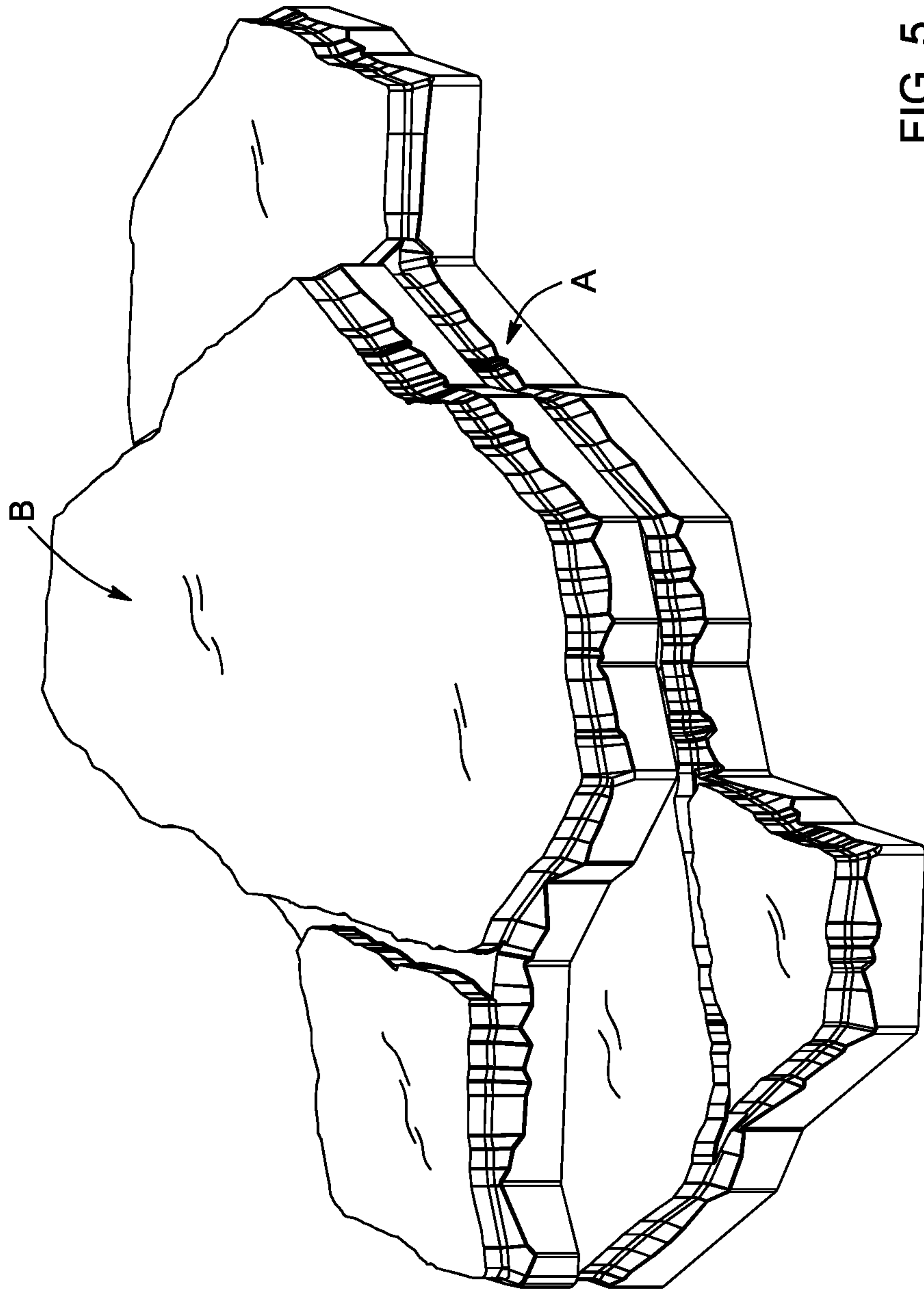


FIG. 5

6/15

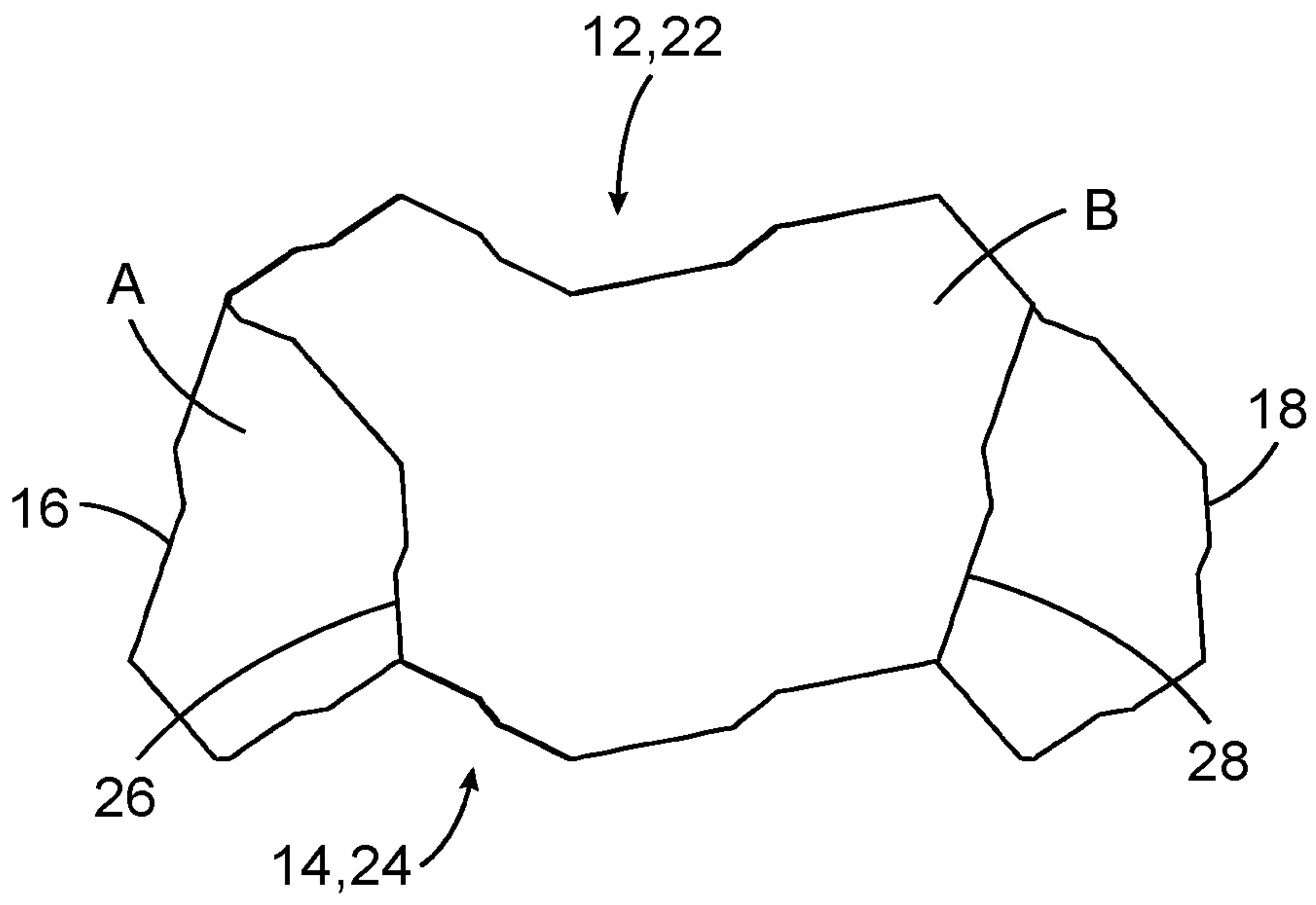
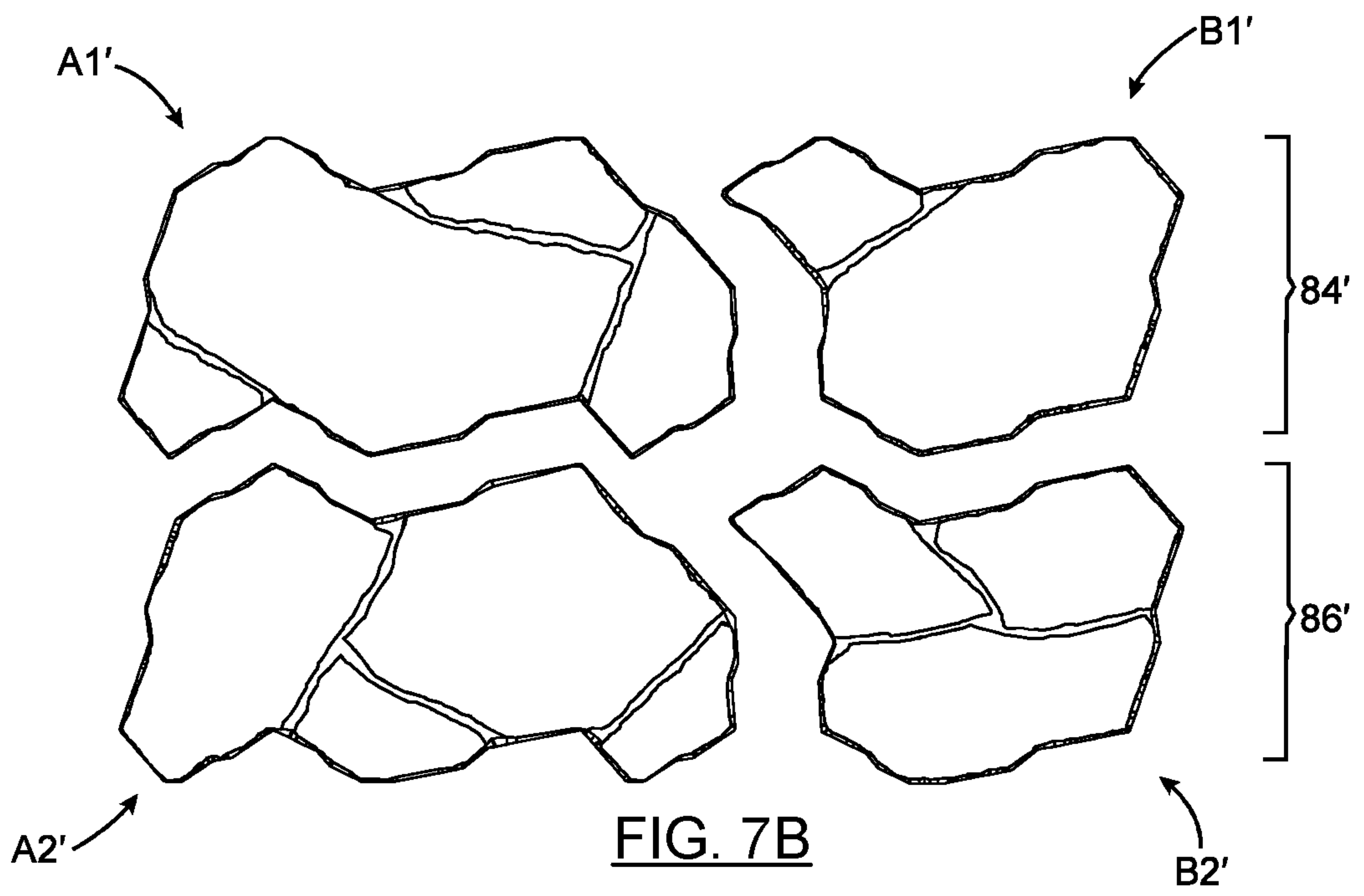
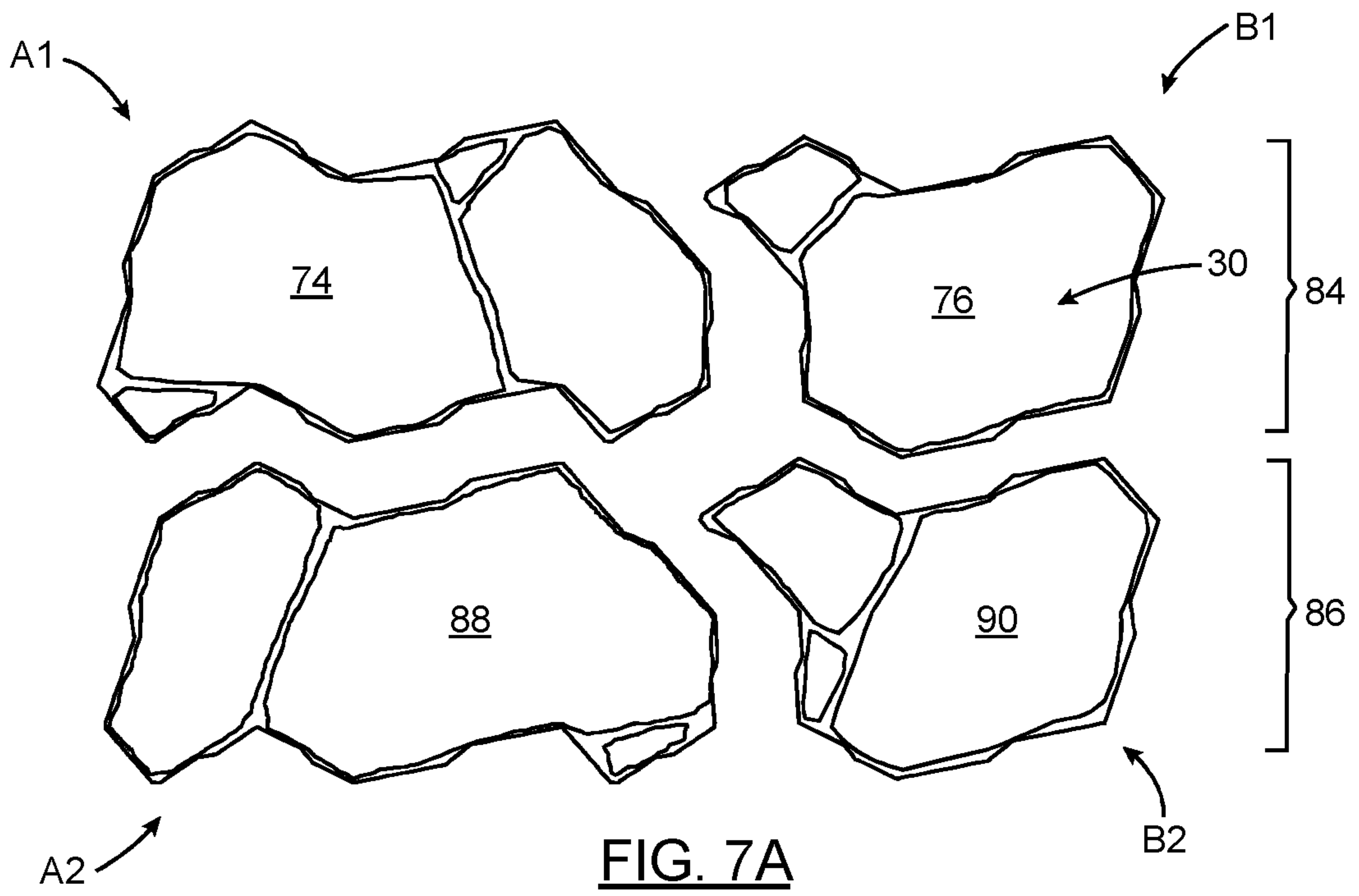
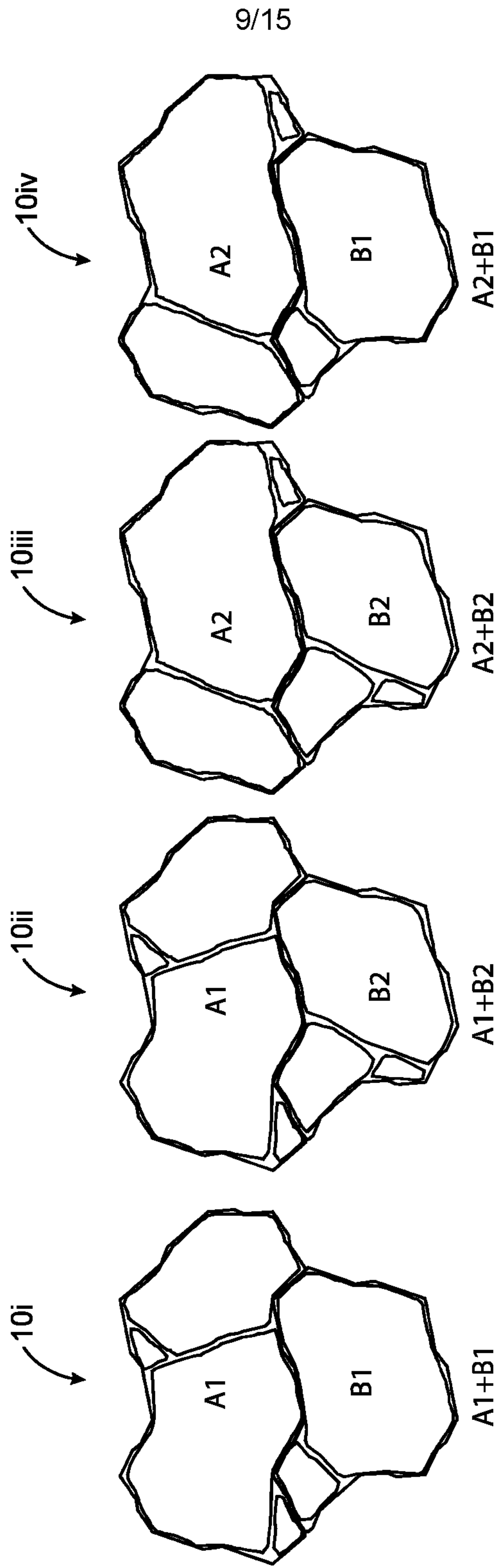


FIG. 5A



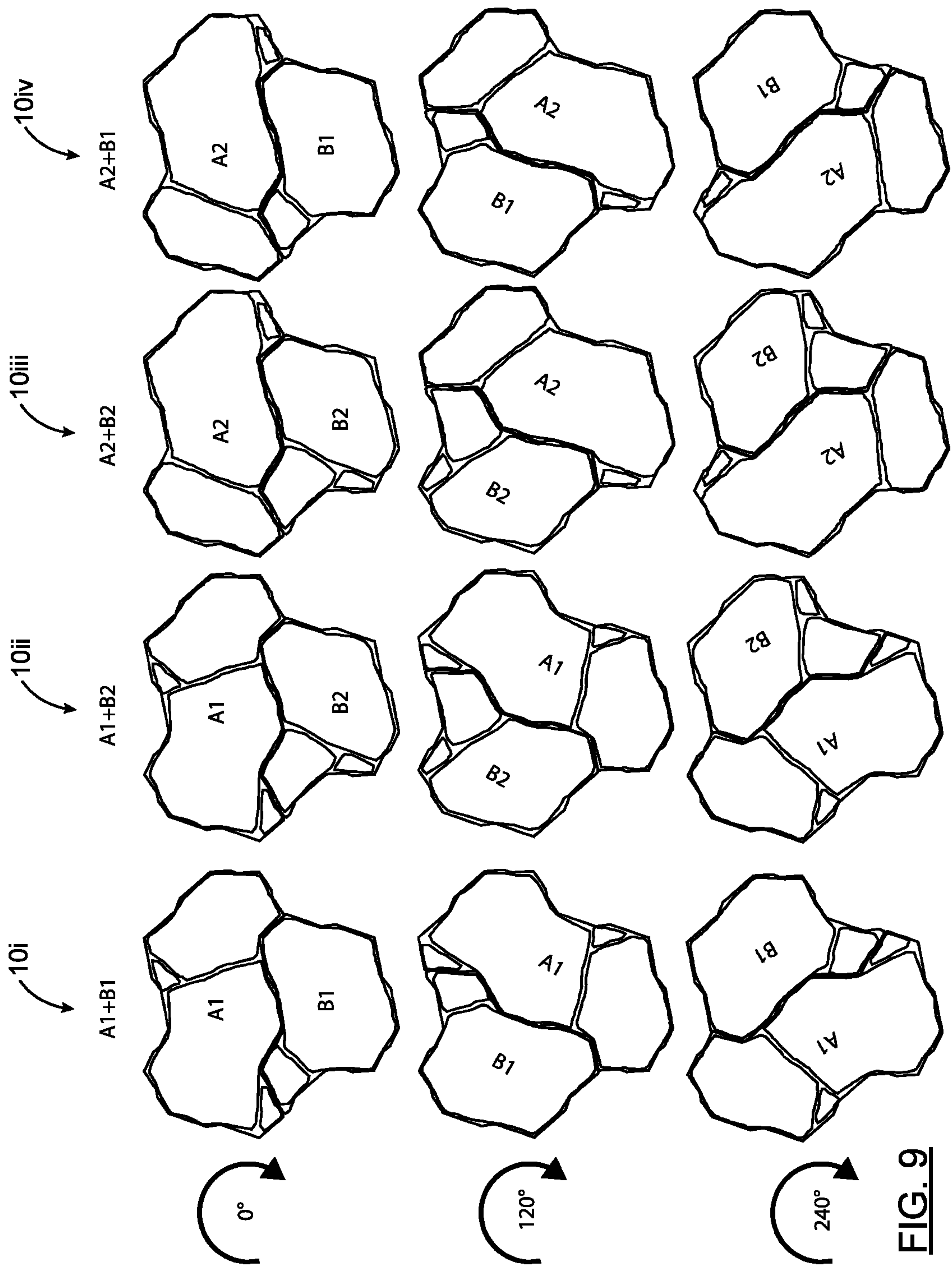
8/15



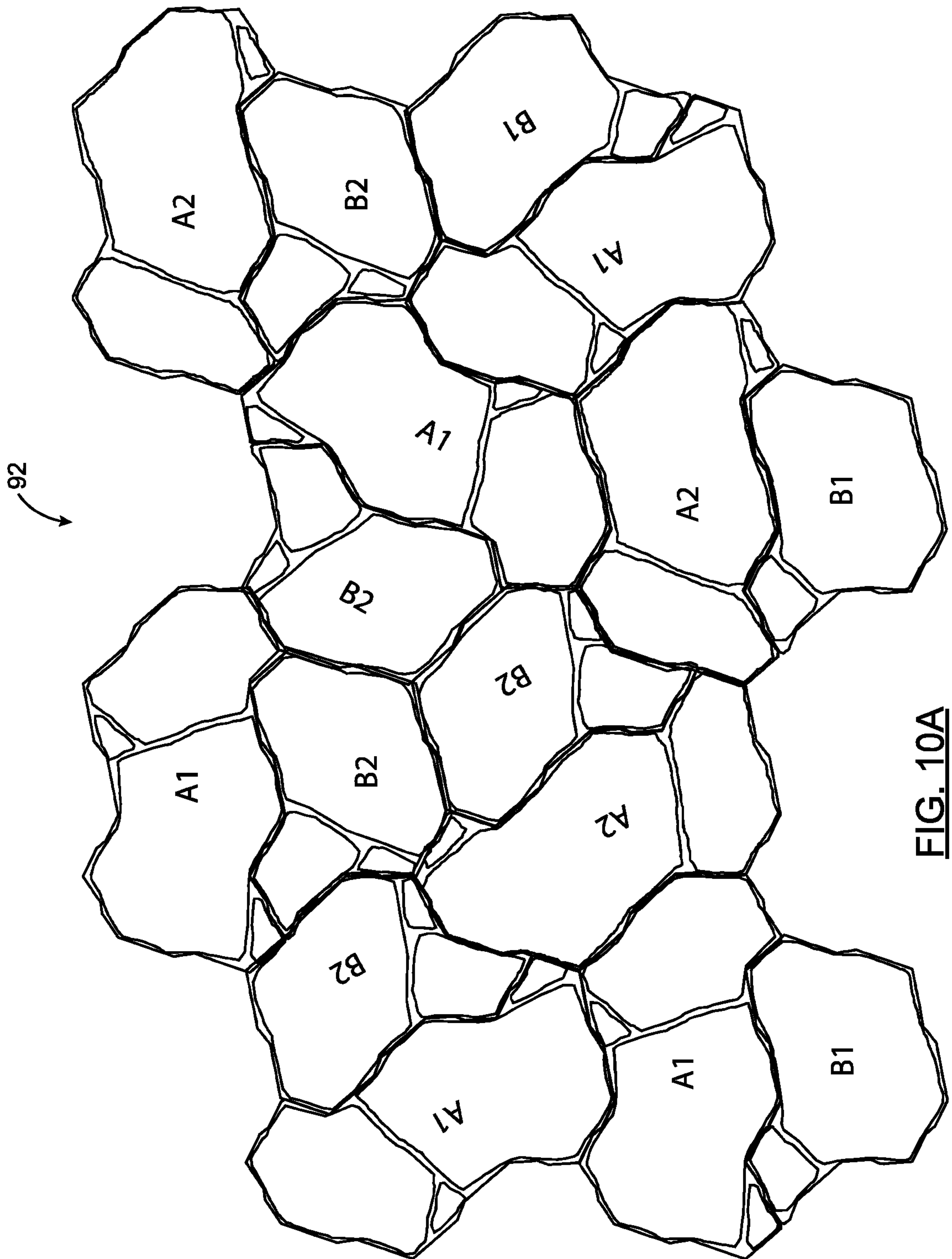


**FIG. 8**

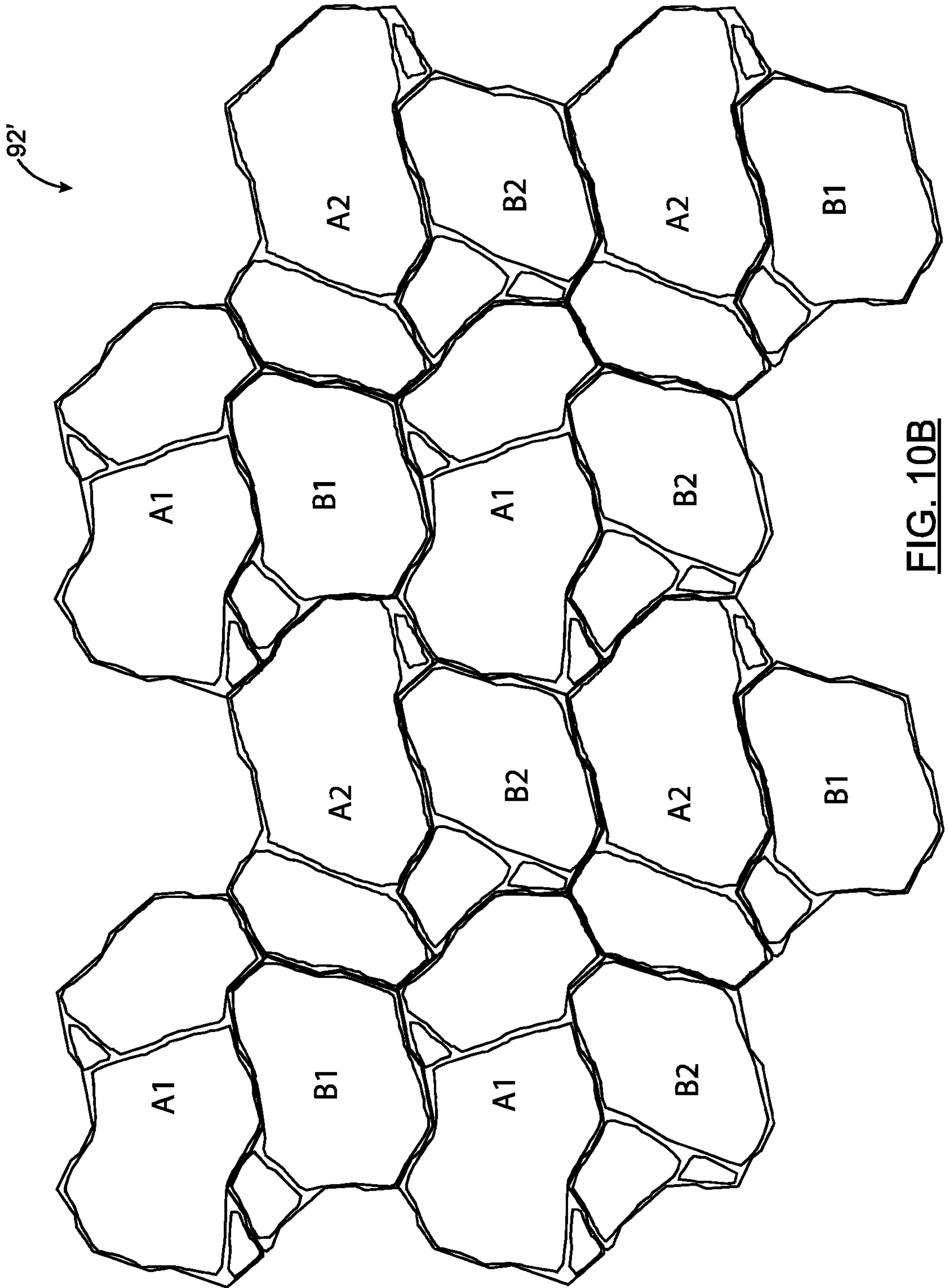
10/15



**FIG. 9**



**FIG. 10A**



**FIG. 10B**

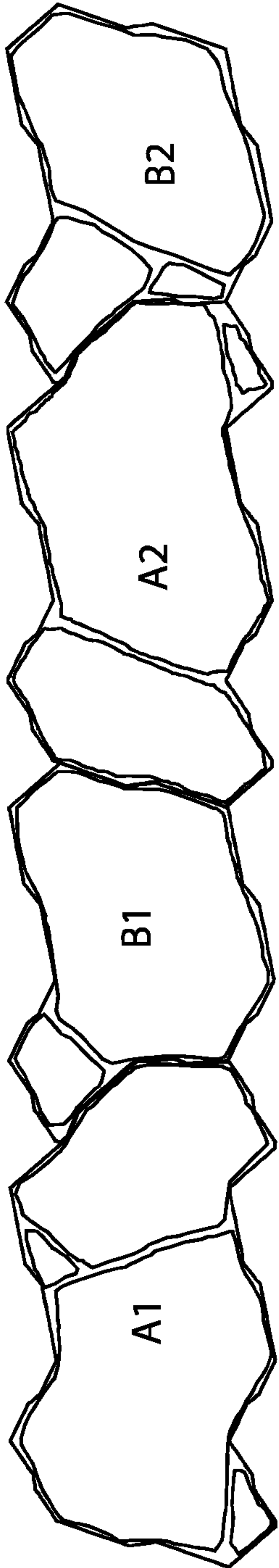


FIG. 11

13/15

94

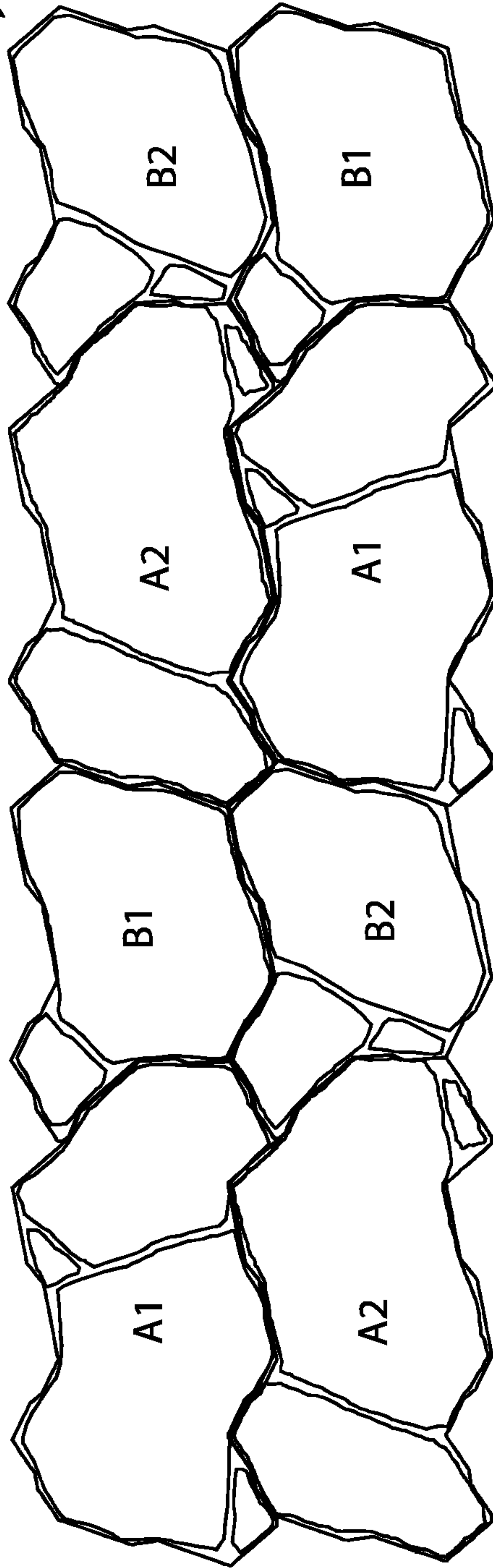
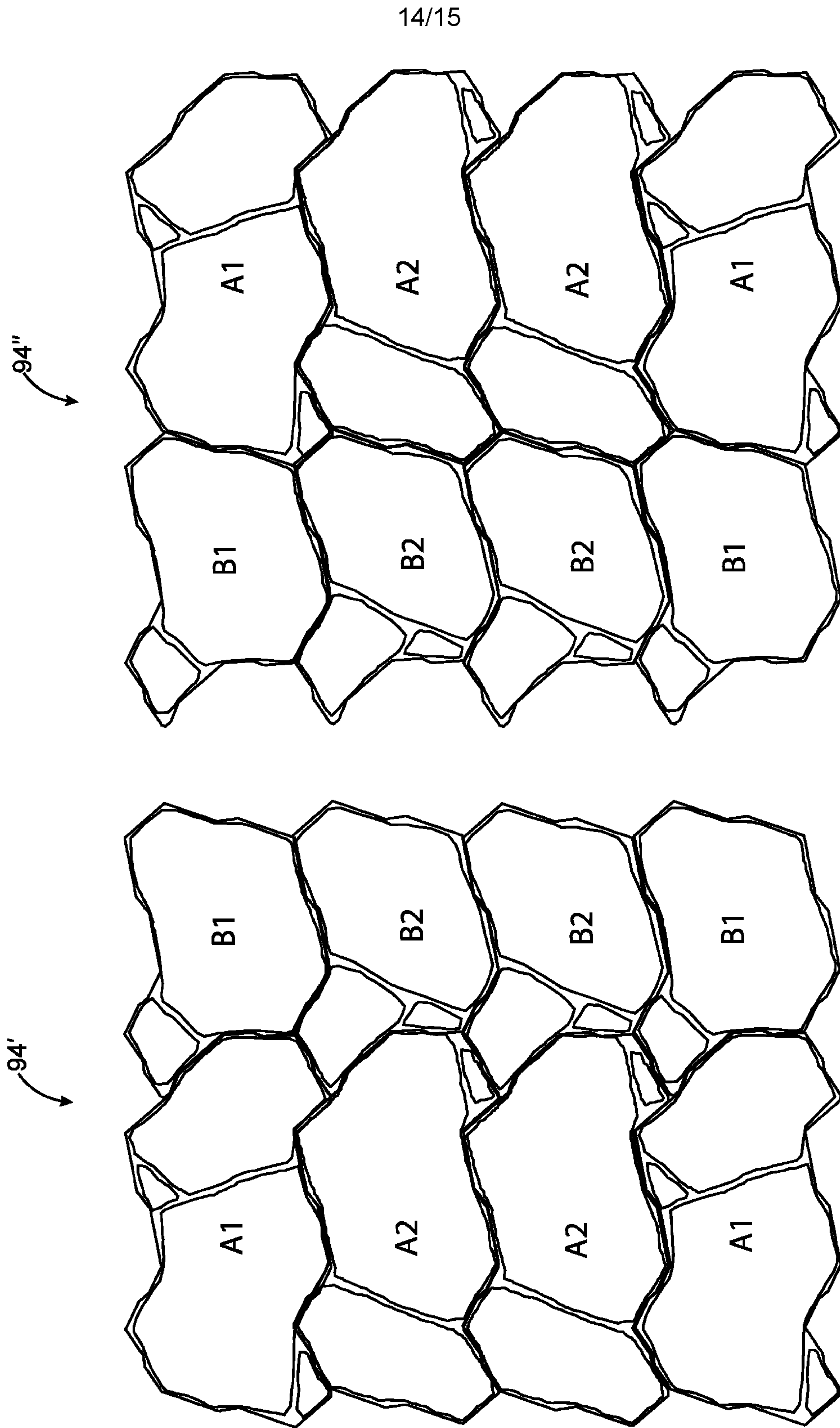


FIG. 12



**FIG. 13**

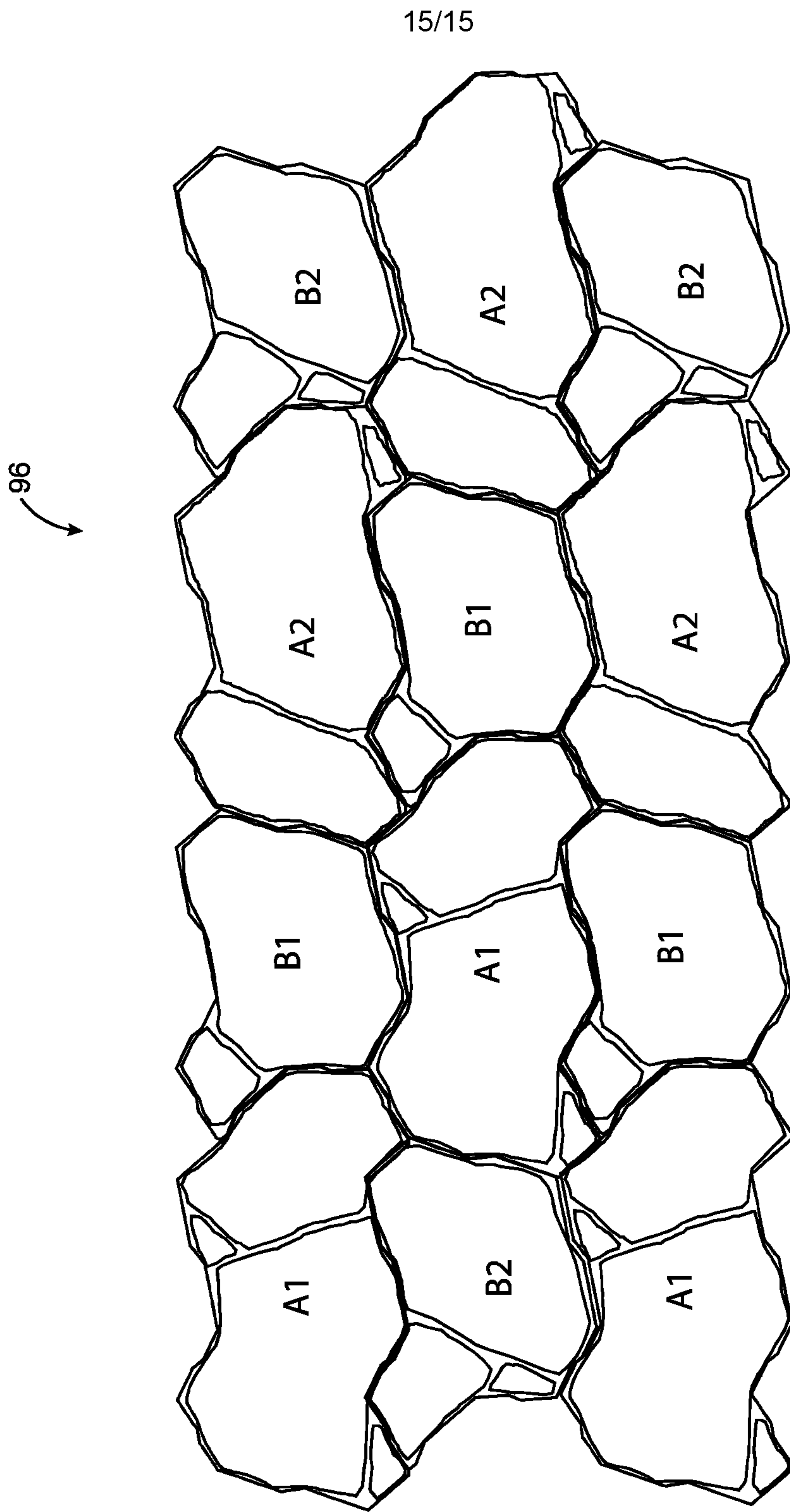


FIG. 14

