

(No Model.)

2 Sheets—Sheet 1.

L. SCHMEITZ.
DOOR HANGER.

No. 425,524.

Patented Apr. 15, 1890.

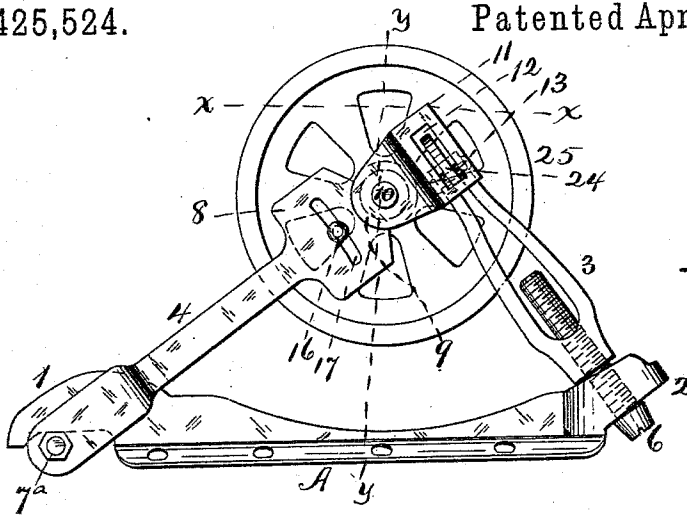

Fig-1

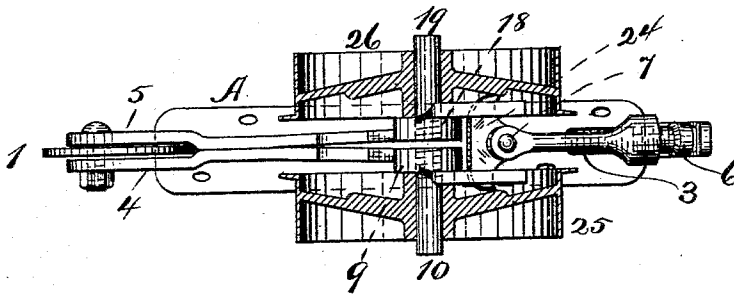

Fig-2

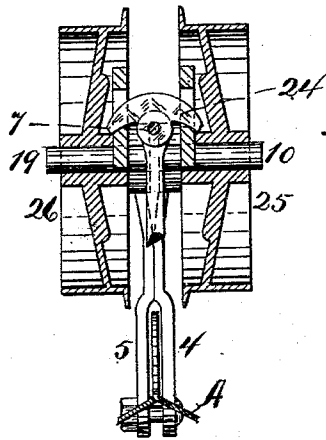

Fig-3.

Witnesses

A. P. Devison

W. M. Devison

Leonard Schmeitz Inventor

By his Attorneys
Smith & Devison

(No Model.)

2 Sheets—Sheet 2.

L. SCHMEITZ.
DOOR HANGER.

No. 425,524.

Patented Apr. 15, 1890.

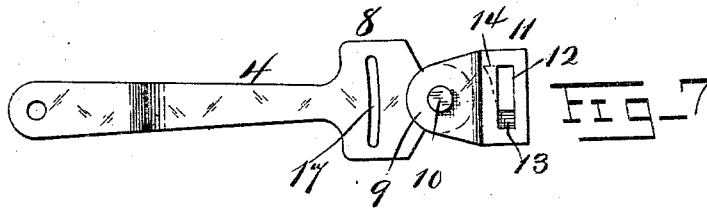
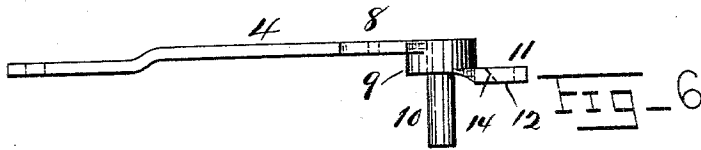
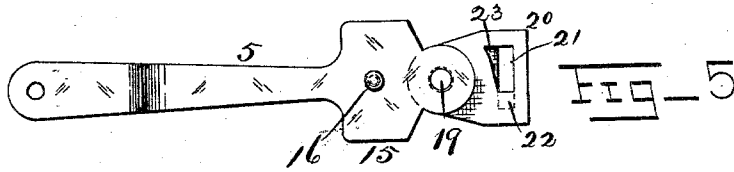
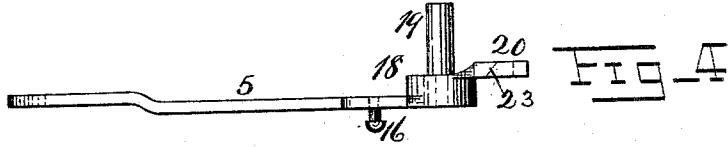

Witnesses

H. P. Demson

H. P. Demson

Leonard Schmeitz Inventor

By his Attorneys
Smith & Demison

UNITED STATES PATENT OFFICE.

LEONARD SCHMEITZ, OF SYRACUSE, NEW YORK.

DOOR-HANGER.

SPECIFICATION forming part of Letters Patent No. 425,524, dated April 15, 1890.

Application filed June 15, 1889. Serial No. 314,431. (No model.)

To all whom it may concern:

Be it known that I, LEONARD SCHMEITZ, of Syracuse, county of Onondaga, in the State of New York, a citizen of the United States, have invented certain new and useful Improvements in Door - Hangers, of which the following is a specification, reference being had to the accompanying drawings, in which—

Figure 1 is a side elevation of the hanger complete. Fig. 2 is a horizontal section on the line *xx*. Fig. 3 is a vertical section on the line *yy*. Fig. 4 is a side elevation of a suspension-rod. Fig. 5 is a plan view of the same. Fig. 6 is a side elevation of the other suspension-bar. Fig. 7 is a plan view thereof. Fig. 8 is a plan view of the rocker in the upper end of the suspension-rod and connecting it to the suspension-bars by a pivotal connection.

My invention relates to door-hangers which comprise a stationary overhead trackway, a carriage-frame, and wheels or rollers journaled in or upon the frame and traveling upon the trackway, the frame being connected to the top of the door.

My object is to more perfectly adapt the hanger to travel upon a rough, uneven, or warped trackway and to simplify the construction and to permit the wheels on one side of the carriage to travel in a different plane horizontally from the plane of the other by means of a pivotal connection between the suspension-rods.

My invention consists in the several novel features of construction and operation hereinafter described, and which are hereinafter set forth in the claim hereto annexed.

It is constructed as follows: A is the base-plate, adapted to be secured to the top of the door, and provided on one end with a hook 1 and on the other with a perforated or slotted boss 2. The carriage-frame is composed of the suspension bars or rods 3, 4, and 5. The bar 3 is composed of a body of tubular form and threaded internally to receive the screw 6 and arms branching out from the body and perforated in their outer ends to receive the screw or rivet 7, and the screw 6, passing through the boss 2, makes this bar adjustable with reference to the base-plate. The bar 4

is offset at its lower end and perforated transversely, and toward its upper end is provided with a slotted enlargement 8 and beyond that with a boss 9, and 10 is an arbor projecting outwardly from the boss, and 11 is a flat lip or plate integral with the boss, and it is provided with a slotway 12, and the edges of this slotway are beveled, as at 13 and 14. The bar 5 is offset at its lower end and perforated like the bar 4, and is provided with an enlargement 15, like or substantially like unto 8, and with a stud 16, which fits loosely in the slotway 17 (in 8) when the bars, 3, 4, and 5 are placed together, forming a Y at their lower ends, and a securing-bolt 7^a is inserted through these ends, fitting loosely therein, and 18 is a boss like unto 9 above the enlargement 15, and 19 is an arbor vertically central to the boss, and 20 is a flat projection beyond the boss, which is slotted at 21, and this slot is beveled, as at 22 and 23. When the bars 4 and 5 are placed together with the stud 16 in the slot 17, the arbors 10 and 19 stand outwardly and horizontal and the plates 11 and 20 are opposite each other.

I mount the rocker 24 upon the screw 7, between the arms of the bar 3, pivotally, and the arms of this rocker fit on either side into the slots 12 and 21, respectively. This creates a rocking connection at the apex of the suspension-bars, permitting either of the sections 4 or 5 to rise or fall independent of the other, and as these bars carry the wheels 25 and 26 upon the arbors 10 and 19 either wheel can and will follow the face of its trackway. When, for instance, the wheel 25 encounters an inequality in its track, raising it, the bar 4 rises freely at its upper end on account of its pivotal connection to the lower end of the bar 5 and the slot-and-pin connection 16 17, and the wheel will follow the face or surface of the track, that side of the rocker being elevated or depressed, the point sliding or swinging upon its pivotal connection around in the slot 21, the bevels 22 or 23 preventing it from binding in the slot.

What I claim as my invention, and desire to secure by Letters Patent, is—

A door-hanger consisting of a door-piece provided with a hook upon one end and a

boss to receive the adjusting-screw upon the
other end, suspension - bars pivotally con-
nected around the hook at one end and hav-
ing a slot-and-pin connection adjacent to the
5 upper end, and having the wheel-arbors inte-
gral therewith and provided with slotted ex-
tensions above the wheel-arbors, and a forked
suspension-rod receiving the adjusting-screw
at one end, and having a rocker pivotally
10 mounted between the arms upon the other

end, the points of the rocker fitting in the
slotways in the extension-bars, substantially
as described.

In witness whereof I have hereunto set my
hand this 1st day of October, 1888.

LEONARD SCHMEITZ.

In presence of—
HOWARD P. DENISON,
C. W. SMITH.