

March 12, 1935.

A. FRISCO  
HOSE NOZZLE

1,994,389

Filed July 24, 1934

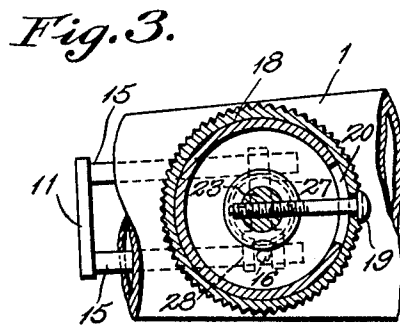
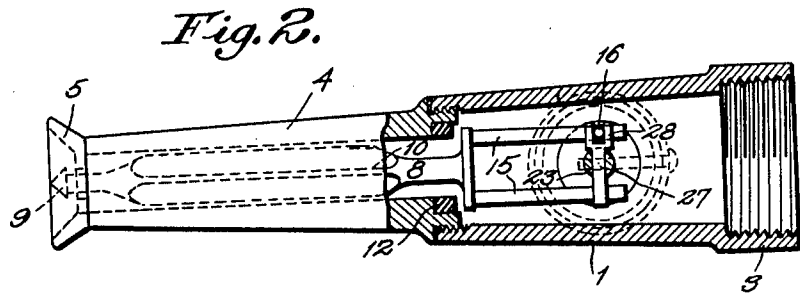
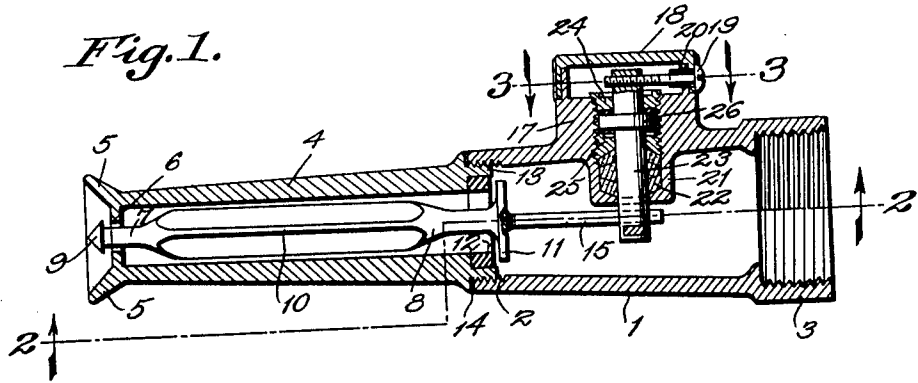

Andrew Frisco  
INVENTOR  
BY Victor J. Evans & Co.  
ATTORNEY

*R. E. Wise.*

WITNESS:

Patented Mar. 12, 1935

1,994,389

# UNITED STATES PATENT OFFICE

1,994,389

## HOSE NOZZLE

Andrew Frisco, Akron, Ohio

Application July 24, 1934, Serial No. 736,738

2 Claims. (Cl. 299—131)

This invention relates to hose nozzles and its general object is to provide a nozzle that can be adjusted from completely opened to closed positions to vary the stream as desired, in an easy and expeditious manner and with the same hand used to hold the nozzle.

A further object of the invention is to provide a nozzle of the character set forth, that is leak proof, simple in construction, inexpensive to manufacture and extremely efficient in use and service.

This invention also consists in certain other features of construction and in the combination and arrangement of the several parts, to be hereinafter fully described, illustrated in the accompanying drawing and specifically pointed out in the appended claims.

In describing my invention in detail, reference will be had to the accompanying drawing wherein like characters denote like or corresponding parts throughout the several views, and in which:

Figure 1 is a longitudinal sectional view taken through the nozzle which forms the subject matter of the present invention.

Figure 2 is a sectional view taken approximately on line 2—2 of Figure 1, looking in the direction of the arrows.

Figure 3 is a sectional view taken approximately on line 3—3 of Figure 1, looking in the direction of the arrows.

Referring to the drawing in detail, the reference numeral 1 indicates the body of my nozzle which as shown is slightly tapered toward one end which is interiorly threaded as at 2, while its opposite end is in the form of a collar 3 that is likewise interiorly threaded for the purpose of being threadedly connected to the end of a hose or the like.

Threadedly secured to the threaded end 2 is the outlet portion 4 of my nozzle and which includes the usual outwardly flared mouth 5 having a partition 6 arranged at the juncture of the mouth 5 with the outlet portion as clearly shown in Figure 1, and this partition is provided with the usual centrally disposed opening for the passage of the reduced end 7 of the plunger 8, the latter having a spear head 9 formed on its outer end for disposal within the mouth 5.

The plunger or piston 8 may have formed longitudinally thereon vanes 10 and the inner end thereof has formed thereon a valve head 11 which extends into the body 1 and cooperates with an elastic washer 12 to control passage between the body and the outlet portion as shown. The washer is disposed within a shouldered portion pro-

vided by an exteriorly threaded collar 13 that acts to threadedly secure the outlet portion to the body, and a gasket 14 is employed to provide a leak proof connection between the outlet portion and the body, as will be apparent.

Extending rearwardly from the valve head 11 is a pair of parallel arranged arms 15 and one of these arms has secured thereto adjacent its free end and extending at right angles therefrom a pin 16 for a purpose which will be presently described.

The body has a boss 17 formed thereon and laterally extending therefrom, and the boss is provided with an annular flange to rotatably receive a cap 18 that is held associated therewith through the instrumentality of a screw 19 which is mounted for movement in a slot 20 arranged in the flange as best shown in Figure 3.

The boss is provided with a bore centrally arranged therein and extending inwardly from the boss is a hollow member 21 having a reduced inner end with an opening therein, and the hollow member provides a chamber for the purpose of receiving packing 22 for a shaft 23.

The bore of the boss is threaded for a portion of its length to receive gland members 24 and 25 which are disposed upon opposite sides of a collar 26 formed on the shaft as best shown in Figure 1 to hold the shaft associated within the bore and for rotation.

The gland members are preferably kerfed to receive a tool so that they can be readily associated and removed with respect to the bore, and of course it will be understood that the packing 22 prevents leakage about the shaft.

The upper end of the shaft has preferably arranged transversely therethrough a threaded bore to receive the screw 19 so that upon rotation of the cap the shaft will be rotated accordingly. The lower end of the shaft has extending therethrough the shank 27 of a fork member and the forked end which is indicated by the reference numeral 28 receives the pin 16, so that upon rotation of the shaft the plunger or piston 8 will be reciprocated through the instrumentality of the pin carrying arm 15 and the valve 10. The shank 27 is of a length to contact the other arm 15 as clearly shown in Figure 2.

From the above description and disclosure of the drawing, it will be obvious that I have provided a nozzle for a hose or the like that can be easily and expeditiously actuated from closed to open positions to vary the stream of fluid passing therethrough, and as the nozzle is actuated through the instrumentality of the cap 18 it can

be controlled by the same hand used to hold the nozzle. The velocity of the fluid is controlled by the valve which includes the head 11 while the spray is controlled by the head 9 and its relation with respect to the partition 6.

5 It is thought from the foregoing description that the advantages and novel features of my invention will be readily apparent.

10 I desire it to be understood that I may make changes in the construction and in the combination and arrangement of the several parts, provided that such changes fall within the scope of the appended claims.

What I claim is:

15 1. A nozzle comprising a body, an outlet portion threadedly secured to the body, a piston mounted for slidable movement longitudinally of the outlet portion, a valve head formed on the inner end of the piston and arranged in the body, means for cooperation with the valve head to control  
20 the passage of fluid from the body to the outlet portion, spray controlling means included in the piston and the outlet portion respectively, a shaft mounted for rotation through the body,

leak proof means for said shaft, means for rotating said shaft and means of connection between the shaft and the piston for actuating the latter.

2. A nozzle comprising a tapered body having a threaded end, an outlet portion secured to the threaded end and having an outwardly flared mouth, a piston mounted for reciprocation in the outlet portion and including vanes, valve means for controlling fluid from the body to the outlet portion and including a head mounted on the inner end of the piston, spray controlling means at the outer end of the outlet portion and including means formed on the piston, a boss formed on the body and having a bore extending therethrough for communication with the interior of the body, a shaft extending through the bore and mounted for rotation therein, leak proof means for the shaft, a cap mounted for rotation on the boss and connected with the shaft to actuate the same, and means extending from the piston and having connection with the shaft whereby the piston is actuated upon rotation of the cap.

ANDREW FRISCO.