

(12) STANDARD PATENT
(19) AUSTRALIAN PATENT OFFICE

(11) Application No. **AU 2016289982 B2**

(54) Title
Bucket for a construction vehicle used for loading, moving, transporting, pouring or spreading bulk material

(51) International Patent Classification(s)
E02F 3/352 (2006.01) **E02F 3/43** (2006.01)
E02F 3/36 (2006.01) **E02F 3/96** (2006.01)
E02F 3/407 (2006.01)

(21) Application No: **2016289982** (22) Date of Filing: **2016.06.10**

(87) WIPO No: **WO17/005999**

(30) Priority Data

(31) Number	(32) Date	(33) Country
1555333	2015.06.11	FR

(43) Publication Date: **2017.01.12**

(44) Accepted Journal Date: **2020.10.15**

(71) Applicant(s)
Abgrall Conception

(72) Inventor(s)
Abgrall, Roland;Abgrall, Pierrick;Abgrall, Philippe

(74) Agent / Attorney
Griffith Hack, Level 10 161 Collins St, MELBOURNE, VIC, 3000, AU

(56) Related Art
US 4055255 A
US 6662480 B1
JP H09125446 A

(12) DEMANDE INTERNATIONALE PUBLIÉE EN VERTU DU TRAITÉ DE COOPÉRATION EN MATIÈRE DE BREVETS (PCT)

(19) Organisation Mondiale de la
Propriété Intellectuelle
Bureau international



(43) Date de la publication internationale
12 janvier 2017 (12.01.2017)

WIPO | PCT

(10) Numéro de publication internationale
WO 2017/005999 A1

- (51) Classification internationale des brevets :
E02F 3/352 (2006.01) E02F 3/43 (2006.01)
E02F 3/36 (2006.01) E02F 3/96 (2006.01)
E02F 3/407 (2006.01)
- (21) Numéro de la demande internationale :
PCT/FR2016/051396
- (22) Date de dépôt international :
10 juin 2016 (10.06.2016)
- (25) Langue de dépôt : français
- (26) Langue de publication : français
- (30) Données relatives à la priorité :
1555333 11 juin 2015 (11.06.2015) FR
- (71) Déposant : ABGRALL ROGER ET FILS [FR/FR]; LD
Reun Ar Moal, 29460 Daoulas (FR).
- (72) Inventeurs : ABGRALL, Roland; Quénécadec, 29460
Logonna Daoulas (FR). ABGRALL, Pierrick; Le Rest
Pouligoo, 29460 Daoulas (FR). ABGRALL, Philippe; Lézuzan,
29460 Dirinon (FR).
- (74) Mandataire : DERRIENNIC, Tanguy; Ipside, 4, rue de
Kerogan, 29337 Quimper Cedex (FR).

- (81) États désignés (sauf indication contraire, pour tout titre de protection nationale disponible) : AE, AG, AL, AM, AO, AT, AU, AZ, BA, BB, BG, BH, BN, BR, BW, BY, BZ, CA, CH, CL, CN, CO, CR, CU, CZ, DE, DK, DM, DO, DZ, EC, EE, EG, ES, FI, GB, GD, GE, GH, GM, GT, HN, HR, HU, ID, IL, IN, IR, IS, JP, KE, KG, KN, KP, KR, KZ, LA, LC, LK, LR, LS, LU, LY, MA, MD, ME, MG, MK, MN, MW, MX, MY, MZ, NA, NG, NI, NO, NZ, OM, PA, PE, PG, PH, PL, PT, QA, RO, RS, RU, RW, SA, SC, SD, SE, SG, SK, SL, SM, ST, SV, SY, TH, TJ, TM, TN, TR, TT, TZ, UA, UG, US, UZ, VC, VN, ZA, ZM, ZW.
- (84) États désignés (sauf indication contraire, pour tout titre de protection régionale disponible) : ARIPO (BW, GH, GM, KE, LR, LS, MW, MZ, NA, RW, SD, SL, ST, SZ, TZ, UG, ZM, ZW), eurasiatique (AM, AZ, BY, KG, KZ, RU, TJ, TM), européen (AL, AT, BE, BG, CH, CY, CZ, DE, DK, EE, ES, FI, FR, GB, GR, HR, HU, IE, IS, IT, LT, LU, LV, MC, MK, MT, NL, NO, PL, PT, RO, RS, SE, SI, SK, SM, TR), OAPI (BF, BJ, CF, CG, CI, CM, GA, GN, GQ, GW, KM, ML, MR, NE, SN, TD, TG).

Déclarations en vertu de la règle 4.17 :

— relative à la qualité d'inventeur (règle 4.17.iv)

Publiée :

— avec rapport de recherche internationale (Art. 21(3))

(54) Title : BUCKET FOR A CONSTRUCTION VEHICLE USED FOR LOADING, MOVING, TRANSPORTING, POURING OR SPREADING BULK MATERIAL

(54) Titre : GODET POUR UN VÉHICULE DE TRAVAUX DESTINÉ À CHARGER, DÉPLACER, TRANSPORTER, DÉVERSER OU ÉPANDRE UN MATÉRIAU EN VRAC

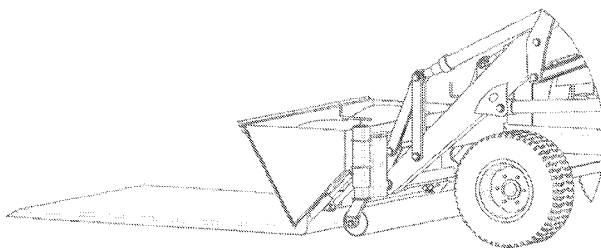

Fig. 6

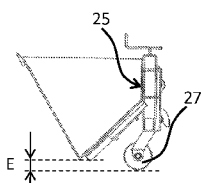

Fig. 11

(57) Abstract : The invention relates to a bucket for a construction vehicle used for loading, moving, transporting, pouring and spreading bulk material; said bucket comprises two lateral panels (20) extending on each side of a loading panel (21), the loading panel (21) being provided with a loading edge (211) and an unloading edge (212). The bucket also comprises: - a support panel (22); - an opening panel (23); - the adjustment system (25) comprises a rotatable roll (27) that is located behind the bucket and can rotate in the direction in which the vehicle wheels rotate and rest on the ground during the spreading operation.

(57) Abrégé : L'invention concerne un godet pour un véhicule de travaux destiné à charger, déplacer, transporter, déverser et épandre un matériau en vrac, le godet comporte deux panneaux latéraux (20) s'étendant de chaque côté d'un panneau de chargement (21), ledit panneau de chargement (21) comporte un bord de chargement (211) et un bord de déchargement (212). Le godet comporte également: un panneau de support (22), un panneau d'ouverture (23), le système de réglage (25) comporte un rouleau (27) mobile en rotation situé à l'arrière du godet et adapté à tourner dans le sens de rotation des roues du véhicule et à reposer sur le sol pendant l'épandage,



WO 2017/005999 A1

BUCKET FOR A CONSTRUCTION VEHICLE USED FOR LOADING,
MOVING, TRANSPORTING, POURING OR SPREADING BULK MATERIAL

TECHNICAL FIELD

5 The present invention relates to a bucket fitted to a vehicle intended to move, transport, tip a bulk material and spread it over a chosen thickness.

 Spreading is defined as being spreading out a product or material over the ground, dispersing it.

10 BACKGROUND

 The use of a spreading-out operation requires a special-purpose machine which is awkward to maneuver.

 Another way of achieving spreading is to do it by hand using manual labor. In that case, the work still remains very difficult because the loads to be
15 moved around are heavy and repetitive.

 Document FR2779456 describes a grader blade fitted to a vehicle and intended for the handling of bulk materials. However, that device is not designed to adjust the thickness of the spreading.

 Document US4055255 describes an industrial vehicle comprising a
20 bucket. The bucket makes it possible to choose the quantity of bulk material to be tipped out, but the bucket disclosed is not in any way designed to regulate the thickness of the layer of material during the spreading phase.

 The present invention seeks to overcome these disadvantages.

25 SUMMARY

 According to a first aspect, the present invention provides a bucket for an industrial vehicle intended to load, move, transport, tip and spread a bulk material; the bucket comprising two lateral panels extending on each side of a loading panel, the loading panel comprising a loading edge and an unloading
30 edge, wherein the bucket further comprises:

- a support panel for supporting an adjusting system designed to adjust the thickness of the layer of bulk material to be spread on the ground, the support panel being situated on the other side of the bucket from the loading panel;

- 5 - an opening panel comprising a gate comprising an opening edge, when the gate is in a closed position the opening edge is adjacent to the unloading edge of the loading panel to hold back the bulk material, whilst when the gate is in an open position, the opening edge is moved away from the unloading edge of the loading panel to create an opening intended to allow the bulk material to pour out;
- 10 - the adjusting system comprising a roller capable of rotational movement situated under the bucket and designed to turn in the direction of rotation of the wheels of the vehicle and to rest on the ground during spreading; and
- 15 - a fixing attachment designed to be fixed to the vehicle, the fixing attachment being housed in a space capable of vertical translational movement configured to leave travel for vertical translational movement and the fixing attachment being capable of rotational movement about an axis of rotation perpendicular to the support panel so as to turn the bucket relative to the ground.

Thanks to these measures, the bucket has several functions: loading, moving, transporting, tipping out a bulk material or spreading same over a chosen thickness.

20 Thus, the thickness of the bulk material tipped out during the spreading phase is kept fixed using a roller irrespective of the unevennesses of ground encountered.

The fixing attachment is a floating attachment and adapts to the terrain to ensure the same thickness of bulk material during spreading. The bucket is 25 able to follow the contour of the route. The bucket perfectly follows the support and can be fitted to all types of loader (loading shovel, tractor shovel, telescopic loader, tractor loader, etc.).

The bucket makes it possible to:

- 30 - enormously relieve the workload on individuals (less handling: wheelbarrows and floats),
- save production time (speed of spreading),
- control the thickness of the spreading,
- provide a manual finish (no difference between hand and machine, no visible joins between passes) as with a finisher for creating a coated surface.

Other advantages:

- simple to use,
- little wear (no gearing).

5 In one embodiment, the vertical travel of the fixing attachment may be between 0.5 and 50 cm. The vertical travel of the fixing attachment may be between 1 and 15 cm.

In one embodiment, said roller may be capable of vertical translational movement relative to the ground so as to vary the height of the bucket relative to the ground. Thus, the spreading thickness can be chosen.

10 In one embodiment, the gate may be capable of rectilinear translational movement supported on guideways on each side of the gate, the rectilinear translational movement being actuated by actuating cylinders.

In one embodiment, the length of the roller may be at least equal to half the length of the bucket.

15 In one embodiment, the bucket may comprise a plurality of gates capable of rectilinear translational movement.

Thus, the bucket can tip a certain quantity of bulk material out on just one side or the other. In addition, the act of opening over a certain length makes it possible to vary the width of the strip of bulk material to be spread.

20 Another advantage is, for example, that of opening a gate over a wheelbarrow and of being able to tip bulk material out to fill the wheelbarrow.

In one embodiment, the bucket may comprise a surface that reduces the opening created by the opening panel in the open position. The surface may be capable of translational movement by means of an adjusting element that
25 adjusts the position of the surface relative to the opening created by the opening panel in the open position.

According to a second aspect, the invention also provides a vehicle equipped with a bucket as described herein.

30 BRIEF DESCRIPTION OF THE FIGURES

Further advantages, aspects and features of the present invention will become apparent from the following description given by way of entirely nonlimiting explanation with reference to the attached drawings in which:

- figures 1 and 2 depict a diagram of the loading of bulk material into the bucket that forms the subject of the present invention,

- figures 3 and 4 depict a diagram of the tipping of a bulk material out from the bucket that forms the subject of the present invention,

5 - figures 5 and 6 depict a diagram of the spreading of a bulk material using the bucket placed on the ground, which is the subject of the present invention,

- figure 7 depicts a rear view of the bucket according to one embodiment,

10 - figure 8 depicts an exploded view of the bucket according to one embodiment,

- figure 9 depicts a perspective view of a bucket according to one embodiment,

15 - figure 10 depicts another perspective view of a bucket according to another embodiment,

- figure 11 depicts a side view of the bucket according to one embodiment,

- figure 12 depicts a rear view of the bucket to show the attachment according to one embodiment,

20 - figure 13 depicts a perspective view of the bucket mounted on a vehicle according to one embodiment.

DESCRIPTION OF THE EMBODIMENTS OF THE INVENTION

25 Figures 1 and 2 depict perspective diagrams of the loading of a bulk material into the bucket. These two figures show the step of loading the bulk material from two different viewpoints.

The loading can be various types of material:

- 30
- all grades of gravel 0/20, 0/31.5, etc.
 - sand (stabilized),
 - chippings,
 - cement concrete (depending on the water content),
 - asphalt concrete (coated),
 - etc.

The bucket is used to load the bulk material from a heap. In another embodiment, the bucket is used to collect a bulk material under the dump gate of a truck.

5 Figures 3 and 4 depict a diagram of the tipping of a bulk material out of the bucket. These two figures show a step in the tipping-out of the bulk material, from two different viewpoints.

In this case, the opening gate allows the bulk material to be released and to pour out.

10 Figures 5 and 6 depict a diagram of the spreading of a bulk material using the bucket that forms the subject of the present invention. These two figures show a step of spreading the bulk material from two different viewpoints.

More particularly, figure 6 shows the roller adjusted in such a way that the bottom of the bucket is held a certain distance off the ground. In this way, the roller dictates the thickness of the bulk material. Adjusting this distance
15 regulates the thickness of the layer of material distributed after the spreading phase.

The material leaves the bucket via the opening gate which releases the bulk material under the effect of gravity.

20 Figure 7 depicts the bucket on which the cranks 26 are mounted. Shown here are the adjusting system 25, the roller 27 and the support panel 22.

Figure 8 depicts an exploded view of a bucket. Shown here are two lateral panels 20 extending on each side of a loading panel 21, the support panel 22 to which the adjusting system 25 with the roller 27 and the cranks 26 is fixed. Also shown is the opening panel 23 comprising a gate 24.

25 The loading panel 21 has four edges, two edges connecting the lateral panels 20, a loading edge 211 delimiting part of the main opening of the bucket, an unloading edge 212 delimiting part of a secondary opening. The unloading edge is on the other side of the panel from the loading edge 211. The secondary opening is controlled by the opening of the gate 24 on the opening
30 panel 23.

Figures 9 and 10 depict two alternative forms of bucket with two different types of fixing attachment 28 for a type of vehicle. The two attachments both have the same functionalities but differ only in terms of the system for fixing to the vehicle. The attachment is produced in such a way that

it fits the chosen vehicle while at the same time maintaining the rotation and translation so that the attachment is floating relative to the ground.

Figure 11 depicts a side view of the bucket. A roller connected to the adjusting system 25 can be seen. The roller 27 is made of steel and situated to the rear of the bucket. When the bucket is in the spreading position, the roller 27 rests on the ground.

The adjusting system 25 comprises two hand cranks (one on each side of the bucket), this is adjustable heightwise and thus makes it possible to choose the thickness E to be spread. The ground is depicted in dotted line and the difference between the bottom of the bucket and the ground is indicated by the reference E.

In one embodiment, the thickness differs from one side to the other.

The roller 27 has the advantage of having a bearing surface over the entire length of the bucket, thus avoiding under thicknesses.

Figure 12 depicts a rear view of the bucket. It shows a fixing attachment 28 on which the position of the fixing attachment 28 is over-inclined relative to the bucket. Specifically, the fixing attachment 28 has transverse mobility (arrow A) relative to the support panel 22.

The fixing attachment 28 also has the ability to move about an axis of rotation 29 relative to the ground (arrow B). The axis of rotation is perpendicular to the support panel 22.

Figure 13 depicts a perspective view of the bucket mounted on a vehicle according to one embodiment.

In an alternative form of embodiment, the mobile roller 27 is replaced by a caterpillar track system.

In one embodiment, the width of the bucket is 2 m. It is comprised between 1 and 3.5 m.

In another embodiment, the bucket comprises several opening gates making it possible to vary the spreading width.

In another embodiment, the opening gate comprises a guideway system to slide the gate from left to right, thus varying the spreading width.

The diameter of the roller is 20 cm. It is comprised between 10 and 50 cm.

In another alternative form which has not been depicted, the bucket comprises a plate positioned above the bucket leaving a width of opening that can be varied between 0.5 and 5 cm so that the chippings can be spread by inclining the bucket.

5 It is to be understood that, if any prior art publication is referred to herein, such reference does not constitute an admission that the publication forms a part of the common general knowledge in the art, in Australia or any other country.

10 In the claims which follow and in the preceding description of the invention, except where the context requires otherwise due to express language or necessary implication, the word "comprise" or variations such as "comprises" or "comprising" is used in an inclusive sense, i.e. to specify the presence of the stated features but not to preclude the presence or addition of further features in various embodiments of the invention.

15

LIST OF PARTS

- 20 lateral panels
- 21 loading panel
- 5 211 loading edge
- 212 unloading edge
- 22 support panel
- 23 opening panel
- 24 gate
- 10 25 adjusting system
- 26 cranks
- 27 roller
- 28 fixing attachment for fixing to a vehicle
- 29 axis of rotation
- 15
- E adjustable thickness
- A translation arrow
- B rotation arrow

CLAIMS

1. A bucket for an industrial vehicle intended to load, move, transport, tip and spread a bulk material; the bucket comprising two lateral panels extending on each side of a loading panel, the loading panel comprising a loading edge and an unloading edge; wherein the bucket further comprises:
- 5 - a support panel for supporting an adjusting system designed to adjust the thickness of the layer of bulk material to be spread on the ground, the support panel being situated on the other side of the bucket from the loading panel;
- 10 - an opening panel comprising a gate comprising an opening edge, when the gate is in a closed position the opening edge is adjacent to the unloading edge of the loading panel to hold back the bulk material, whilst when the gate is in an open position the opening edge is moved away from the unloading edge of the loading panel to create an opening intended to allow the bulk material to pour out,
- 15 - the adjusting system comprising a roller capable of rotational movement situated under the bucket and designed to turn in the direction of rotation of the wheels of the vehicle and to rest on the ground during spreading; and
- 20 - a fixing attachment designed to be fixed to the vehicle, the fixing attachment being housed in a space capable of vertical translational movement configured to leave travel for vertical translational movement and the fixing attachment being capable of rotational movement about an axis of rotation perpendicular to the support panel so as to turn the bucket relative to the ground.
- 25
2. The bucket as claimed in claim 1, wherein the vertical travel of the fixing attachment is between 0.5 and 50 cm.
3. The bucket as claimed in claim 2, wherein the vertical travel of the fixing
- 30 attachment is between 1 and 15 cm.

4. The bucket as claimed in any one of claims 1 to 3, wherein the roller is capable of vertical translational movement relative to the ground so as to vary the height of the bucket relative to the ground.
- 5 5. The bucket as claimed in any one of claims 1 to 4, wherein the gate is capable of rectilinear translational movement supported on guideways on each side of the gate, the rectilinear translational movement being actuated by actuating cylinders.
- 10 6. The bucket as claimed in any one of claims 1 to 5, in which the length of the roller is at least equal to half the length of the bucket.
7. The bucket as claimed in any one of claims 1 to 6, in which the bucket comprises a plurality of gates capable of rectilinear translational movement.
- 15 8. The bucket as claimed in one of claims 1 to 7, further comprising a surface that reduces the opening created by the opening panel in the open position.
- 20 9. The bucket as claimed in claim 8, in which the surface is capable of translational movement through an adjusting element that adjusts the position of the surface relative to the opening created by the opening panel in the open position.
- 25 10. A vehicle equipped with a bucket as claimed in one of claims 1 to 9.

1 / 5

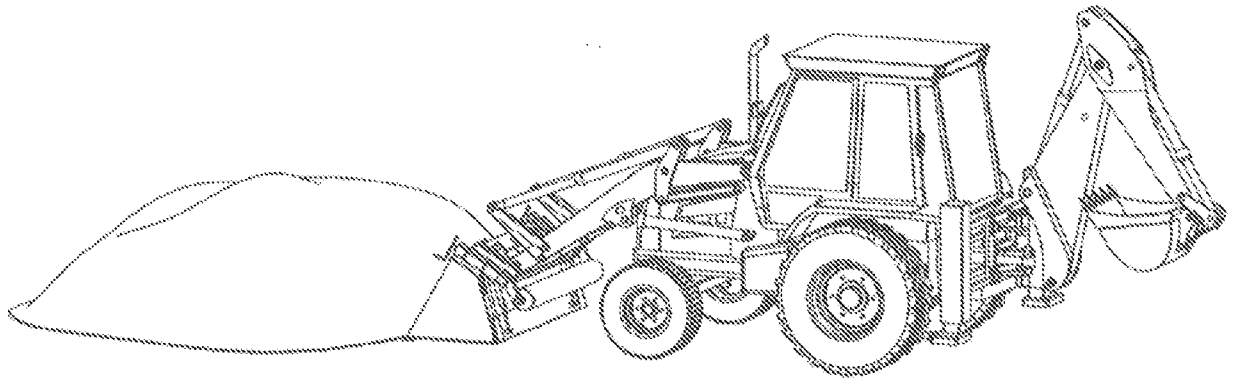

Fig. 1

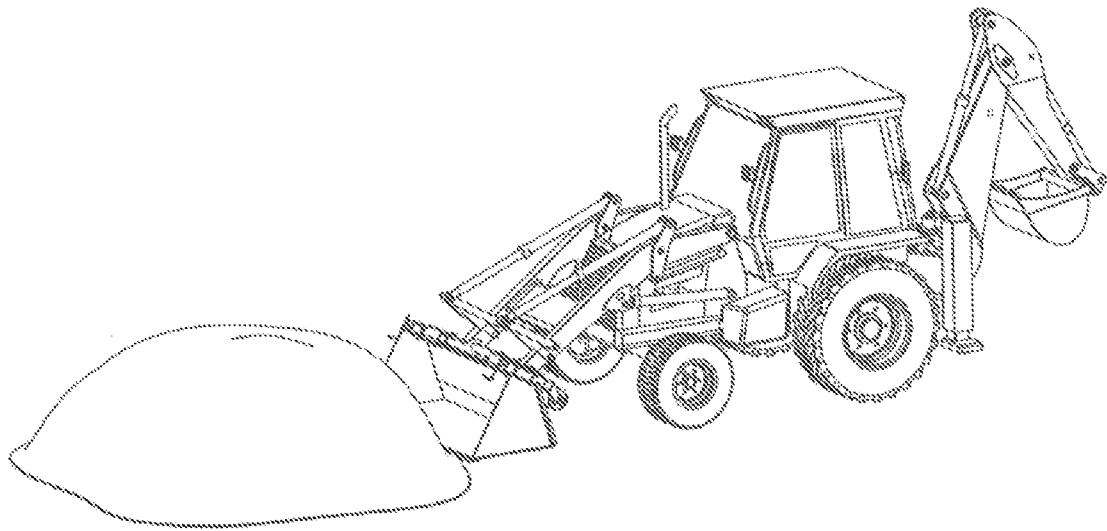

Fig. 2

2 / 5

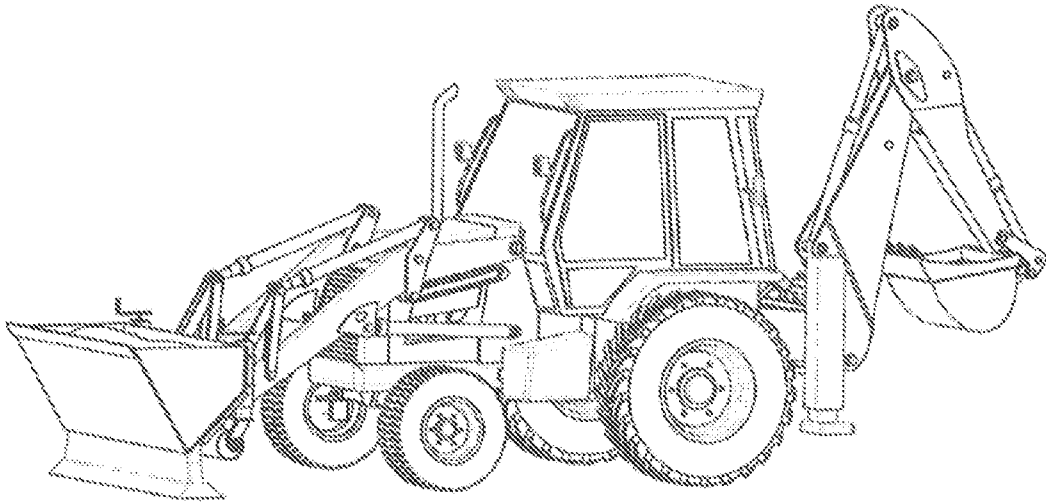

Fig. 3

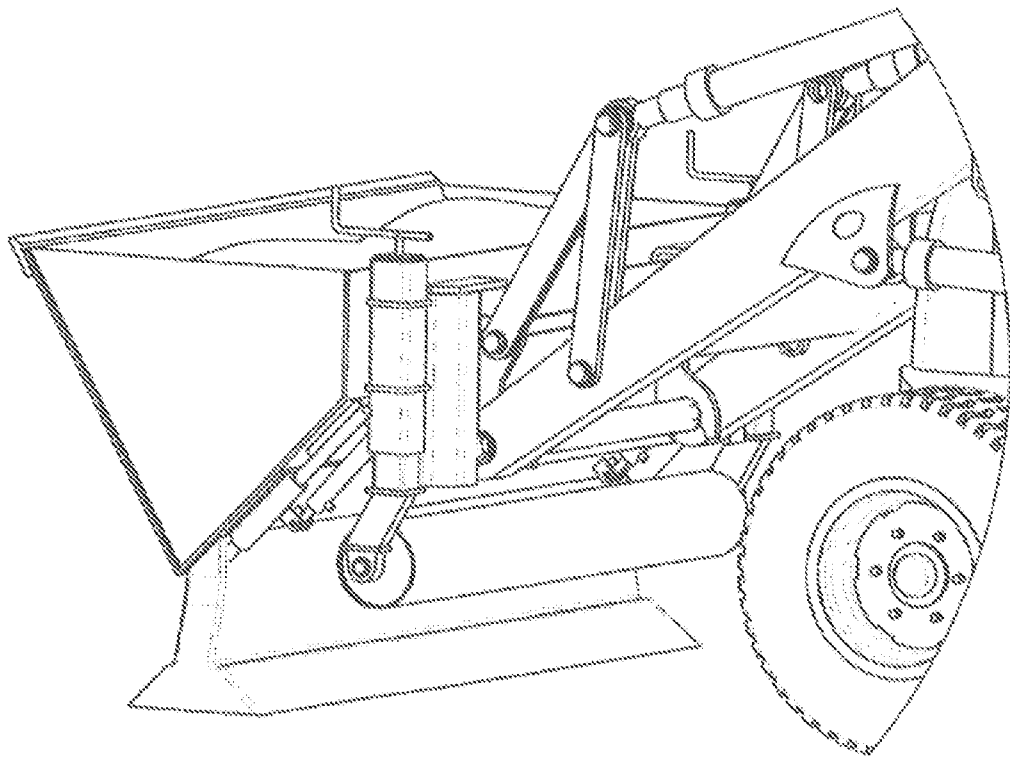

Fig. 4

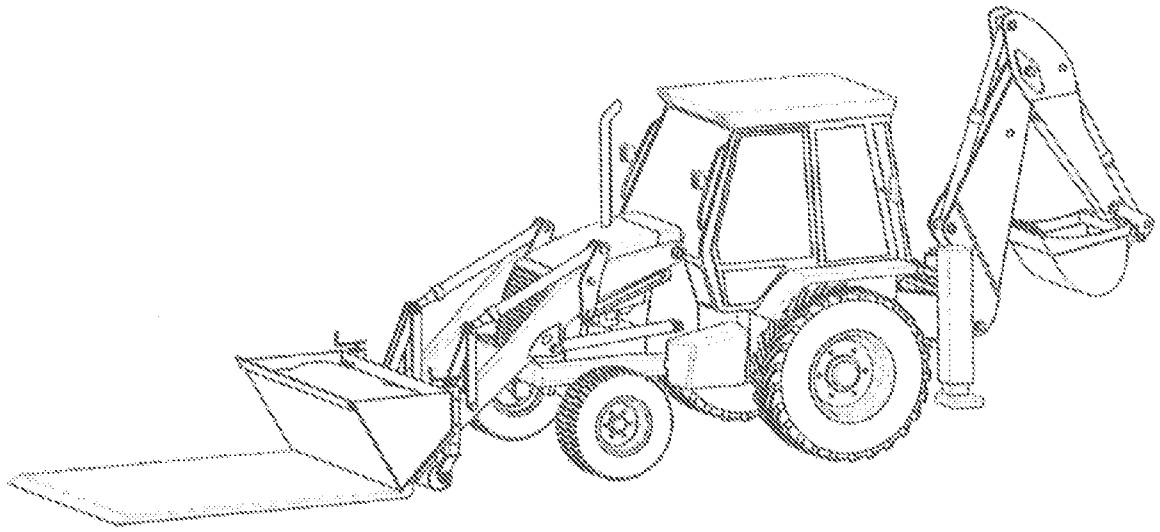

Fig. 5

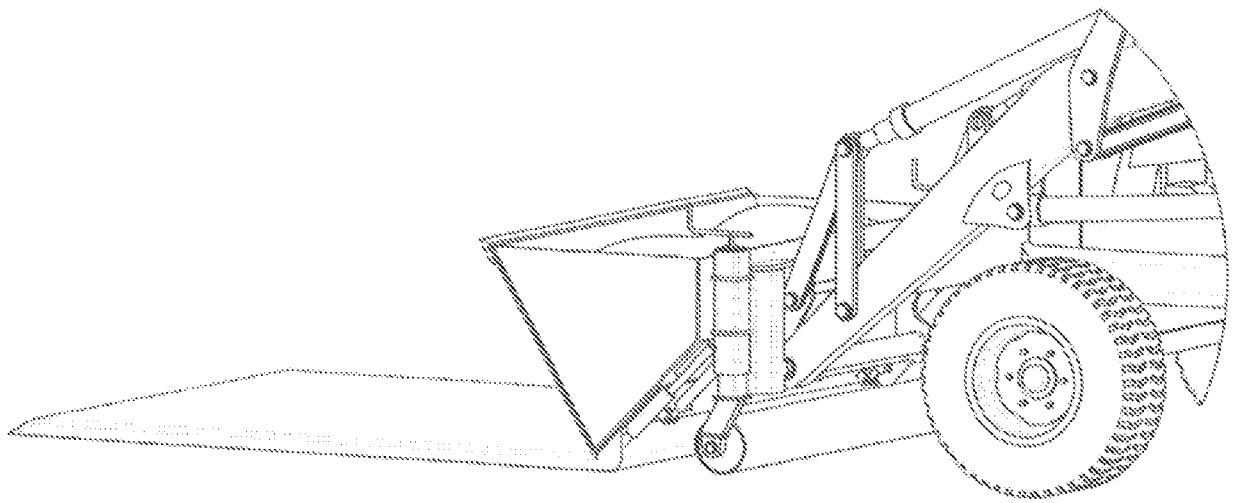

Fig. 6

4 / 5

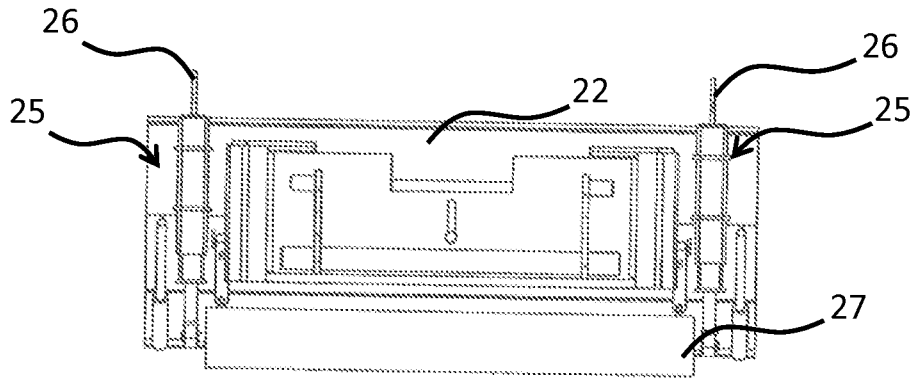

Fig. 7

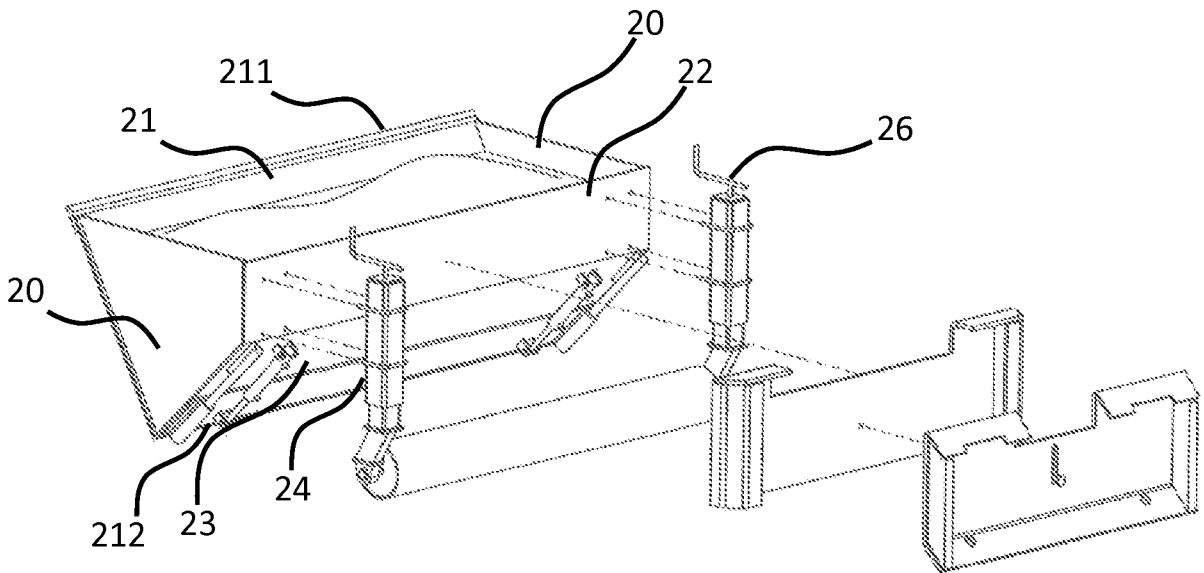

Fig. 8

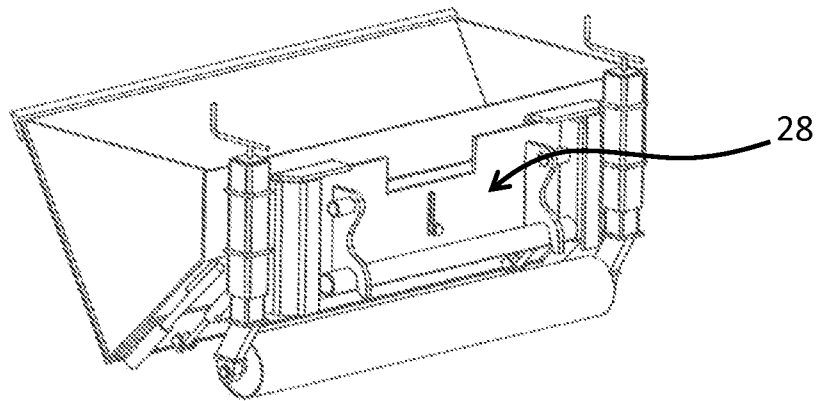

Fig. 9

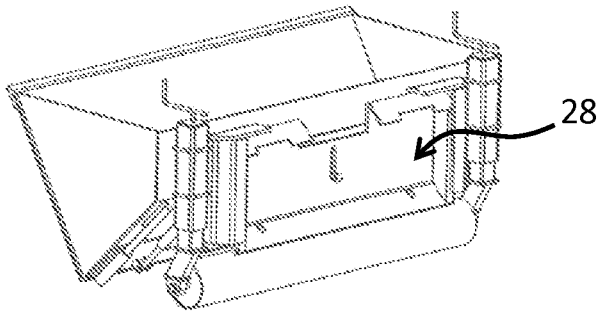

Fig. 10

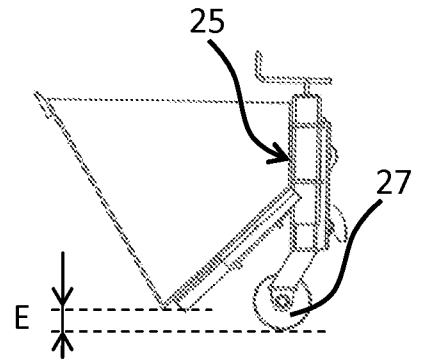

Fig. 11

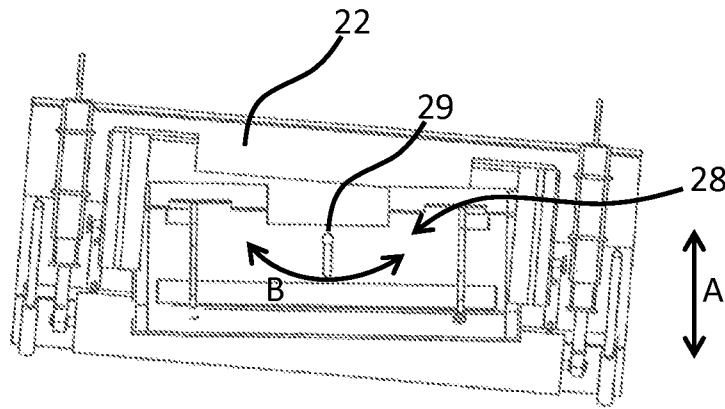

Fig. 12

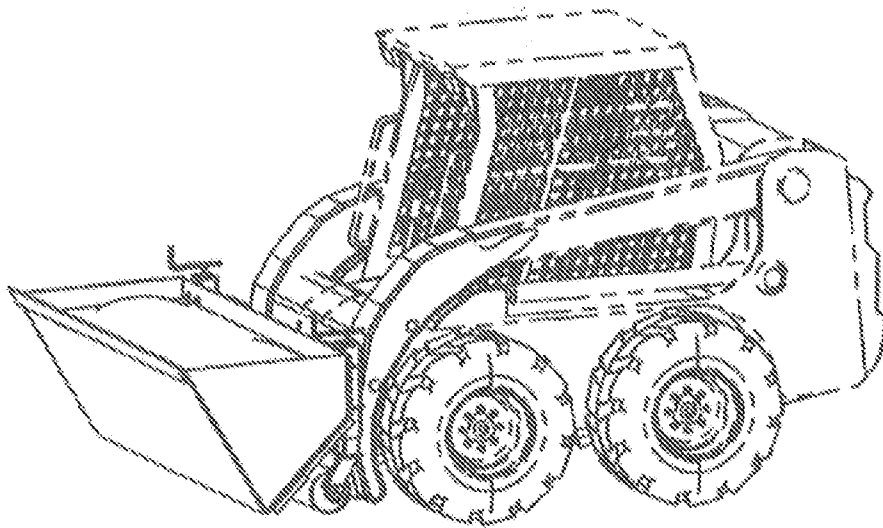

Fig. 13