

W. H. LEE.

MEANS FOR TILTING THE EARTH TURNING ELEMENTS OF WHEELED PLOWS.

APPLICATION FILED FEB. 8, 1909.

1,069,340.

Patented Aug. 5, 1913.

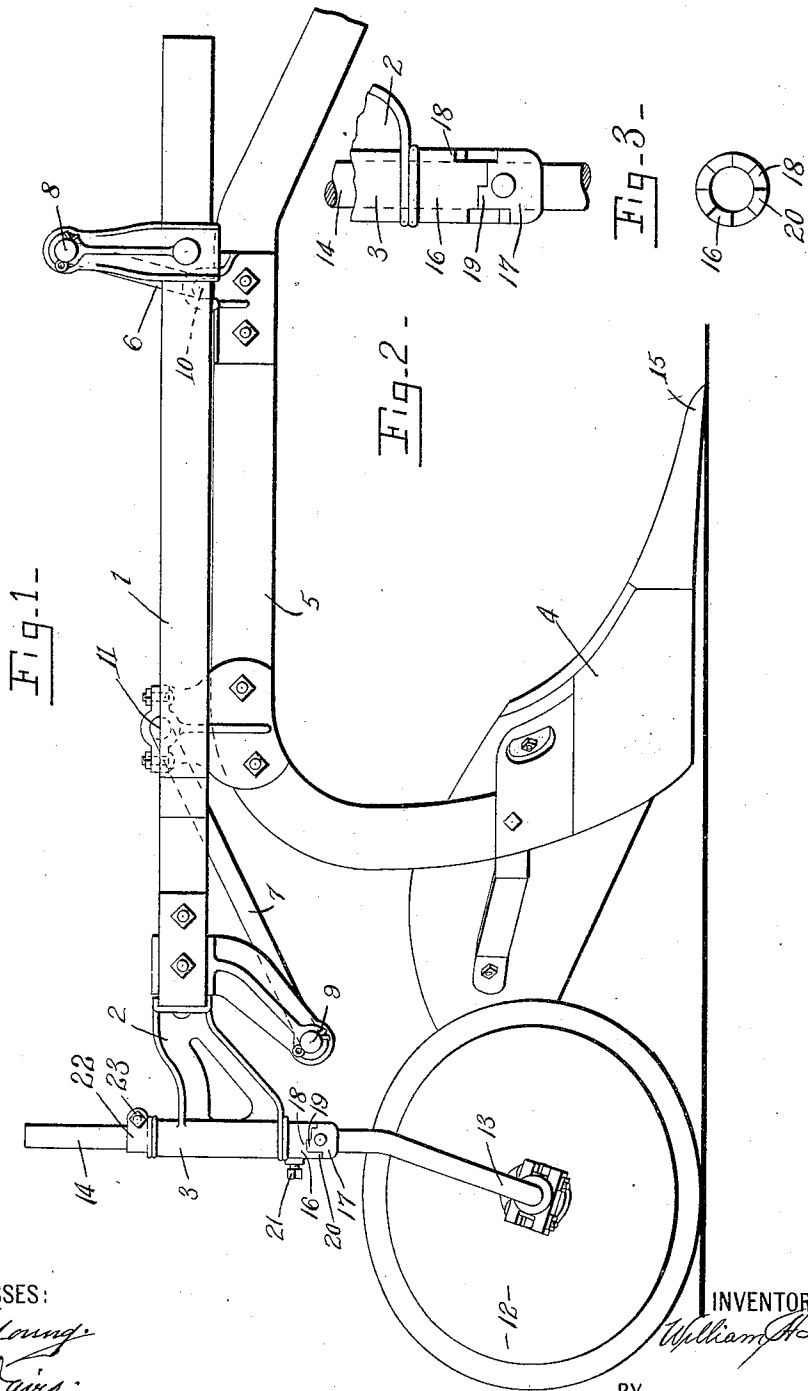

WITNESSES:

*Chas. Young*  
*S. Davis*

INVENTOR

*William H. Lee*

BY

*Parsons Hall & Bodeell*

ATTORNEYS

# UNITED STATES PATENT OFFICE.

WILLIAM H. LEE, OF SYRACUSE, NEW YORK, ASSIGNOR TO SYRACUSE CHILLED PLOW COMPANY, OF SYRACUSE, NEW YORK, A CORPORATION OF NEW YORK.

MEANS FOR TILTING THE EARTH-TURNING ELEMENTS OF WHEELED PLOWS.

1,069,340.

Specification of Letters Patent.

Patented Aug. 5, 1913.

Application filed February 8, 1909. Serial No. 476,625.

*To all whom it may concern:*

Be it known that I, WILLIAM H. LEE, of Syracuse, in the county of Onondaga and State of New York, have invented a certain new and useful Means for Tilting the Earth-Turning Elements of Wheeled Plows, of which the following is a specification.

My invention relates to wheeled plows, and has for its object the production of a particularly simple and efficient means for tilting the earth-turning element or plow proper in order to adjust the angle of the point of the earth-turning element; and it consists in the combinations and constructions hereinafter set forth and claimed.

In describing this invention reference is had to the accompanying drawing in which like characters designate corresponding parts in all the views.

Figure 1 is an elevation of a plow embodying my invention, parts being omitted. Fig. 2 is a detail view of parts seen in Fig. 1. Fig. 3 is an edge view of one of the cams.

1 is the frame of the plow, which frame may be of any desirable form, size and construction, it being here shown as formed with a rearwardly-extending bracket 2 which is provided with an upright bearing 3.

4 is an earth-turning element or plow proper, carried by the usual beam 5. The earth-turning element may be supported from the frame by any suitable means, here shown as front and rear bails or crank members 6 and 7 movable by any desirable operating means, and pivotally connected, respectively, at 8 and 9 to the frame, and at 10 and 11 to the beam 5 of the earth-turning element. The crank members 6 and 7 and the means for operating them, form no part of this invention.

12 is the rear furrow wheel carried by a suitable support 13 comprising an upwardly-extending spindle 14 journaled in the bearing 3.

The earth-turning element may be tilted to adjust the angle of the point 15, and, as here shown, said element is tilted by raising or lowering the rear end of the frame 1, relatively to the rear furrow wheel 12. The raising and lowering of the rear end of the frame is effected by means comprising upper and lower members or cams 16 and 17 preferably mounted on the spindle 14, these cams being sleeves, and the upper sleeve 16

shouldering against the lower edge of the bearing 3 and being movable about the spindle; and the lower sleeve 17 being fixed to and rigid with the spindle 3. The lower face of the upper cam is stepped, as seen in Fig. 2, and the upper face of the lower cam is stepped complementary to the lower stepped face of the upper cam 16, the engaging surfaces of the steps of the cams 16 and 17 being flat faces and thus facilitating the adjustment of the upper cam relatively to the lower cam.

By turning the upper sleeve 16 on the spindle 14, so that predetermined steps of the cams are in engagement with each other, the bearing 3 is moved lengthwise of the spindle 14, thereby raising or lowering the rear end of the frame 1 of the plow. When the lowest point or step 18 of the upper cam is in engagement with the highest point or step 19 of the lower cam, the frame 1 is in its lowest position, Fig. 1, and when the upper cam or sleeve 16 is turned so that a higher point or step as 20 of said sleeve 16 is engaged with the highest step of the lower cam, the frame 1 will be elevated above its lowest position. In whatever relative position, the cams are placed, save that in which the high steps of both cams are engaged, more than one of the shoulders or steps of said cams will be engaged, so that a large bearing surface is provided for the rear end of the frame. The movable or upper sleeve 16 is held in its adjusted position by a set screw 21 engaging the spindle 14, and the bearing 3 is held from upward movement on the spindle by an adjustable split sleeve 22 clamped on the spindle 14 by a screw 23 and movable into position to engage the upper end of the bearing 3.

What I claim is:—

1. In a wheeled plow, a frame, an earth-turning element supported by the frame, a support for the frame, means for raising and lowering the frame relatively to its support to change the position of the earth-turning element, said means comprising a pair of coacting members normally fixed to the support, one of the members being adjustable with the frame up and down relatively to the other, and said members being formed with stepped engaging faces and one of said members being adjustable relatively to the other and to the support bringing different steps of said members into engagement with each

other to effect the raising or lowering of the frame, and means for normally holding said members from movement relatively to the support, substantially as and for the purpose specified.

2. In a wheeled plow, a frame having an upwardly extended bearing, an earth-turning element supported by the frame, a wheel, a support for the wheel comprising a spindle journaled in the bearing, means for raising and lowering the frame relatively to the wheel, said means comprising two cams carried by and rotatable with the spindle and arranged one above the other, and having opposing faces engaging each other, one of the cams shouldering against the bearing and one of said cams being movable relatively to the other to effect the raising or lowering of the frame relatively to the wheel, and means for holding the movable cam in its adjusted position, said means being independent of the cam opposed to the movable cam, substantially as and for the purpose set forth.

3. In a wheeled plow, a frame having an upwardly extending bearing, an earth-turning element supported by the frame, a wheel, a support for the wheel comprising a spindle journaled in the bearing, a cam arranged on and rotatable with the spindle and shouldering against the lower end of the bearing, the cam having its lower face stepped, a cam arranged on the spindle below the first-mentioned cam and having its upper face stepped complementary to the stepped face of the first-mentioned cam, the engaging surfaces of the steps of said cams being flat faces, the lower cam being fixed from endwise movement on the spindle, and one of the cams being movable about the spindle for bringing predetermined steps of the cams in engagement and thereby effecting the raising or lowering of the frame relatively to the wheel, and means for holding the movable cam in its adjusted position, substantially as and for the purpose described.

4. In a wheeled plow, a frame having an upwardly extending bearing, an earth-turning element supported by the frame, a wheel,

a support for the wheel comprising a spindle journaled in the bearing, means for raising and lowering the frame relatively to the wheel, comprising two cams arranged one above the other on the spindle and normally movable with the spindle in its movement in the bearing, the lower cam being fixed to the spindle and the upper cam shouldering against the lower end of the bearing and being adjustable about the spindle to effect the raising or lowering of the frame relatively to the wheel, and means for normally holding the upper cam in its adjusted position, said means being independent of the lower cam, substantially as and for the purpose specified.

5. In a wheeled plow, a frame having an upwardly extending bearing at its rear end, an earth-turning element supported by the frame, a wheel, a support for the wheel comprising a spindle journaled in the bearing, a sleeve mounted on the spindle below the bearing and engaging the lower end of said bearing, the sleeve having its lower end face stepped and a cam fixed on the spindle below the sleeve and having its upper face stepped complementary to the stepped face of the sleeve, said sleeve being movable about the spindle for bringing predetermined steps of the sleeve and the cam into engagement with each other, to effect the raising and lowering of the frame relatively to the wheel, a plurality of the steps of the sleeve and the cam being engaged with each other save when the high steps of the sleeve and the cam are engaged, and means for normally holding the sleeve from movement about its axis, substantially as and for the purpose set forth.

In testimony whereof, I have hereunto signed my name in the presence of two attesting witnesses, at Syracuse, in the county of Onondaga, in the State of New York, this 5th day of January, 1909.

WILLIAM H. LEE.

Witnesses:

I. MANNING,  
C. R. DAVIS.