



US008726703B1

(12) **United States Patent**
Derman

(10) **Patent No.:** **US 8,726,703 B1**
(45) **Date of Patent:** **May 20, 2014**

(54) **LOW PROFILE LOCK INTERFACE SYSTEM AND METHOD**

(71) Applicant: **Jay S Derman**, Temecula, CA (US)

(72) Inventor: **Jay S Derman**, Temecula, CA (US)

(*) Notice: Subject to any disclaimer, the term of this patent is extended or adjusted under 35 U.S.C. 154(b) by 0 days.

(21) Appl. No.: **14/171,695**

(22) Filed: **Feb. 3, 2014**

Related U.S. Application Data

(63) Continuation-in-part of application No. 13/355,328, filed on Jan. 20, 2012, now Pat. No. 8,640,511.

(51) **Int. Cl.**
E05B 69/00 (2006.01)
E05B 73/00 (2006.01)

(52) **U.S. Cl.**
USPC **70/58; 70/33; 70/232; 70/386**

(58) **Field of Classification Search**
USPC 70/14, 18, 30-34, 49, 54-58, 232, 386, 70/DIG. 57; 248/551-553; 285/276-277
See application file for complete search history.

(56) **References Cited**

U.S. PATENT DOCUMENTS

4,751,831	A *	6/1988	Morris et al.	70/159
5,066,049	A *	11/1991	Staples	285/80
5,992,187	A *	11/1999	Derman	70/58
6,081,974	A *	7/2000	McDaid	24/265 CD
6,317,936	B1 *	11/2001	McDaid et al.	24/265 CD
6,360,405	B1 *	3/2002	McDaid et al.	24/265 R
6,672,115	B2 *	1/2004	Wyers	70/14

6,793,081	B1 *	9/2004	Derman	215/201
7,165,426	B2 *	1/2007	Wyers	70/14
7,225,649	B2 *	6/2007	Wyers	70/34
7,997,106	B2 *	8/2011	Mahaffey et al.	70/58
8,001,812	B2 *	8/2011	Mahaffey et al.	70/58
D646,951	S *	10/2011	Tsai	D8/330
8,074,478	B1 *	12/2011	Shu	70/58
8,107,236	B2 *	1/2012	Lin	361/679.57
8,151,604	B2 *	4/2012	Thomas et al.	70/14
8,640,511	B1 *	2/2014	Derman	70/58
2003/0196462	A1 *	10/2003	Chen	70/49
2006/0086160	A1 *	4/2006	Marszalek et al.	70/58
2007/0157680	A1 *	7/2007	DeMartinis et al.	70/57
2010/0170304	A1 *	7/2010	Anderson	70/21
2011/0005281	A1 *	1/2011	Lin	70/58
2011/0061427	A1 *	3/2011	Mahaffey et al.	70/58
2011/0089794	A1 *	4/2011	Mahaffey et al.	312/237
2012/0017656	A1 *	1/2012	Senatori	70/58

* cited by examiner

Primary Examiner — Lloyd Gall

Assistant Examiner — Richard G Davis

(74) *Attorney, Agent, or Firm* — Aaron P. McGushion

(57) **ABSTRACT**

A system for securing an item to an anchor is disclosed. The system may include a first extension extending from an item, an interface mechanism connected to the first extension, and a lock. The interface mechanism may include a cylindrical base, a sleeve, and a second extension. The cylindrical base may comprise an extension aperture receiving the first extension therewithin. The slide may surround at least a portion of the cylindrical base and occupy a blocking position locking the first extension within the extension aperture. The second extension may extend from the slide and comprise a traveler occupying a locking position locking the slide in the blocking position. The lock may engage the second extension and lock the traveler in the locking position.

15 Claims, 9 Drawing Sheets

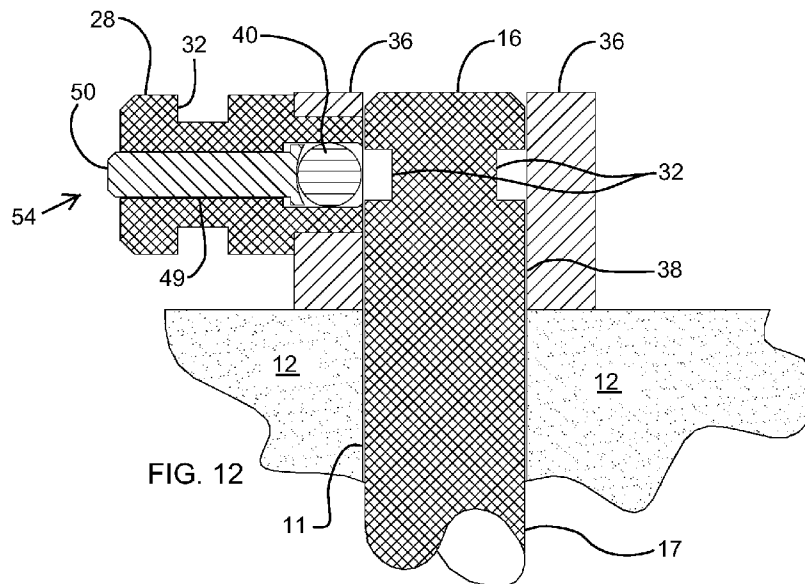
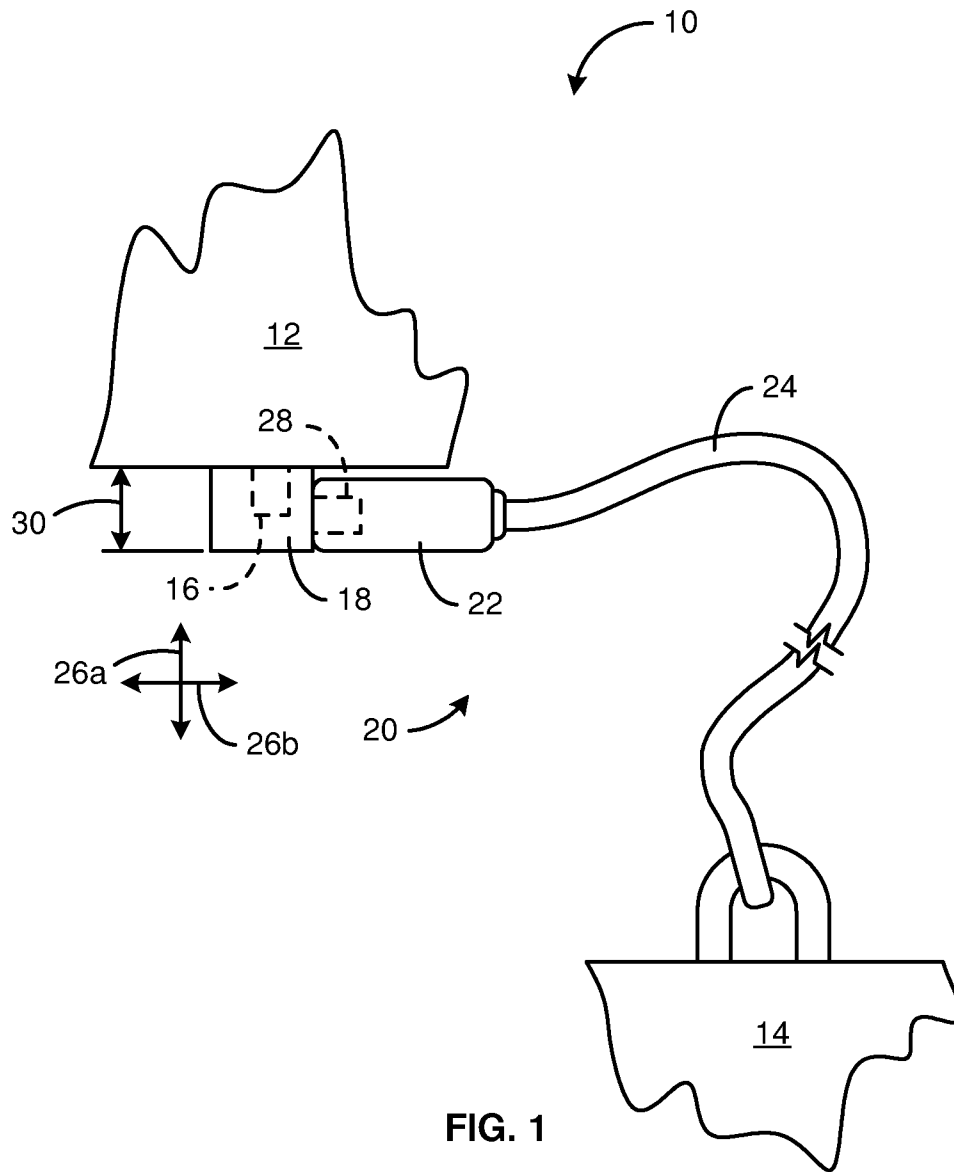

FIG. 12



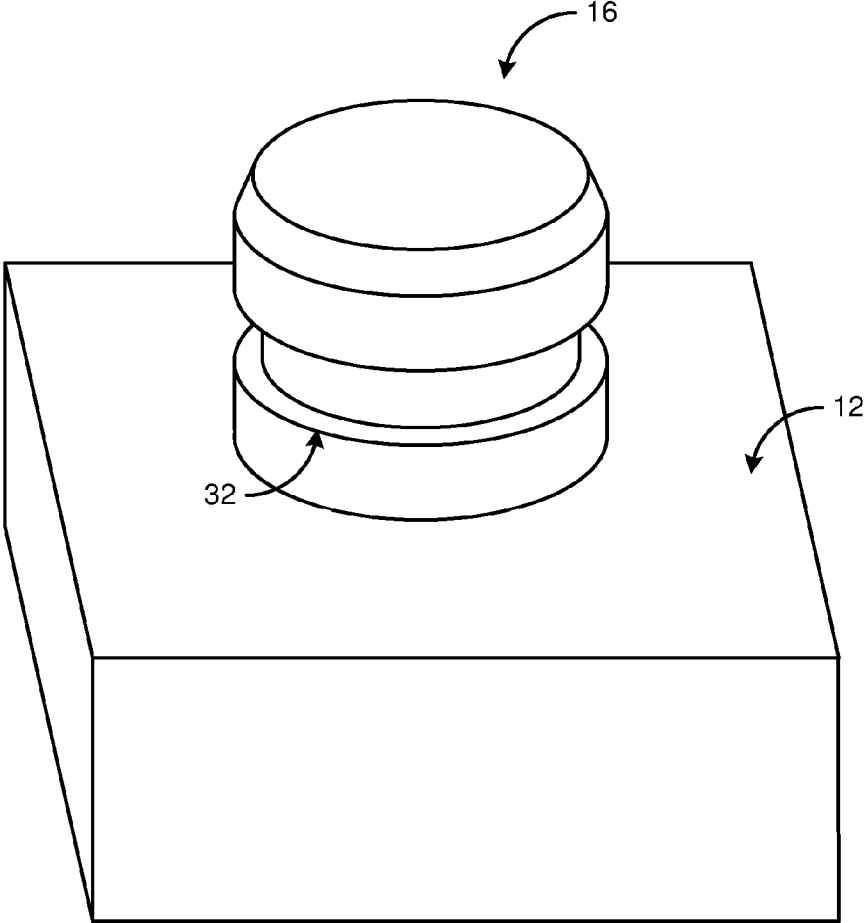

FIG. 2

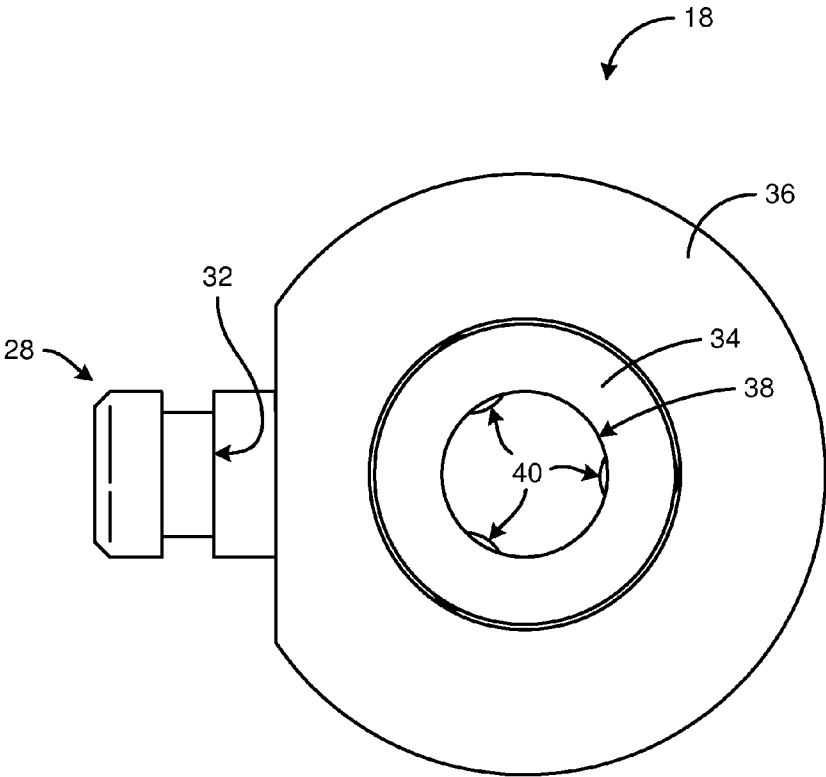
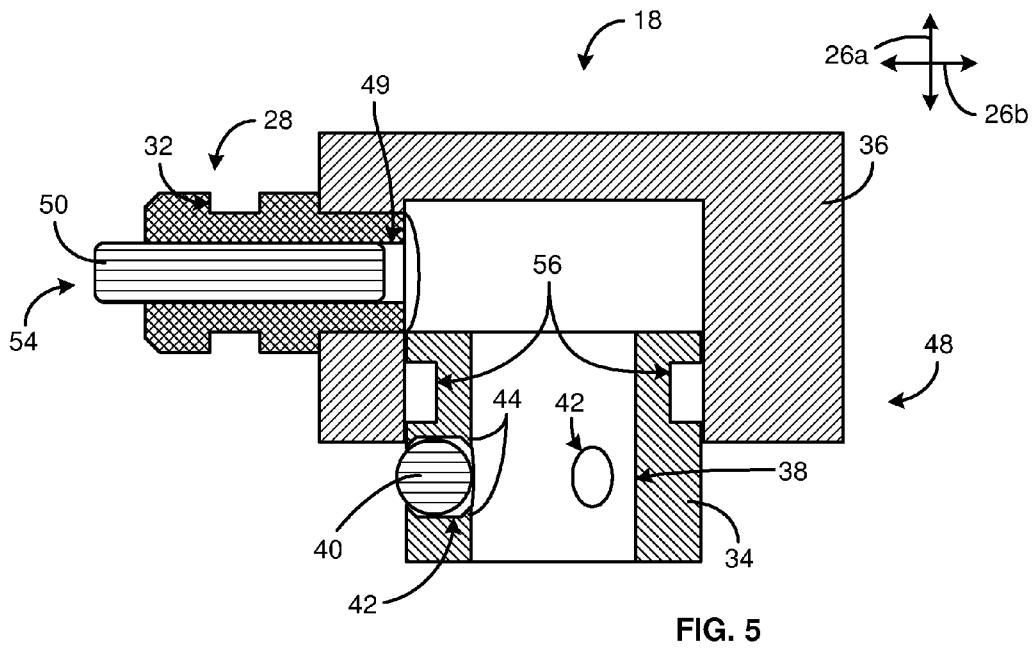
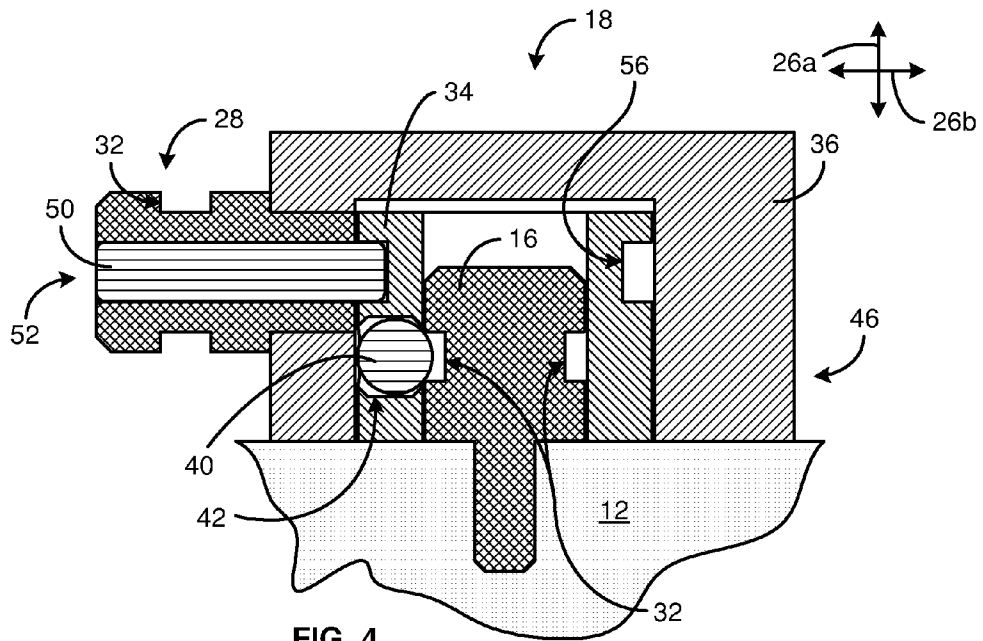
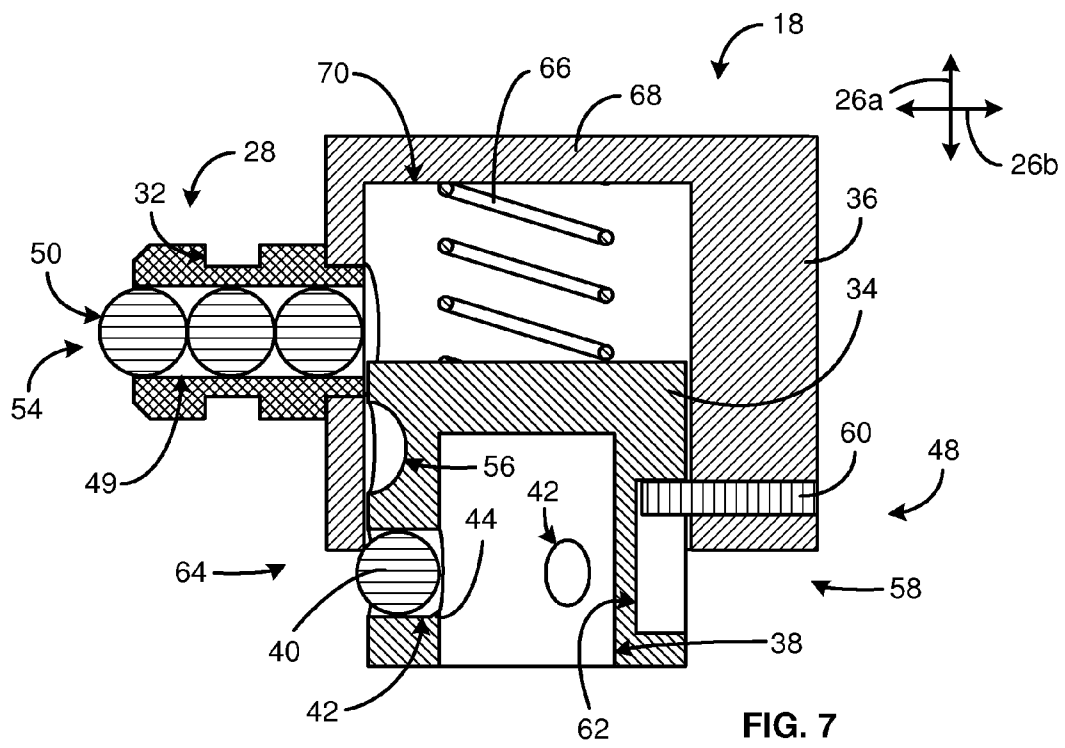
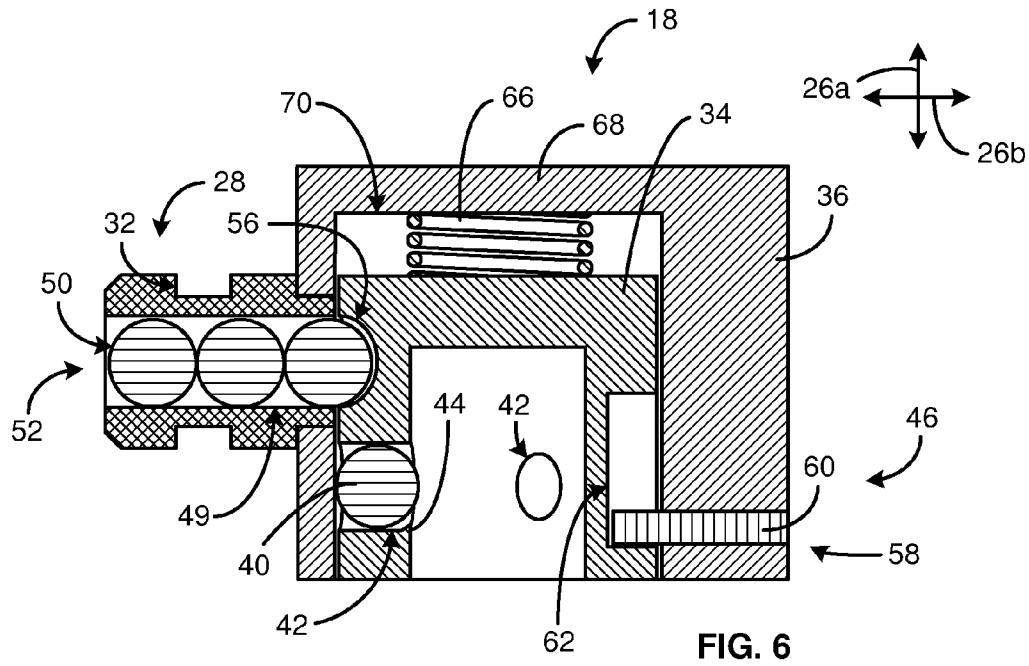
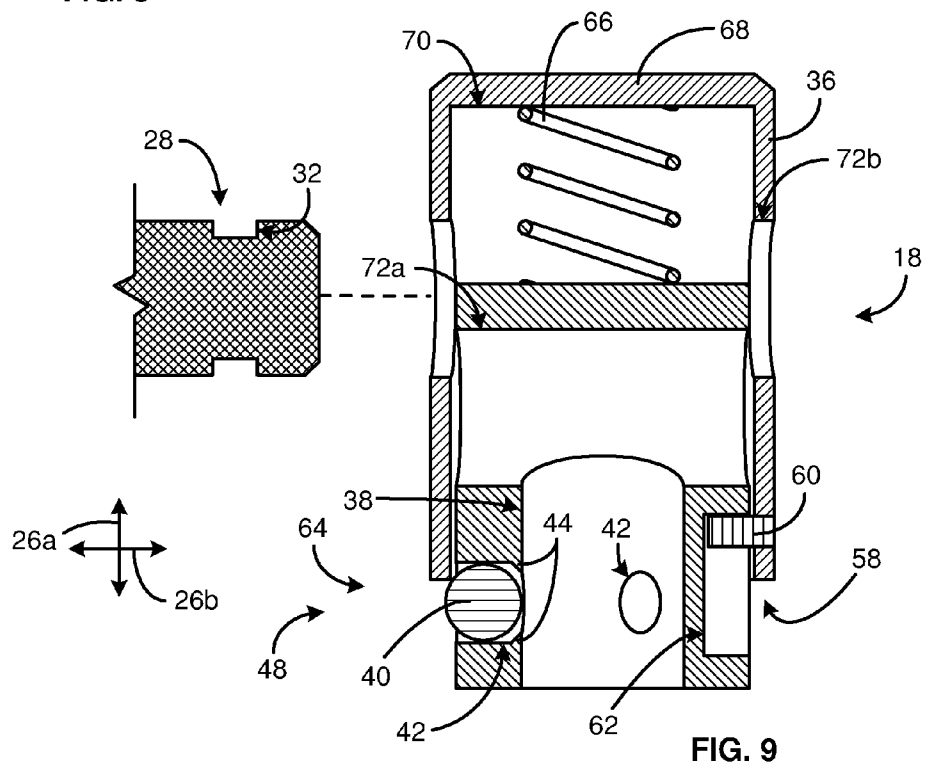
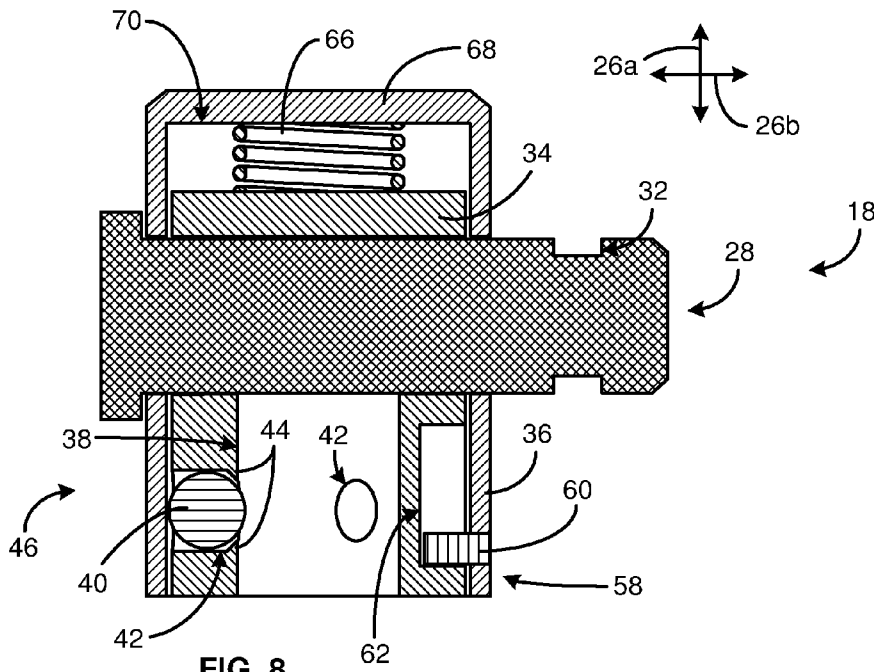
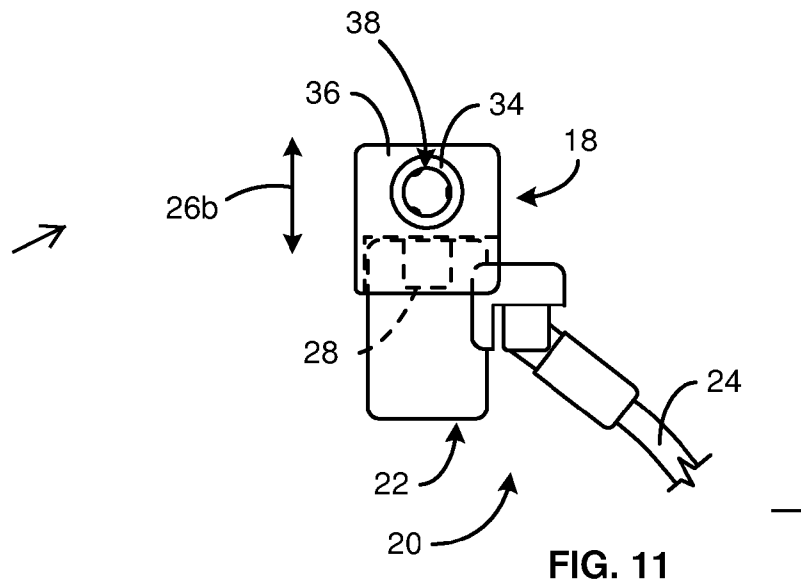
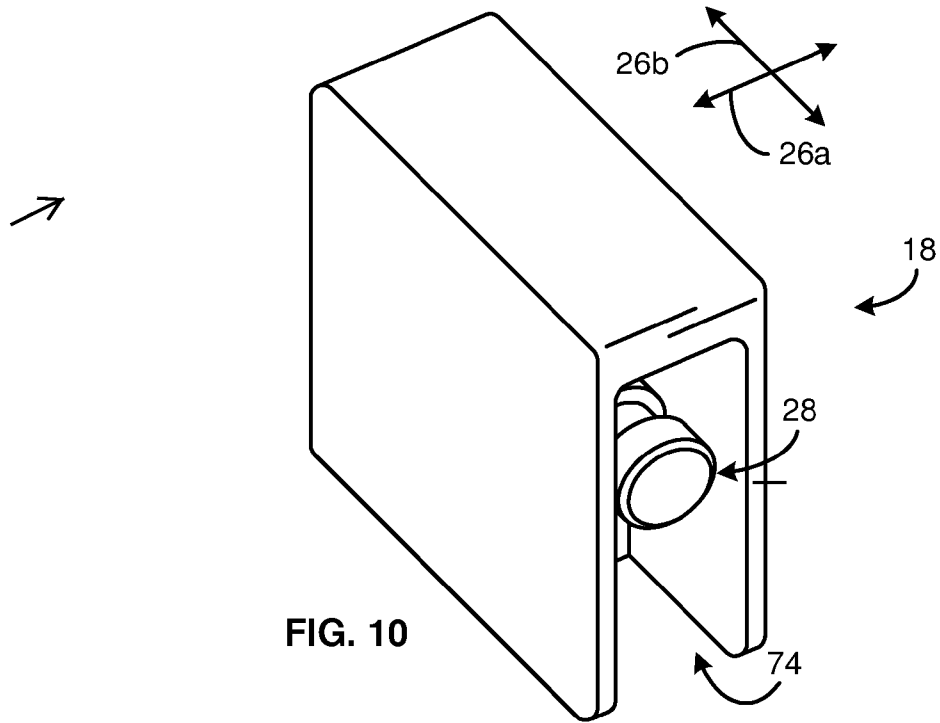

FIG. 3









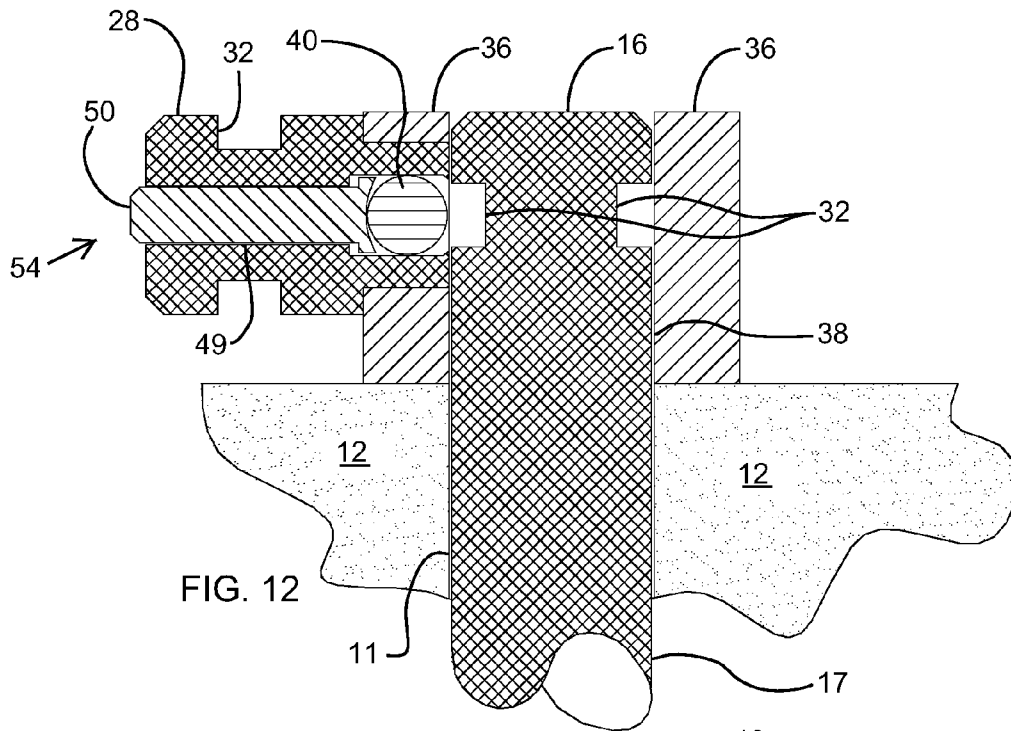

FIG. 12

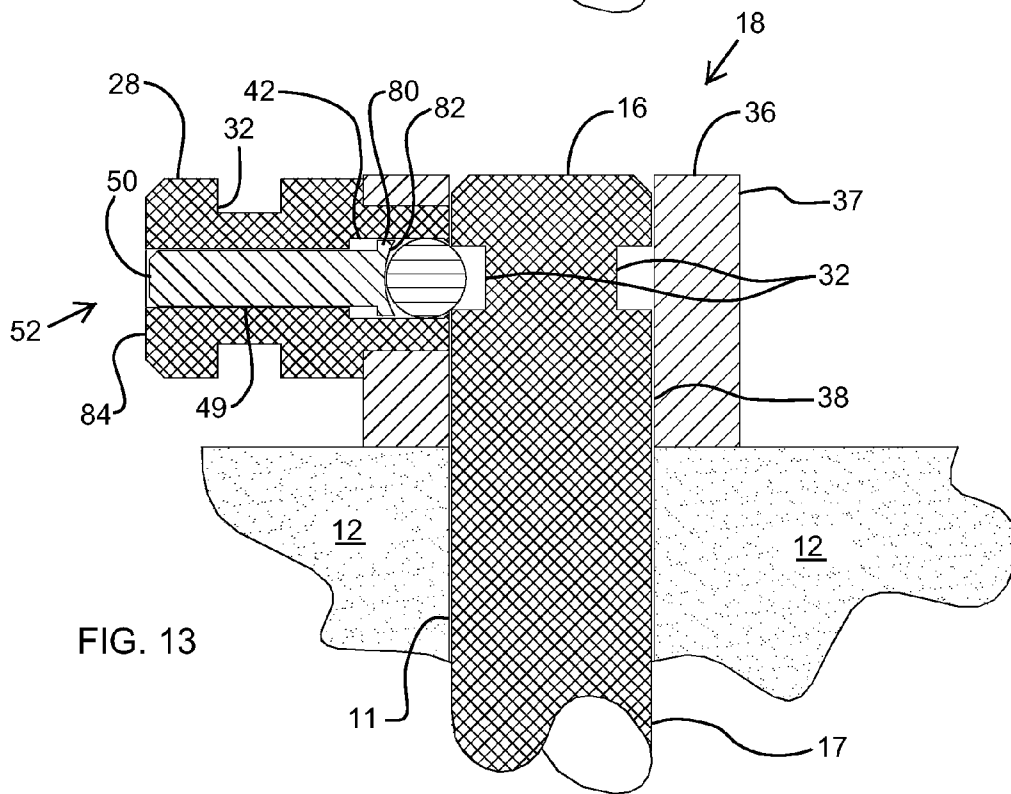

FIG. 13

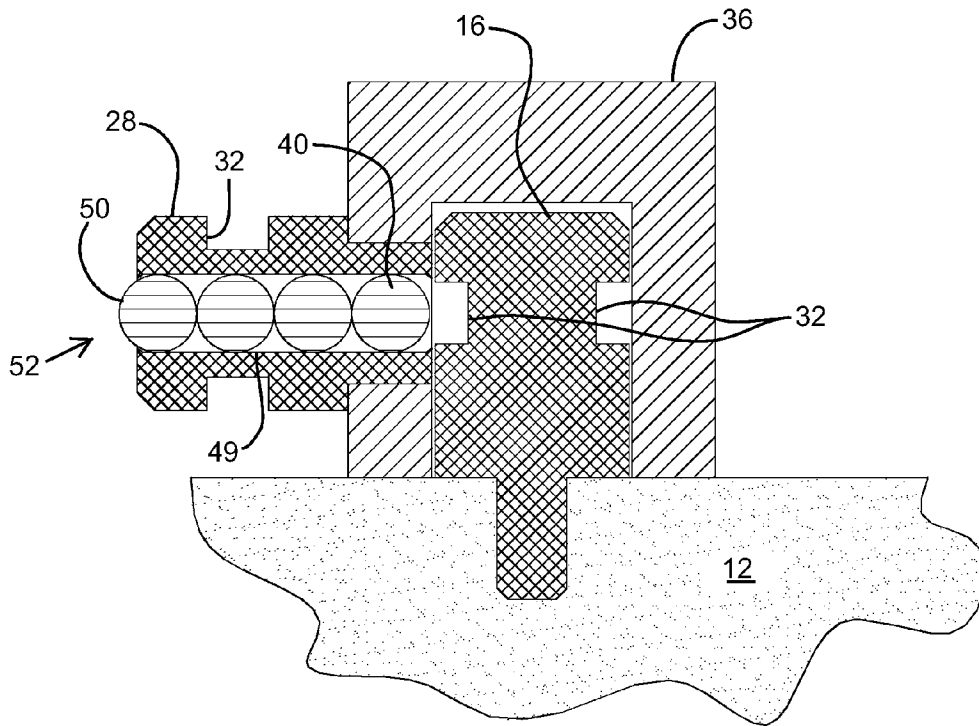

FIG. 14

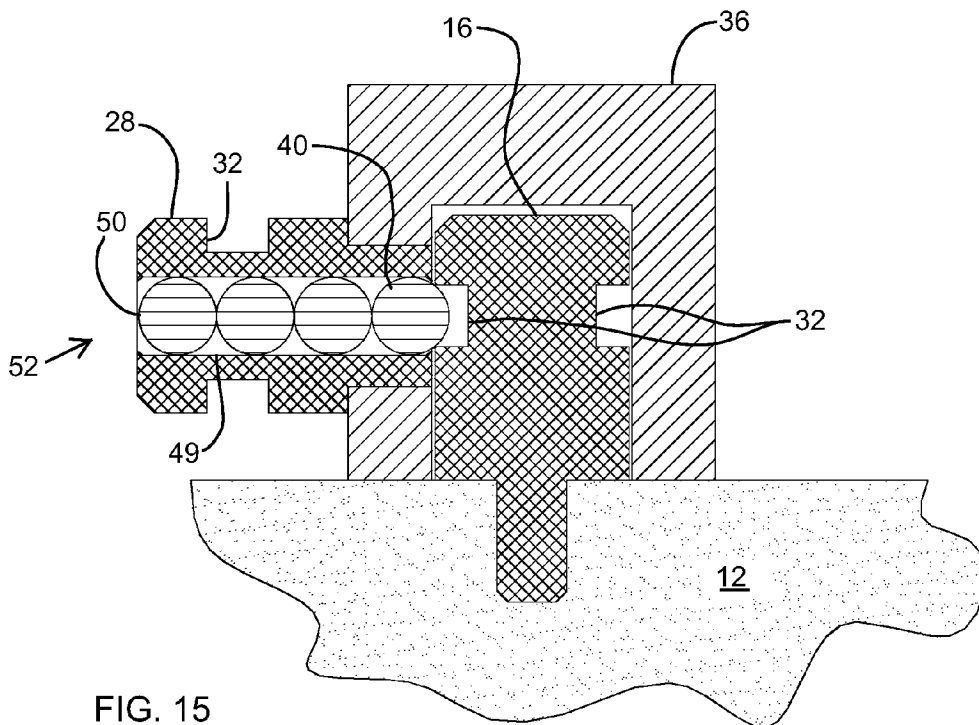

FIG. 15

LOW PROFILE LOCK INTERFACE SYSTEM AND METHOD

RELATED APPLICATION DATA

This application is a continuation-in-part of U.S. patent application Ser. No. 13/355,328, filed on Jan. 20, 2012, which will issue as U.S. Pat. No. 8,640,511 on Feb. 4, 2014, which is a continuation-in-part of U.S. patent application Ser. No. 13/270,439 filed Oct. 11, 5, 2011, which claims benefit from U.S. Provisional Application for Patent Application No. 61/533,898 filed Sep. 13, 2011. U.S. Provisional Patent Application Ser. No. 61/533,898, U.S. patent application Ser. No. 13/270,439, and U.S. patent application Ser. No. 13/355, 328 are hereby incorporated by reference.

BACKGROUND

This invention relates to security systems and, more particularly, to novel systems and methods for tethering personal property to an anchor.

As computers, expensive electronic equipment, and other valuable portable articles have become more common, theft of such articles has increased. There are a number of different devices on the market to deter such theft. However, most of these devices are either bulky, so that they are not particularly portable, or they rely on certain clearances. Accordingly, what is needed is an improved, low profile system and method for securing valuable portable articles.

SUMMARY

In view of the foregoing, in accordance with the invention as embodied and broadly described herein, a method and apparatus are disclosed in one embodiment of the present invention as including a system protecting an item from theft or unwanted removal. In selected embodiments, a system may include a lock, an anchor, and an interface mechanism. An interface mechanism may be connected to an extension extending from an item (e.g., valuable portable article). A lock may selectively engage an interface mechanism and extend therefrom to engage an anchor, thereby forming a secure tie or link from the item to the anchor.

In selected embodiments, an interface mechanism may include a base and a slide. A base may include an extension aperture formed therein. An extension aperture may be sized and shaped to receive therewithin an extension (e.g., an anchor extending from the item to be secured). To selectively secure an extension within an extension aperture, an interface mechanism may include one or more interference members. An interference member may extend to engage an extension and, thereby, resist the removal of the extension from the interface mechanism.

In certain embodiments, a base may include one or more interference apertures. Each interference aperture may contain, or partially contain, a corresponding interference member. Each interference member may extend from a corresponding interference aperture to engage an extension.

A slide may be configured to travel with respect to a base. For example, a slide may be configured to translate in the axial direction with respect to a corresponding base. In selected embodiment, a slide may move between one or more blocking positions and one or more non-blocking positions. In a blocking position, a slide may block an interference member from moving out of engagement with an extension.

Accordingly, when a slide is in a blocking position, an interface mechanism may be secured to a corresponding extension.

In a non-blocking position, a slide may permit an interference member to move within the corresponding interference aperture. Accordingly, with a slide in a non-blocking position, an interference member may move out of engagement with an extension. Accordingly, when a slide is in a non-blocking position, an interface mechanism may be easily removed from a corresponding extension.

In selected embodiments, an interface mechanism may include a second extension. A second extension, slide, or both may include a traveler aperture formed therein. A traveler aperture may be sized and shaped to receive a traveler there-within. A traveler may selectively move between one or more locking positions and one or more non-locking positions.

In a locking position, a traveler may extend to engage a base. Accordingly, when a traveler is in a locking position, an interface mechanism may be secured to (e.g., locked into) a corresponding first extension. In a non-locking position, a traveler may enable a slide to move with respect to a corresponding base. Accordingly, with a traveler in a non-locking position, a slide may move with respect to a base until one or more interference members are able to move out of engagement with a first extension. Accordingly, when a traveler is in a non-locking position, an interface mechanism may be easily removed from a corresponding item.

A traveler and second extension may form, when the traveler occupies certain positions (e.g., a locking position), a composite configuration, profile, or shape that is compatible with a lock. Accordingly, in such embodiments, when a lock engages a second extension, the lock may contact a traveler and prevent it from moving away from a base. As a result, a lock may confine a traveler to one or more locking positions.

In another embodiment an interface mechanism forms a connection between a first extension and a lock, where the first extension having a circumferential locking groove. A slide has a first extension aperture sized to receive the first extension therein. The slide has an outer wall and an inner wall, with the inner wall defining the first extension aperture. A second extension extends from the outer wall of the slide with a traveler aperture formed there through. The second extension is configured to receive the lock in locking engagement. An interference aperture communicates between the traveler aperture and the first extension aperture. An interference member is positioned at least in part within the interference aperture, with the interference member being movable from an extended position to a retracted position. In the extended position the interference member is engaged within the circumferential locking groove; and in the retracted position the interference member is disengaged from the circumferential locking groove. A traveler is positioned at least in part within the traveler aperture and is movable between a locking position and a non-locking position. In the locking position the traveler is positioned to hold the interference member in engagement within the circumferential locking groove; and in the non-locking position the traveler is positioned to permit the interference member to disengage from the circumferential locking groove. The lock can be engaged to the second extension to block the traveler in the locking position.

Optionally, the traveler and the interference member may be spherical. The traveler may be comprised of a plurality of spherical members. Optionally, the traveler may be cylindrical with the interference member being spherical. The trav-

eler may have an expanded head with a concave contacting surface configured to contact the spherical interference member in the locking position.

BRIEF DESCRIPTION OF THE SEVERAL VIEWS OF THE DRAWINGS

The foregoing features of the present invention will become more fully apparent from the following description and appended claims, taken in conjunction with the accompanying drawings. Understanding that these drawings depict only typical embodiments of the invention and are, therefore, not to be considered limiting of its scope, the invention will be described with additional specificity and detail through use of the accompanying drawings in which:

FIG. 1 is a schematic diagram of one embodiment of a system for securing an item in accordance with the present invention;

FIG. 2 is a perspective view of one embodiment of an extension in accordance with the present invention;

FIG. 3 is a bottom view of one embodiment of an interface mechanism in accordance with the present invention;

FIG. 4 is a cross-sectional view of the interface mechanism of FIG. 3 engaging an extension in accordance with the present invention with the slide in a blocking position;

FIG. 5 is a cross-sectional view of the interface mechanism of FIG. 3 with the slide in a non-blocking position;

FIG. 6 is a cross-sectional view of an alternative embodiment of an interface mechanism in accordance with the present invention with the slide in a blocking position and the traveler in a locking position;

FIG. 7 is a cross-sectional view of the interface mechanism of FIG. 6 with the slide in a non-blocking position and the traveler in a non-locking position;

FIG. 8 is a cross-sectional view of another alternative embodiment of an interface mechanism in accordance with the present invention with the slide in a blocking position;

FIG. 9 is a cross-sectional view of the interface mechanism of FIG. 8 with the slide in a non-blocking position;

FIG. 10 is a perspective view of another alternative embodiment of an interface mechanism in accordance with the present invention;

FIG. 11 is a bottom view of the interface mechanism of FIG. 10 secured to a lock;

FIG. 12 is a cross-sectional view of an embodiment of an interface mechanism for securing an item in accordance with the present invention in a non-locking position;

FIG. 13 is a cross-sectional view of the embodiment of FIG. 12 in a locking position;

FIG. 14 is a cross-sectional view of an embodiment of an interface mechanism for securing an item in accordance with the present invention in a non-locking position; and

FIG. 15 is a cross-sectional view of the embodiment of FIG. 14 in a locking position.

DESCRIPTION OF THE PREFERRED EMBODIMENTS

It will be readily understood that the components of the present invention, as generally described and illustrated in the drawings herein, could be arranged and designed in a wide variety of different configurations. Thus, the following more detailed description of the embodiments of the system and method of the present invention, as represented in the drawings, is not intended to limit the scope of the invention, as claimed, but is merely representative of various embodiments of the invention. The illustrated embodiments of the invention

will be best understood by reference to the drawings, wherein like parts are designated by like numerals throughout.

Referring to FIG. 1, a system 10 in accordance with the present invention may protect an item 12 (e.g., valuable portable article, laptop computer, digital music player, camera, or the like) from theft, unwanted removal, unauthorized use, or the like. In selected embodiments, this may be done by tethering an item 12 to an anchor 14. An anchor 14 may be an object that is substantially fixed in place (e.g., an embedded post or the like). Alternatively an anchor 14 may be an object sufficiently heavy, bulky, or both to rendering moving the object unpractical or undesirable. For example, an anchor 14 may comprise a desk, table, or the like that may be moved or dismembered, but only with significant effort or with the generation of unwanted attention from surrounding individuals.

In selected embodiments, an item 12 may include a first extension 16 extending therefrom. In such embodiments, a system 10 may include an interface mechanism 18 configured to receive and retain a first extension 16. A lock 20 may selectively (e.g., releasably) engage an interface mechanism 18 and extend therefrom to engage an anchor 14. In certain embodiments, a lock 20 may include a locking mechanism 22 and a flexible tether 24.

A locking mechanism 22 may be configured to selectively engage an interface mechanism 18. A locking mechanism 22 may prevent an interface mechanism 18 from releasing a corresponding first extension 16. A flexible tether 24 may comprise chain, cable, or the like. In selected embodiments, a flexible tether 24 may secure to a locking mechanism 20 and extend therefrom to engage (e.g., loop through or around) an anchor 14.

In certain embodiments, a lock 20 may be configured as or comprise a device disclosed in U.S. Pat. No. 6,081,974 issued Jul. 4, 2000, U.S. Pat. No. 6,317,936 issued Nov. 20, 2001, U.S. Pat. No. 6,360,405 issued Mar. 26, 2002, U.S. Pat. No. 7,997,106 issued Aug. 16, 2011, or U.S. Pat. No. 8,001,812 issued Aug. 23, 2011, each of which is hereby incorporated by reference. For example, a lock 20 may be configured as or comprise a device currently being sold by Kensington Computer Products Group under the CLICKSAFE trademark.

In selected embodiments, an interface mechanism 18 may enable a lock 20 to connect a first extension 16 in a confined space. That is, in certain situations or applications, a lock 20 or locking mechanism 22 that directly engages a first extension 16 may extend away from an item 12 too far in a first direction 26a. Accordingly, in such situations or applications, an interface mechanism 18 may engage the first extension 16 and present a second extension 28. The second extension 28 may extend in a direction different than the first extension 16 (e.g., in a second direction 26b angled with respect to the first direction 26a, orthogonal to the first direction 26a, or the like). Accordingly, the space 30 consumed by an interface mechanism 18 and locking mechanism 22 may be controlled or minimized and a lock 20 may engage the second extension 28 without extending into restricted space.

The various components of a system 10 in accordance with the present invention may be formed of any suitable materials. Suitable materials may be selected to provide a desired durability, strength, rigidity, toughness, or the like. For example, in selected embodiments, one or more of the components of an interface mechanism 18 may be formed of a polymer material. However, in other embodiments where greater stresses are expected, such components may be formed of a metal or metal alloy.

Referring to FIG. 2, first and second extensions 16, 28 in accordance with the present invention may have any suitable configuration or combination of configurations.

For example, a first extension 16 may connect to, or extend from, an item 12 in any suitable manner. In certain embodiments, a first extension 16 and one or more portions of a second extension 28 may be configured as an anchor disclosed in U.S. Pat. No. 6,081,974, U.S. Pat. No. 6,317,936, or U.S. Pat. No. 6,360,405. Alternatively, a first extension 16 and one or more portions of a second extension 28 may be configured as an attachment device disclosed in U.S. Pat. No. 7,997,106 or U.S. Pat. No. 8,001,812. In still other embodiments, a first extension 16 may be configured as an interface mechanism disclosed in U.S. patent application Ser. No. 13/216,076 filed Aug. 23, 2011, which is hereby incorporated by reference. In selected embodiments, first and second extensions 16, 28 may each include one or more mechanisms enabling a corresponding structure to engage therewith. For example, a first extension 16 may include a locking groove 32 enabling an interface mechanism 18 to selectively grip the first extension 16. Similarly, a second extension 28 may include a locking groove 32 enabling a locking mechanism 22 to selectively grip the second extension 28. In certain embodiments, a locking groove 32 may extend circumferentially about an extension 16, 28. Such a locking groove 32 may enable a corresponding interface mechanism 18 or locking mechanism 22 to pivot about the extension 16, 28, while maintaining a secure engagement therewith. Referring to FIGS. 3-5, an interface mechanism 18 may include a base 34 and a slide 36. In selected embodiments, an interface mechanism 18 or portion thereof may have a cylindrical or semi-cylindrical shape and define axial, radial, and circumferential directions. For example, a base 34 or portion thereof may have cylindrical shape. Accordingly, a base 34 may be referred to as a cylindrical base. Similarly, a slide 36 or portion thereof may have cylindrical shape. Accordingly, a slide 36 may be referred to as a cylindrical slide.

In certain embodiments, a base 34 may include a first extension aperture 38 formed therein. Such an aperture 38 may be sized and shaped to receive a first extension 16 there-within. In selected embodiments, a first extension 16 may be inserted in the axial direction (e.g., the first direction 26a) within a base 34.

An interface mechanism 18 may selectively secure a first extension 16 therewithin. Such securement may be accomplished in any suitable manner. In selected embodiments, an interface mechanism 18 may include one or more interference members 40. An interference member 40 may extend to engage a first extension 16 and, thereby, resist the removal of the first extension 16 from the interface mechanism 18.

In certain embodiments, a base 34 may include one or more interference apertures 42. Each interference aperture 42 may contain, or partially contain, a corresponding interference member 40. Each interference member 40 may extend from a corresponding interference aperture 42 to engage a first extension 16. For example, each interference member 40 may extend from a corresponding interference aperture 42 into a locking groove 32 of a first extension 16.

An interference member 40 may be maintained within an interference aperture 42 in any suitable manner. In selected embodiments, one or more constrictions 44 may maintain an interference member 40 in place. One or more constrictions 44 may be formed in an initial machining process, casting process, molding process, or the like. Alternatively, or in addition thereto, one or more constrictions 44 may be formed or installed in an assembly process.

For example, in selected embodiments, after an interference member 40 has been placed within a corresponding interference aperture 42, a locking ring may be installed to form a constriction 44 preventing inadvertent removal of the interference member 40 from the interference aperture 42. Alternatively, after an interference member 40 has been placed within an interference aperture 42, a portion (e.g., an opening) of an interference aperture 42 may be swaged or otherwise deformed to form a constriction 44 preventing inadvertent removal of the interference member 40. An interface mechanism 18 may include a plurality of interference members 40 and corresponding interference apertures 42. In selected embodiments, the number of interface mechanisms 40 may be selected to distribute the loads applied thereby to a corresponding extension 16. Such distribution may lower the stress imposed on the extension 16, interference members 40, base 34, slide 36, and the like. It may also balance such loading. In selected embodiments, three interference members 40, each contained within a corresponding interference aperture 42, uniformly distributed in a circumferential direction about an extension aperture 38 may be sufficient. An interference member 40 in accordance with the present invention may be biased toward a particular position or configuration. For example, an interference member 40 may be biased (e.g., by a spring or the like) radially inward within a corresponding interference aperture 42. Alternatively, an interference member 40 may be biased radially outward within a corresponding interference aperture 42. In still other embodiments, an interference member 40 may be unbiased and, when not confined by a slide 36, travel relatively freely within a corresponding interference aperture 42. An interference member 40 in accordance with the present invention may have any suitable shape. For example, an interference member 40 may be spherical. Accordingly, in selected embodiments, one or more interference members 40 may comprise metal balls such as those for ball bearings.

A slide 36 may be configured to travel with respect to a base 34. For example, a slide 36 may be configured to translate in the axial direction with respect to a corresponding base 34. In selected embodiment, a slide 36 may move between one or more blocking positions 46 and one or more non-blocking positions 48. In a blocking position 46, a slide 36 may block an interference member 40 from moving out of engagement with an extension 16 (e.g., out of engagement with a locking groove 32 of a first extension 16). Accordingly, when a slide 36 is in a blocking position 46, an interface mechanism 18 may be secured to (e.g., lock onto) a corresponding first extension 16.

In a non-blocking position 48, a slide 36 may permit an interference member 40 to move within the corresponding interference aperture 42. Accordingly, with a slide 36 in a non-blocking position 48, an interference member 40 may move out of engagement with an extension 16 (e.g., out of engagement with a locking groove 32 of a first extension 16). Accordingly, when a slide 36 is in a non-blocking position 48, an interface mechanism 18 may be easily removed from a corresponding first extension 16.

A slide 36 may provide a framework for supporting one or more other components of an interface mechanism 18. For example, in selected embodiments, a second extension 28 may extend from a slide 36. A second extension 28 may connect to, or extend from, a slide 36 in any suitable manner. For example, in certain embodiments, a second extension 28 may monolithically extend from a slide 36. Alternatively, a second extension 28 may be secured (e.g., bonded, welded, bolted, threaded, or the like) to a slide 36 in an assembly process.

In selected embodiments, a second extension **28**, slide **36**, or both may include a traveler aperture **49** formed therein. A traveler aperture **49** may be sized and shaped to receive a traveler **50** therewithin. A traveler **50** may selectively move through a range of motion within a traveler aperture **49**. In selected embodiments, a range of motion of a traveler **50** may include a locking portion and a non-locking portion. A locking portion may include one or more locking positions **52** of a traveler **50**. A non-locking portion may include one or more non-locking positions **54** of a traveler **50**.

A traveler **50** may be configured to translate within a corresponding traveler aperture **49**. For example, a traveler **50** may translate in the second direction **26b** between one or more locking positions **52** and one or more non-locking positions **54**. In a locking position **52**, a traveler **50** may extend to engage a base **34** (e.g., engage an locking aperture **56** or locking groove **56** formed within a base **34**). Accordingly, when a traveler **50** is in a locking position **52**, an interface mechanism **18** may be secured to (e.g., locked into) a corresponding first extension **16**.

In a non-locking position **54**, a traveler **50** may permit a slide **36** to move with respect to a corresponding base **34**. Accordingly, with a traveler **50** in a non-locking position **54**, a slide **36** may move with respect to a base **34** until one or more interference members **40** are able to move out of engagement with a first extension **16** (e.g., out of engagement with a circumferential groove **32** of a first extension **16**). Accordingly, when a traveler **50** is in a non-locking position **54**, an interface mechanism **18** may be easily removed from a corresponding item **12**.

A traveler **50** in accordance with the present invention may have any suitable configuration or shape. In selected embodiments, a traveler **50** may comprise one or more elements or components. For example, a traveler **50** may comprise a plurality of spherical balls. Alternatively, a traveler **50** may comprise a shaft or pin. A traveler **50** may communicate motion from one end thereof to the other. For example, one end of a traveler **50** may be positioned proximate an end of a second extension **28**. An opposite end of the traveler **50** may be positioned proximate an interior of a slide **36**. Accordingly, a traveler **50** may communicate motion imposed thereon at the second extension **28** to the interior of a slide **36** or vice versa.

In selected embodiments, a traveler **50** or portion thereof may cooperate with a second extension **28** to form a composite configuration, profile, or shape adapted to, or compatible with, a locking mechanism **22**. Accordingly, a locking mechanism **22** may selectively engage a second extension **28**, traveler **50**, or both to confine, limit, or control the motion of the traveler **50**.

For example, a traveler **50** and second extension **28** may form, when the traveler **50** occupies certain positions (e.g., a locking position **52**), a composite configuration, profile, or shape that is compatible with a locking head described in U.S. Pat. No. 7,997,106. Accordingly, in such embodiments, when a locking mechanism **22** engages a locking groove **32** of a second extension **28**, the locking mechanism **22** may contact a traveler **50** and prevent it from moving away from a base **34** (e.g., out of engagement with a locking aperture **56**). As a result, a locking mechanism **22** may confine a traveler **50** to certain positions (e.g., one or more locking positions **52**).

A traveler **50** may be maintained within a traveler aperture **49** in any suitable manner. In selected embodiments, one or more constrictions may maintain a traveler **50** in place. One or more constrictions (e.g., shoulders or the like) may be formed in an initial machining process, casting process, molding process, or the like. Alternatively, or in addition thereto, one or more

constrictions (e.g., locking rings, deformations, or the like) may be formed or installed in an assembly process.

A traveler **50** may be biased toward certain positions within a corresponding range of motion. For example, a biasing mechanism (e.g., spring, arrangement of attracting magnets, arrangement of repelling magnets, or the like) may bias a traveler **50** toward or away from a locking position **52**.

Referring to FIGS. **6** and **7**, in certain embodiments, removal of a locking mechanism **22** from a second extension **28** may enable a slide **36** to be completely removed from a corresponding base **34**. In other embodiments, it may be desirable to maintain a connection between a slide **36** and base **34** even after a locking mechanism **22** has been removed. Accordingly, in selected embodiments, an interface mechanism **18** may include one or more limiters **58**.

A limiter **58** may set one or more limits on the relative motion between a slide **36** and corresponding base **34**. In selected embodiments, a limiter **58** may limit rotation of a slide **36** about a base **34**, translation of a slide **36** with respect to a base **34**, or some combination thereof.

In certain embodiments, a limiter **58** may comprise a rider **60** and a corresponding slot **62**. Relative motion between a slide **36** and base **34** may provide relative motion of the rider **60** within the slot **62**. Accordingly, the shapes and sizes of the rider **60** and slot **62** may provide limits to the relative motion between the corresponding slide **36** and base **34**.

For example, a rider **60** may extend from one of a slide **36** and a base **34**. A slot **62** may be formed in the other of the slide **36** and base **34**. The slot **62** may have a width and depth enabling the rider **60** to travel therewithin. The slot **62** may have a first end spaced in the axial direction from a second end (e.g., the length of the slot **62** may be aligned with the axial direction). Relative motion of the slide **36** with respect to the base **34** may cause the rider **60** to travel within the slot **62**. Contact between a rider **60** and a first end of the slot **62** may define one limit to the axial travel of the slide **36** with respect to the base **34**. Alternatively, or in addition thereto, contact between a rider **60** and a second end of the slot **62** may define another limit to the axial travel of the slide **36** with respect to the base **34**. Meanwhile, contact between the rider **60** and one or more sides of the slot **62** may limit rotation of a slide **36** about a base **34**.

A rider **60** may extend from a base **34** or slide **36** in any suitable manner. For example, a rider **60** may be monolithically formed as part of a base **34** or slide **36**. This may be done in an initial machining process, casting process, molding process, or the like. Alternatively, a rider **60** may be formed or installed in an assembly process. For example, a rider **60** may be formed in an assembly process by inserting and securing a pin, bolt, screw, key, or the like into a slot **62**, by bending or swaging some material of a base **34** or slide **36** into a slot **62**, or the like.

A limiter **58** may prevent inadvertent disassembly an interface mechanism **18**. A limiter **58** may also enable a slide **36** to prevent inadvertent removal of one or more interference members **40**. For example, a limiter **58** may stop further motion of a slide **36** at a retaining position **64**. A retaining position **64** may be a non-blocking position **48** in that, in the retaining position **64**, one or more interference members **40** may be free to fully disengage a first extension **16**. However, a retaining position **64** may still enable a slide **36** to prevent the one or more interference members **40** from falling out of respective interference apertures **42**. Accordingly, in embodiments wherein a limiter **58** provides a retaining position **64**, certain constrictions **44** of one or more interference apertures **42** may be omitted.

In selected embodiments, an interface mechanism **18** may be biased. For example, an interface mechanism **18** may include one or more biasing members **66** (e.g., springs) biasing the interface mechanism **18** toward a blocking position **46**. Alternatively, one or more biasing member may bias an interface mechanism **18** toward a non-blocking position **48**.

A biasing member **66** may act on slide **36**, base **34**, or some combination thereof in any suitable manner. For example, in certain embodiments, a slide **36** may include an end cap **68**. An end cap **68** may define a cavity **70**. Such a cavity **70** may extend between the end cap **68** of a slide **36** and an adjacent end (e.g., axial end) of a base **34**. One or more biasing members **66** may be positioned within a cavity **70**. In selected embodiments, one or more biasing members **66** positioned within a cavity **70** may be pulled (e.g., stretched) as a slide **36** transitions from a blocking position **46** to a non-blocking position **48**. Accordingly, in such embodiments, a slide **36** may be biased toward a blocking position **46**. Alternatively, one or more biasing members **66** positioned within a cavity **70** may be compressed as a slide **36** transitions from a non-blocking position **48** to a blocking position **46**. Accordingly, in such embodiments, a slide **36** may be biased toward a non-blocking position **48**.

Referring to FIGS. **8** and **9**, in selected embodiments, an interface mechanism **18** may include a second extension aperture **72**. A second extension aperture **72** may extend through a base **34**, a slide **36**, or some combination thereof. In certain embodiments, a second extension aperture **72** may extend in a radial direction. For example, a second extension aperture **72** may extend diametrically through an interface mechanism **18**.

A second extension aperture **72** may also enable a second extension **28** to secure a slide **36** with respect to a base **34**. For example, a second extension aperture **72** may enable a second extension **28** to lock a slide **34** in a blocking position **46**, thereby, enabling a secure connection from a first extension **16** to an interface mechanism **18** and from the interface mechanism **18** to a locking mechanism **22**.

In certain embodiments, a second extension aperture **72** may comprise multiple portions **72a**, **72b**. A first portion **72a** may comprise a second extension aperture formed within or through a base **34**. A second portion **72b** may comprise a second extension aperture form within or through a slide **36**. When the first and second portions **72a**, **72b** align, a second extension **28** may be inserted therethrough and restrict relative motion between the base **34** and the slide **36**. The first and second portions **72a**, **72b** may be configured to align when the slide **36** is in a blocking position **46**. Accordingly, when inserted through the first and second portions **72a**, **72b**, a second extension **28** may secure a slide **36** in a blocking position **46**. A locking mechanism **22** engaging an end of the second extension **28** may secure the second extension **28** within the second extension aperture **72**.

Referring to FIGS. **10** and **11**, in selected embodiments, a slide **36** may have a non-cylindrical shape. For example, a slide **36** may have a somewhat rectangular shape. Alternatively, or in addition thereto, a slide **36** may include a pocket **74**, recess **74**, aperture **74**, or the like for receiving a lock **20** or portion thereof. For example, a slide **36** may include a pocket **76** with a second extension **28** positioned therewithin. Accordingly, a locking mechanism **22** may extend into the pocket **74** to engage the second extension **28**.

A pocket **74** may improve the security of the engagement between a locking mechanism **22** and a second extension **28**. A pocket **74** may also limit the motion of a locking mechanism **22** with respect to a corresponding interface mechanism **18** (e.g., resist pivoting of a locking mechanism **22** about a

second extension **28**). Alternatively, or in addition thereto, a pocket **74** may provide a more aesthetically pleasing interface between an interface mechanism **18** and a lock **20**.

Looking now at FIGS. **12-15**, alternate embodiments of the invention are shown with the base **34** eliminated. Thus, the interference member **40** is positioned within the interference aperture within the slide **36** or the second extension **28**; and the traveler **50** directly pushes the interference member **40** into the locking groove **32** of the first extension **16**. In particular, viewing FIGS. **12** and **13**, an interface mechanism **18** includes a slide **36** with a first extension aperture **38** formed as a blind hole or a through hole. The first extension aperture **38** is sized to receive the first extension **16**. The first extension **16** may be mounted or attached to an item **12** or may be formed at the end of an elongate shaft **17**. The elongate shaft **17** can be inserted through an item **12**, which may be a portion of a secured object (laptop, etc.) or a bracket device. The bracket device may be configured to engage the secured object when the lock is attached to the first extension **16**.

A second extension **28** is attached to the slide **36** by press fitting, threading, welding, or the like. Alternatively, the second extension **28** may be machined or molded unitarily with the slide **36**. The second extension **28** is usually cylindrical with a circumferential locking groove **32** formed near the terminus **84**. A cylindrical traveler aperture **49** is drilled through the cylindrical axis of the second extension **28**, from the terminus **84** to the first extension aperture **38** of the slide **36**. In this example embodiment, the traveler **50** is a cylindrical rod with an expand head **80** with a concave contacting surface **82**. The interference aperture **42** is aligned with the traveler aperture **49**, and is slightly larger in diameter than the traveler aperture **49**. The expanded head **80** is located within the interference aperture **42**, with the expanded head **80** preventing withdrawal of the traveler **50** due reduction in diameter between the interference aperture **42** and the traveler aperture **49**. The slide **36** is shown as a being cylindrical, with the first extension aperture **38** drilled completely through.

In the illustrated example, the traveler **50** is inserted from the interference aperture **42**, followed by the spherical interference member **40**. The open end of the interference aperture **42** is swaged to prevent withdrawal of the interference member **40** and traveler **50** from the interference aperture **42** side. Then, the second extension **28** is pressed into the slide **36**, such that the interference member **40** may extend into the first extension aperture **38** when the traveler **50** is pushed axially towards the interference member **40**. The contacting surface **82** of the expanded head **80** contacts the interference member **40**, although it is not required that they remain in constant contact.

FIG. **12** shows the interface mechanism **18** with the traveler in the non-locking position **54**. The traveler **50**, is free to axially move towards the terminus **84** of the second extension **28**, as there is no attached lock to prevent movement. The spherical interference member **40** is permitted to retract from engagement with the circumferential locking groove **32** of the first extension **16**. In this configuration, the slide **36** may be removed from the first extension **16**. Although the interference aperture **42** is shown aligned or concentric with the traveler aperture **49**, alignment is not required, since it is only necessary that the traveler **50** push upon the interference member **40**.

FIG. **13** shows the interface mechanism **18** with the traveler in the locking position **52**. The traveler **50** is pushed into the interference member **40**, causing it to become engaged with the circumferential locking groove **32** of the first extension **16**. A lock can be attached to the second extension **28** to block the traveler **50** from movement out of the traveler aperture **49**

11

on the terminus **84**. The spherical interference member **40** is held into the first extension aperture **38** and into the circumferential locking groove **32** to prevent the slide **36** from being removed from the first extension **16**. Once the lock has been removed from the second extension **28**, the slide **36** may be pulled away from the first extension **16**, with the pulling action causing the spherical interference member **40** to be pushed out of the circumferential locking groove **32**, the traveler **50** following the interference member **40** movement.

FIGS. **14-15** show yet another embodiment of the interface member **18**, which is similar in basic construction as the embodiment of FIGS. **12-13**, except the traveler **50** is a plurality of spherical balls. In this example, the traveler aperture **49** and the interference aperture **42** are formed as the same cylindrical bore. A plurality of spherical balls (ball bearings or the like) are placed in-line within the traveler aperture **49**, with the traveler aperture **49** swaged at both openings to confine the balls. The most inwardly positioned ball acts as the interference member **40**, where the several ball push upon the interference member to cause it to engage with the circumferential locking groove **32**. The ball that comprises the interference member **40** may be of a different diameter than the remaining balls.

The present invention may be embodied in other specific forms without departing from its spirit or essential characteristics. The described embodiments are to be considered in all respects only as illustrative, and not restrictive. The scope of the invention is, therefore, indicated by the appended claims, rather than by the foregoing description. All changes which come within the meaning and range of equivalency of the claims are to be embraced within their scope.

What is claimed is:

1. An interface mechanism for forming a connection between a first extension and a lock, the first extension having a circumferential locking groove, the interface mechanism comprising:

a slide with a first extension aperture sized to receive the first extension therein, the slide having an outer wall, the slide having an inner wall defining the first extension aperture;

a second extension extending from the outer wall of the slide, a traveler aperture formed through the second extension, the second extension configured to receive the lock in locking engagement;

an interference aperture communicating between the traveler aperture and the first extension aperture;

an interference member positioned at least in part within the interference aperture, the interference member being movable from an extended position to a retracted position, in the extended position the interference member is engaged within the circumferential locking groove, in the retracted position the interference member is disengaged from the circumferential locking groove; and

a traveler positioned at least in part within the traveler aperture and being movable between a locking position and a non-locking position, in the locking position the traveler being positioned to hold the interference member in engagement within the circumferential locking groove, in the non-locking position the traveler being

12

positioned to permit the interference member to disengage from the circumferential locking groove; wherein the lock engages the second extension and blocks the traveler in the locking position.

2. The interface mechanism of claim **1** wherein the second extension extends orthogonally to the first extension, the traveler aperture communicating between a terminus of the second extension and the inner wall.

3. The interface mechanism of claim **2** wherein the traveler is spherical and the interference member is spherical.

4. The interface mechanism of claim **3** wherein the traveler is configured to extend from the traveler aperture at the terminus when in the non-locking position, and the traveler is configured to be pushed further into the traveler aperture by contact with the lock attached to the second extension when in the locking position.

5. The interface mechanism of claim **2** wherein the traveler is cylindrical and the interference member is spherical.

6. The interface mechanism of claim **5** wherein the traveler extends through the traveler aperture and is configured to extend from the traveler aperture at the terminus when in the non-locking position, and the traveler is configured to be pushed further into the traveler aperture by contact with the lock attached to the second extension when in the locking position.

7. The interface mechanism of claim **6** wherein the interference aperture is larger in diameter than the traveler aperture, the traveler further comprising an expanded head, the expanded head being positioned within the interference aperture, the expanded head contacting the interference member in the locking position to hold the interference member in engagement within the circumferential locking groove of the first extension.

8. The interface mechanism of claim **7** wherein a contacting surface of the expanded head contacts the spherical member in the locking position, the contacting surface being concave.

9. The interface mechanism of claim **5** wherein a cylindrical axis of the traveler is aligned with a center of the interference member.

10. The interface mechanism of claim **1** wherein the first extension is an elongate shaft.

11. The interface mechanism of claim **10** wherein the elongate shaft is configured to be inserted through a hole in an item.

12. The interface mechanism of claim **11** wherein the item is a bracket configured for engaging a portion of a secured object.

13. The interface mechanism of claim **1**, further comprising an anchor and a flexible tether extending to tie the lock to the anchor.

14. The interface mechanism of claim **1**, wherein the traveler aperture is cylindrical and the traveler is cylindrical, the traveler configured to axially travel within the traveler aperture.

15. The interface mechanism of claim **1**, wherein a plurality of spherical travelers are positioned within the traveler aperture.

* * * * *