



- (51) International Patent Classification:
G03F 7/20 (2006.01) H01L 21/027 (2006.01)
G03F 7/00 (2006.01)
- (21) International Application Number:
PCT/US2017/047742
- (22) International Filing Date:
21 August 2017 (21.08.2017)
- (25) Filing Language: English
- (26) Publication Language: English
- (30) Priority Data:
62/421,932 14 November 2016 (14.11.2016) US
- (71) Applicant: KLA-TENCOR CORPORATION [US/US];
Legal Department, One Technology Drive, Milpitas, California 95035 (US).
- (72) Inventors: AMIT, Eran; Geva 3/6 Pardes Hanna-Karkur, 37061 Haifa (IL). VOLKOVICH, Roie; Shderot Alexander 10/10, 3824969 Hadera (IL). YERUSHALMI, Liran; 43 Inbar, 30900 Zicron Yaacob (IL).
- (74) Agent: MCANDREWS, Kevin et al.; KLA-Tencor Corporation, Legal Department, One Technology Drive, Milpitas, California 95035 (US).
- (81) Designated States (unless otherwise indicated, for every kind of national protection available): AE, AG, AL, AM, AO, AT, AU, AZ, BA, BB, BG, BH, BN, BR, BW, BY, BZ, CA, CH, CL, CN, CO, CR, CU, CZ, DE, DJ, DK, DM, DO, DZ, EC, EE, EG, ES, FI, GB, GD, GE, GH, GM, GT, HN, HR, HU, ID, IL, IN, IR, IS, JO, JP, KE, KG, KH, KN, KP, KR, KW, KZ, LA, LC, LK, LR, LS, LU, LY, MA, MD, ME, MG, MK, MN, MW, MX, MY, MZ, NA, NG, NI, NO, NZ, OM, PA, PE, PG, PH, PL, PT, QA, RO, RS, RU, RW, SA, SC, SD, SE, SG, SK, SL, SM, ST, SV, SY, TH, TJ, TM, TN, TR, TT, TZ, UA, UG, US, UZ, VC, VN, ZA, ZM, ZW.
- (84) Designated States (unless otherwise indicated, for every kind of regional protection available): ARIPO (BW, GH, GM, KE, LR, LS, MW, MZ, NA, RW, SD, SL, ST, SZ, TZ, UG, ZM, ZW), Eurasian (AM, AZ, BY, KG, KZ, RU, TJ, TM), European (AL, AT, BE, BG, CH, CY, CZ, DE, DK, EE, ES, FI, FR, GB, GR, HR, HU, IE, IS, IT, LT, LU, LV, MC, MK, MT, NL, NO, PL, PT, RO, RS, SE, SI, SK, SM,

(54) Title: LITHOGRAPHY SYSTEMS WITH INTEGRATED METROLOGY TOOLS HAVING ENHANCED FUNCTIONALITIES

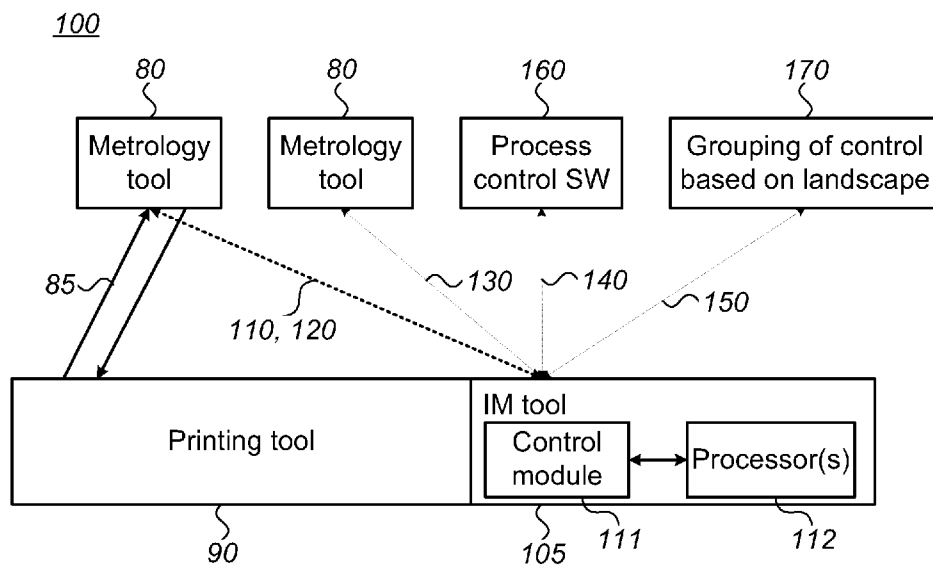

Figure 7

(57) Abstract: Lithography systems and methods are provided with enhanced performance based on broader utilization of the integrated metrology tool in the printing tool to handle the metrology measurements in the system in a more sophisticated and optimized way. Additional operation channels are disclosed, enabling the integrated metrology tool to monitor and/or allocate metrology measurements thereby and by a standalone metrology tool with respect to specified temporal limitations of the printing tool; to adjust and optimize the metrology measurement recipes; to provide better process control to optimize process parameters of the printing tool; as well as to group process parameters of the printing tool according to a metrology measurements landscape.



TR), OAPI (BF, BJ, CF, CG, CI, CM, GA, GN, GQ, GW,
KM, ML, MR, NE, SN, TD, TG).

Published:

— *with international search report (Art. 21(3))*

LITHOGRAPHY SYSTEMS WITH INTEGRATED METROLOGY TOOLS HAVING ENHANCED FUNCTIONALITIES

CROSS REFERENCE TO RELATED APPLICATIONS

[0001] This application claims the benefit of U.S. Provisional Patent Application No. 62/421,932 filed on November 14, 2016, which is incorporated herein by reference in its entirety.

BACKGROUND OF THE INVENTION

1. TECHNICAL FIELD

[0002] The present invention relates to the field of metrology, and more particularly, to optimized lithography systems.

2. DISCUSSION OF RELATED ART

[0003] Lithography system have to handle continuously growing complexity, smaller printing nodes and increases in metrology input, within shrinking printing time requirements.

SUMMARY OF THE INVENTION

[0004] The following is a simplified summary providing an initial understanding of the invention. The summary does not necessarily identify key elements nor limits the scope of the invention, but merely serves as an introduction to the following description.

[0005] One aspect of the present invention provides a lithography system comprising: a printing tool with an integrated metrology tool, and a standalone metrology tool connected to the printing tool and configured to perform metrology measurements on wafers produced by the printing tool, wherein the lithography system further comprises a monitoring channel connecting the integrated metrology tool with the standalone metrology tool, and the integrated metrology tool is further configured to allocate metrology measurements between the integrated metrology tool and the standalone

metrology tool and monitor the allocation and the metrology measurement with respect to specified temporal limitations of the printing tool.

[0006] These, additional, and/or other aspects and/or advantages of the present invention are set forth in the detailed description which follows; possibly inferable from the detailed description; and/or learnable by practice of the present invention.

BRIEF DESCRIPTION OF THE DRAWINGS

[0007] For a better understanding of embodiments of the invention and to show how the same may be carried into effect, reference will now be made, purely by way of example, to the accompanying drawings in which like numerals designate corresponding elements or sections throughout.

[0008] In the accompanying drawings:

[0009] **Figure 1** is a high level schematic block diagram illustration of lithography systems according to the prior art.

[0010] **Figure 2** is a high level schematic block diagram illustrating lithography systems with improved process tracking and metrology measurement analysis, according to some embodiments of the invention.

[0011] **Figures 3 and 4** are high level schematic block diagrams illustrating lithography systems with recipe optimization at the level of the integrated metrology tool, according to some embodiments of the invention.

[0012] **Figure 5** is a high level schematic block diagram illustrating of lithography systems with improved process control, according to some embodiments of the invention.

[0013] **Figure 6** is a high level schematic block diagram illustrating of lithography systems with landscape-based grouping, according to some embodiments of the invention.

[0014] **Figure 7** is a high level schematic block diagram illustrating of lithography systems with various configurations of channels disclosed above, according to some embodiments of the invention.

[0015] **Figure 8** is a high level flowchart illustrating a method, according to some embodiments of the invention.

DETAILED DESCRIPTION OF THE INVENTION

[0016] In the following description, various aspects of the present invention are described. For purposes of explanation, specific configurations and details are set forth in order to provide a thorough understanding of the present invention. However, it will also be apparent to one skilled in the art that the present invention may be practiced without the specific details presented herein. Furthermore, well known features may have been omitted or simplified in order not to obscure the present invention. With specific reference to the drawings, it is stressed that the particulars shown are by way of example and for purposes of illustrative discussion of the present invention only, and are presented in the cause of providing what is believed to be the most useful and readily understood description of the principles and conceptual aspects of the invention. In this regard, no attempt is made to show structural details of the invention in more detail than is necessary for a fundamental understanding of the invention, the description taken with the drawings making apparent to those skilled in the art how the several forms of the invention may be embodied in practice.

[0017] Before at least one embodiment of the invention is explained in detail, it is to be understood that the invention is not limited in its application to the details of construction and the arrangement of the components set forth in the following description or illustrated in the drawings. The invention is applicable to other embodiments that may be practiced or carried out in various ways as well as to combinations of the disclosed embodiments. Also, it is to be understood that the phraseology and terminology employed herein are for the purpose of description and should not be regarded as limiting.

[0018] Unless specifically stated otherwise, as apparent from the following discussions, it is appreciated that throughout the specification discussions utilizing terms such as "processing", "computing", "calculating", "determining", "enhancing", "deriving" or the like, refer to the action and/or processes of a computer or computing system, or similar electronic computing device, that manipulates and/or transforms data represented as physical, such as electronic, quantities within the computing system's registers and/or memories into other data similarly represented as physical quantities within the

computing system's memories, registers or other such information storage, transmission or display devices.

[0019] Lithography systems and methods are provided with enhanced performance based on broader utilization of the integrated metrology tool in the printing tool to handle the metrology measurements in the system in a more sophisticated and optimized way. Additional operation channels are disclosed, enabling the integrated metrology tool to monitor and/or allocate metrology measurements thereby and by a standalone metrology tool with respect to specified temporal limitations of the printing tool; to adjust and optimize the metrology measurement recipes; to provide better process control to optimize process parameters of the printing tool; as well as to group process parameters of the printing tool according to a metrology measurements landscape.

[0020] **Figure 1** is a high level schematic block diagram illustration of lithography systems **70** according to the prior art. Current lithography systems **70** comprise a communication channel **115** between a printing tool **90** (e.g., a scanner, possibly a stepper, or any other printing tool) which connects a standalone metrology tool **80** to printing tool **90**. Standalone metrology tool **80** is configured to perform metrology measurements on wafers produced by printing tool **90**, e.g., to calculate corrections and provide feedback to printing tool **90**, based on metrology measurements by standalone metrology tool **80**. For example, in current practice, standalone metrology tool **80** is applied to measure several wafers per FOUP (front opening unified pod, e.g., 25 wafers) and calculate the scanner corrections required to meet the overlay budget. The corrections are then feedback to printing tool **90** to improve the overlay in its operation. Certain prior art configurations of printing tool **90** include an integrated metrology (IM) tool **95** configured to reduce the duration of the sampling for metrology measurements to meet scanner exposure time limitations. Integrated metrology tool **95** may be used in the prior art instead of or in addition to standalone metrology tool **80**.

[0021] **Figures 2-7** are high level schematic block diagram illustrations of lithography systems **100** according to some embodiments of the invention. **Figures 2-7** illustrate schematically multiple approaches, which may be combined in various ways to improve throughput and yield with respect to prior art lithography systems **70**. Elements from **Figures 2-7** may be combined in any operable combination, and the illustration of certain

elements in certain figures and not in others merely serves an explanatory purpose and is non-limiting. One or more processor(s) **112** may be used to implement any embodiment of control module **111** (see **Figure 7**). It is also noted that while the disclosure relates to one standalone metrology tool and one integrated metrology tool in the printing tool, disclosed systems and methods may just as well be applied to more complex systems with multiple metrology tools and/or printing tools.

[0022] Lithography systems **100** demonstrate several alternative and/or complementary ways to enhance performance by higher level integration and use of integrated metrology tool **95** with respect to multiple, independent and/or complementary requirements from lithography systems **100**. Disclosed lithography systems **100** may be configured to provide improved cycle time by reducing the reaction time to process excursions as well improve process accuracy by avoiding sampling reduction which is commonly required in prior art lithography systems **70** for meeting the scanner throughput, and may result in larger errors (e.g., larger residuals and required correction). As a result, disclosed lithography systems **100** may increase the process yield and reduce costs. In the following, potentially synergetic approaches and systems are disclosed for improving the monitoring of process excursions and process variations, improving the recipe optimization, improving the overlay accuracy and improving the Correction Per Exposure (CPE) rate.

[0023] **Figure 2** is a high level schematic block diagram illustrating lithography systems **100** with improved process tracking and metrology measurement analysis, according to some embodiments of the invention. Lithography systems **100** may be configured to have enhanced monitoring performance with respect to process excursions. In disclosed embodiments, a monitoring channel **110** may be established between a modified integrated metrology tool **105** and standalone metrology tool **80**, and a control module **111** in integrated metrology tool **105** may be configured to allocate to integrated metrology tool **105** and/or to standalone metrology tool **80** and to monitor the metrology measurements and the decision and allocation process. For example, a possible excursion can be detected by any of tracking the overlay, accuracy flags and/or any other parameter, by control module **111**, standalone metrology tool **80** and/or any other tool. In case an excursion is detected, control module **111** may be configured to hold printing tool **90** to

enable exposure for the suspected layer and decide to measure the overlay using integrated metrology tool **105**, via monitoring channel **110**, using standalone metrology tool **80**, for performing a more extensive analysis. Control module **111** and/or standalone metrology tool **80** may be further configured to detect, via monitoring channel **110**, process changes and adjust the metrology measurement recipe, using integrated metrology tool **105** within the scanner exposure time limitations. Therefore, monitoring channel **110** provides flexibility in the application of metrology measurement which provides both quick identification of excursion as well as means to accommodate the quality of the metrology measurements to specified scanner exposure time limitations or other requirements.

[0024] **Figures 3** and **4** are high level schematic block diagrams illustrating lithography systems **100** with recipe optimization at the level of integrated metrology tool **105**, according to some embodiments of the invention. In certain embodiments, integrated metrology tool **105** and/or control module **111** may be configured to perform recipe optimization and be configured to determine what scope of recipe optimization is required and to transfer, via a monitoring and optimization channel **120**, more extensive recipe optimizations to standalone metrology tool **80** and/or to transfer, via an optimization channel **130**, more extensive recipe optimizations to an additional metrology tool **135** or other external tools (e.g., simulation tools). Control module **111** may be configured to use integrated metrology tool **105** at a first phase of recipe optimization, e.g., to derive an overlay landscape as function of the wavelength and suggest optimal measurement parameters (e.g., the optimal wavelength, appetizer or other setups) - as disclosed in any of U.S. Application Publication No. 2016/0313658 and U.S. Application No. 15/329618, incorporated herein by reference in their entirety. It is noted that the landscape relates to an at least partially continuous dependency of at least one metrology metric (e.g., overlay for the overlay landscape) on at least one recipe parameter, by simulation or in preparatory measurements. The derived dependency may be used to relate metrology measurements and process parameters in an analytical way or by simulation. The optimal measurement parameters may then be transferred to standalone metrology tool **80** via monitoring and optimization channel **120**, and/or to additional

metrology tool **135** via optimization channel **130** - to optimize the performance of standalone metrology tool **80**, reduce cycle time and improve accuracy.

[0025] Figure 5 is a high level schematic block diagram illustrating of lithography systems **100** with improved process control, according to some embodiments of the invention. Systems **100** may comprise a process control channel **140** connecting integrated metrology tool **105** and/or control module **111** to provide input for process control software **60** (e.g., in a module which receives overlay data, optical critical dimensions (OCD) data, focus and dose data, etc. and uses the received data to improve the control over the process) and be used for improving process control outside the lithography cell. Possible processor(s) **112** associated with control module **111** may be configured to carry out at least part of process control software **60**. Integrated metrology tool **105** may be configured to derive any process parameter, such as the overlay, accuracy values, and other process parameters which may be useful for process control, and provide the process parameter(s) via process control channel **140** to process control software **60** for improving process control.

[0026] Figure 6 is a high level schematic block diagram illustrating of lithography systems **100** with landscape-based grouping, according to some embodiments of the invention. Systems **100** may comprise a grouping channel **150** connecting integrated metrology tool **105** and/or control module **111** to provide input for grouping of control, which is based on landscape information. The grouping may be carried out by a grouping module **170**, implemented externally and/or in any of integrated metrology tool **105**, control module **111** and standalone metrology tool **80**. System **100** may be configured to group control of any of wafers, chucks, processes, scanner operations, lithography or post lithography processes etc., according to metrology and/or process parameters (e.g., overlay, accuracy values or any process parameter) received through grouping channel **150** from integrated metrology tool **105** and/or control module **111**; and alternatively or complementarily, received through a grouping channel **155** from standalone metrology tool **80**. The grouping may be carried out by any processing unit, possibly even by control module **111**, and may be based on any landscape information or parameter, e.g., a wavelength signature, as disclosed in any of U.S. Application Publication No.

2016/0313658 and U.S. Application No. 15/329618, incorporated herein by reference in their entirety.

[0027] For example, integrated metrology tool **105** may be configured to provide a measure of the process shift with respect to a known calibrated state, such as the combination at t=0 of different process tools at their t=0 calibrated states, as a non-limiting example. Once process shifts are detected by integrated metrology tool **105**, the conditions of the process tools (e.g., printing tool **90**) may be modified gradually until they returns to their t=0 state. This may be achieved using feedback loop(s) between the metrology tool(s) **105**, **80** and multiple process tools (e.g., printing tool **90**).

[0028] In certain embodiments, the typical fingerprint of each process tool may be learned by metrology tools **105** and/or **80**, which may be configured to provide specific feedback(s) for each process tool.

[0029] **Figure 7** is a high level schematic block diagram illustrating of lithography systems **100** with various configurations of channels **110-150** disclosed above, according to some embodiments of the invention. Various disclosed embodiments comprise, in addition to prior art channel **85** between printing tool **90** and standalone metrology tool **80**, any of monitoring channel **110**, monitoring and optimization channel **120**, optimization channel **130**, process control channel **140** and/or grouping channel **150** and/or **155** disclosed above. Any combination thereof may be set as a configuration of disclosed lithography systems **100**.

[0030] **Figure 8** is a high level flowchart illustrating a method **200**, according to some embodiments of the invention. The method stages may be carried out with respect to lithography systems **100** described above, which may optionally be configured to implement method **200**. Method **200** may be at least partially implemented by at least one computer processor, e.g., in a metrology module. Certain embodiments comprise computer program products comprising a computer readable storage medium having computer readable program embodied therewith and configured to carry out the relevant stages of method **200**. Method **200** may comprise the following stages, irrespective of their order.

[0031] Method **200** may comprise monitoring (stage **210**) and/or allocating (stage **220**), by the integrated metrology tool of a lithography printing tool, metrology measurements

by the integrated metrology tool and a standalone metrology tool with respect to specified temporal limitations of the printing tool.

[0032] Method **200** may comprise adjusting and/or optimizing a metrology measurement recipe according to the specified temporal limitations (stage **230**).

[0033] Method **200** may further comprise optimizing process parameters of the printing tool by process control software, based on metrology measurements by at least the integrated metrology tool (stage **240**).

[0034] Method **200** may further comprise grouping process parameters of the printing tool according to a metrology measurements landscape (stage **250**).

[0035] Method **200** may further comprise deriving the metrology measurements landscape by at least the integrated metrology tool (stage **260**).

[0036] Aspects of the present invention are described above with reference to flowchart illustrations and/or portion diagrams of methods, apparatus (systems) and computer program products according to embodiments of the invention. It will be understood that each portion of the flowchart illustrations and/or portion diagrams, and combinations of portions in the flowchart illustrations and/or portion diagrams, can be implemented by computer program instructions. These computer program instructions may be provided to a processor of a general purpose computer, special purpose computer, or other programmable data processing apparatus to produce a machine, such that the instructions, which execute via the processor of the computer or other programmable data processing apparatus, create means for implementing the functions/acts specified in the flowchart and/or portion diagram or portions thereof.

[0037] These computer program instructions may also be stored in a computer readable medium that can direct a computer, other programmable data processing apparatus, or other devices to function in a particular manner, such that the instructions stored in the computer readable medium produce an article of manufacture including instructions which implement the function/act specified in the flowchart and/or portion diagram or portions thereof.

[0038] The computer program instructions may also be loaded onto a computer, other programmable data processing apparatus, or other devices to cause a series of operational steps to be performed on the computer, other programmable apparatus or other devices to

produce a computer implemented process such that the instructions which execute on the computer or other programmable apparatus provide processes for implementing the functions/acts specified in the flowchart and/or portion diagram or portions thereof.

[0039] The aforementioned flowchart and diagrams illustrate the architecture, functionality, and operation of possible implementations of systems, methods and computer program products according to various embodiments of the present invention. In this regard, each portion in the flowchart or portion diagrams may represent a module, segment, or portion of code, which comprises one or more executable instructions for implementing the specified logical function(s). It should also be noted that, in some alternative implementations, the functions noted in the portion may occur out of the order noted in the figures. For example, two portions shown in succession may, in fact, be executed substantially concurrently, or the portions may sometimes be executed in the reverse order, depending upon the functionality involved. It will also be noted that each portion of the portion diagrams and/or flowchart illustration, and combinations of portions in the portion diagrams and/or flowchart illustration, can be implemented by special purpose hardware-based systems that perform the specified functions or acts, or combinations of special purpose hardware and computer instructions.

[0040] In the above description, an embodiment is an example or implementation of the invention. The various appearances of "one embodiment", "an embodiment", "certain embodiments" or "some embodiments" do not necessarily all refer to the same embodiments. Although various features of the invention may be described in the context of a single embodiment, the features may also be provided separately or in any suitable combination. Conversely, although the invention may be described herein in the context of separate embodiments for clarity, the invention may also be implemented in a single embodiment. Certain embodiments of the invention may include features from different embodiments disclosed above, and certain embodiments may incorporate elements from other embodiments disclosed above. The disclosure of elements of the invention in the context of a specific embodiment is not to be taken as limiting their use in the specific embodiment alone. Furthermore, it is to be understood that the invention can be carried out or practiced in various ways and that the invention can be implemented in certain embodiments other than the ones outlined in the description above.

[0041] The invention is not limited to those diagrams or to the corresponding descriptions. For example, flow need not move through each illustrated box or state, or in exactly the same order as illustrated and described. Meanings of technical and scientific terms used herein are to be commonly understood as by one of ordinary skill in the art to which the invention belongs, unless otherwise defined. While the invention has been described with respect to a limited number of embodiments, these should not be construed as limitations on the scope of the invention, but rather as exemplifications of some of the preferred embodiments. Other possible variations, modifications, and applications are also within the scope of the invention. Accordingly, the scope of the invention should not be limited by what has thus far been described, but by the appended claims and their legal equivalents.

CLAIMS

What is claimed is:

1. A lithography system comprising:
 - a printing tool with an integrated metrology tool, and
 - a standalone metrology tool connected to the printing tool and configured to perform metrology measurements on wafers produced by the printing tool,
 - wherein the lithography system further comprises a monitoring channel connecting the integrated metrology tool with the standalone metrology tool, and the integrated metrology tool is further configured to allocate metrology measurements between the integrated metrology tool and the standalone metrology tool and monitor the allocation and the metrology measurement with respect to specified temporal limitations of the printing tool.
2. The lithography system of claim 1, wherein the monitoring comprises adjusting a metrology measurement recipe according to the specified temporal limitations.
3. The lithography system of claim 1, further comprising an optimization channel connecting the integrated metrology tool with a metrology tool configured to optimize a metrology measurement recipe for the lithography system
4. The lithography system of claim 1, wherein the metrology tool is the standalone metrology tool.
5. The lithography system of any one of claims 1-4, further comprising a process control channel connecting the integrated metrology tool with process control software configured to optimize process parameters of the printing tool.
6. The lithography system of any one of claims 1-5, further comprising a grouping channel connecting the integrated metrology tool with a grouping module configured to group process parameters of the printing tool according to a metrology measurements landscape.
7. The lithography system of any one of claims 1-6, further comprising a grouping channel connecting the standalone metrology tool with a grouping module configured to group process parameters of the printing tool according to a metrology measurements landscape.

8. The lithography system of claim 6 or 7, wherein the metrology measurements landscape is an at least partially continuous dependency of at least one metrology metric on at least one recipe parameter, derived by the respective metrology tool.
9. A method comprising allocating and monitoring, by an integrated metrology tool of a lithography printing tool, metrology measurements by the integrated metrology tool and a standalone metrology tool with respect to specified temporal limitations of the printing tool.
10. The method of claim 9, wherein the monitoring comprises adjusting (optimizing) a metrology measurement recipe according to the specified temporal limitations.
11. The method of claim 9 or 10, further comprising optimizing process parameters of the printing tool by process control software, based on metrology measurements by at least the integrated metrology tool.
12. The method of any one of claims 9-11, further comprising grouping process parameters of the printing tool according to a metrology measurements landscape.
13. The method of claim 12, further comprising deriving the metrology measurements landscape by at least the integrated metrology tool.
14. The method of any one of claims 9-13, carried out at least partly by a computer processor.
15. A computer program product comprising a non-transitory computer readable storage medium having computer readable program embodied therewith, the computer readable program configured to carry out the method of any one of claims 9-13.

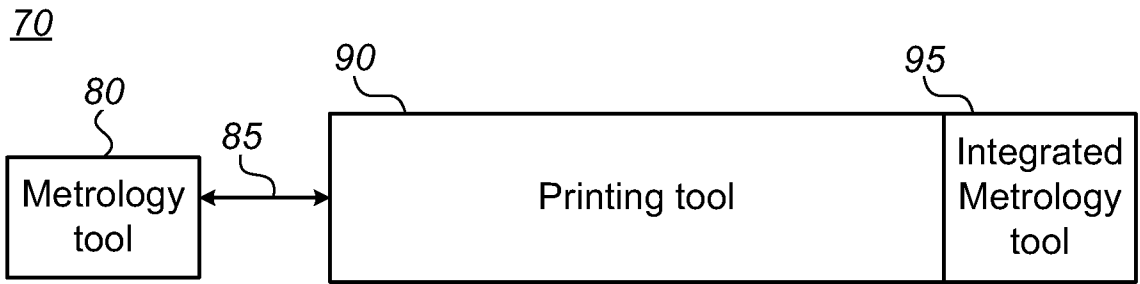

Figure 1 – Prior art

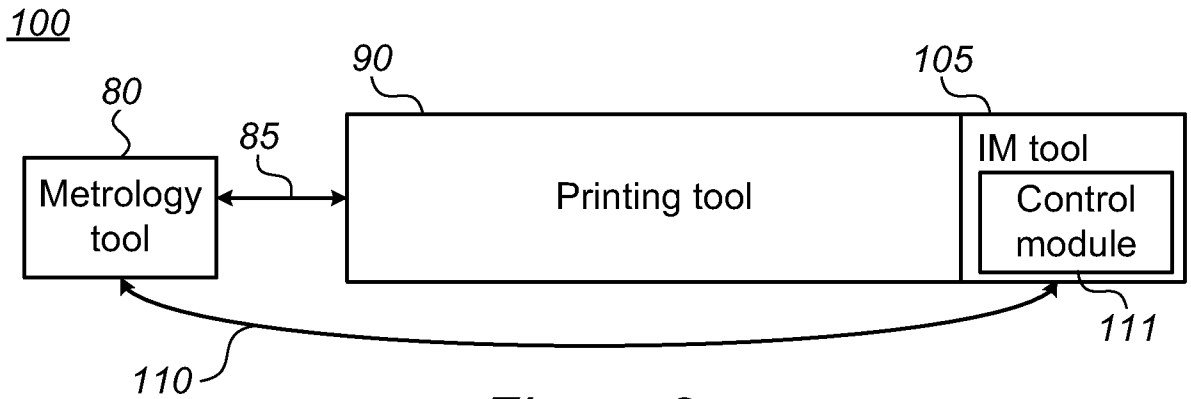

Figure 2

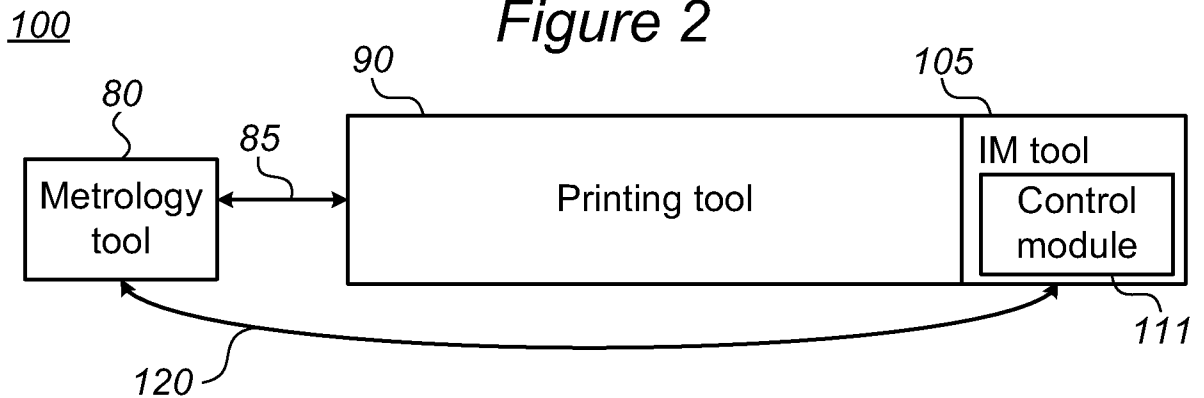

Figure 3

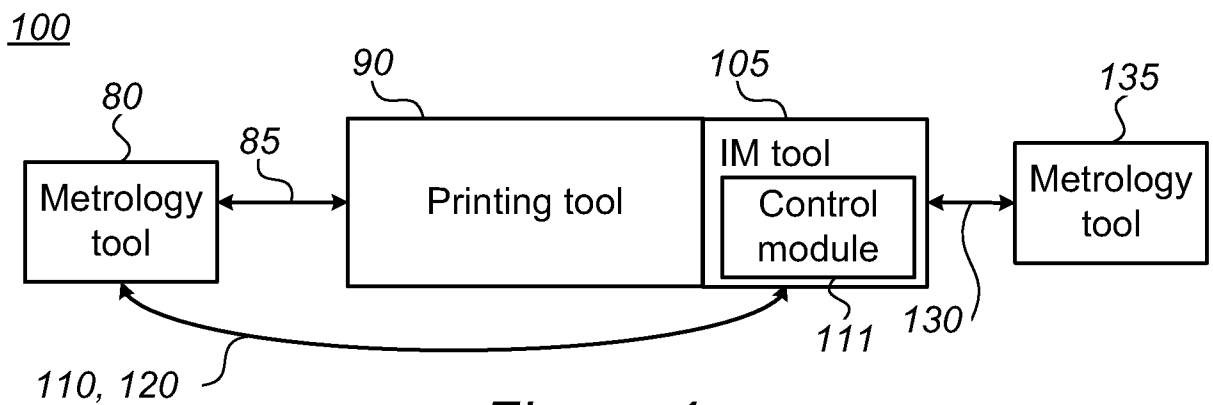

Figure 4

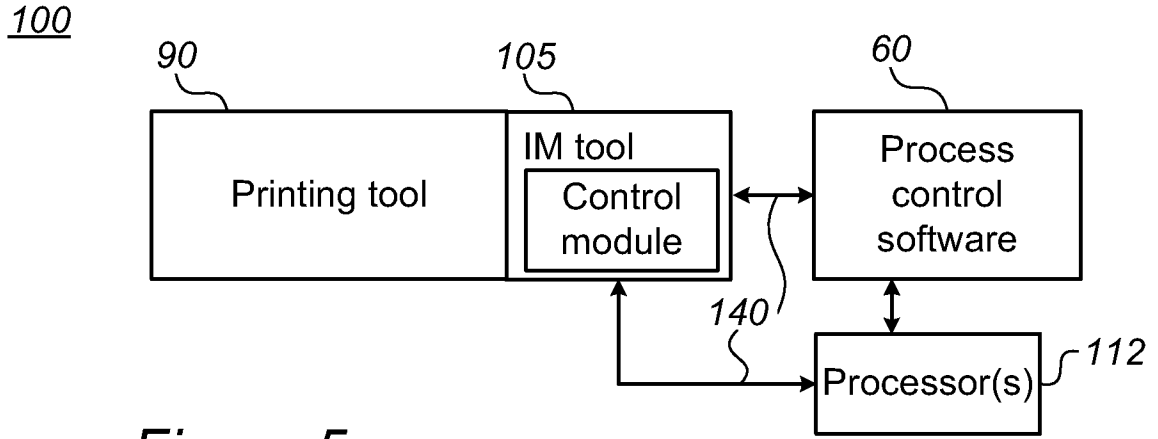

Figure 5

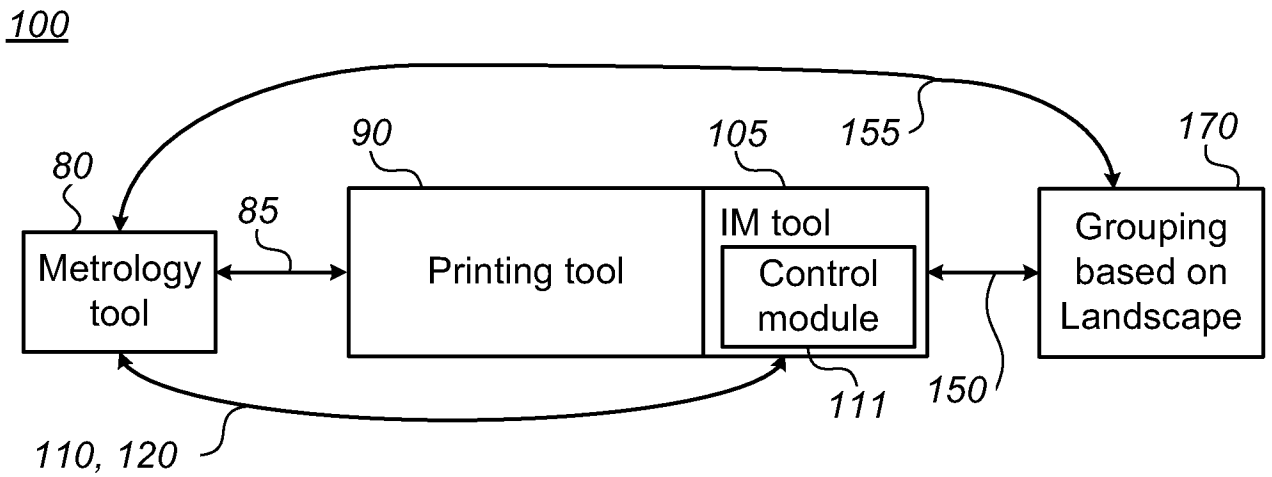

Figure 6

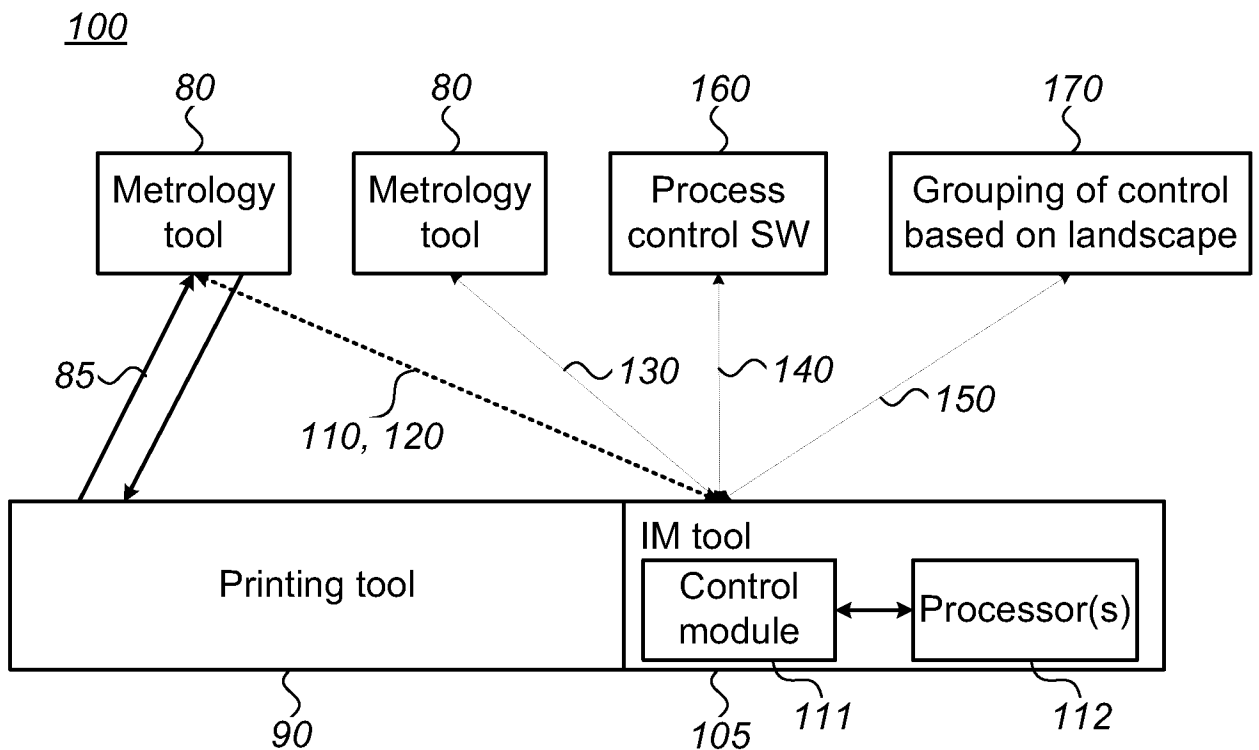

Figure 7

200

210 Monitoring, by the integrated metrology tool of a lithography printing tool, metrology measurements by the integrated and standalone metrology tools with respect to specified temporal limitations of the printing tool

220

Allocating, by the integrated metrology tool, metrology measurements thereby and by the standalone metrology tool with respect to specified temporal limitations of the printing tool

230

Adjusting and/or optimizing a metrology measurement recipe according to the specified temporal limitations

240

Optimizing process parameters of the printing tool by process control software, based on metrology measurements by at least the integrated metrology tool

250

Grouping process parameters of the printing tool according to a metrology measurements landscape

260

Deriving the metrology measurements landscape by at least the integrated metrology tool

Figure 8

A. CLASSIFICATION OF SUBJECT MATTER**G03F 7/20(2006.01)i, G03F 7/00(2006.01)i, H01L 21/027(2006.01)i**

According to International Patent Classification (IPC) or to both national classification and IPC

B. FIELDS SEARCHED

Minimum documentation searched (classification system followed by classification symbols)

G03F 7/20; H01L 21/027; G06F 19/00; G06F 17/50; G01B 11/14; G01N 21/95; H01L 21/66; H01J 37/317; G03F 7/00

Documentation searched other than minimum documentation to the extent that such documents are included in the fields searched

Korean utility models and applications for utility models

Japanese utility models and applications for utility models

Electronic data base consulted during the international search (name of data base and, where practicable, search terms used)

eKOMPASS(KIPO internal) & keywords: lithography system, printing tool, integrated metrology tool, standalone metrology tool, metrology measurement, monitoring channel, allocation, specified temporal limitation

C. DOCUMENTS CONSIDERED TO BE RELEVANT

Category*	Citation of document, with indication, where appropriate, of the relevant passages	Relevant to claim No.
A	US 6978189 B1 (BODE, C. A. et al.) 20 December 2005 See claims 1, 20.	1-5,9-11
A	US 2014-0354969 A1 (ASML NETHERLANDS B.V.) 04 December 2014 See paragraph [0413].	1-5,9-11
A	US 2014-0199791 A1 (KLA-TENCOR CORPORATION) 17 July 2014 See claims 1, 7.	1-5,9-11
A	US 2008-0027577 A1 (HORAK, D. V. et al.) 31 January 2008 See abstract; and claims 1, 10.	1-5,9-11
A	WO 2014-074868 A1 (KLA-TENCOR CORPORATION) 15 May 2014 See paragraph [0026]; claim 1; and figure 1C.	1-5,9-11

 Further documents are listed in the continuation of Box C. See patent family annex.

* Special categories of cited documents:

"A" document defining the general state of the art which is not considered to be of particular relevance

"E" earlier application or patent but published on or after the international filing date

"L" document which may throw doubts on priority claim(s) or which is cited to establish the publication date of another citation or other special reason (as specified)

"O" document referring to an oral disclosure, use, exhibition or other means

"P" document published prior to the international filing date but later than the priority date claimed

"T" later document published after the international filing date or priority date and not in conflict with the application but cited to understand the principle or theory underlying the invention

"X" document of particular relevance; the claimed invention cannot be considered novel or cannot be considered to involve an inventive step when the document is taken alone

"Y" document of particular relevance; the claimed invention cannot be considered to involve an inventive step when the document is combined with one or more other such documents, such combination being obvious to a person skilled in the art

"&" document member of the same patent family

Date of the actual completion of the international search

28 November 2017 (28.11.2017)

Date of mailing of the international search report

28 November 2017 (28.11.2017)

Name and mailing address of the ISA/KR

International Application Division
Korean Intellectual Property Office
189 Cheongsa-ro, Seo-gu, Daejeon, 35208, Republic of Korea

Facsimile No. +82-42-481-8578

Authorized officer

KIM, Sun Hee

Telephone No. +82-42-481-5405

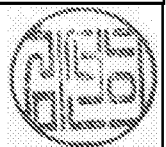

Box No. II Observations where certain claims were found unsearchable (Continuation of item 2 of first sheet)

This international search report has not been established in respect of certain claims under Article 17(2)(a) for the following reasons:

1. Claims Nos.:
because they relate to subject matter not required to be searched by this Authority, namely:

2. Claims Nos.: 13
because they relate to parts of the international application that do not comply with the prescribed requirements to such an extent that no meaningful international search can be carried out, specifically:
Claim 13 is unclear since it refers to claim which is not searchable due to not being drafted in accordance with a third sentence of Rule 6.4(a).

3. Claims Nos.: 6-8, 12, 14-15
because they are dependent claims and are not drafted in accordance with the second and third sentences of Rule 6.4(a).

Box No. III Observations where unity of invention is lacking (Continuation of item 3 of first sheet)

This International Searching Authority found multiple inventions in this international application, as follows:

1. As all required additional search fees were timely paid by the applicant, this international search report covers all searchable claims.

2. As all searchable claims could be searched without effort justifying an additional fees, this Authority did not invite payment of any additional fees.

3. As only some of the required additional search fees were timely paid by the applicant, this international search report covers only those claims for which fees were paid, specifically claims Nos.:

4. No required additional search fees were timely paid by the applicant. Consequently, this international search report is restricted to the invention first mentioned in the claims; it is covered by claims Nos.:

Remark on Protest

- The additional search fees were accompanied by the applicant's protest and, where applicable, the payment of a protest fee.
- The additional search fees were accompanied by the applicant's protest but the applicable protest fee was not paid within the time limit specified in the invitation.
- No protest accompanied the payment of additional search fees.

INTERNATIONAL SEARCH REPORT

Information on patent family members

International application No.

PCT/US2017/047742

Patent document cited in search report	Publication date	Patent family member(s)	Publication date
US 6978189 B1	20/12/2005	None	
US 2014-0354969 A1	04/12/2014	KR 10-1705275 B1 KR 10-2014-0083055 A KR 10-2017-0018097 A NL 2009853 A US 2017-0160073 A1 US 9594029 B2 WO 2013-092106 A1	09/02/2017 03/07/2014 15/02/2017 26/06/2013 08/06/2017 14/03/2017 27/06/2013
US 2014-0199791 A1	17/07/2014	US 9576861 B2 WO 2014-081897 A1	21/02/2017 30/05/2014
US 2008-0027577 A1	31/01/2008	US 2006-0007453 A1 US 7289864 B2 US 7502660 B2	12/01/2006 30/10/2007 10/03/2009
WO 2014-074868 A1	15/05/2014	TW 201428418 A US 2014-0141536 A1 US 9454072 B2	16/07/2014 22/05/2014 27/09/2016