



(11) **EP 1 736 588 B1**

(12) **EUROPEAN PATENT SPECIFICATION**

(45) Date of publication and mention of the grant of the patent:
23.01.2008 Bulletin 2008/04

(51) Int Cl.:
D06F 37/08^(2006.01) D06F 37/06^(2006.01)
D06F 58/04^(2006.01)

(21) Application number: **05105537.4**

(22) Date of filing: **22.06.2005**

(54) **Laundry dryer with pliable drum dividing member**

Wäschetrockner mit biegsamer Trommel-Trennwand

Sèche-linge avec cloison pliable du tambour

(84) Designated Contracting States:
AT BE BG CH CY CZ DE DK EE ES FI FR GB GR HU IE IS IT LI LT LU MC NL PL PT RO SE SI SK TR

(43) Date of publication of application:
27.12.2006 Bulletin 2006/52

(73) Proprietor: **Electrolux Home Products Corporation N.V.**
1930 Zaventem (BE)

(72) Inventor: **Arreghini, Luigi**
30026 Portogruaro (IT)

(74) Representative: **Giugni, Valter et al**
PROPRIA S.r.l.
P.O. Box 365
Via della Colonna, 35
33170 Pordenone (IT)

(56) References cited:
EP-A- 1 405 945 US-A- 2 298 352
US-A- 3 738 129 US-A- 3 938 260
US-A1- 2002 092 329

- **PATENT ABSTRACTS OF JAPAN vol. 2003, no. 12, 5 December 2003 (2003-12-05) -& JP 2004 097317 A (TOSEI DENKI KK), 2 April 2004 (2004-04-02)**

EP 1 736 588 B1

Note: Within nine months from the publication of the mention of the grant of the European patent, any person may give notice to the European Patent Office of opposition to the European patent granted. Notice of opposition shall be filed in a written reasoned statement. It shall not be deemed to have been filed until the opposition fee has been paid. (Art. 99(1) European Patent Convention).

Description

[0001] The present invention refers to a laundry dryer.

[0002] It may be necessary to keep different type of articles to be dried effectively separated in the drum and to confine such articles in reduced spaces, with respect to the volume of the drum, in order to minimize mechanical stress caused by the movement of the drum. Further, there is the need for limiting the movement of articles during the drying operation and for preventing articles to be dried to come into contact with the drum.

[0003] This may be the case, for example, with knitwear and woollens, which would shrink if, they exceedingly moved during drying. The same may apply to shoes or other items for drying that could be damaged by the movement in the drum.

[0004] Also well known are the drawbacks of using rotary laundry dryers to dry footwear, i.e. the loud thumping and banging noises normally generated by placing relatively hard footwear in the rotating drum of a laundry dryer.

[0005] US 3,738,129 discloses a drum for washing and dry-cleaning machines comprising a displaceable textile web partition in form of a strip of fabric, netting or the like loosely suspended in the drum, having a length greater than the diameter of the drum and having its opposite end portions secured to the drum at transversely spaced locations at opposite sides of the axis of rotation of the drum in order to partition the interior of the drum into a plurality of compartments each accessible via the entire cross-sectional area of the drum access opening.

[0006] The aim of the present invention is therefore to provide a laundry dryer having a drum in which it is possible to effectively keep separated, inside the drum, different kinds of articles to be dried.

[0007] It is an object of the present invention to provide a laundry dryer having a drum in which it is possible to confine delicate articles into separate compartments of reduce volumes, with respect to the volume of the drum, in order to limit the movement of the articles and to reliably avoid damages to such articles during the drying operation.

[0008] It is a further object to provide a laundry drier having a drum in which it is possible, in the same load, to keep shoes separate from any more delicate articles of clothing therefore preventing their entanglement and damage.

[0009] It is a further object to provide a laundry drier having a drum in which it is possible to encapsulate shoes to allow them to be effectively dried reducing loud thumping and banging noises.

[0010] It is a further object to provide a laundry drier having a drum in which it is possible to prevent articles to be dried to come into contact with the drum during the drying operation.

[0011] According to the present invention, this aim is reached in a laundry dryer having the characteristics as recited and defined in the appended claims.

[0012] The invention, illustrated and described herein, it is not intended to be limited to the details shown because obvious modifications and structural changes may be made with respect to the preferred embodiment hereinafter described, provided that such modifications and changes fall within the scope of the appended claims.

[0013] Anyway, features and advantages of the present invention may be more readily understood from the description that is given below by way of a nonlimiting example with reference to the accompanying drawings, in which:

- Figure 1 is a front elevational view of a drum of a laundry drier, according to the present invention;
- Figure 2 is a front elevational view of a drum of a laundry drier, according to a further embodiment of the present invention;
- Figure 3 is an enlarged detailed view of a lifter, according to the present invention;
- Figure 4 is an enlarged detailed view of a lifter, according to the present invention.

[0014] With reference to the figures, the laundry dryer, according to the present invention, comprises a rotatable drum, generally designated by the reference numerical 1, with at least a lifter 2 for moving the laundry as the drum rotates. The lifter 2 is adapted to house a winding mechanism 3 for a pliable member 4 to be wound and unwound, the pliable member 4 is slidably changeable from a first position, in which the pliable member 4 is contained inside the lifter 2, to a second position, in which the pliable member 4 extends into the drum 1 and is adapted to be associated with the drum 1 so as to divide the latter into separate compartments.

[0015] The laundry dryer is provided, as known in the art, with a fan, a heater, and an air circuit, in order to direct a heated airflow into the drum, through perforations thereof. The airflow, flowing into the drum, comes into contact there with the laundry that is to be dried, so that moisture in the laundry is absorbed by the air by cooling and it is condensed and discharged. The air circuit can form a closed loop with the drum or an air circuit opened to the atmosphere.

[0016] Referring now to the figures of the drawings in detail, the laundry dryer comprises a drum 1 that can be rotated around a longitudinal axis and within which at least one lifter 2 is provided for moving the laundry as the drum rotates. The lifter 2 extends longitudinally on the internal surface of the drum 1, substantially along the entire longitudinal dimension of the drum 1. The lifter 2 can be fastened to the drum 1 by means of screws, rivet or other equivalent clamping means, but in a further embodiment the lifter 2 can be formed integrally in one piece with the drum 1.

[0017] The lifter 2 comprises a V shaped shell with the

apex facing onto the inner portion of the drum 1. The lifter 2 is adapted to form with the drum 1 a cavity 5 defining a housing for the winding mechanism 3. The winding mechanism 3 comprises a roll support or reel 6 arranged in the cavity 5 for the pliable member 4 to be wound and unwound. A first end edge of the pliable member 4 is associated with the reel 6, and the latter is biased by appropriate spring means so as to keep the pliable member 4 in the first position, in which the pliable member 4 is completely wound around the reel 6 inside the V shaped shell of the lifter 2 and so as to automatically rewind the pliable member 4 when the latter is unwound and extends into the drum 1 in the second position.

[0018] The V shaped shell of the lifter 2 comprises a longitudinal slot 7, which the pliable member 4 is adapted to pass through for being slidably changeable between the first and the second position.

[0019] A free end edge of the pliable member 4 is associated with a clamping body 8 adapted to be arranged in correspondence to a first seat 9, which is provided on the V shaped shell of the lifter 2, when the pliable member 4 is wound around the reel 6 and contained inside the lifter 2, in the first position.

[0020] The pliable member 4 is adapted to be unwound from the first position to the second position by means of the clamping body 8, which can be easily handled by a user.

[0021] In a first embodiment of the present invention, the clamping body 8 is adapted to be removably fastened directly to the internal surface of the drum 1. Projections (not shown) can be provided on the clamping body 8 in order to engage the perforations of the drum 1. Clearly other type of fastening can be envisaged.

[0022] In a second preferred embodiment, the clamping body 8 is adapted to be removably fastened to a further lifter 2, according to the present invention, associated with the drum 1. Advantageously the V shaped shell of the lifter 2 is provided externally with a second seat 10 adapted to receive and locked in position the clamping body 8, as shown in figure 2 and 3.

[0023] The pliable member 4, fastened to the drum 1 or to the lifter 2, is adapted to divide the drum 1 into separate compartments so as to keep articles to be dried effectively separated, and to confine articles in reduced spaces, thereby minimizing mechanical stress caused by the movement of the drum 1.

[0024] When there is no longer need for separate compartments, the clamping body 8 is adapted to be disengaged from the second seat 10 of the lifter 2, and the pliable member 4 is adapted to be automatically rewound around the reel 6, inside the V shaped shell of the lifter 2, by means of the winding mechanism 3.

[0025] In a most preferred embodiment, the drum 1 comprises three lifter 2, according to the present invention, in order to define a triangular enclosed chamber adapted to encapsulate items to be dried and to prevent the latter to come into contact with the drum 1, as shown in figure 2.

[0026] The pliable member 4 is preferably made of an air-permeable material, such as in the case of a web, net, or a mesh or it can be made of plastic material provided with openings.

5 **[0027]** Conclusively, it can therefore be stated that the laundry dryer, according to the present invention, allows to effectively keep separated, inside the drum, different kinds of articles to be dried, and to confine delicate articles into separate compartments of reduced volume so as to limit the movement of the articles and to reliably avoid damage to such articles during the drying operation.

10 **[0028]** Further, it can be stated that the apparatus, according to the present invention, is simple in construction, light in weight, occupies minimum of the useful space of the dryer, is easy to use, simple to manufacture, reliable in operation, does not damage the drum, and allows efficient utilization of the drying drum's lifter as additional supports for objects being dried.

15 **[0029]** Although the above description and drawings contains many specificities, these should not be construed as limiting the scope of the invention but as merely providing illustrations of some of the presently preferred embodiments of this invention.

20

25

Claims

1. Laundry dryer comprising a rotatable drum (1) with at least a lifter (2) for moving the laundry as the drum (1) rotates and a pliable member (4) for dividing the drum (1) into separate compartments, **characterized in that** said lifter (2) is adapted to house a winding mechanism (3) for said pliable member (4) to be wound and unwound, said pliable member (4) being slidably changeable from a first position, in which the pliable member (4) is contained inside said lifter (2), to a second position, in which the pliable member (4) extends into the drum (1) and is adapted to be associated with said drum (1) so as to divide the latter into separate compartments.
2. Laundry dryer according to claim 1, **characterized in that** said pliable member (4) is adapted to be removably fastened to an internal surface of the drum (1).
3. Laundry dryer according to claim 1, **characterized in that** said pliable member (4) is adapted to be removably fastened to at least one of said lifter (2).
4. Laundry dryer according to claim 1, **characterized in that** said lifter (2) is adapted to form with the drum (1) a cavity (5) defining an housing for the winding mechanism (3).
5. Laundry dryer according to claim 4, **characterized in that** said winding mechanism (3) comprises a roll

support or reel (6) arranged in the cavity (5) for the pliable member (4) to be wound and unwound

6. Laundry dryer according to claim 5, **characterized in that** said reel (6) is biased by spring means so as to keep the pliable member (4) in the first position, in which the pliable member (4) is completely wound around the reel (6) inside the lifter (2) and so as to automatically rewind the pliable member (4) when the latter is unwound and extends into the drum (1) in the second position.
7. Laundry dryer according to any of the preceding claims, **characterized in that** said lifter (2) comprises a longitudinal slot (7) which the pliable member (4) is adapted to pass through for being slidably changeable between the first and the second position.
8. Laundry dryer according to any of the preceding claims 5 or 6, or 7 in combination with claim 5 or 6, **characterized in that** a free end edge of the pliable member (4) is associated with a clamping body (8) adapted to be arranged in correspondence to a first seat (9), provided on the lifter (2), when the pliable member 4 is wound around the reel (6) and contained inside the lifter (2), in the first position.
9. Laundry dryer according claim 8, **characterized in that** said clamping body (8) is adapted to be removably fastened to the internal surface of the drum (1).
10. Laundry dryer according to claim 9, **characterized in that** projections are provided on the clamping body (8) in order to engage perforations of the drum (1).
11. Laundry dryer according to claim 8, **characterized in that** said clamping body (8) is adapted to be removably fastened to at least one of said lifter (2).
12. Laundry dryer according to claim 11, **characterized in that** said lifter (2) is provided with a second seat (10) adapted to receive and lock in position the clamping body (8).
13. Laundry dryer according to any of the preceding claims, **characterized in that** said drum (1) comprises three of said at least a lifter (2) in order to define a triangular enclosed chamber adapted to encapsulate items to be dried and to prevent the latter to come into contact with the drum (1).

Patentansprüche

1. Wäschetrockner, der eine rotierbare Trommel (1) mit mindestens einem Heber (2), der die Wäsche wäh-

rend der Rotation der Trommel (1) bewegt, und einem biegsamen Element (4) zur Unterteilung der Trommel (1) in getrennte Abschnitte umfasst, **dadurch gekennzeichnet, dass** der Heber (2) geeignet ist, einen Wickelmechanismus (3) für das auf- und abzuwickelnde biegsame Element (4) aufzunehmen, welches verschiebbar von einer ersten Position, in der das biegsame Element (4) innerhalb des Hebers (2) angeordnet ist, in eine zweite Position gewechselt werden kann, in der sich das biegsame Element (4) in die Trommel (1) hinein erstreckt und mit der Trommel (1) verbunden werden kann, um diese in getrennte Fächer zu unterteilen.

5

10

15

20

25

30

35

40

45

50

55

2. Wäschetrockner gemäß Anspruch 1, **dadurch gekennzeichnet, dass** das biegsame Element (4) geeignet ist, abnehmbar an einer innenfläche der Trommel (1) befestigt zu werden.

3. Wäschetrockner gemäß Anspruch 1, **dadurch gekennzeichnet, dass** das biegsame Element (4) geeignet ist, an mindestens einem der Heber (2) abnehmbar befestigt zu werden.

4. Wäschetrockner gemäß Anspruch 1, **dadurch gekennzeichnet, dass** der Heber (2) geeignet ist, mit der Trommel (1) einen Hohlraum (5) zu bilden, der ein Gehäuse für den Wickelmechanismus (3) definiert.

5. Wäschetrockner gemäß Anspruch 4, **dadurch gekennzeichnet, dass** der Wickelmechanismus (3) einen Rollenträger bzw. eine Spule (6) umfasst, die im Hohlraum (5) für das auf- und abzuwickelnde biegsame Element (4) angeordnet ist.

6. Wäschetrockner gemäß Anspruch 5, **dadurch gekennzeichnet, dass** die Spule (6) durch Federmittel gespannt ist, um das biegsame Element (4) in der ersten Position zu halten, in der das biegsame Element (4) vollkommen um die Spule (6) innerhalb des Hebers (2) gewickelt ist, und um das biegsame Element (4) automatisch aufzuwickeln, wenn dieses in der zweiten Position abgewickelt ist und sich in die Trommel (1) hinein erstreckt.

7. Wäschetrockner gemäß einem der vorangehenden Ansprüche, **dadurch gekennzeichnet, dass** der Heber (2) einen Längsschlitz (7) umfasst, durch den das biegsame Element (4) hindurch zu gehen vermag, um verschiebbar zwischen der ersten und zweiten Position gewechselt zu werden.

8. Wäschetrockner gemäß einem der vorangehenden Ansprüche 5 oder 6 oder 7 in Kombination mit Anspruch 5 oder 6, **dadurch gekennzeichnet, dass** eine freie Endkante des biegsamen Elements (4) mit einem Spannkörper (8) verbunden ist, der in Ent-

sprechung zu einem auf dem Heber (2) vorgesehenen ersten Sitz (9) angeordnet werden kann, wenn das biegsame Element (4) um die Spule (6) gewickelt und innerhalb des Hebers (2) in der ersten Position angeordnet ist.

9. Wäschetrockner gemäß Anspruch 8, **dadurch gekennzeichnet, dass** der Spannkörper (8) geeignet ist, abnehmbar an der Innenfläche der Trommel (1) befestigt zu werden.
10. wäschetrockner gemäß Anspruch 9, **dadurch gekennzeichnet, dass** am Spannkörper (8) Vorsprünge angebracht sind, um in die Perforationen der Trommel (1) einzugreifen.
11. Wäschetrockner gemäß Anspruch 8, **dadurch gekennzeichnet, dass** der Spannkörper (8) an mindestens einem Heber (2) abnehmbar befestigt werden kann.
12. Wäschetrockner gemäß Anspruch 11, **dadurch gekennzeichnet, dass** der Heber (2) mit einem zweiten Sitz (10) ausgestattet ist, der geeignet ist, den Spannkörper (8) aufzunehmen und zu fixieren.
13. Wäschetrockner gemäß einem der vorangehenden Ansprüche, **dadurch gekennzeichnet, dass** die Trommel (1) drei der mindestens einen Heber (2) umfasst, um eine dreieckige, geschlossene Kammer zu definieren, die geeignet ist, zu trocknende Gegenstände einzuschließen und zu verhindern, dass diese in Kontakt mit der Trommel (1) geraten.

Revendications

1. Sèche-linge comprenant un tambour rotatif (1) avec au moins un élévateur (2) pour déplacer le linge quand le tambour (1) tourne et un élément souple (4) pour diviser le tambour (1) en des compartiments séparés, **caractérisé en ce que** ledit élévateur (2) est adapté pour recevoir un mécanisme enrouleur (3) pour enrouler et dérouler ledit élément souple (4), ledit élément souple (4) pouvant être passé par coulissement d'une première position dans laquelle l'élément souple (4) est contenu à l'intérieur dudit élévateur (2) à une deuxième position dans laquelle l'élément souple (4) s'étend dans le tambour (1) et est adapté pour être associé audit tambour (1) afin de diviser ce dernier en des compartiments séparés.
2. Sèche-linge selon la revendication 1, **caractérisé en ce que** ledit élément souple (4) est adapté pour être fixé de manière amovible à une surface intérieure du tambour (1).
3. Sèche-linge selon la revendication 1, **caractérisé**

en ce que ledit élément souple (4) est adapté pour être fixé de manière amovible audit élévateur (2) au nombre d'au moins un.

- 5 4. Sèche-linge selon la revendication 1, **caractérisé en ce que** ledit élévateur (2) est adapté pour former avec le tambour (1) une cavité (5) définissant un logement pour le mécanisme enrouleur (3).
- 10 5. sèche-linge selon la revendication 4, **caractérisé en ce que** ledit mécanisme enrouleur (3) comprend un support à rouleau ou une bobine (6), placé dans la cavité (5) pour enrouler et dérouler l'élément souple (4).
- 15 6. Sèche-linge selon la revendication 5, **caractérisé en ce que** ladite bobine (6) est poussée par des moyens à ressort afin de maintenir l'élément souple (4) dans la première position, dans laquelle l'élément souple (4) est complètement enroulé autour de la bobine (6) à l'intérieur de l'élévateur (2) et de manière à rembobiner automatiquement l'élément souple (4) quand ce dernier est déroulé et s'étend dans le tambour (1) dans la deuxième position.
- 20 7. Sèche-linge selon l'une des revendications précédentes, **caractérisé en ce que** ledit élévateur (2) comprend une fente longitudinale (7) que l'élément souple (4) est adapté à traverser pour pouvoir passer par coulissement de la première à la deuxième positions.
- 30 8. Sèche-linge selon l'une des revendications précédentes 5 ou 6, ou 7 en liaison avec la revendication 5 ou 6, **caractérisé en ce qu'**un bord d'extrémité libre de l'élément souple (4) est associé à un corps de serrage (8) adapté pour être placé en correspondance d'un premier siège (9) prévu sur l'élévateur (2) quand l'élément souple (4) est enroulé autour de la bobine (6) et contenu dans l'élévateur (2) dans la première position.
- 35 9. Sèche-linge selon la revendication 8, **caractérisé en ce que** ledit corps de serrage (8) est adapté pour être fixé de manière amovible à la surface interne du tambour (1).
- 40 10. Sèche-linge selon la revendication 9, **caractérisé en ce que** des saillies sont prévues sur le corps de serrage (8) pour s'engager dans des perforations du tambour (1).
- 45 11. Sèche-linge selon la revendication 8, **caractérisé en ce que** le corps de serrage (8) est adapté pour être fixé de manière amovible audit élévateur (2) au nombre d'au moins un.
- 50 12. Sèche-linge selon la revendication 11, **caractérisé**

en ce que ledit élévateur **(2)** est muni d'un second siège (10) adapté pour recevoir et verrouiller en position le corps de serrage **(8)**.

13. Sèche-linge selon l'une des revendications précédentes, **caractérisé en ce que** ledit tambour **(1)** comprend trois élévateurs **(2)** au nombre d'au moins un pour définir une chambre triangulaire fermée, adaptée pour renfermer les articles à sécher et empêcher ces derniers d'entrer en contact avec le tambour **(1)**.

5

10

15

20

25

30

35

40

45

50

55

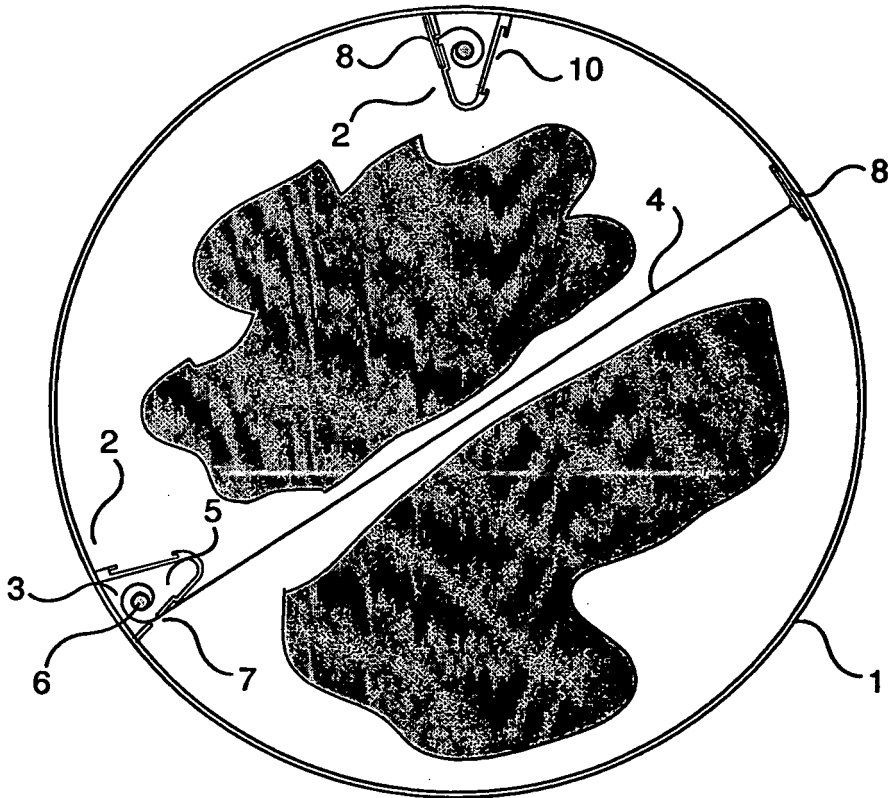

fig 1

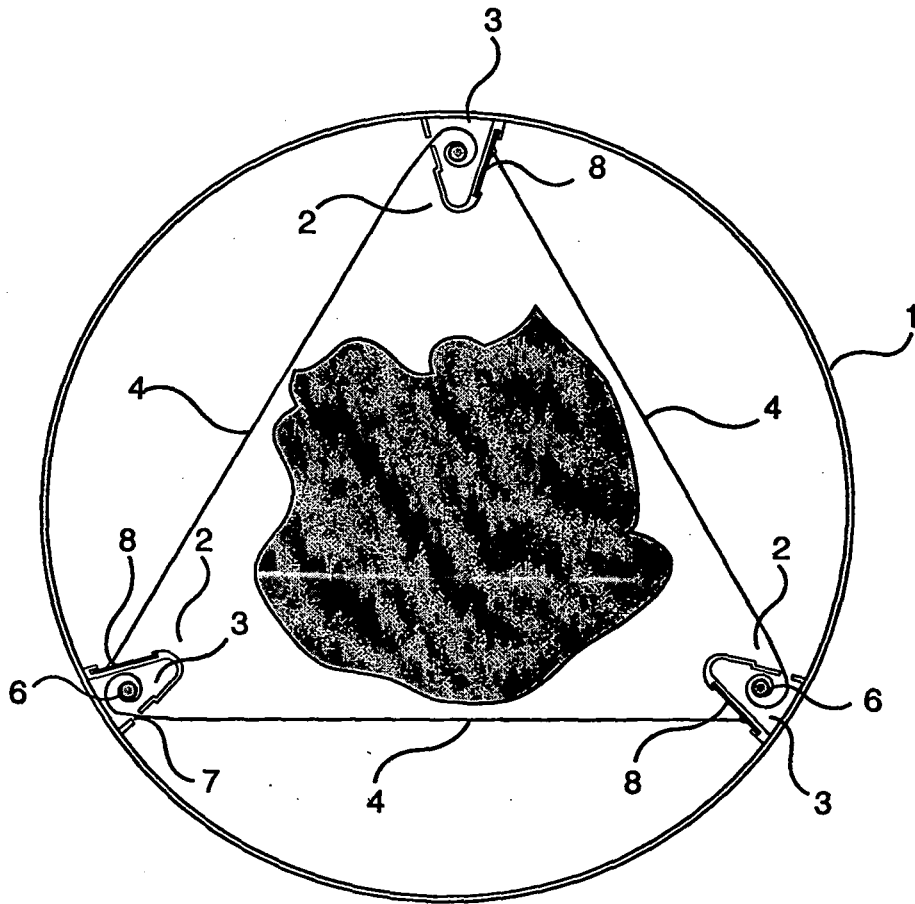

fig 2

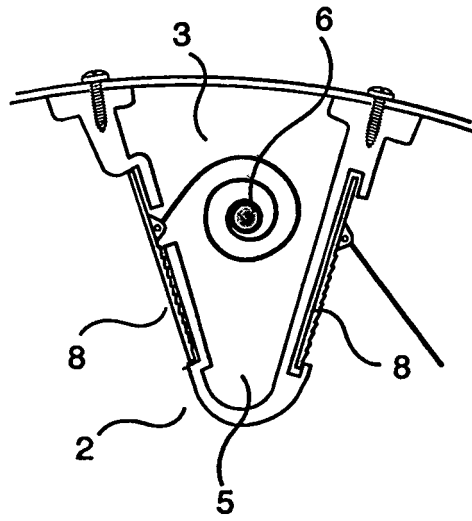

FIG 3

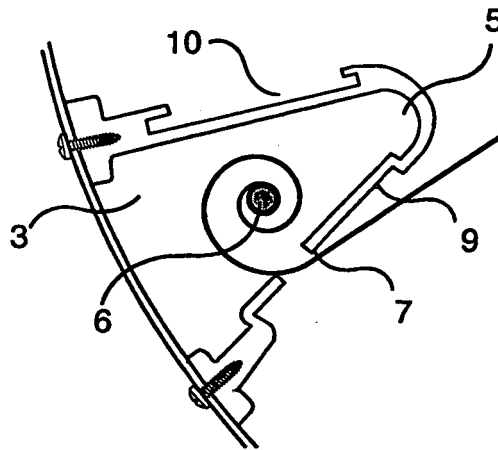

FIG 4

REFERENCES CITED IN THE DESCRIPTION

This list of references cited by the applicant is for the reader's convenience only. It does not form part of the European patent document. Even though great care has been taken in compiling the references, errors or omissions cannot be excluded and the EPO disclaims all liability in this regard.

Patent documents cited in the description

- US 3738129 A [0005]