

Dec. 2, 1941.

I. DU B. SMITH ET AL
REFRIGERATING APPARATUS

2,265,084

Filed Oct. 11, 1940

2 Sheets-Sheet 1

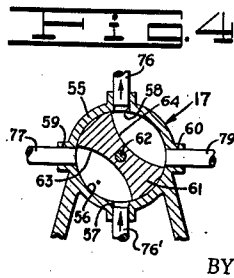
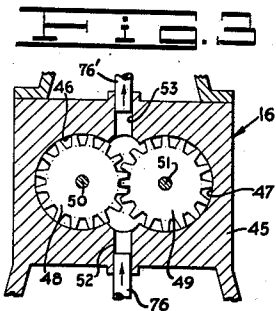
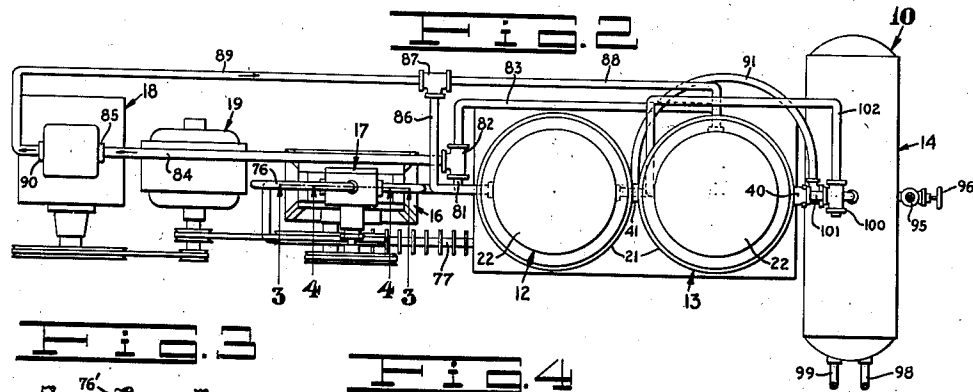
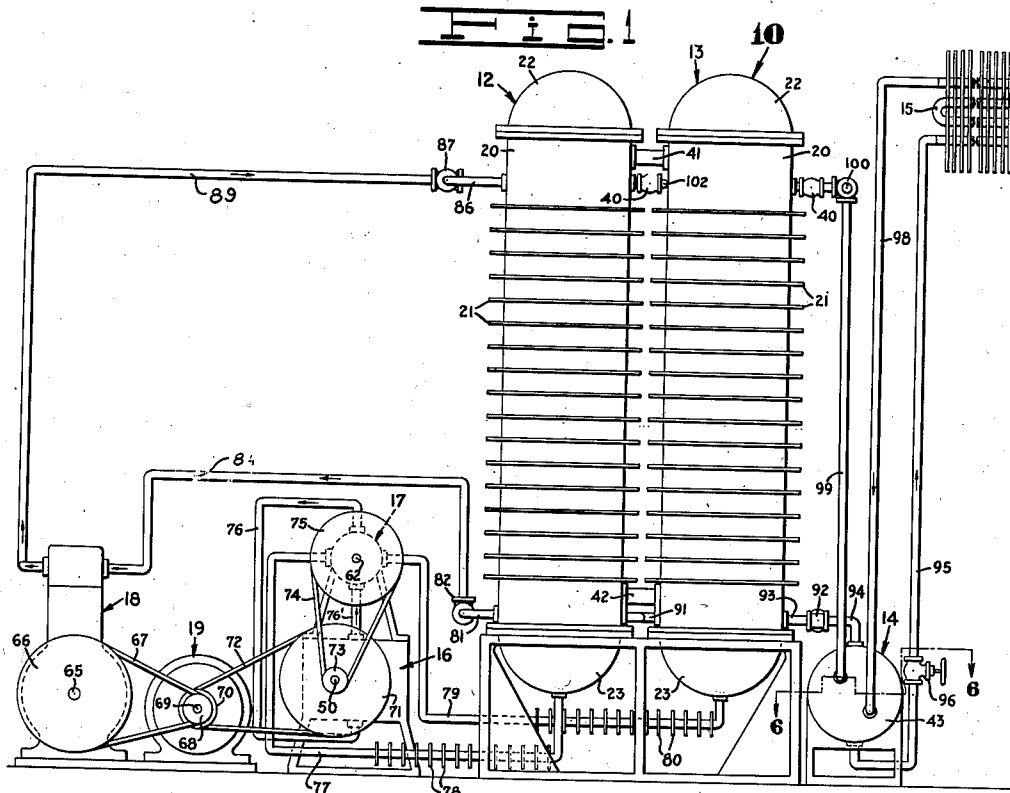

INVENTORS.
Conrad R. Buchet.
Ian DuBois Smith.

BY *B. Craig*
ATTORNEY.

Dec. 2, 1941.

I. DU B. SMITH ET AL
REFRIGERATING APPARATUS

2,265,084

Filed Oct. 11, 1940

2 Sheets-Sheet 2

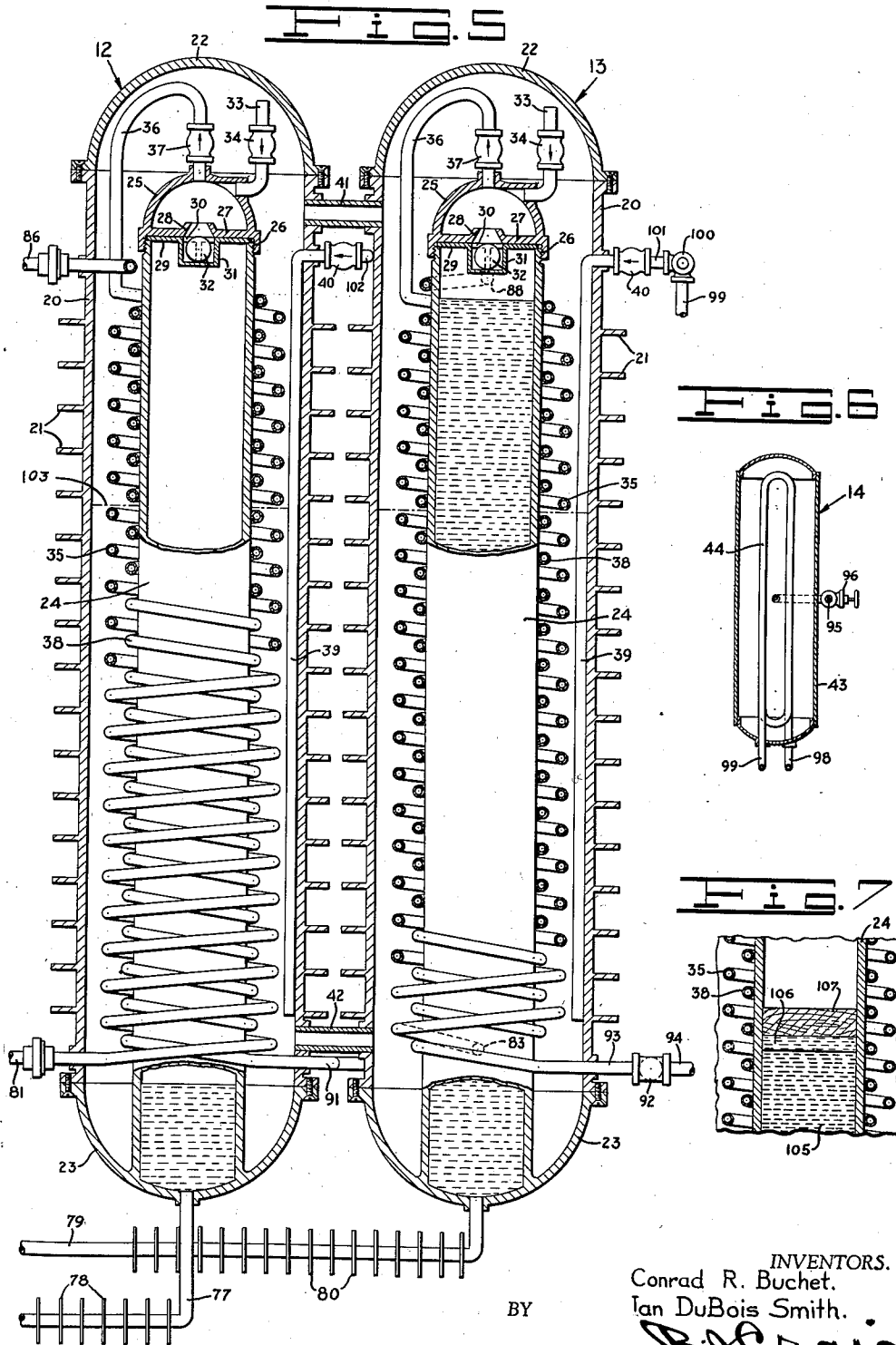

INVENTORS.
Conrad R. Buchet.
Ian DuBois Smith.

Craig
ATTORNEY.

UNITED STATES PATENT OFFICE

2,265,084

REFRIGERATING APPARATUS

Ian Du Bois Smith, South Pasadena, and Conrad
Robert Buchet, Los Angeles, Calif.

Application October 11, 1940, Serial No. 360,824

6 Claims. (Cl. 62—115)

This invention relates to improvements in refrigeration apparatus.

The general object of the invention is to provide an improved refrigeration apparatus including a novel refrigerant circuit.

Another object of the invention is to provide an improved refrigeration apparatus including multiple stage compression for the refrigerant.

A further object of the invention is to provide a refrigeration apparatus including fluid means for compressing the refrigerant.

Other objects and the advantages of this invention will be apparent from the following description taken in connection with the accompanying drawings, wherein:

Fig. 1 is a side elevation of an improved refrigeration apparatus;

Fig. 2 is a top plan view of the apparatus shown in Fig. 1;

Fig. 3 is an enlarged fragmentary section through the gear pump taken on line 3—3, Fig. 2;

Fig. 4 is an enlarged fragmentary section through the rotary valve taken on line 4—4, Fig. 2;

Fig. 5 is an enlarged vertical section through the evaporator tanks with portions thereof in elevation;

Fig. 6 is a section taken on line 6—6, Fig. 1; and

Fig. 7 is a fragmentary section through one of the receiver tanks showing a modified form of compression means.

Referring to the drawings by reference characters we have indicated our improved refrigeration apparatus generally at 10. As shown the device 10 includes a pair of tanks 12 and 13, a receiver tank 14, an expansion coil 15, a gear pump 16, a rotary valve 17, a compressor 18 and a drive means which is shown as an electric motor 16.

As shown each of the evaporator tanks 12 and 13 includes a vertically disposed hollow cylindrical housing 20 having cooling fins 21 thereon. The top of the housing is closed by a cap member 22 and the bottom is closed by a cap member 23.

The bottom cap 23 includes a vertically disposed hollow cylinder 24 integral therewith and which is coaxial with the housing 20 spaced therefrom and terminates below the upper cap 22.

The upper end of the cylinder 24 is closed by a dome shaped cap 25 which is threadedly secured thereto as at 26. The cap 25 includes a transverse horizontal partition 27 having an upwardly convergent valve seat aperture 28 therein.

Supported on the upper end of the cylinder 24 and clamped thereto by the cap 25 we provide a plate 29 having a central aperture 30 therein

and having therebelow a cage portion 31 in which a buoyant ball member 32 is positioned.

Communicating with the interior of the cap 25 we provide a conduit 33 which extends upwardly into the interior of the cap 22. The conduit 33 has a check valve 34 therein which permits passage from the cylinder 20 into the cap 25 as indicated by the arrow but prevents passage in the opposite direction.

Surrounding the cylinder 24 and spaced therefrom we provide a coiled conduit member 35 the upper portion of which terminates in a conduit portion 36 which communicates with the interior of the cap 25 and has a check valve 37 therein adjacent the cap.

The check valve 37 permits passage through the conduit from the cap to the coil as indicated by the arrow but prevents passage in the opposite direction.

Directly surrounding the cylinder 24 we provide a coiled conduit member 38. Within and adjacent one side of the housing 20 we provide a vertical conduit 39 which extends out of the housing adjacent the top thereof and communicates with a check valve 40.

The check valve 40 permits passage into the conduit 39 as indicated by the arrow but prevents passage in the opposite direction.

Adjacent the tops thereof below the caps 22 the tanks 12 and 13 are connected by a conduit 41 and adjacent their lower ends above the caps 23 they are similarly connected by a conduit 42.

As shown in Fig. 6 the receiver 14 comprises a hollow horizontally disposed closed tank 43 having a conduit coil 44 therein.

As shown in Fig. 3 the gear pump 16 is of the conventional type including a housing 45 having intercommunicating chambers 46 and 47 therein in which meshing gear members 48 and 49 mounted on shafts 50 and 51 respectively are positioned. The housing 45 further includes an inlet port 52 and opposite therefrom an outlet port 53 both of which communicate with the chambers 46 and 47 as shown.

The rotary valve device 17 may be of any desired type and as shown in Fig. 4 includes a housing 55 having a cylindrical recess 56 therein, an inlet port 57, an outlet port 58 opposite the port 57, and at right angles to the inlet and outlet ports opposed ports 59 and 60. The ports 57 and 58 are shown as vertical and the ports 59 and 60 are shown as horizontal. In the recess 56 a rotatable valve member 61 is positioned which includes an operating shaft 62. On opposite sides of the shaft the valve 61 includes passageways

63 and 64 each of which is adapted to communicate with one of the vertical ports and one of the horizontal ports at the same time as shown.

The compressor 18 includes a drive shaft 65 having a pulley 66 thereon which is driven through the medium of a belt 67 by a pulley 68 on the armature shaft 69 of the electric motor 19.

A pulley 70 on the armature shaft 69 of the motor 19 drives a pulley 71 on the drive shaft 50 of the gear pump 16 through the medium of a belt 72.

The drive shaft 50 of the gear pump 16 has a pulley 73 thereon which through the medium of a belt 74 drives a pulley 75 on the operating shaft 62 of the rotary valve device 17.

One end of a conduit 76 communicates with the outlet port 58 of the valve 17 and the opposite end communicates with the inlet port 52 of the gear pump 16.

The outlet 53 of the gear pump 16 is connected by a conduit 76' to the inlet port 57 of the rotary valve 17.

One end of a conduit 77 communicates with the port 59 of the valve 17 and the opposite end communicates with the interior of the cylinder 24 in the tank 12 through the bottom thereof as shown in Fig. 5. The conduit 77 preferably has a plurality of cooling fins 78 thereon.

One end of a conduit 79 communicates with the port 60 of the valve 17 and the opposite end communicates with the cylinder 24 in the tank 13 through the bottom thereof. The conduit 79 like the conduit 78 has a plurality of cooling fins 80 thereon.

The lower end of the coil 35 in the tank 12 is connected by a conduit 81 to a T fitting 82 and the lower end of the coil 35 in the tank 13 is connected by a conduit 83 to the fitting 82.

The fitting 82 is connected by a conduit 84 to the intake 85 of the compressor 18.

The upper end of the coil 38 of the tank 12 is connected by a conduit 86 to a T fitting 87 and the upper end of the coil 38 in the tank 13 is connected by a conduit 88 to the fitting 87.

The fitting 87 is connected by a conduit 89 to the outlet 90 of the compressor 18.

The lower end of the coil 38 in the tank 12 is connected by a conduit 91 to a T fitting 92 and the lower end of the coil 38 in the tank 13 is connected by a conduit 93 to the fitting 92.

One end of a conduit 94 communicates with the fitting 92 and the opposite end communicates with the interior of the receiver 43 through the top thereof.

One end of a conduit 95 having a control valve 96 therein communicates with the interior of the receiver tank 43 through the bottom thereof and the opposite end communicates with one end of the expansion coil 15.

The other end of the expansion coil 15 communicates with one end of a conduit 98 the opposite end of which communicates with the coil 44 in the receiver 43.

The opposite end of the coil 44 communicates with one end of a conduit 99 the opposite end of which communicates with a fitting 100.

The fitting 100 is connected by a conduit 101 to the check valve 40 of the tank 13 and by a pipe 102 to the check valve 40 of the tank 12.

In operation a predetermined amount of refrigerant fluid such as aqua ammonia is introduced in the refrigeration system until the tanks 12 and 13 are approximately two thirds full as indicated by the broken line 103 in Fig. 5.

The cylinders 24 in the tanks 12 and 13, the

gear pump 16, the valve 17 and the associated piping contains a predetermined amount of fluid, which may or may not be refrigerant fluid.

The amount of fluid in the cylinders 24 and associated parts is such that when the level of the fluid in one of the cylinders is adjacent the top thereof the fluid level in the other cylinder is adjacent the bottom thereof as shown in Fig. 5.

When the motor 19 is started to operate the device the gear pump 16 draws fluid through the conduit 76 from the outlet 58 of the rotary valve 17 and forces it through the conduit 76' into the inlet 57 of the rotary valve 17.

As the valve member 63 rotates it alternately affords communication between the conduit 77 and the inlet 57 and at the same time between the conduit 79 and the outlet 58 and then affords communication between the inlet 57 and the conduit 79 and at the same time between the outlet 58 and the conduit 77.

When the valve member 63 is in the position shown in Fig. 4 fluid is being drawn through the conduit 79 from the cylinder 24 in the tank 13 and forced through the conduit 77 into the cylinder 24 of the tank 12.

When the valve member 63 rotates to afford communication between the inlet 57 and the conduit 79 and between the outlet 58 and the conduit 77 fluid is drawn through the conduit 77 from the cylinder 24 in the tank 12 and forced through the conduit 79 into the cylinder 24 in the tank 13.

Thus as the device operates the fluid in the cylinders 24 alternately rises and lowers thus acting as a piston within the cylinders.

When the fluid in one of the cylinders 24 moves downward ammonia vapor is drawn through the conduit 33 and check valve 34 into the cap 25 and into the cylinder 24 and as the fluid in the cylinder rises the ammonia vapor is forced out of the cylinder and cap through the check valve 37 and conduit 36 into and through the coil 35. From the coil 35 it passes through the conduit 84 into the compressor 18 wherein it is further compressed and forced therefrom through the conduit 89 into the upper end of the coil 38. As it is passed downward through the coil 38 the ammonia vapor condenses and the refrigerant fluid is forced out of the lower end of the coil and through the conduit 94 into the receiver 14.

From the receiver 14 the refrigerant fluid is forced through the conduit 95 into the expansion coil 95 wherein it again vaporizes. From the expansion coil 95 the vapor is forced through the conduit 98 into and through the coil 44 in the receiver 14 and thence through the conduit 99 and through the check valve 40 into the conduit 39 in the tank wherein it is forced downward and expelled therefrom into the aqua ammonia in the tank adjacent the bottom of the tank.

The fluid within the cylinders 24 is retained therein by the action of the ball members 32. Should the fluid rise too high the ball member floats into the aperture 28 and prevents discharge therethrough.

In Fig. 7 we have shown a fragmentary section through one of the cylinders 24 wherein a fluid other than the refrigerant is used. In this instance mercury indicated at 105 is used in the fluid in the cylinder and above the mercury a quantity of oil 106 having a buoyant disc 107 thereon is provided to form a seal to prevent the refrigerant vapors from mixing with the mercury.

It will be appreciated that the vapor pump comprising the cylinders 20 and 24 and the gear pump 16 and the rotary valve device 17 may be

adapted for use in apparatus other than refrigeration equipment.

From the foregoing description it will be apparent that we have provided a novel refrigeration apparatus which is simple in construction and highly efficient in use.

Having thus described our invention we claim:

1. A refrigeration apparatus including a tank, a receiver and an expansion coil, a compression member, a cylinder member within said tank, a refrigerant in said tank and surrounding said cylinder, a liquid in said cylinder, means to reciprocate said liquid, valve means to cause the liquid to act as a piston to draw refrigerant material into said cylinder and force it therefrom to said compressor member, means whereby said compressor member forces refrigerant into and through said receiver to said expansion coil and means to direct said refrigerant from said expansion coil into said tank.

2. A refrigeration apparatus including a pair of tanks, a receiver, an expansion coil and a compressor member, a cylinder member within each of said tanks, a refrigerant in each of said tanks, intercommunicating passageways between said tanks, a coiled conduit in each of said tanks, a liquid in each of said cylinders, means to reciprocate the liquid in said cylinders, valved conduit means to cause liquid in the cylinders to act as oppositely moving pistons to draw refrigerant vapors from said tanks and force it through said coils to said compressor member, means whereby said compressor forces refrigerant into and through said receiver to said expansion coil, and means to direct said refrigerant from said expansion coil back into said tanks.

3. A refrigeration apparatus including a pair of tanks, a receiver, an expansion coil and a compressor member, a coiled conduit in said receiver tank, a cylinder member within each of said tanks, a refrigerant in each of said tanks, intercommunicating passageways between said tanks, a coiled conduit in each of said tanks, a second coiled conduit in each of said tanks, said coiled conduits being partly submerged in the refrigerant in said tanks, a liquid in each of said cylinders, means to reciprocate the liquid from one cylinder to the other to cause a piston action to draw refrigerant vapors from said tanks and force it through said first coils in said tanks to said compressor member, and means whereby said compressor member forces refrigerant through said second coils in said tanks and into and through said tank to said expansion coils, thence through said coil in said receiver and back into said tanks.

4. A refrigeration apparatus including a pair of tanks, a receiver tank, an expansion coil, a compressor member, and a pump member, a coiled conduit in said receiver, a cylinder member in each of said tanks, a refrigerant in each of said tanks, intercommunicating passageways between said tanks, a coiled conduit in each of said tanks, a second coiled conduit in each of said tanks, said coiled conduits being partly submerged in said refrigerant in said tanks, a liquid in each of said cylinders, conduit means connecting each of said cylinders and said pump member, flow control means interposed in said conduit means to alternately direct flow from said pump to one of said cylinders and direct flow from said cylinder to said pump to re-

ciprocate said liquid in said cylinders to thereby cause said liquids to act as oppositely moving pistons to draw refrigerant vapors from said tanks and force it through said first coils in said tank to said compressor member, conduit means permitting said compressor member to force refrigerant through said second coils in said tanks and into and through said receiver to said expansion coils, thence through said coil in said receiver and back into said tanks below the fluid level therein.

5. In a refrigeration apparatus, a closed vertical tank, a hollow cylinder within said tank and spaced therefrom, liquid refrigerant surrounding said cylinder and partially filling said tank, gaseous refrigerant filling the space above said liquid refrigerant, fluid within said cylinder, means to pump fluid alternately from and to the cylinder, valve means on the cylinder to permit passage of gaseous refrigerant from said tank into said cylinder upon withdrawal of said fluid, a coiled conduit surrounding said cylinder, a compressor, one end of said coiled conduit communicating with the intake of said compressor, the other end of said conduit communicating with the interior of said cylinder and adapted to receive gaseous refrigerant therefrom upon the rise of said fluid therein, a second coiled conduit within said tank and surrounding said cylinder one end of said second conduit communicating with the discharge of said compressor, a receiver, the other end of said second conduit communicating with said receiver, a conduit leading from said receiver to the interior of said tanks below the surface of the liquid refrigerant therein, an expansion coil and a conduit from said receiver communicating with the expansion coil.

6. In a refrigeration apparatus, a pair of closed vertical tanks, a hollow cylinder within each of said tanks and spaced therefrom, liquid refrigerant surrounding said cylinders and partially filling said tanks, gaseous refrigerant filling the space above said liquid refrigerant, fluid within said cylinders, a gear pump adapted to pump the fluid alternately from one cylinder to the other, valve means to alternate the direction of flow from one cylinder to the other, valve means at the top of each cylinder adapted to permit passage of gaseous refrigerant from said tank into each cylinder upon withdrawal of fluid therefrom, a coiled conduit surrounding said cylinders, a compressor, one end of said coiled conduit communicating with the intake of said compressor, the other end of said conduit communicating with the interiors of said cylinders and adapted to receive gaseous refrigerant therefrom upon the rise of said fluid therein, a second coiled conduit within said tanks and surrounding said cylinders, one end of said second conduit communicating with the discharge of said compressor, a receiver, the other end of said second conduit communicating with said receiver, a conduit leading from said receiver to the interiors of said tanks below the surface of the liquid refrigerant therein, an expansion coil and a conduit affording communication between said receiver and said expansion coil.

IAN DU BOIS SMITH.
CONRAD ROBERT BUCHET.