

M. M. SCHANEY.
SHOE CALK.
APPLICATION FILED MAR. 27, 1908.

919,082.

Patented Apr. 20, 1909.

Fig. 1.

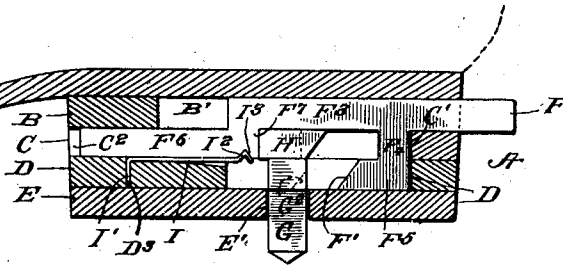

Fig. 2.

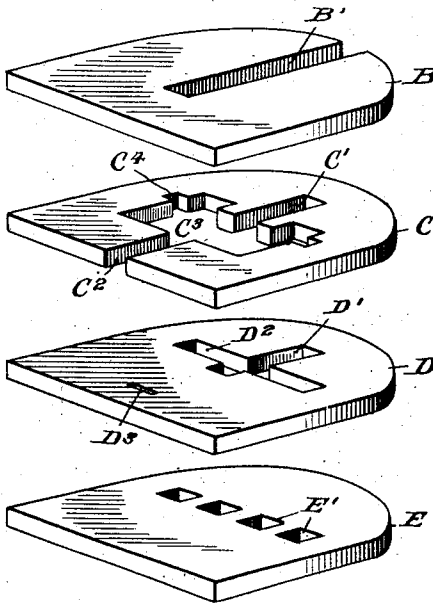

Fig. 5.

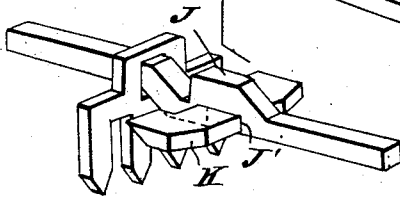

Fig. 3.

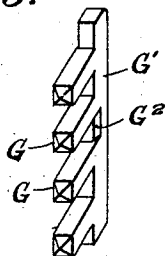
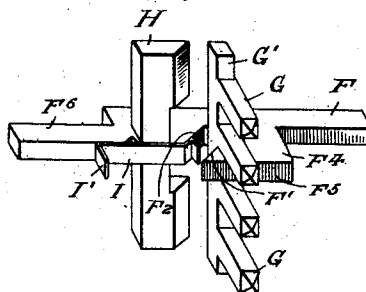

Fig. 4.



WITNESSES

L. H. Schmidt.
J. Middleton

INVENTOR
MICHAEL M. SCHANEY,
BY *Munn & Co.*
ATTORNEYS.

UNITED STATES PATENT OFFICE.

MICHAEL M. SCHANEY, OF DUBOIS, PENNSYLVANIA.

SHOE-CALK.

No. 919,082.

Specification of Letters Patent.

Patented April 20, 1909.

Application filed March 27, 1908. Serial No. 423,499.

To all whom it may concern:

Be it known that I, MICHAEL M. SCHANEY, a citizen of the United States, and a resident of Dubois, in the county of Clearfield and State of Pennsylvania, have invented certain new and useful Improvements in Shoe-Calks, of which the following is a specification.

My invention is an improvement in ice creepers and has for an object to provide a novel construction built mostly inside of the heel of boots or shoes and including spikes or calks arranged to be projected and retracted by means of cams on a sliding operating rod; and the invention consists in certain novel constructions and combinations of parts as will be hereinafter described and claimed.

In the drawings, Figure 1 is a vertical longitudinal section of a heel provided with my improvement. Fig. 2 illustrates in perspective the different lifts of the heel detached and spaced apart to illustrate the construction thereof. Fig. 3 is a detail perspective view of the calk bar. Fig. 4 is a detail perspective view of the calk bar and the means for operating the same, and Fig. 5 shows a somewhat different construction whereby the calks may be projected and retracted by a slide bar operating through an opening in the calk carrier.

In carrying out my invention the heel A has its lifts B, C, D, and E suitably apertured for the operation of the different parts, and the slide F for operating the calks G is provided with cams F', F², operating on opposite sides of the calk carrier G' to advance and retract the calks. The slide F is of such length as to project at one end beyond the heel, its rear end projecting when the calks are extended and its front end projecting when the calks are retracted. As shown, the slide F has its body portion F³ operating in a longitudinal slot B' in the lift B, and is provided near its rear end with a depending arm F⁴, which projects downwardly through a slot C' in the lift C and operates in a slot D' in the lift D, and has at its lower end, within the lift D, a forwardly projecting portion F⁵ whose front end is inclined to form a cam F' which operates to lift the calks when the slide is pushed forward.

At its front end the body portion F³, is provided with a front extension F⁶ in a lower plane than the body portion F³ and operating in a slot C² leading to the front end of the lift C, the rear end of the forwardly projecting portion F⁶ forming a shoulder at F⁷,

against which a cross bar H is abutted. This cross bar H underlies the body portion F³, and operates within an opening C³ in the lift C, and in practice overlies the calk bar G' when the calks are projected, as shown in Fig. 1, and prevents any upward displacement of the said calks. The opening in the lift C has lateral wings C⁴, in which the ends of the calk bar G' project when the calks are retracted, and the said calk bar operates in lateral slot D² in the lift D when the calks are projected as shown in Fig. 1. The lift E is provided with openings E' within which the calk G operates as will be understood from Figs. 1 and 2 of the drawings.

I provide detent means for holding the parts with the calks projected and retracted, and the same consists preferably of a spring I having at one end a downwardly turned wing I' fitting in the slot D³ in the lift D and having at its rear end a bearing portion I² which engages in a notch I³ in the slide F when the parts are in the position shown in Fig. 1, and also engages at F² with the slide rod, see Fig. 4, when the slide rod F is pushed forward to retract the calks. The detent means thus operates to hold the calks in both projected and retracted positions as is desired.

By my invention it will be noticed I provide the heel with disappearing calks operated by a slide provided with inclined planes or cams for operating the calk bar. Manifestly, this broad idea of the invention might be carried out by the construction shown in Fig. 5, in which the calk carrier J has an opening J', and a slide K has inclined portions for advancing and retracting the calk, but I prefer to construct it, as shown and before described, because it effectually serves the purpose for which it is designed.

It will be understood that the bar H is rigid with the slide F and may be made integral with or suitably secured to the said slide as found most convenient in manufacturing the device for any particular use.

In operation when the parts are in the position shown in Fig. 1, the calks are projected for use. If now the slide F be pushed forwardly the cam F' will operate beneath the calk carrier G' and lift the calks to a position in which their lower ends will be flush with or above the under surface of the heel.

I claim—

1. A heel having an upper lift provided with a longitudinal slot leading to its rear

110

edge, a lower lift having openings through which calks may protrude, and intermediate lifts having openings for the reception and operation of a calk carrier and its operating parts, a calk carrier having depending calks to protrude through the openings in the lower lift, an operating slide having a main or body portion operating in the slot of the upper lift, and a depending arm having a cam to operate upon and lift the calk carrier, the slide having in advance of said cam, a cam or incline to engage upon and operate the calk carrier to project the calks, and a cross bar carried by the slide and adapted to overlie the calk carrier when the calks are projected, and detent means consisting of a spring having a portion engaging with the slide in the adjustment of the parts, whereby to secure the parts in the different adjustments, substantially as set forth.

2. The combination with a heel, and a series of calks movable vertically therein, and a bar carrying said calks, of an operating slide having a forwardly facing cam to engage below and lift the calk bar, and also provided with a rearwardly facing cam above and in advance of the forwardly facing cam and adapted to operate upon the upper side of the calk bar, all substantially as and for the purposes set forth.

3. The combination in an ice creeper, of a series of calks, and a bar carrying the same, a slide operating within the heel, and having means for projecting and retracting the calks, and a cross bar or bolt operated by the slide and adapted to overlie the calk bar

when the calks are projected and secure the same in such position, substantially as set forth.

4. The combination with calks and a slide movable in a direction at a right angle to the direction of movement of the calks for projecting and retracting the same, of a detent having a spring engagement with the slide, substantially as set forth.

5. The combination with a heel, of calks, a calk bar, a slide having cams for advancing and retracting the calks, and a spring engaging with the slide in both positions of the parts, whereby to hold the calks advanced or retracted, substantially as set forth.

6. The combination of calks and a bar carrying the same, a slide for operating the calks, and having a cross bar or bolt and also provided with a depending portion having a forwardly facing cam, and in advance of and above said forwardly facing cam with a rearwardly facing cam, said cams being adapted to engage with the calk bar and operate the calks in reverse directions, and a heel having the top lift slotted for the rear end of the slide, and intermediate lifts slotted for the forwardly facing cam, and the lower lift perforated for the passage of the calks, and one of the intermediate lifts having openings for the operation of the cross bar on the slide, all substantially as and for the purposes set forth.

MICHAEL M. SCHANEY

Witnesses:

WARREN T. SHAFFER,
GEO. W. CUSTER.