

*J. P. Herron,
Baggage Seal.*

No. 107,370

Patented, Sept. 13, 1870.

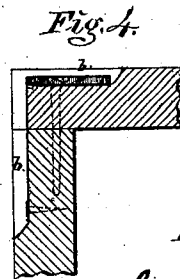
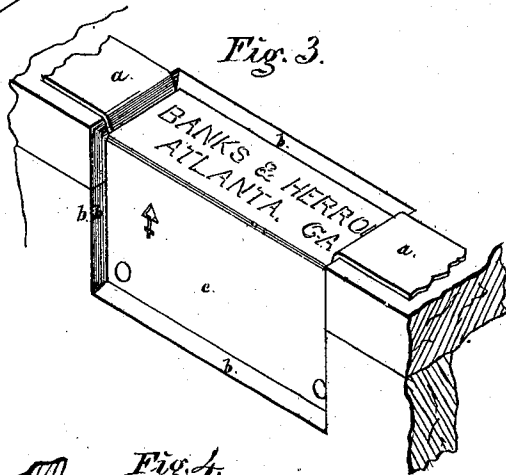
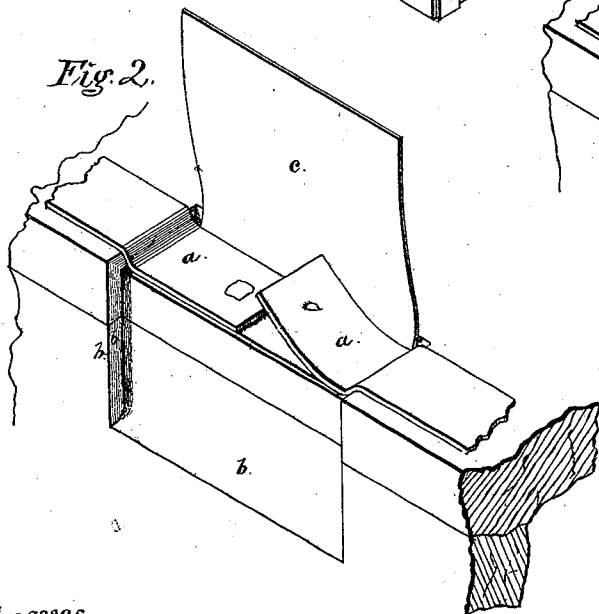
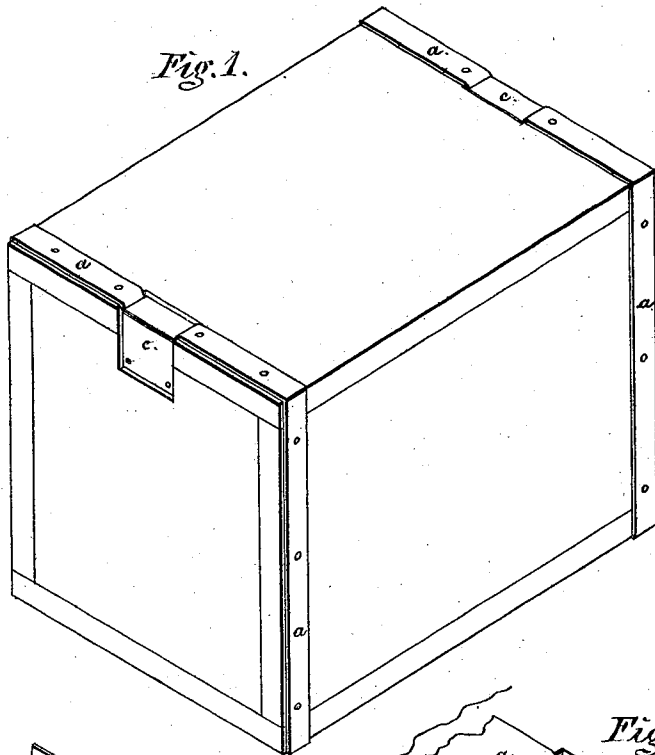

*Witnesses,
Guy C. Humphreys
J. H. Herron,*

*Inventor,
James P. Herron*

United States Patent Office.

JAMES P. HERRON, OF ATLANTA, GEORGIA.

Letters Patent No. 107,370, dated September 13, 1870.

IMPROVEMENT IN SEALS FOR METAL STRAPS ON BOXES.

The Schedule referred to in these Letters Patent and making part of the same

To all whom it may concern:

Be it known that I, JAMES P. HERRON, of Atlanta, in the county of Fulton, in the State of Georgia, have invented a new and useful Method of Sealing Freight-Packages, for the purpose of insuring detection in the right quarter when such packages are surreptitiously opened and their contents feloniously abstracted while *in transitu*; and I do hereby declare the following to be a full, clear, and exact description thereof, reference being had to the annexed drawing making part of this specification, in which—

Figure 1 represents a freight-package with my detective-seal attached;

Figures 2 and 3 are enlarged views of the seal and its application; and

Figure 4 is a transverse section of the same.

This seal is intended for and can only be used upon packages that are bound or strapped with iron or other bands, such as cases of dry-goods, shoes, &c.; but, with the adjunctive measures to be adopted at its introduction into use, it will be found to be of great practical utility, not only to the purchaser of a package of goods, but also to the seller, for whom it may be an advertising medium. It is a simple device, involving but trifling expense and trouble, which will be more than compensated for by the security it will give, and will be the means of considerable saving to transportation companies and others, who not unfrequently have to pay large sums for goods lost while supposed to be in their custody. No drayman, porter, or other carrier, can open a box without furnishing evidence that it has been opened in the mutilation of the seal, which it is impossible to hide after having been effected, and a detection of the culprit is sure to follow, by means to be hereafter described.

In the drawing, fig. 1, is a view of a box-package bound in the ordinary manner, by straps of metal *a* around the ends of its sides.

Where the ends of the bands meet the wood is cut away on the end and side, at the corner of the box, to make a depression, *b*, by a tool constructed for the purpose, to a depth sufficient to allow the band to sink into it, so as to be below the surface and out of the way of injury as the box is "cut round" or "man-handled."

Under the ends of the strap *a* is laid the edge of

the seal *c*, which is a plate of tough and flexible metal, of any kind that may be best adapted to the purpose, as is shown in figs. 2 and 4. The ends of the band *a* are then secured by nailing down through both band and seal into the wood. The plate *c* is then folded over the ends of the band, so as to cover them, and is bent down, as shown in figs. 3 and 4, so as to be within the depression *b* on the end of the box, where it is secured by tacking.

It is manifest that no means can be taken to open the box without giving evidence of the fact that the attempt has been made; for if the band *a* has been cut it cannot be mended, and the seal cannot possibly be removed without defacing it in such a manner as to make it a convicting, if silent, witness.

The seal *c* may be stamped with the name and business address of the party who makes up and ships the package. Those who receive the box for transportation or use of contents notice that the seal is not defaced when it reaches them, and before they consent to receive it. If the seal is sound they stamp upon it their initials, a trade-mark, or some device which they may adopt for the purpose, and which will be evidence that the box came to them in good condition. If, when a box be delivered to any party, the seal is discovered to be mutilated or defaced, the porter, drayman, or other carrier who fetched it is to be held personally accountable for the marring of the seal between where he received it and the place where it was refused. The injury to the seal will be held to be *prima facie* evidence of a criminal attempt, if not a consummation, on the part of the individual who had the package last in charge.

Having thus fully described my invention,

What I claim therein as new, and desire to secure by Letters Patent, is—

1. The seal *c*, in combination with the bands *a*, substantially as and for the purpose set forth.
2. In combination with the foregoing, the depression *b* in the material of the box, made for the purpose of protecting the seal from injury when handled, as set forth.

JAMES P. HERRON.

Witnesses:

GUY P. HUMPHRIES,
I. H. HERRON.