

June 1, 1937.

L. W. CHILD

2,082,441

AIR CONDITIONER

Filed June 8, 1934

4 Sheets-Sheet 1

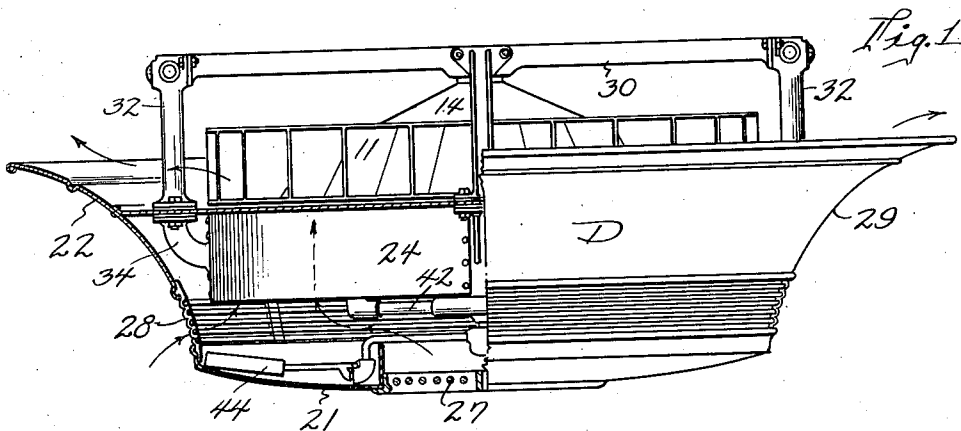

Fig. 1

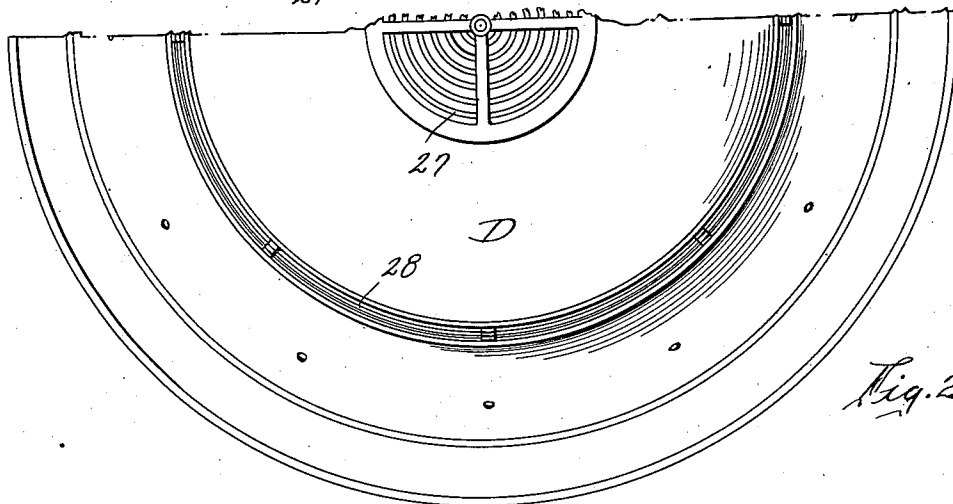

Fig. 2

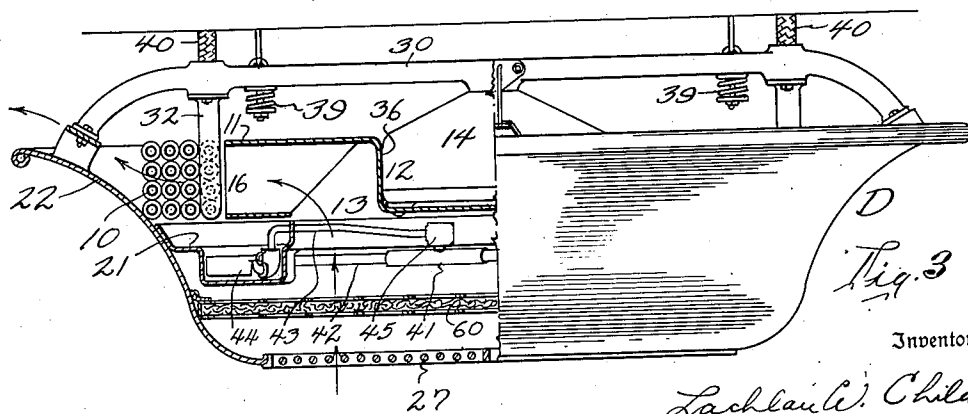

Fig. 3

Inventor

Lachlan W. Child

Lynn A. Latta Attorney

June 1, 1937.

L. W. CHILD
AIR CONDITIONER
Filed June 8, 1934

2,082,441

4 Sheets-Sheet 2

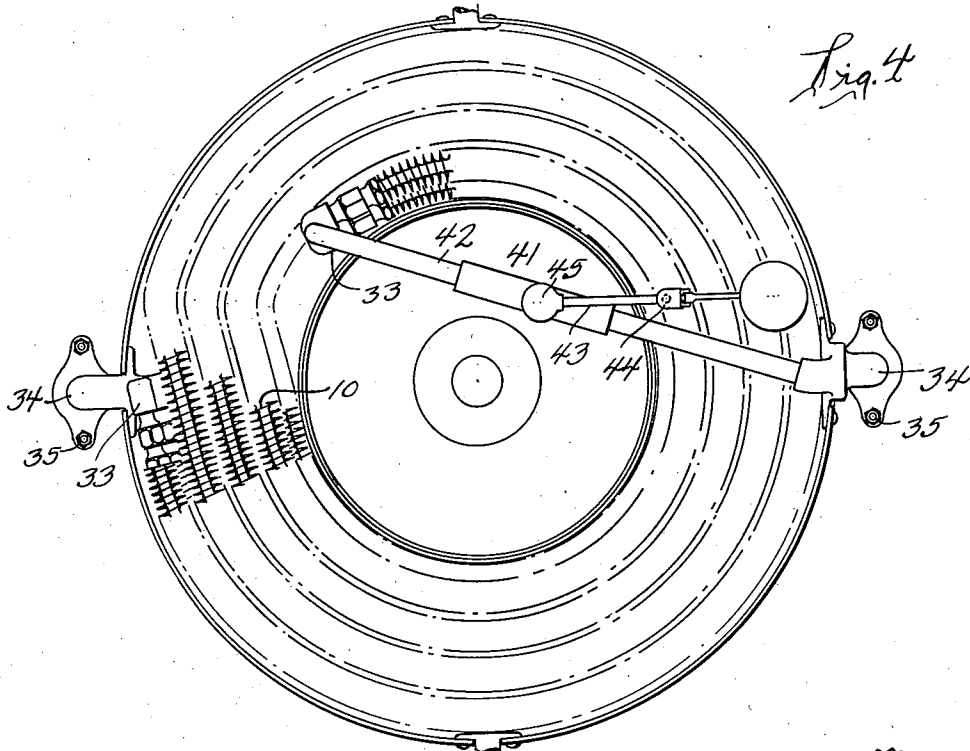

Fig. 4

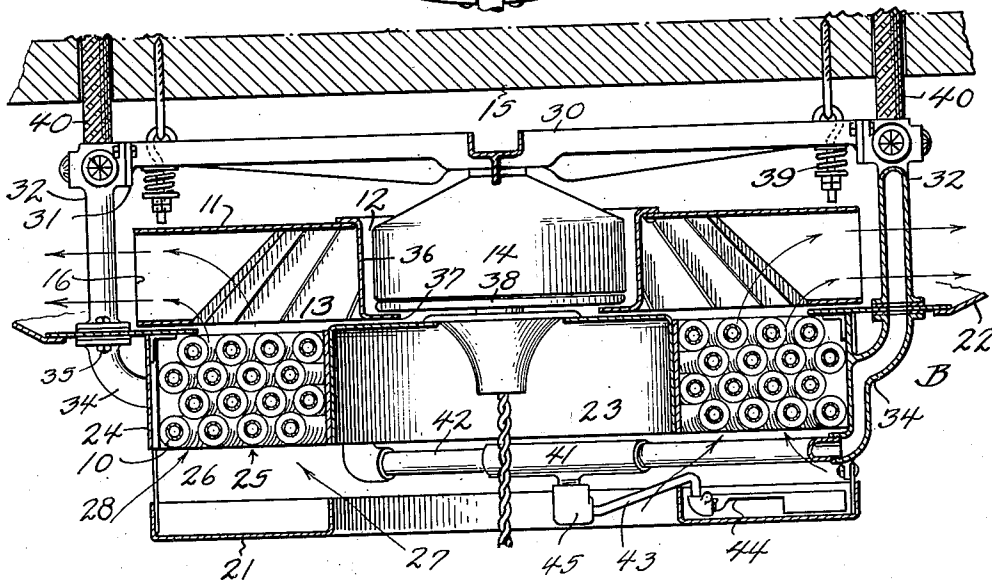

Fig. 5

Inventor
Lachlan W. Child

Lynn Watta Attorney

June 1, 1937.

L. W. CHILD
AIR CONDITIONER
Filed June 8, 1934

2,082,441

4 Sheets-Sheet 3

Fig. 0

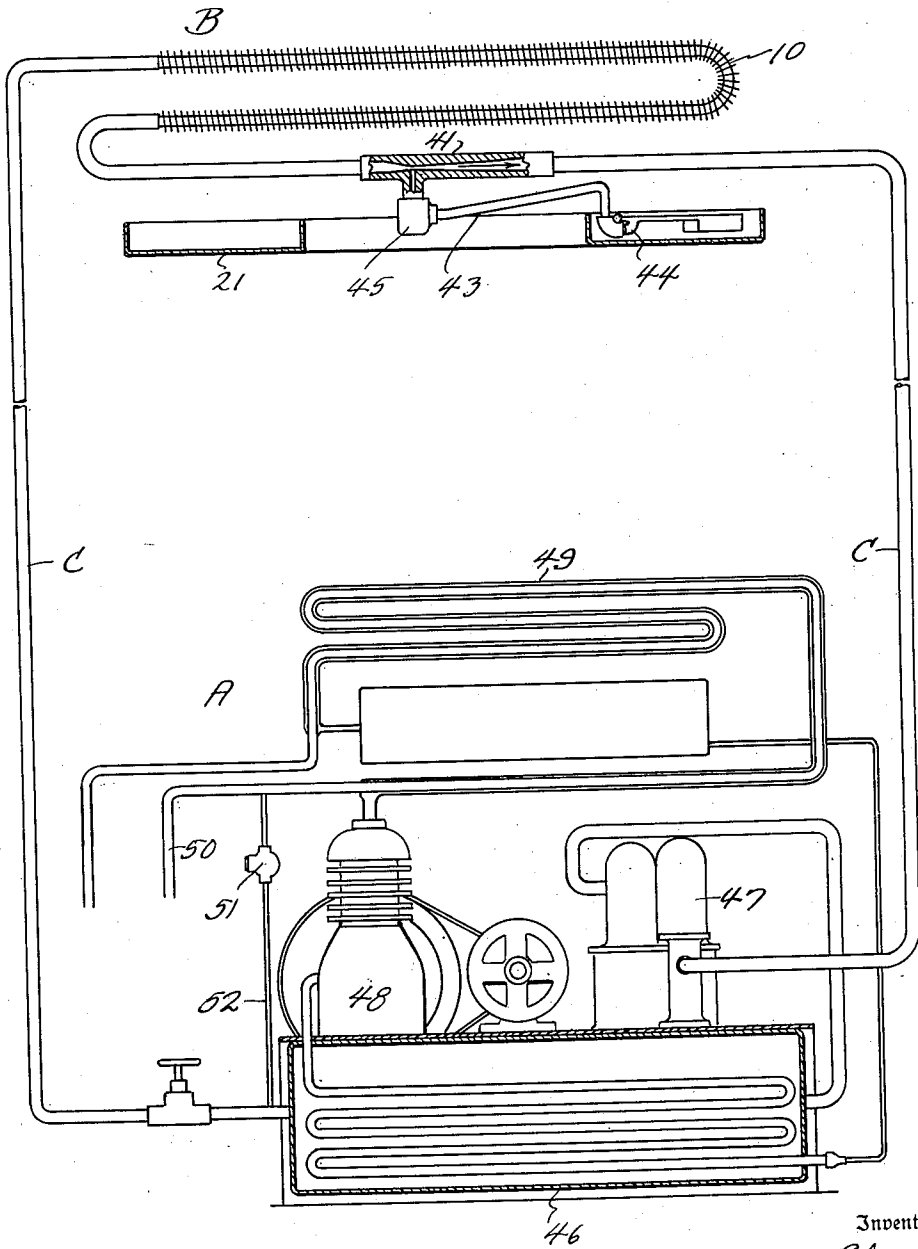

Inventor

Lachlan W. Child

By

Lynn H. Latta

Attorney

UNITED STATES PATENT OFFICE

2,082,441

AIR CONDITIONER

Lachlan W. Child, Toledo, Ohio, assignor, by
mesne assignments, to Air Devices Corpora-
tion, Chicago, Ill., a corporation of Delaware

Application June 8, 1934, Serial No. 729,544

26 Claims. (Cl. 62-134)

This invention relates to air cooling and de-
humidifying, and has as its object to improve
upon the type of air conditioner in which the
conditioning mechanism is located in the room to
be conditioned, utilizing a refrigerating liquid
which is piped from a remotely located refriger-
ator.

A primary object is to achieve maximum effi-
ciency in the distribution of cooled air into a
room. To this end, the invention contemplates
the radial distribution of cooled air from a condi-
tioner suspended in the upper region and centrally
of the space to be conditioned, in all direc-
tions in a horizontal plane. The greater heaviness
of the cooled air as compared to the warmer
unconditioned air, will aid it in moving down-
wardly near the side walls of the enclosure, and
the direction of flow will thence be toward the
center in the lower region of the room, and thence
upwardly to the conditioner. As a result, the air
in the lower region of the room, which contacts
the occupants thereof, will have been tempered
by mixing of the cooled air issuing from the con-
ditioner with warmer air, so that the occupants
are subjected only to the equalized or average air
in the room, and are not exposed to any draft of
cold air.

In line with this aim, it is my object to pro-
vide a conditioning unit of what may properly be
called the "suspended" type, adapted to best pro-
duce the circulation of air in the manner stated
above.

Another object is to provide such a conditioning
unit, arranged to avoid the short circuiting of
air currents from discharge mouth to inlet mouth.

A conditioner thus positioned may be properly
called a "suspended" type unit. A further object
of the invention is to provide in a unit of this
type means for completely and automatically dis-
posing of water of condensation and insuring
against the dripping of any moisture from the
unit.

The invention further contemplates the pro-
vision of an air cooling unit having maximum
cooling capacity in proportion to its bulk.

In this connection, the invention contemplates
securing maximum efficiency from a ring shaped
or "doughnut" heat transfer unit. It is found
that a type of fan which is admirably suited to
the hereinbefore mentioned radial distribution of
the cooled air, lends itself perfectly to the suc-
cessful utilization of the "doughnut" element.

Another object of the invention is to provide
a conditioning unit which lends itself readily to

artistic and ornamental execution in the lines
of its visible exterior.

A further object is to provide a conditioning
unit which is practically silent in operation.

With these and other objects in view my in-
vention consists in the combination and con-
struction and arrangement of the various parts
thereof, whereby the objects contemplated are
attained, as more fully set forth in the accom-
panying specifications, pointed out in my claims,
and illustrated in the accompanying drawings, in
which:

Fig. 1 is an elevation partly in section, of a con-
ditioning unit embodying the invention.

Fig. 2 is an inverted plan view of the same.

Fig. 3 is a view similar to Fig. 1 of a modified
form of unit embodying the invention.

Fig. 4 is an inverted plan view of the con-
ditioning unit of Fig. 3.

Fig. 5 is a vertical central sectional view of
the same.

Fig. 6 is a diagram of the condensate ejector
mechanism.

Fig. 7 is a plan of another modification.

A complete system embodying the invention
will include a refrigerating unit A (Fig. 6), a con-
ditioning unit B, and a fluid line C—C connect-
ing the two units. A detachable casing D forms
the visible part of or cover for the conditioning
unit, B.

The present invention embodies what is com-
monly called a "closed" system, the cooling of the
air being accomplished by a fluid circulating ele-
ment 10, forming a closed circuit with the fluid
line C and refrigerator A. The fluid preferably
is water, cooled in the refrigerator A.

The element 10 is in the shape of a ring or an-
nulus. It is preferably constructed of a number
of nested spiral pancake coils of what is known
commercially as "fintubing".

The air distribution means comprises a cen-
trifugal fan 11 the central region 12 of which is
"dead", i. e., does not handle air, and the inlet
13 of which is annular, encompassing said "dead"
central region. The central region 12 accom-
modates the motor 14 which drives the fan,
whereby the fan may be positioned quite close
to the ceiling 15 from which the unit is sus-
pended.

The fan 11 is entirely unshrouded, the space
around the discharge mouth 16 being entirely
open. In the form shown in Fig. 1, the heat
transfer element 10 is positioned just below the
annular inlet mouth 13, registering therewith so
that all air entering the conditioner must pass

through the element in its passage to the mouth 13.

In the form shown in Fig. 3, the cooling element 10 is arranged closely encompassing the discharge mouth 16 and registering therewith so that all air leaving the fan will pass through the element in a radial direction. In each case the air enters the conditioning unit in a generally upward axial direction and leaves it in a horizontal plane, spreading out radially in all directions. As a result, the air movement in a room equipped with the conditioner will be generally upward at the center of the room to the conditioner, the cold conditioned air being discharged horizontally, thence moving downwardly adjacent the vertical walls of the room and absorbing, during such movement, the currents of heated air which may seep into the room from the outside, thence converging horizontally inwardly in the lower region of the room, sweeping away the foul and heated air in the vicinity of the occupants, and thence moving upwardly in the center of the room. Downward movement 18 is assisted by the heaviness of the cooler air, and upward movement is assisted by the buoyancy of the air currents after absorbing heat, and the suction induced by the inspiration into the inlet mouth of the conditioner.

In order to prevent any moisture condensed on the element 10 from dripping into the room, I provide a drip pan 21, suspended below the cooling element 10. In the form shown in Fig. 3, the pan is attached to and forms a part of the conditioner operating mechanism B, and in the form shown in Fig. 1, the pan forms the bottom of the outer casing.

The drip pan is preferably annular, so that at least part of the air entering the conditioner will enter vertically at the center of the bottom, thus minimizing the possible short circuiting of discharged cold air directly back into the conditioner.

A deflector collar 22 deflects the discharge upwardly so as to counteract what would otherwise be a downward inclination of the discharged air. Such downward inclination has been noted where the deflector collar is absent. This further avoids short circuiting.

The fan 11 is, in the form shown in Fig. 1, substantially the full diameter of the conditioning unit. It revolves at the relatively slow speed of about two hundred fifty revolutions per minute. The motor 14 is a slow speed motor. The fan secures volume through its large size. It is virtually noiseless in operation for two reasons: first, because of its slow rate of revolution; second, because it is not shrouded, but delivers its air stream directly into the surrounding atmosphere.

In order to confine the air passing through the heat transfer element so as to force it all to contact the element, I provide, in the forms shown in Fig. 1, casing 23 and an outer casing 24 between them forming an annular cooling space 25 communicating with the mouth 13.

Air reaches the annular cooling space 25 by passing through the center and around the outside of the drip pan 21 into the space 26 between the top of the pan 21 and the bottom of the element 10, as indicated by the arrows, whence it passes upwardly into the space 25.

The outer casing D is provided with inlet grilles 27 and 28. In the form shown in Fig. 1, the grille 28 connects the pan 21 to the hood 29 of the casing, and the grille 27 is mounted in the central opening of the pan 21.

In the form shown in Fig. 3, there is only the one inlet grille 27, which is made larger to handle the full volume of air passing through the conditioner.

It will be noted that the conditioner is roughly in the shape of a bell, with inlet openings in the small end below, and with the discharge opening between the large end of the bell and the ceiling, whereby the rising column of air is drawn upwardly and thence guided into a horizontally spreading blanket, the conditioner and ceiling forming, as it were, a plurality of elbow connections to guide the incoming air currents around the right angled bends in the air current paths.

The conditioner embodies a frame structure including a spider 30 the arms of which are provided at their ends with flanges 31 to which are bolted the upper ends of depending posts 32. At least two of the posts 32 are hollow, and connected to the element 10 and inlet and exhaust connections respectively. Preferably the connection to the element 10 is through manifolds 33 each having an elbow 34 which is detachably secured by bolts 35 to the lower end of its corresponding post 32. (Figs. 1 and 5). In such case, the element casing 24 is carried by the elbows 34, and by removing the bolts 35, the entire element 10 and its confining casings 23 and 24, as well as the pan 21 and deflecting collar 22, may be dropped.

The motor 14 is secured to the central region of the spider 30, and the fan 11 is carried by the motor. Thus the fan and motor may remain suspended while the element 10 is removed for inspection or repair. The central drum 36 of the fan is secured at 37 to the rotor 38 of the motor.

The spider 30 is suspended from the ceiling 15 on resilient suspensions 39. The posts 32 are connected to the fluid line C by flexible connecting tubes 40. This prevents transmission of vibration to the ceiling, thus insuring silent operation.

The water collected in the pan 21 is drawn off by a Venturi ejector pump 41, which is connected in the cold water line at the conditioner so as to draw the condensate into the cold water line at the conditioner, completely obviating the use of any auxiliary pipe from the pan 41 back to the region of disposal into a sewer or drain. This is very important for the reason that in many buildings, the drain pipes are so located that the addition of a drain pipe from each conditioning unit to the sewer system of the building, would involve much added expense, difficulty, and complication.

The pump 41 is preferably located in a tube 42 connecting one of the elbows 34 to its manifold 33. This tube also serves to arrange the second manifold 33 in the near vicinity of the first manifold 33, while the elbows 34 are positioned 180° apart. The close positioning of the manifolds, as shown in Fig. 4, gives a somewhat greater compactness of the element.

A tube 43 connects the pump 41 to the pan 21. The end of the tube which extends into the pan is provided with a float valve 44. When the level of the condensate is low, the valve closes to prevent air being sucked into the system. When the level raises, the valve opens and the excess is drawn off.

A check valve 45 prevents water from running out of the system into the pan 21 when the system is not operating. Suction set up in the pump 41 opens the check valve.

The excess water which is added to the system by the drawing off of the condensate, is ejected at the refrigerator A, which comprises a tank 46, a pump 47 to pump the return water from the conditioner into the tank 46 under pressure, the refrigerant compressor 48 which compresses the refrigerant into the condenser coil 49 where it is cooled by the circulation of water in the cooling coil 50, the discharge side of which empties to the sewer. The excess water builds up the pressure in the tank 46, and a relief valve 51 allows the excess to escape through the elimination tube 52 into the cooling coil 50 or into any drain tube leading to the sewer.

Thus the excess water is eliminated at the refrigerator, which must be connected to the sewer anyway, and which is usually located in the basement, and two pipes are needed to connect the refrigerator to the conditioning unit.

The conditioning unit will operate efficiently whether hung directly adjacent the ceiling, or, in a high room, at a distance below the ceiling. In all cases, it will be suspended above the space to be conditioned, i. e., the lower region of the room, to the height of a normal person.

The conditioner may embody air filtering means. In such case, the filter 60 is mounted just above the intake grille, occupying substantially the full horizontal area of the casing. It is of larger area than the grille, the resistance per square inch of the latter being much less than that of the filter.

The cooling coil in that form of the conditioner which incorporates a filter, is arranged surrounding the mouth of the fan, so as to provide room for the filter without increasing the depth of the unit.

The cooling element need not necessarily be circular. It may embody a polygonal cooling coil 61 as shown in Fig. 7, a cross section of which will be substantially the same as Fig. 3. The drip pan 62 is also polygonal as may also be the casing 63. The coil 61 is preferably built up of straight sections joined at their ends by the posts 32 which in this case may serve as headers.

The word "annular" as used in the claims is intended to include not only the circular shape, but the polygonal shape as well.

I claim as my invention:

1. In an air conditioner, a centrifugal fan having an annular inlet and a dead center, an annular heat transfer element registering with said inlet, and inner and outer annular casings embracing said element between them and forming an annular passage communicating with said inlet.

2. In an air cooler a centrifugal fan mounted on a vertical axis above the space to be conditioned, an annular cooling coil through which the air handled by said fan passes, and an annular drip pan below said coil, said pan having an open center through which air may enter said fan.

3. In an air cooler a centrifugal fan, mounted on a vertical axis above the space to be conditioned, an annular cooling coil through which the air handled by said fan passes, and an annular drip pan below said coil, said pan having an open center through which air may enter said fan, said drip pan forming the bottom of an open top, generally bowl shaped casing surrounding said fan and cooling coil and concealing them from below.

4. An air conditioning unit of the ceiling suspended type including a heat transfer element and a fan positioned coaxially on a vertical axis

above the space to be conditioned, and an annular, generally bowl shaped open top casing surrounding said fan and element, said casing having an inlet opening near its bottom and affording outlet for discharged air above its rim, and said fan arranged to move air upwardly through said casing and to discharge it horizontally radially in all directions, the rim region of said casing comprising a trunco-conical flaring annular deflector for preventing said discharge from assuming a downward angle upon leaving the conditioner and a drip pan below said heat transfer element, for collecting condensate therefrom.

5. An air conditioning unit of the ceiling suspended type including a heat transfer element and a fan positioned coaxially on a vertical axis above the space to be conditioned, and an annular, generally bowl shaped open top casing surrounding said fan and element, said casing having an inlet opening near its bottom and affording outlet for discharged air above its rim, and said fan arranged to move air upwardly through said casing and to discharge it horizontally radially in all directions, the rim region of said casing comprising a trunco-conical flaring annular deflector for preventing said discharge from assuming a downward angle upon leaving the conditioner and a drip pan below said cooling element, for collecting condensate therefrom, which air may pass to said cooling element.

6. In an air cooler a centrifugal fan, mounted on a vertical axis above the space to be conditioned, an annular cooling coil through which the air handled by said fan passes, and an annular drip pan below said coil, said pan having an open center through which air may enter said fan, said drip pan forming the bottom of an open top, generally bowl shaped casing surrounding said fan and cooling coil and concealing them from below, and an annular trunco-conical deflector surrounding the discharge mouth of said fan and opening upwardly to deflect the discharged air into a horizontal plane.

7. An air conditioning unit of the ceiling suspended type comprising a frame adapted to be suspended from the ceiling, a fan mounted in said frame on a vertical axis, a heat transfer element carried by said frame, and an open top generally bowl shaped casing detachably hung from said frame and concealing the fan, said element, and the frame from below, said casing having an inlet opening near its bottom and providing an outlet for discharged air above its rim.

8. An air conditioning unit of the ceiling suspended type comprising a frame adapted to be suspended from the ceiling, a fan mounted in said frame on a vertical axis, a heat transfer element carried by said frame, said frame including fluid transmission ducts connected to said heat transfer element, and an open top generally bowl shaped casing detachably hung from said frame and concealing the fan, said element, and the frame from below.

9. An air conditioning unit of the ceiling suspended type including a heat transfer element and a fan positioned coaxially on a vertical axis above the space to be conditioned, a generally bowl shaped open top casing surrounding said fan and element and concealing the same from below, said casing affording outlet for discharged air above its rim, and said fan arranged to move air in said casing through said heat transfer element and to discharge it horizontally radially in

all directions above said rim of the casing, the rim region of the casing comprising a trunco-conical flaring annular deflector for preventing said discharge from assuming a downward angle upon leaving the conditioner, and a drip pan below said heat transfer unit, for collecting condensate therefrom.

10. An air conditioning unit of the ceiling suspended type including a heat transfer unit; a fan and a generally open top bowl shaped casing surrounding said fan and concealing the same from below, together coaxially positioned on a vertical axis above the space to be conditioned, said casing affording outlet for discharged air above its rim, and said fan arranged to move air in casing through said heat transfer element and to discharge it horizontally in all directions above said rim, the rim region of the casing comprising a trunco-conical flaring annular deflector for preventing said discharge from assuming a downward deflection upon leaving the conditioner.

11. An air conditioning unit of the ceiling suspended type including a heat transfer element and a fan positioned coaxially on a vertical axis above the space to be conditioned, and a generally bowl shaped open top casing surrounding said fan and element and concealing the same from below, said casing affording outlet for discharged air above its rim, and said fan arranged to move air in said casing through said heat transfer element and to discharge it horizontally radially in all directions above said rim of the casing.

12. An air conditioning unit of the ceiling suspended type including a heat transfer element and a fan positioned coaxially on a vertical axis above the space to be conditioned, a generally bowl shaped open top casing surrounding said fan and element and concealing the same from below, said casing affording outlet for discharged air above its rim, and said fan arranged to move air in said casing through said heat transfer element and to discharge it horizontally radially in all directions above said rim of the casing, and a drip pan below said heat transfer unit, for collecting condensate therefrom.

13. In an air cooler, a fan having an annular air handling region, a cooling coil registering with said annular air handling region, and a generally bowl shaped casing, detachably hung below said coil, concealing the same from below, and providing an annular discharge outlet above its periphery.

14. In an air cooler, a fan, mounted on a vertical axis above the space to be conditioned, said fan having an annular air handling region, an annular cooling coil through which the air handled by said fan passes, and an annular drip pan below said coil, said pan having an open center through which air handled by said fan may pass.

15. In an air conditioner, a centrifugal fan having an annular inlet and a dead center, and an annular heat transfer element registering with said inlet, said fan drawing air through said element and discharging it radially in a plurality of directions.

16. An air cooler suspended above a space to be cooled and comprising cooling means and means for circulating air thereover, and supports for suspending said cooler from above and which are formed and connected to supply cooling fluid to said cooling means and to receive the discharge therefrom after use.

17. An air cooler suspended above a space to be cooled and comprising cooling means and

means for circulating air thereover, and supports for suspending said cooler from above and which are formed and connected to supply cooling fluid to said cooling means and to receive the discharge therefrom after use, said cooling means and air-circulating means being removable from below as a unit from said supports.

18. An air cooler suspended above a space to be cooled and comprising cooling means and means for circulating air thereover, and supports for suspending said cooler from above and which are formed and connected to supply cooling fluid to said cooling means and to receive the discharge therefrom after use, and means for removing through one of said supports water condensed from the air being cooled by the cooling means.

19. An air cooling unit comprising an annular cooling coil, means for forcing air thereover, an annular trough below said coil, and a pump within said unit for discharging the condensate collected in said trough.

20. An air cooling unit comprising an annular cooling coil, means for forcing air thereover, an annular trough below said coil, a pump within said unit for discharging the condensate collected in said trough, and an automatic valve for shutting off the intake of said pump when the condensate in said trough is down to a predetermined level.

21. An air cooling unit comprising a cooling device, means for circulating air thereover, connections for circulating fluid to and from said device, means for collecting water condensed from the air cooled by said device, and means for forcing the condensed water into the connection circulating the fluid from said device.

22. An air cooling unit comprising a cooling device, means for circulating air thereover, means for suspending the unit from the ceiling of a room, connections extending through said ceiling for circulating fluid to and from said device, means for collecting water condensed from the air cooled by said device, and means within said unit for forcing the condensed water into the connection circulating the fluid upwardly through the ceiling from said device.

23. An air cooling unit comprising a cooling device, means for circulating air thereover, means for suspending the unit from the ceiling of a room, connections extending through said ceiling for circulating fluid to and from said device, means for collecting water condensed from the air cooled by said device, and means within said unit for forcing the condensed water into the connection circulating the fluid upwardly through the ceiling from said device, said cooling device and said air-circulating means and said water-collecting means and said forcing means being removable as a sub-unit from said suspending means.

24. An air cooling unit comprising a cooling device, means for circulating air thereover, means for suspending the unit from the ceiling of a room, connections extending through said ceiling for circulating fluid to and from said device, means for collecting water condensed from the air cooled by said device, and means within said unit for forcing the condensed water into the connection circulating the fluid upwardly through the ceiling from said device, portions of said fluid-circulating connections being formed as passages in said suspending means, and said cooling device and said air-circulating means and said water-collecting means and said forcing

means being removable as a sub-unit from said suspending means, thereby automatically disconnecting said connections.

5 25. In an air cooler, a fan and an annular cooling element and an annular trough below said element, all coaxially arranged about a vertical axis, and means within said air cooler for forcibly removing condensate collected in said trough.

10 26. A cooling device for a room having means for suspending it from the ceiling and compris-

ing an annular cooling element having an annular condensate collecting trough suspended below it, said trough having an open center through which air may pass, a fan mounted on a vertical axis and having an annular air handling region for circulating room air over said element through the open space at the center of said element and trough, and means for forcibly elevating the condensate in said trough through the ceiling and discharging it outside the room. 10

LACHLAN W. CHILD.