

No. 645,801.

Patented Mar. 20, 1900.

H. J. S. GILBERT-STRINGER & F. WICKS.
APPARATUS FOR JUSTIFYING SET TYPE.

(No Model.)

(Application filed Oct. 12, 1899.)

3 Sheets—Sheet 1.

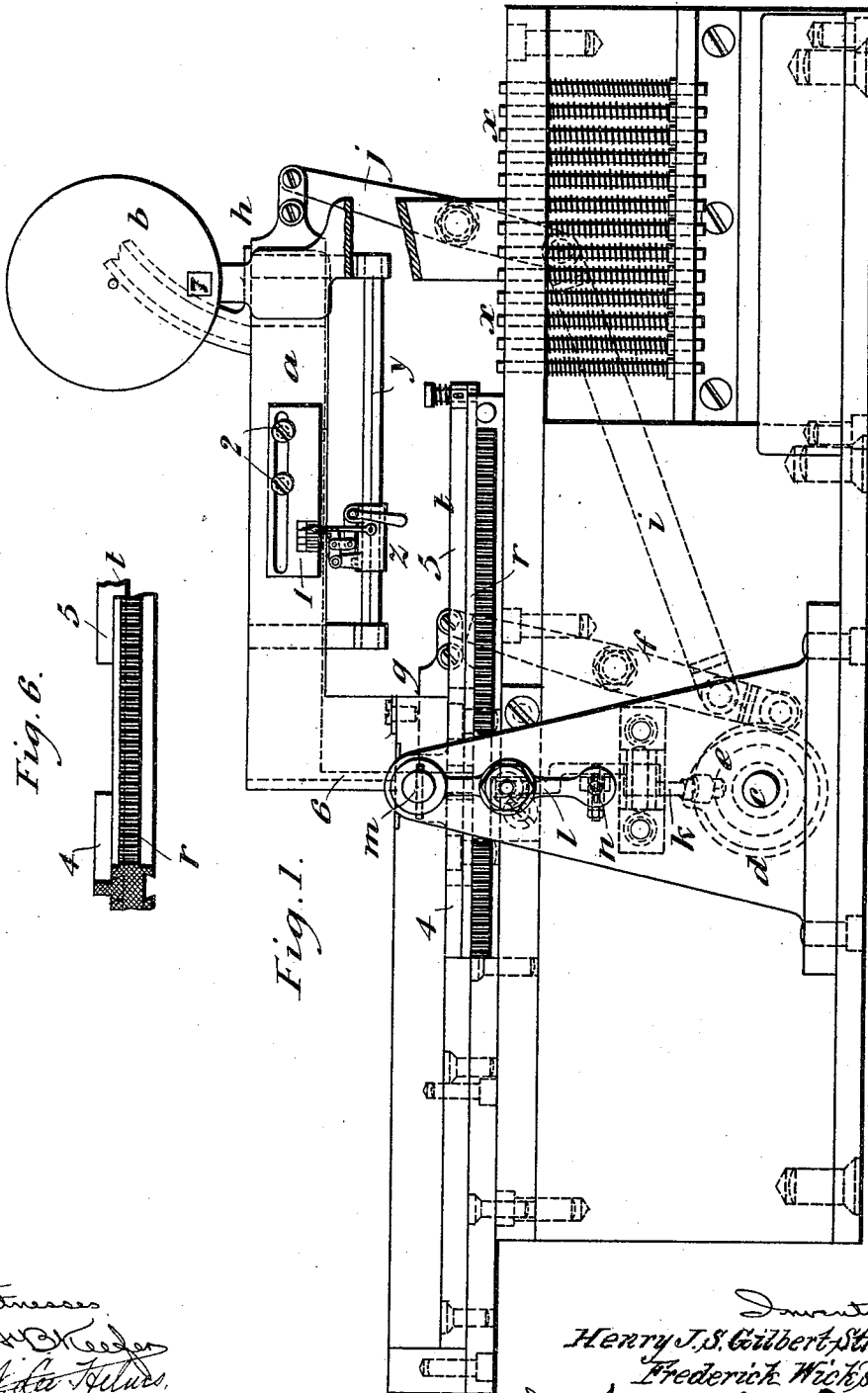

Fig. 6.

Fig. 1.

Witnesses
W. B. Keeler
H. A. Fuller

Inventors
Henry J. S. Gilbert-Stringer,
Frederick Wicks,
James L. Norris,
att'y

No. 645,801.

Patented Mar. 20, 1900.

H. J. S. GILBERT-STRINGER & F. WICKS.
APPARATUS FOR JUSTIFYING SET TYPE.

(Application filed Oct. 12, 1899.)

(No Model.)

3 Sheets—Sheet 2.

Fig. 2.

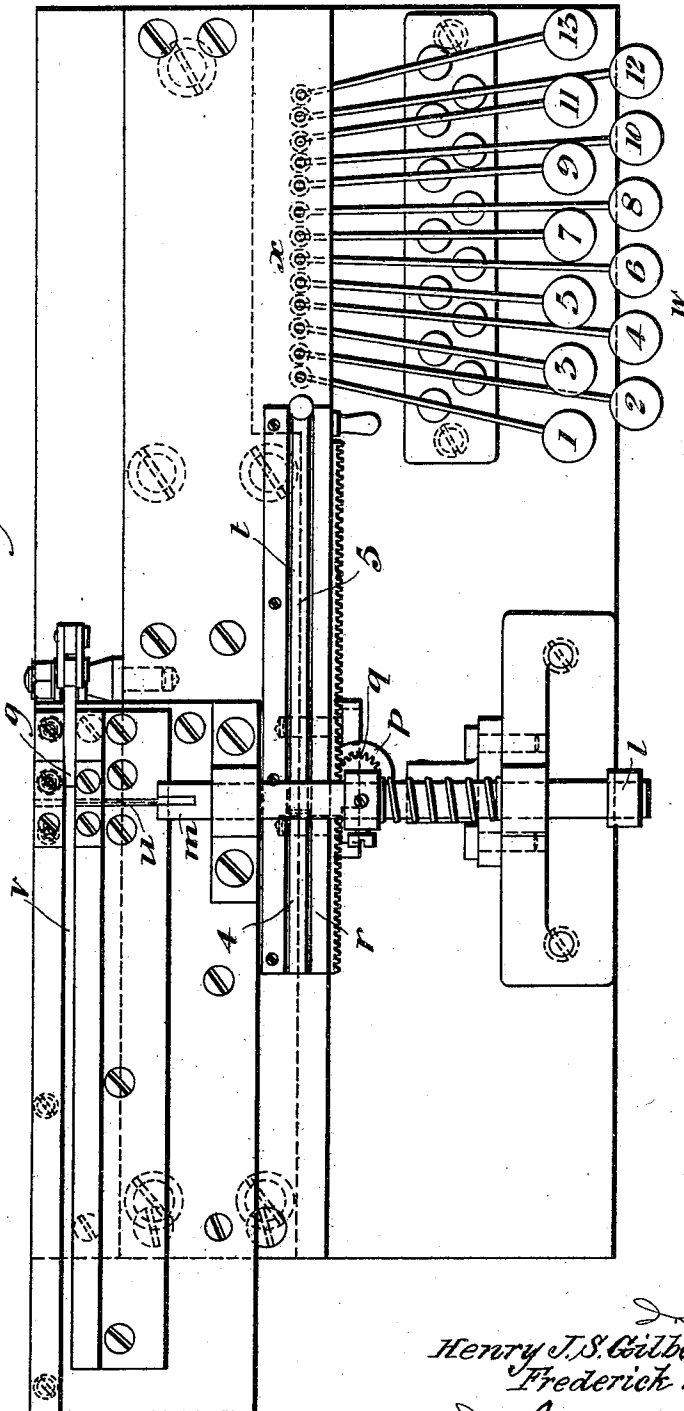

H. J. S. Gilbert-Stringer
F. Wicks
H. C. Kellogg

Inventors
Henry J. S. Gilbert-Stringer
Frederick Wicks.
By James L. Norris
att'y

No. 645,801.

Patented Mar. 20, 1900.

H. J. S. GILBERT-STRINGER & F. WICKS.
APPARATUS FOR JUSTIFYING SET TYPE.

(Application filed Oct. 12, 1899.)

(No Model.)

3 Sheets—Sheet 3.

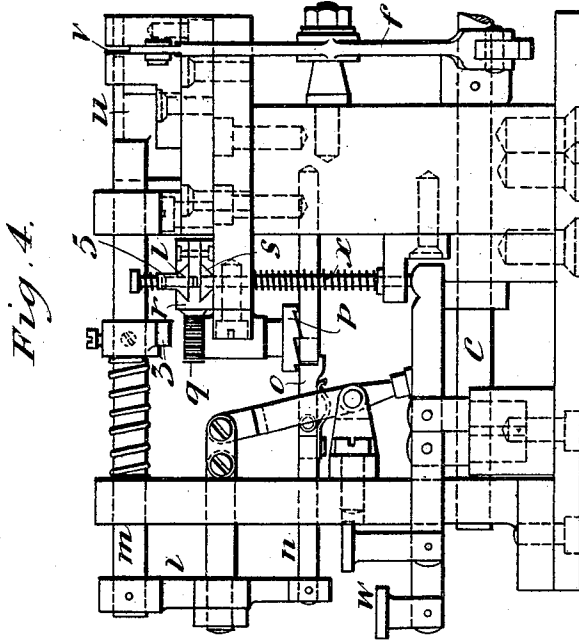

Fig. 4.

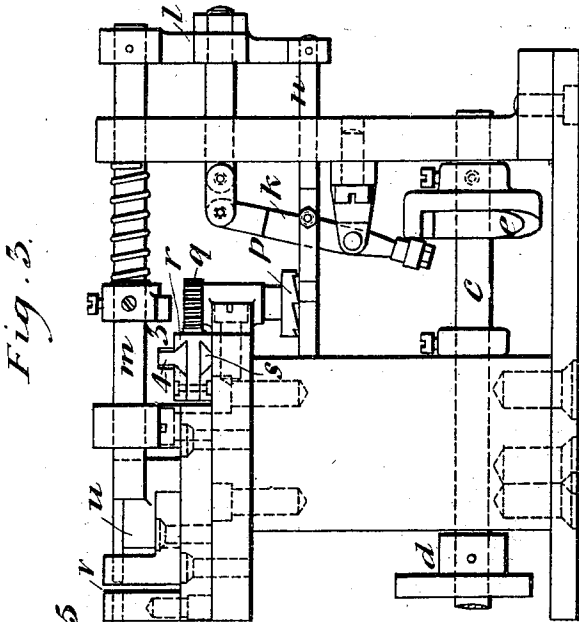

Fig. 5.

Witnesses
J. K. Keedy
W. A. Kellum

Inventors
Henry J. S. Gilbert-Stringer.
Frederick Wicks.
James L. Norris.
att'y

UNITED STATES PATENT OFFICE.

HENRY JAMES SYDNEY GILBERT-STRINGER, OF LONDON, AND FREDERICK WICKS, OF ESHER, ENGLAND.

APPARATUS FOR JUSTIFYING SET TYPE.

SPECIFICATION forming part of Letters Patent No. 645,801, dated March 20, 1900.

Application filed October 12, 1899. Serial No. 733,422. (No model.)

To all whom it may concern:

Be it known that we, HENRY JAMES SYDNEY GILBERT-STRINGER, residing at 35 Tavistock Crescent, Westbourne Park, London; and
5 FREDERICK WICKS, residing at Halfway Lodge, Esher, in the county of Surrey, England, citizens of England, have invented a certain new and useful Apparatus for Justifying Set Types, (for which we have applied
10 for a patent in Great Britain, dated March 15, 1899, No. 5,632,) of which the following is a specification.

This invention relates to simple means of justifying types which are set by composing-
15 machines or otherwise.

Instead of putting in the line of types spaces of different widths or spaces for which others have to be substituted in justifying we employ only spaces of unit thickness or multiples
20 of the unit and never only one space, but always more than one to allow for one or more being ejected in justifying, while still retaining an interval between the words. The line of set types and spaces is forwarded to the justifying mechanism, its length in units and the
25 number of its space groups being indicated in the usual way. The operator, guided by these indications, sets suitable gages, which determine the movements of a pusher reciprocating once for every advance of the type-
30 line. When it meets a type, the pusher is stopped; but when its upper part can pass over the tops of the spaces then if the gage set by the operator does not stop it it pushes
35 out one of the space-types.

Apparatus for operating as described is arranged according to our invention, as we shall describe, referring to the accompanying drawings.

40 Figure 1 is a front view. Fig. 2 is a plan. Figs. 3 and 4 are respectively left and right hand end views. Fig. 5 is a section of the ejecting-blade; and Fig. 6 is a front view of the adjustable slides, shown separately from
45 the rest of the machine.

The machine shown in the drawings is supposed to be placed at the left end of any suitable type-setting machine, within easy reach of the compositor, and it has an upper type-channel
50 *a*, which takes the place of the deliv-

ery-channel usually employed in composing apparatus, surmounted by a space-indicator *b*.

As these parts are of known construction and the space-indicator is worked in the well-
55 known manner from the space-key of the type-setting machine, it is to be understood that no claim is made in respect of those parts *a* and *b*. A spindle *c*, caused to revolve by a
60 hand or otherwise connecting it to a revolving spindle of the setting-machine, has fixed on it an edge-cam *d* and a face-cam *e*. The cam *d*, acting on a roller on a lever *f*, causes that lever to reciprocate, moving a feed-slide
65 *g* and a feed-slide *h*, connected to *f* through a rod *i* and lever *j*. The cam *e*, acting on a roller on a lever *k*, in each revolution moves back—that is to say, to the right in Fig. 3
70 and to the left in Fig. 4—a cross-head *l*, which is urged in the opposite direction by a spring on a sliding rod *m*, attached to the cross-head *l*.
75 Another rod *n*, attached to the cross-head *l*, has pivoted on it a spring-pawl *o*, which when it engages the teeth of a ratchet-wheel *p*, as will hereinafter be described, causes that
80 wheel to turn tooth by tooth, and a pinion *q*, fixed on the axis of *p*, also to turn. This pinion gears with rack-teeth on a slide *r*, which has a projecting rib 4 and is fitted to slide
85 along a fixed V-guide *s*, and in a recess on the upper side of the slide *r* there is another slide *t*, having also a projecting rib 5. From the rear end of the sliding rod *m* projects a
90 blade *u*, the lower part of which is of a thickness somewhat less than that of a unit space-type, while its upper part which projects farther is nearly the thickness of two unit space-
95 types.

A type-channel *v* has a slot cut through its sides for the passage of the blade *u* through
100 it. The blade *u* is of such height that when there is a character-type facing it in the channel *v* the upper projecting part of the blade is stopped by the upper part of the type; but when there are two spaces facing it in the
95 channel the upper part of the blade can pass over the tops of these, which are lower than a character-type, and the lower thin part of the blade can push the second space-type out through the opposite slot. A number of fig-

ured keys w are arranged to act on vertical sliding rods x , which are urged downward by springs. On a horizontal rod y , fixed below the type-channel a , is fitted a slide z , having
 5 an index projecting up from it, pointing to graduations on a gage 1, which can be adjusted to various lengths of line and fixed by screws 2.

The apparatus is operated as follows: The
 10 compositor working the type-setting machine goes on until he sees that the types, (which are delivered into the channel a and are fed forward one by one by the reciprocating feeder h ,) acting on a pin projecting up from
 15 the slide z , have moved that slide to the left until its index is somewhat beyond the zero of the gage 1. He then knows that the composed line is longer than it should be by as many units as indicated on the gage. He
 20 also knows, by looking at the indicator b , that in composing the line the space-key has made a certain number of strokes, or, in other words, that there are in the composed line so many groups of spaces between words, each
 25 group consisting of two space-types of unit thickness. He therefore knows that from this line must be removed as many unit space-types as the number indicated on the gage 1. If these space-types were all removed
 30 from some of the spaces and none from some of the others, the line would be badly justified. If, for instance, the dial shows that there are seven paces in the line and the gage shows that the length of the line is in excess by three units, the operator subtracting three from seven would know that
 35 of the seven groups four would have to be left each with both its units in it, and in order to give uniformity to the line he would determine to leave the two next the ends of
 40 the line untouched and to extract the three units from the three middle spaces. He would therefore depress first the key 3 and pull forward the upper slide t , depressing a spring-button at its end, so as to stop against the
 45 rod x raised by the key 3. Then releasing the button of t and depressing key 2, he would pull forward the lower slide r until it was stopped by the rod of the key 2. The operator
 50 having thus set the slides t and r moves the gage z and the indicator b back to their zero positions and goes on to compose another line. As the types of this line descend and are moved along the channel a by the
 55 pusher h they advance the previous line, for the justification of which he has made preparation. As each character or space type reaches the chute 6 at the left end of the channel a it drops into the channel v in front of
 60 the pusher g , which is reciprocating in unison with the pusher h . The types are thus advanced along the channel v . As the spindle c revolves, causing the cross-head l , and with it the rods m and n , to reciprocate, the forward movement due to the spring on m is
 65 stopped by the upper part of the blade u

meeting character-types in the channel y ; but when the first pair of spaces present themselves the upper part of u can pass over them, the rods m and n making a longer forward
 70 stroke; but they are stopped by a tappet 3, projecting down from the rod m , meeting a rib 4, projecting up from the slide r . The stroke, however, made by the rod n in this case is sufficient to move the wheel p one
 75 tooth around, and thereby to move the slide r a distance equivalent to one of the intervals between the key-rods x . When the next pair of spaces present themselves, the same action takes place, the slide r being thus moved
 80 over another interval of the rods x . As it had in the first place been moved over two intervals to the right and has been moved back two to the left, the end of the rib 4 is now in such a position that it is clear of the
 85 tappet 3, and therefore when the next pair of spaces present themselves to the blade u the rod m makes its full stroke, the lower part of the blade u ejecting the right-hand unit of the space. This is repeated when the
 90 next two pairs of spaces present themselves; but then the upper slide t , having moved with the lower slide through the three intervals at which it had been set, has been brought to such a position that its projecting rib 5 forms
 95 a stop to the tappet 3 in the same way as the rib of the lower slide, and consequently when the next two pairs of spaces present themselves there is no ejection of their units.

In other cases where the number of spaces
 100 and units of excess length in the line vary the operator has to exercise his judgment as to which spaces he should select for ejection.

If, for instance, there were five spaces and two units of excess length, he might eject
 105 from the second and third or from the third and fourth spaces. In this case he would stop the upper slide t by the rod or key 2, thus determining that two spaces have to undergo ejection, and he would stop the slide r
 110 by the rod of key 1, in which case the second and third spaces would be reduced, or he would stop it by the rod of key 2, in which case the third and fourth spaces would be reduced.

Having thus described the nature of this
 115 invention and the best means we know of carrying the same into practical effect, we claim—

In combination with a type-setting machine
 120 and its indicators showing numbers of spaces and length of lines, a justifying apparatus comprising a set of finger-keys and spring stop-pins for a rack-slide with upwardly-projecting rib and for a second slide with rib, carried on the rack-slide, a shaft carrying a cam for working a pair of feeders in type-channels,
 125 and a cam causing a cross-head and spring-rod to reciprocate, the said rod having a blade adapted to pass through a slot of a type-channel and extrude space-types, and a tappet to
 130 meet the ribs of the slides, the said cross-

head having connected to it a spring-pawl
engaging with teeth of a ratchet-wheel, on
the shaft of which is a pinion engaging the
teeth of the rack-slide, constructed and oper-
5 ating substantially as and for the purpose
set forth.

In testimony whereof we have hereunto set

our hands in presence of two subscribing wit-
nesses.

HENRY JAMES SYDNEY GILBERT-STRINGER,
FREDERICK WICKS.

Witnesses:

GERALD L. SMITH,
EDWARD GARDNER.