

12

EUROPEAN PATENT SPECIFICATION

45 Date of publication of patent specification: **20.03.85**

51 Int. Cl.⁴: **E 02 B 17/02**

21 Application number: **81201329.0**

22 Date of filing: **04.12.81**

54 **Artificial island.**

30 Priority: **09.12.80 NL 8006679**

43 Date of publication of application:
16.06.82 Bulletin 82/24

46 Publication of the grant of the patent:
20.03.85 Bulletin 85/12

84 Designated Contracting States:
GB NL

50 References cited:
GB-A-1 220 689
NL-A-7 201 658
US-A-2 210 408
US-A-3 367 119
US-A-3 402 557
US-A-3 727 414

73 Proprietor: **GUSTO ENGINEERING B.V.**
's-Gravelandseweg 557 P.O.Box 11
NL-3100 AA Schiedam (NL)

72 Inventor: **Boon, Bart**
Bernard Zweersplein 66
NL-3122 TW Schiedam (NL)

7A Representative: **van der Beek, George Frans**
et al
Nederlandsch Octrooibureau Johan de Wittlaan
15 P.O. Box 29720
NL-2502 LS 's-Gravenhage (NL)

EP 0 053 861 B1

Note: Within nine months from the publication of the mention of the grant of the European patent, any person may give notice to the European Patent Office of opposition to the European patent granted. Notice of opposition shall be filed in a written reasoned statement. It shall not be deemed to have been filed until the opposition fee has been paid. (Art. 99(1) European patent convention).

Description

The invention relates to an artificial island comprising a platform, such as a pontoon and at least three legs for placing the island on the sea bottom and for supporting the platform, said platform and legs being provided with means for moving the legs and platform with respect to each other in vertical direction and for locking the platform on the legs, said legs being rigidly interconnected at a common level between the outer ends of the legs by means of a frame structure, said legs and frame structure being located outside the perimeter of the platform.

An artificial island of this type is known from US—A 3 402 557. In said known artificial island pontoon and legs are free to move with respect to each other in a vertical direction due to the fact that the legs together with the interconnecting frame structure, lie completely outside the perimeter of the pontoon. In said known structure the legs are not only interconnected by a rigid frame structure halfway the height of the legs but also by a similar rigid frame structure near the top of the legs and close to the lower ends. This means that the legs and interconnecting frame structures form a heavy unit. This unit can be moved to the place of destination by making use of the buoyancy of the pontoon whereafter the entire supporting structure formed by all the legs and interconnecting frame structures can be lowered by using the jacking mechanism. When the supporting structure is placed the pontoon can be moved upwards along the legs up to a level out of reach of the waves.

During lowering of the supporting structure the pontoon, however, is subjected to the movements of the waves. This means that any movement of the pontoon about the horizontal axis results in a swinging movement of the supporting structure. When the lower end of the supporting structure comes close to the sea bottom this means that the pontoon carries a heavy pendulum swinging over the bottom which pendulum at further lowering of the structure will hit the bottom. This means the sudden occurrence of heavy loads must be taken up by the frame structure without disturbing the connection between the pontoon and the legs. For this purpose the pontoon is guided upon the legs such that the bending moments, which at the connection with the pontoon have a high value, can be taken up.

Purpose of the invention is to provide an artificial island having a light construction, which island is better suited for great water depths and/or heavy weather conditions and yet is simple of construction.

According to the invention said object is achieved in that the supporting joints between each leg and the platform is a pivot joint and at least the leg sections below the rigid frame structure are only interconnected by a cross configuration of cables or ties located outside the perimeter of the platform. This means that the connection between the platform or pontoon and

each leg, although made such that leg and platform cannot move apart, does not take up any moment and that the supporting structure preferably is only formed by the legs and the interconnecting rigid structure at half height of the legs, the taking up of moments being performed by the crosswise extending cables or the like extending in planes outside the perimeter of the platform. Said cables form a light construction whereas the connection between platform and legs also allows a light construction. The result is a supporting structure which during lowering is not a heavy but a light pendulum; which surprisingly can be handled well during the dynamic situation occurring during lowering the supporting structure or raising respectively and which in the stationary operative position is capable of taking up occurring loads from wind and waves and from the operations for which the island has been designed.

It is observed that from published NL—A 7 201 658 an artificial island is known comprising the combination of a supporting frame structure standing upon a pontoon and a buoyant platform. Both components are prefabricated and floated towards the destination where the supporting structure is lowered upon the sea bottom by adding ballast, is embedded in the sea bottom and filled with concrete to obtain a non-removable supporting structure. The lowering of such a structure is different from the lowering of a structure suspended from a pontoon because the pontoon is ballasted and does not act as a pendulum.

The platform is separately floated to the already placed supporting structure and lifted out of the water by means of hoisting devices provided temporarily after which the platform is provided with laterally extending supports or arms which rest upon the supporting structure by means of bearings which act as a pivot point. Due to this way of supporting the platform no moments are transferred towards the supporting structure. The support is the same as usual for supporting a bridge. This manner of supporting the platform is not able to take up horizontal forces or with other words it is not a joint.

By the combination of rigidly connected horizontal beams and the cross-configuration of the tie beams or cables in the island of the invention, a light construction can be realized. Preferably the horizontal beams are thereby located at the half height of said legs.

According to the invention it is possible to connect the legs over their whole length to each other. If these connections are hindering the accessibility, e.g. the supply of material, then the connections positioned above the horizontal beams can be embodied removable. Such removable cable connection can also be useful to couple the upper ends of said legs together when said legs are in the raised position.

The invention makes it possible to alter the horizontal cross-section of each leg in the height or longitudinal direction of said leg. Said cross-

section can be adapted to the acting momental load such that the cross-section narrows from the horizontal beams to the ends of the legs. It is also possible to enlarge the cross-section of the part underneath said beams to get an increased standing surface and therewith an increased stability. These possibilities to vary the cross sectional shape, which are only mentioned as examples, are offered because of the pivot joint support of the platform and because the platform is able to move freely in vertical direction through the supporting construction formed by the legs and the connecting means without obstructing said freedom of movement by parts of the supporting construction.

Because the legs are coupled to each other into a rigid configuration it is not possible as by the known islands to adapt said legs independent of each other in vertical direction and also adaptations to bottom irregularities are not simply possible anymore. One of the measures to avoid inclination and to make adaptations possible is to provide the legs with extendible and retractable jacks or auxiliary legs. These means are individually known from the prior art, just as the possibility to provide the under side of the legs with displacing means, such as endless-track units.

It is remarked that in "Ocean Industry", September 1973, page 115, an artificial island is described comprising a supporting frame with in vertical direction in relation thereto displaceable supporting legs and rigidly thereto connected upwards directed columns for moving the pontoon there along and arresting said pontoon. In this known construction the moments resulting from horizontal loads are transferred through the columns and the legs with the thereto coupled supporting frame and have a value which is approximately half the value generated in islands having throughgoing columns whereby the coupling between the legs and the pontoon is realized by means of leg guiding elements onto said pontoon. The necessity to use guiding elements for said legs which are able to receive said moments, however, still consists and the supporting frame carrying said columns therefore is still a heavy construction.

Furthermore known is the "Transworld Rig 60" built by Mitsui Shipbuilding & Engineering Co., Ltd., comprising four vertical buoyancy bodies which are coupled to each other by means of a framework of tubes from which four tubular columns are reaching upwards along which the platform can be moved upwards or downwards. Also in this rig the bending moments in the columns are reduced, but the platform can only move downwards until the upper level of the framework coupled to the buoyancy bodies, so that one has a top heavy construction during transport.

The invention will now be explained in more detail with reference to the drawings.

Fig. 1 illustrates a side view of an embodiment of an artificial island according to the invention;

Fig. 2 illustrates another view of the island shown in Fig. 1;

Fig. 3 illustrates schematically another embodiment; and

Fig. 4 illustrates a further embodiment.

The island illustrated in Fig. 1 comprises three legs 1, 2 and 3 contained into a framework. Between said legs the platform 4, embodied as a pontoon, is supported by not in detail illustrated couplings 5, 6, 7 respectively, embodied as pivot joint supports for supporting the legs 1, 2 and 3 and in the upstanding sections 8 and 9 thereof a jacking and latching mechanism, which is also not illustrated in detail is housed. Such mechanism can be realized by jacking and latching cylinders cooperating with latching beams and working with gear racks or toothed sections or other known means.

Onto this platform several devices can be installed such as a drilling derrick 10, a crane 11 etc.

According to the invention the legs 1 to 3 are coupled into a stiff configuration by means of the horizontal beams 12, 13 and 14 which, as is the best illustrated in Fig. 2, extend such that they are positioned outside the vertical bounding surface of the perimeter of the pontoon 4 and by means of cross-configured tie beams or cables 15 and 16.

The legs 1 to 3 have extendible leg portions 17 at their bottom ends to make adaptations for instance to an inclined sea bottom possible.

The embodiment of Fig. 3 differs from that illustrated in Fig. 1 in fact only in that the legs have a cross-sectional shape with a maximum dimension at the height of the horizontal beams 12 and a cross-sectional dimension which is narrowing in the upwards and downwards leg direction as adaption of the necessary material to the generated maximal momental load.

In the embodiment of Fig. 4 the legs 1 and 2, which are rigidly coupled by the beams 12 and the cross-configurations 15, 16, are enlarged by the sideways extending broadenings 18 and 19 such that an increased carrying surface is realized.

Fig. 4 also indicates that it is possible to install one or more cross-configurations 20, 21 and/or horizontal tie cables 22 in the section above the horizontal beam 12.

Claims

1. Artificial island comprising a platform (4), such as pontoon and at least three legs (1, 2, 3) for placing the island on the sea bottom and for supporting the platform (4), said platform (4) and legs (1, 2, 3) being provided with means (8, 9) for moving the legs (1, 2, 3) and platform (4) with respect to each other in vertical direction and for locking the platform (4) on the legs (1, 2, 3), said legs (1, 2, 3) being rigidly interconnected at a common level between the outer ends of the legs by means of a frame structure (12, 13, 14), said legs (1, 2, 3) and frame structure (12, 13, 14) being located outside the perimeter of the platform (4), characterized in that the supporting joint (5, 6, 7)

5

10

15

20

25

30

35

40

45

50

55

60

65

3

between each leg (1, 2, 3) and the platform (4) is a pivot joint and at least the leg sections below the rigid frame structure (12, 13, 14) are only interconnected by a cross configuration of cables or ties (15, 16) located outside the perimeter of the platform.

2. Artificial island as claimed in claim 1, characterized in that the legs (1, 2, 3) above the rigid frame structure (12, 13, 14) are interconnected by disconnectable cables (20, 21, 22).

3. Artificial island as claimed in claim 1 or 2, characterized in that the horizontal cross sectional shape of each of said legs (1, 2, 3) changes in the height or longitudinal direction.

4. Artificial island as claimed in claim 3, characterized in that the cross section has a maximum at the level of the horizontal interconnecting rigid structure (12, 13, 14) and decreases towards the ends of the legs (1, 2, 3).

5. Artificial island as claimed in claim 3, characterized in that the cross section enlarges in downwards direction in the section (1) underneath the rigid structure (12, 13, 14).

Revendications

1. Ile artificielle, comprenant une plate-forme (4), telle que ponton, et au moins trois pieds (1, 2, 3) pour placer l'île sur le sol marin et pour porter la plate-forme (4), la dite plate-forme (4) et les pieds (1, 2, 3) étant équipés de moyens (8, 9) pour déplacer les pieds (1, 2, 3) et la plate-forme (4) par rapport l'un à l'autre dans le sens vertical et pour verrouiller la plate-forme (4) sur les pieds, les dits pieds (1, 2, 3) étant rigidement reliés l'un à l'autre à une hauteur commune entre les extrémités extérieures des pieds au moyen d'un cadre (12, 13, 14), les dits pieds (1, 2, 3) et le cadre (12, 13, 14), étant logés à l'extérieur du périmètre de la plate-forme (4), caractérisée en ce que le joint de support (5, 6, 7) entre chaque pied (1, 2, 3) et la plate-forme (4) est un joint à pivot, et au moins les sections des pieds au-dessous du cadre rigide (12, 13, 14) ne sont interconnectées que par une configuration croisée de câbles ou de tirants (15, 16) situés à l'extérieur du périmètre de la plate-forme.

2. Ile artificielle selon la revendication 1, caractérisée en ce que les pieds (1, 2, 3) au-dessus du cadre rigide (12, 13, 14) sont reliés entre eux par des câbles amovibles (20, 21, 22).

3. Ile artificielle selon la revendication 1 ou 2, caractérisée en ce que la forme de la section horizontale de chaque pied (1, 2, 3) change selon la direction en hauteur ou horizontale.

4. Ile artificielle selon la revendication 3, caractérisée en ce que la section transversale est maximum à la hauteur de la structure rigide d'interconnection horizontale (12, 13, 14) et décroît vers les bouts des pieds (1, 2, 3).

5. Ile artificielle selon la revendication 3, caractérisée en ce que la section transversale s'accroît vers le bas dans la partie (1) au-dessous de la structure rigide (12, 13, 14).

Patentansprüche

1. Künstliche Insel mit einer Plattform (4) wie Ponton oder dergleichen und mindestens drei Beinen (1, 2, 3) zum Aufstellen der Insel auf dem Meeresgrund und zum Tragen der Plattform (4), wobei diese Plattform (4) und die Beine (1, 2, 3) mit Mitteln (8, 9) zur Bewegung der Beine (1, 2, 3) und der Plattform (4) gegeneinander in senkrechter Richtung und zum Verriegeln der Plattform (4) an den Beinen (1, 2, 3) versehen sind, und wobei die Beine (1, 2, 3) auf einer gemeinsamen Höhenlinie zwischen den äusseren Enden der Beine mittels einer Rahmenstruktur (12, 13, 14) starr miteinander verbunden sind, und wobei die genannten Beine (1, 2, 3) und die Rahmenstruktur (12, 13, 14) ausserhalb des Umfanges der Plattform (4) liegen, dadurch gekennzeichnet, dass die tragende Verbindung (5, 6, 7) zwischen jedem der Beine (1, 2, 3) und der Plattform (4) eine Gelenkverbindung ist und mindestens diejenigen Abschnitte der Beine, die unterhalb der starren Rahmenstruktur (12, 13, 14) liegen, lediglich kreuzförmig durch Kabel oder Zugstangen (15, 16) miteinander verbunden sind, welche ausserhalb des Umfanges der Plattform liegen.

2. Künstliche Insel nach Anspruch 1, dadurch gekennzeichnet, dass die Beine (1, 2, 3) oberhalb der starren Rahmenstruktur (12, 13, 14) durch abnehmbare Kabel (20, 21, 22) miteinander verbunden sind.

3. Künstliche Insel nach Anspruch 1 oder 2, dadurch gekennzeichnet, dass die Form des horizontalen Querschnittes jedes Beins (1, 2, 3) sich mit der Höhe oder in Längsrichtung ändert.

4. Künstliche Insel nach Anspruch 3, dadurch gekennzeichnet, dass der Querschnitt in der Höhe der starren horizontalen Verbindungsstruktur (12, 13, 14) am grössten ist und gegen die Enden der Beine (1, 2, 3) abnimmt.

5. Künstliche Insel nach Anspruch 3, dadurch gekennzeichnet, dass sich der Querschnitt nach unten im Bereich (1) unterhalb der starren Struktur (12, 13, 14) vergrössert.

fig-1

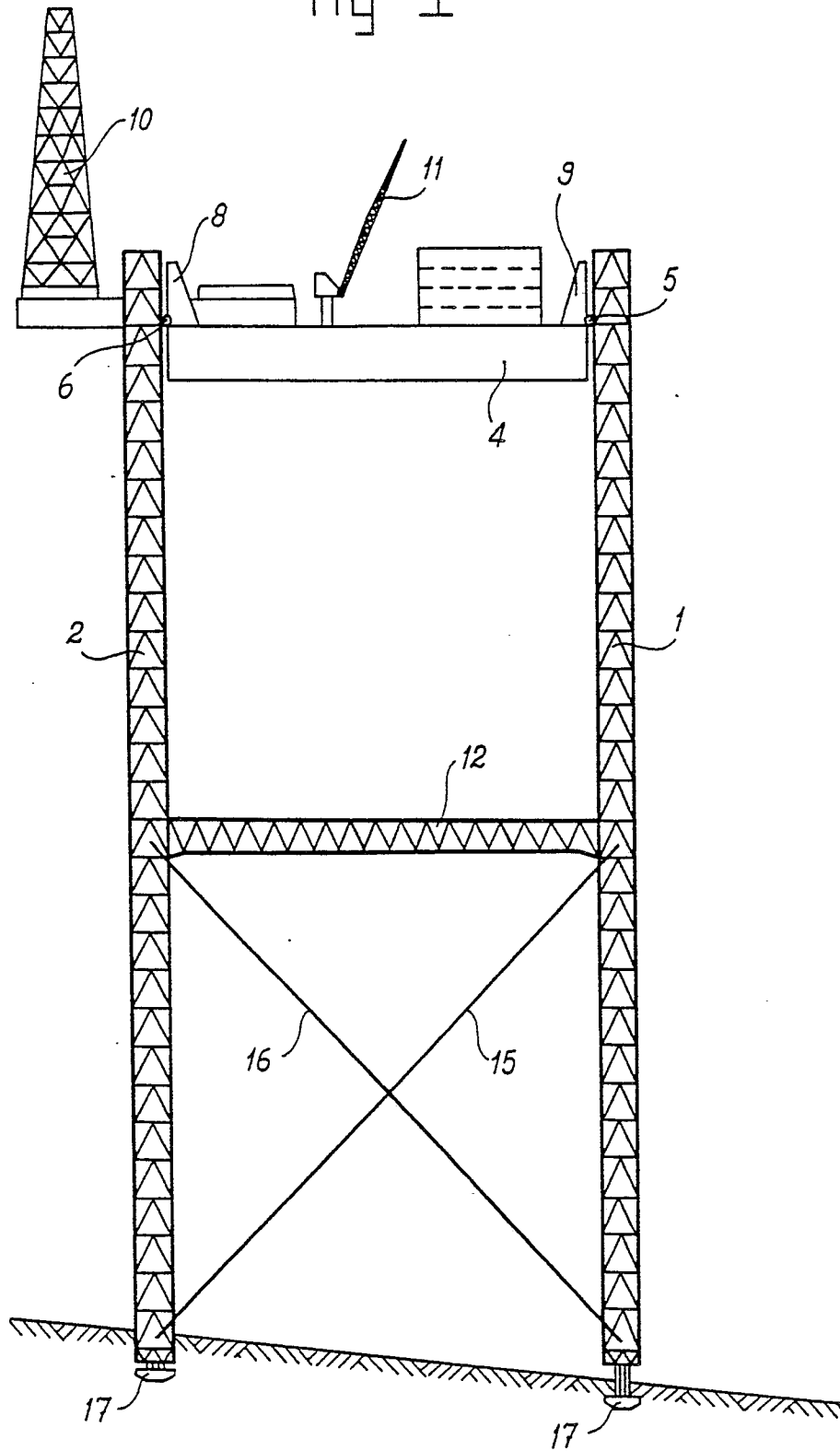

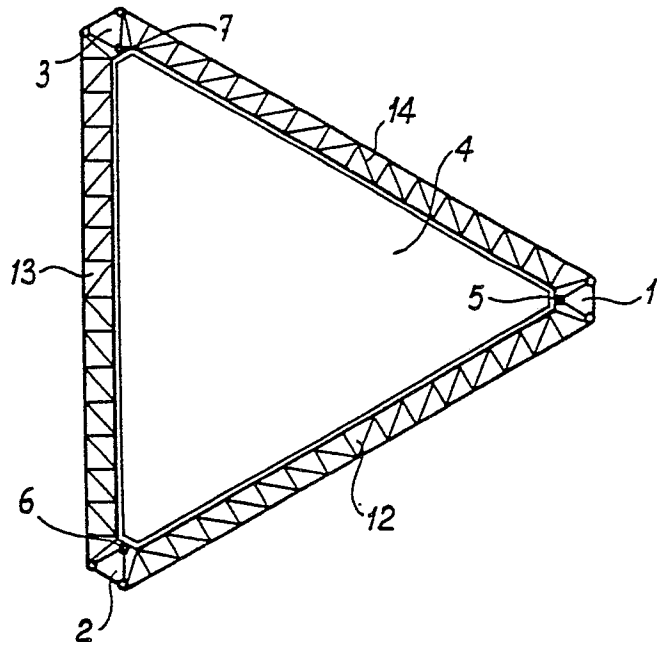

fig-2

fig-3

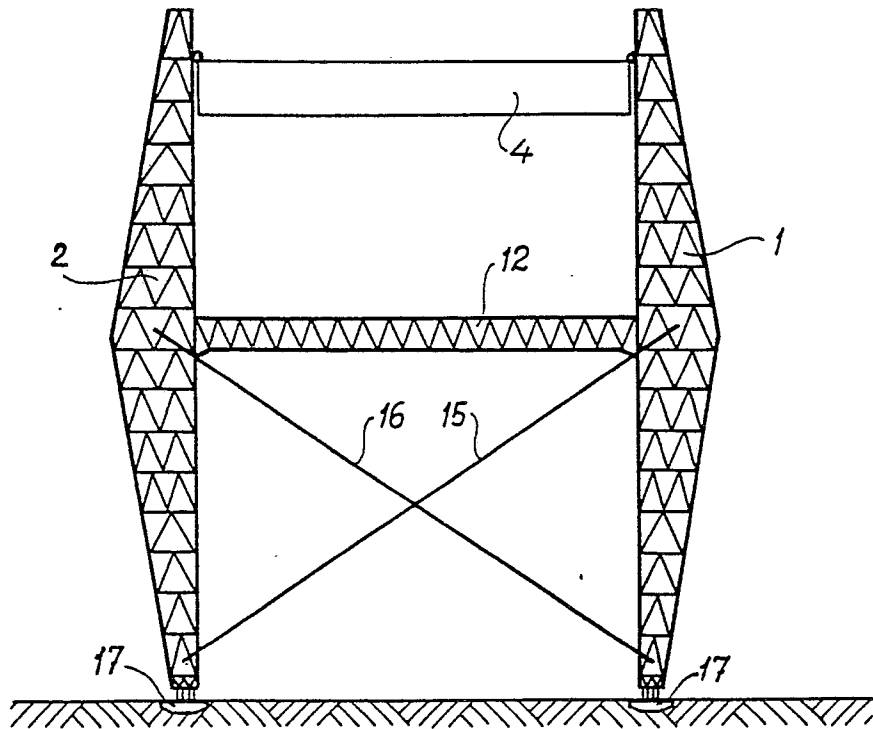

fig-4

